

Earth-moving machinery — Operator enclosure environment

Part 2: Air filter element test method

ICS 53.100

National foreword

This British Standard is the UK implementation of ISO 10263-2:2009. It supersedes BS 6912-22.2:1996 which is withdrawn.

The UK participation in its preparation was entrusted to Technical Committee B/513/1, Earth moving machinery (International).

A list of organizations represented on this committee can be obtained on request to its secretary.

This publication does not purport to include all the necessary provisions of a contract. Users are responsible for its correct application.

Compliance with a British Standard cannot confer immunity from legal obligations.

This British Standard was published under the authority of the Standards Policy and Strategy Committee on 30 April 2009

© BSI 2009

ISBN 978 0 580 57406 1

Amendments/corrigenda issued since publication

Date	Comments

**Earth-moving machinery — Operator
enclosure environment —**

Part 2:
Air filter element test method

*Engins de terrassement — Environnement de l'enceinte de
l'opérateur —*

Partie 2: Méthode d'essai de l'élément du filtre à air



PDF disclaimer

This PDF file may contain embedded typefaces. In accordance with Adobe's licensing policy, this file may be printed or viewed but shall not be edited unless the typefaces which are embedded are licensed to and installed on the computer performing the editing. In downloading this file, parties accept therein the responsibility of not infringing Adobe's licensing policy. The ISO Central Secretariat accepts no liability in this area.

Adobe is a trademark of Adobe Systems Incorporated.

Details of the software products used to create this PDF file can be found in the General Info relative to the file; the PDF-creation parameters were optimized for printing. Every care has been taken to ensure that the file is suitable for use by ISO member bodies. In the unlikely event that a problem relating to it is found, please inform the Central Secretariat at the address given below.



COPYRIGHT PROTECTED DOCUMENT

© ISO 2009

All rights reserved. Unless otherwise specified, no part of this publication may be reproduced or utilized in any form or by any means, electronic or mechanical, including photocopying and microfilm, without permission in writing from either ISO at the address below or ISO's member body in the country of the requester.

ISO copyright office
Case postale 56 • CH-1211 Geneva 20
Tel. + 41 22 749 01 11
Fax + 41 22 749 09 47
E-mail copyright@iso.org
Web www.iso.org

Published in Switzerland

Contents

Page

Foreword	iv
1 Scope	1
2 Normative references	1
3 Terms and definitions	1
4 Air filter element performance test	1
5 Test report	3
Annex A (informative) Example of test report form for panel-type filter	7
Annex B (informative) Alternate method for air filter element performance evaluation	8
Bibliography	10

Foreword

ISO (the International Organization for Standardization) is a worldwide federation of national standards bodies (ISO member bodies). The work of preparing International Standards is normally carried out through ISO technical committees. Each member body interested in a subject for which a technical committee has been established has the right to be represented on that committee. International organizations, governmental and non-governmental, in liaison with ISO, also take part in the work. ISO collaborates closely with the International Electrotechnical Commission (IEC) on all matters of electrotechnical standardization.

International Standards are drafted in accordance with the rules given in the ISO/IEC Directives, Part 2.

The main task of technical committees is to prepare International Standards. Draft International Standards adopted by the technical committees are circulated to the member bodies for voting. Publication as an International Standard requires approval by at least 75 % of the member bodies casting a vote.

Attention is drawn to the possibility that some of the elements of this document may be the subject of patent rights. ISO shall not be held responsible for identifying any or all such patent rights.

ISO 10263-2 was prepared by Technical Committee ISO/TC 127, *Earth-moving machinery*, Subcommittee SC 2, *Safety, ergonomics and general requirements*.

This second edition cancels and replaces the first edition (ISO 10263-2:1994), which has been technically revised.

ISO 10263 consists of the following parts, under the general title *Earth-moving machinery — Operator enclosure environment*:

- *Part 1: Terms and definitions*
- *Part 2: Air filter element test method*
- *Part 3: Pressurization test method*
- *Part 4: Heating, ventilating and air conditioning (HVAC) test method and performance*
- *Part 5: Windscreen defrosting system test method*
- *Part 6: Determination of effect of solar heating*

Earth-moving machinery — Operator enclosure environment —

Part 2: Air filter element test method

1 Scope

This part of ISO 10263 specifies a uniform test method to determine performance levels of operator enclosure panel-type air filters used to filter the air entering an earth-moving machine operator enclosure with a powered fresh air system.

2 Normative references

The following referenced documents are indispensable for the application of this document. For dated references, only the edition cited applies. For undated references, the latest edition of the referenced document (including any amendments) applies.

ISO 5011:2000, *Inlet air cleaning equipment for internal combustion engines and compressors — Performance testing*

ISO 10263-1, *Earth-moving machinery — Operator enclosure environment — Part 1: Terms and definitions*

ISO 12103-1, *Road vehicles — Test dust for filter evaluation — Part 1: Arizona test dust*

3 Terms and definitions

For the purposes of this document, the terms and definitions given in ISO 10263-1 and the following apply.

3.1

filter efficiency

measure of the ability of the air filter element to remove particulate matter

3.2

operator enclosure air filter element

medium in which particulate matter is removed from the incoming air supply

3.3

test dust

particulate matter used to evaluate the filter element

4 Air filter element performance test

The test shroud configurations for the operator enclosure filter comparison tests are given in 4.1.1 and Figure 1. This test procedure also designates a recommended intake velocity for the dust-mixing chamber.

4.1 Test equipment and instruments

4.1.1 Test equipment

Test equipment in accordance with Figure 2, used to determine the resistance to air flow, particulate holding capacity, particulate removal efficiency, and sealing characteristics. For element configurations other than panel type, see ISO 5011.

4.1.2 Dust metering device

Dust metering device used in accordance with Figure 3 and the dust injector in Figure 4 is capable of metering dust over the range of delivery rates required. This dust feed system shall not change the primary particle size distribution of the particulate. The average delivery rate shall be within 5 % of the desired rate and the deviation in the instantaneous delivery rate from the average shall be no more than 5 %.

4.2 Test conditions and material

4.2.1 All air flow measurements are to be corrected to a standard condition of 25 °C at 100 kPa.

4.2.2 Test dust shall be standardized and shall be of two grades labelled ISO 12103-A2 (fine) and ISO 12103-A4 (coarse). For typical particle size distribution and chemical composition, refer to ISO 12103-1.

It is difficult to select a test dust size distribution and concentration which will be representative of all service conditions, therefore based primarily on practical considerations, the concentration shall be 1 g/m³ for A2 and A4 dusts (1 g/m³ is generally accepted as zero visibility conditions).

4.2.3 The absolute filter shall consist of fibreglass medium with a minimum thickness of 12,7 mm and a minimum density of 9,5 kg/m³. The fibre diameter shall be 0,76 µm to 1,27 µm and the moisture absorption shall be less than 1 % by weight after exposure to 50 °C and 95 % relative humidity for 96 h. The filter shall be installed with the nap side facing upstream in an airtight holder that adequately supports the medium. The face velocity shall not exceed 50 m/min to maintain medium integrity.

4.2.4 The mass of the absolute filter shall be measured to the nearest 0,01 g after the weight has stabilized and while in a ventilation oven at (105 ± 5) °C.

4.2.5 All tests shall be conducted with air entering the air filter at a temperature of (24 ± 8) °C and a relative humidity of (50 ± 15) %.

NOTE Since atmospheric conditions affect test results, when comparing performance of filters designed for the same application, tests are conducted within the narrowest range of temperature and humidity possible.

4.2.6 The velocity of the air entering the top of the dust mixing chamber shall be a minimum of 6 m/s. See Figure 1.

4.2.7 Air flow restriction and pressure drop tests shall be conducted using a minimum of three points: 80 %, 100 % and 120 % of rated air flow using the element restriction test setup shown in Figure 2. Condition the unit to be tested for at least 30 min under temperature and humidity conditions equivalent to those of the test area.

4.2.8 The air filter efficiency, E , as a percentage, is calculated as given in Equation (1):

$$E = \frac{\Delta m_t}{\Delta m_t + \Delta m_A} \times 100 \quad (1)$$

where

Δm_t is the increase in mass of the filter element under test;

Δm_A is the increase in mass of the absolute filter.

The alternative efficiency method is given in Annex B.

5 Test report

A sample test report form for panel-type air filters is given in Annex A.

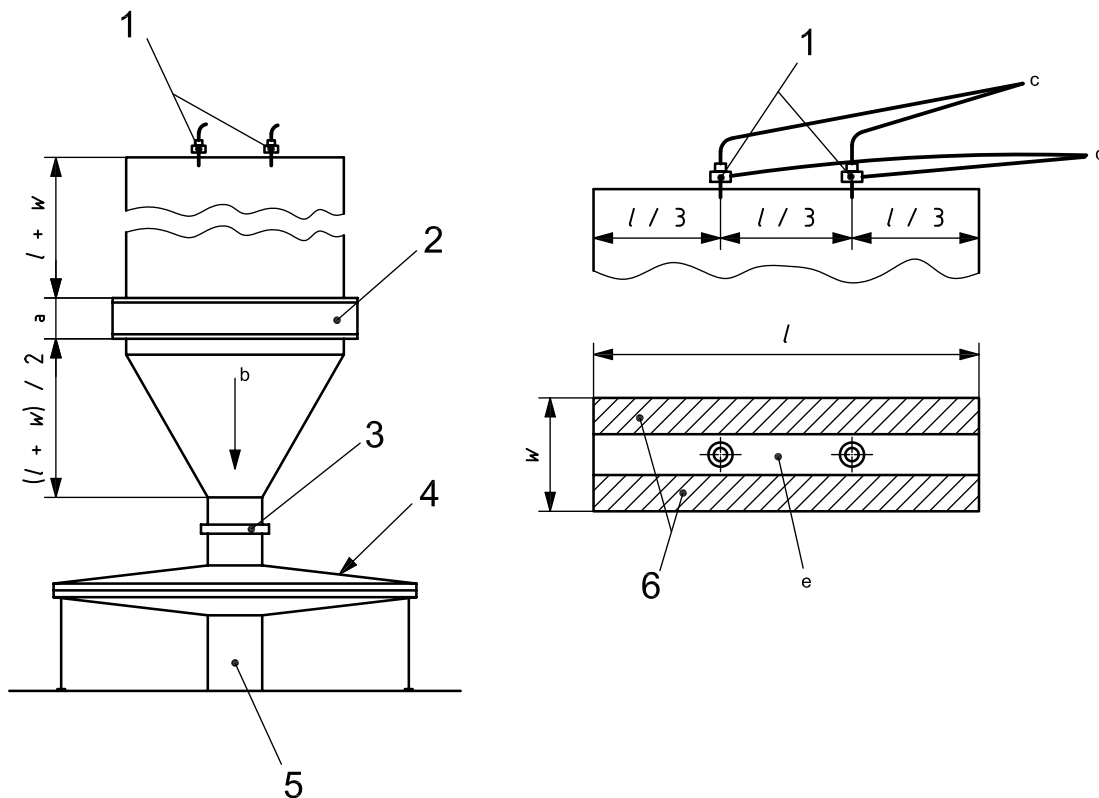

Key

- 1 dust injectors
 - 2 filter element being tested
 - 3 piezometer ring
 - 4 absolute filter housing
 - 5 blower
 - 6 restrictor plates
- a Filter depth.
 - b Flow.
 - c Compressed air.
 - d From dust feeder.
 - e Velocity calculated between top restrictor plates.

Figure 1 — Test shroud

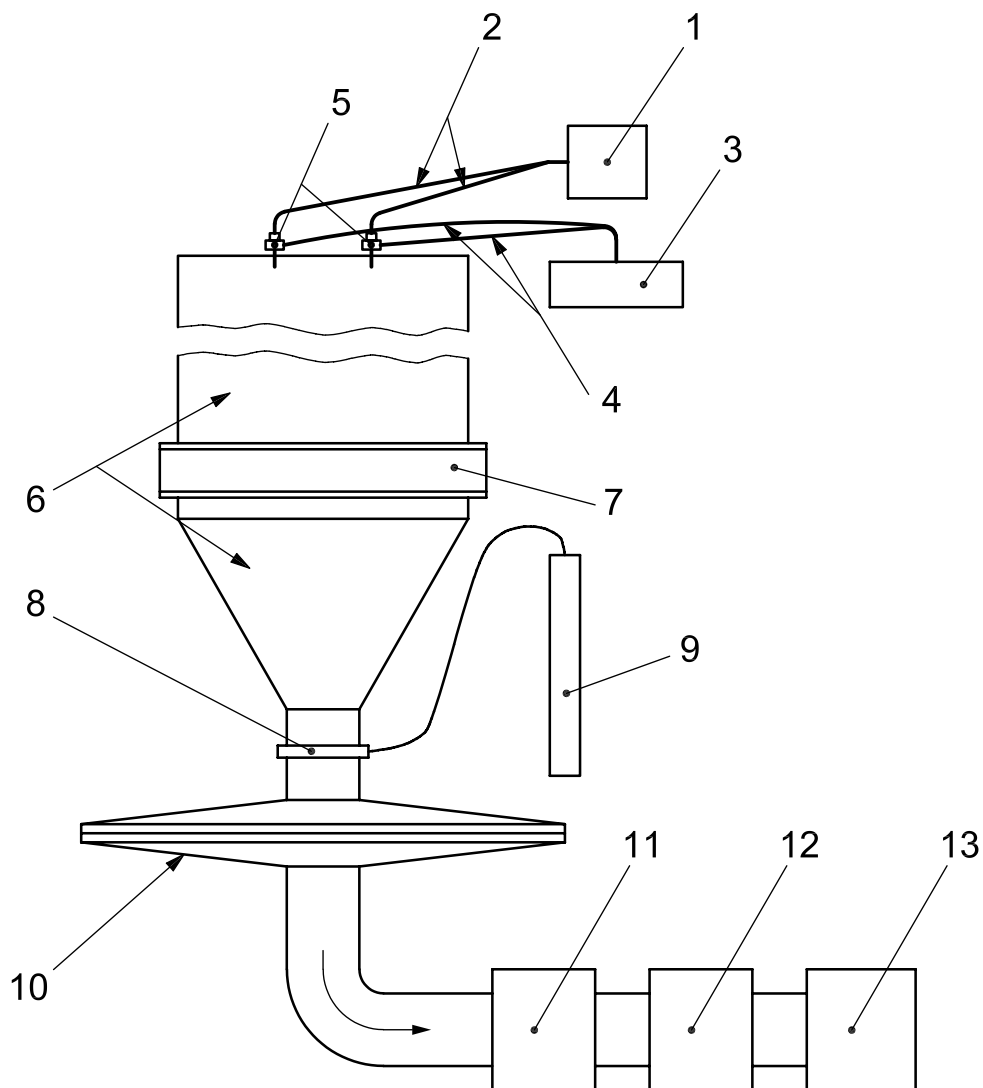

Key

- 1 compressed air supply
- 2 compressed air lines
- 3 dust metering device
- 4 dust transfer tubing
- 5 dust injectors
- 6 test shroud
- 7 filter element being tested
- 8 piezometer ring
- 9 restriction measuring device
- 10 absolute filter housing
- 11 flow rate measuring device
- 12 flow rate control system
- 13 blower or other device for inducing air flow

Figure 2 — Test equipment setup

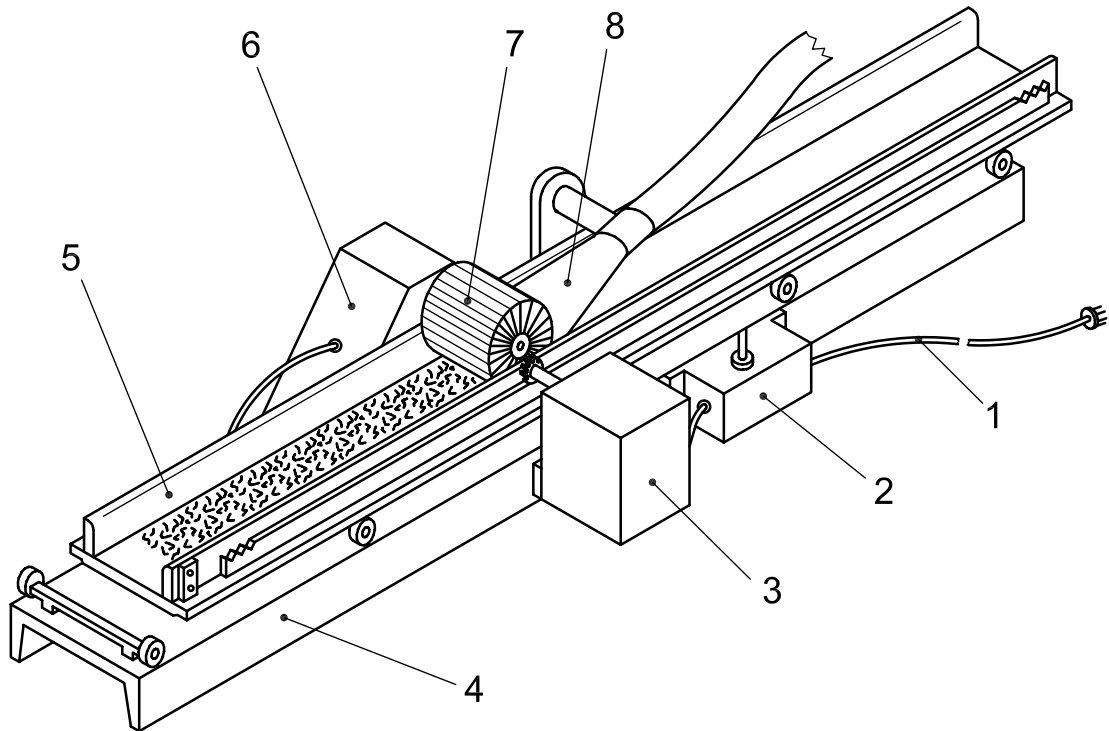

Key

- 1 power cord
- 2 control box
- 3 tray drive motor
- 4 guide base
- 5 dust tray
- 6 brush drive motor
- 7 feeder brush
- 8 aspirator manifold

Figure 3 — Dust feeder

Annex A
(informative)

Example of test report form for panel-type filter

Test flow rate:..... m³/min
Initial restriction: Pa
Dust concentration (4.2.2 and ISO 10263-4:2008, 6.1.4): g/m³
Dust type: A2/A4
Minimum quantity of dust to obtain a restriction of Pa: g
Minimum efficiency of filter element at above restriction:..... %
Minimum efficiency of filter element for a restriction of 125 Pa, initial efficiency:..... %

Laboratory test conditions

	Before	After
Temperature °C °C
Relative humidity % %
Barometric pressure kPa kPa

Annex B (informative)

Alternate method for air filter element performance evaluation

B.1 General

The efficiency calculation method shown from B.2.2.1 to B.2.2.5 corresponds to ISO 5011:2000, 7.5.2.11 to 7.5.2.15. This method can produce efficiency results that are erroneously high unless procedures cited in B.2.2.1 and B.2.2.2 are strictly followed. Weighing the complete unit as prescribed in B.2.2.3 can induce filter element efficiency calculation errors as dust in the ducting and test chamber becomes included in the filter element efficiency calculation and is not part of the filter element. The statement in B.2.2.2 that dust removed from the exterior surfaces/ducting/test chambers should be transferred to the original dust container is erroneous. This is not an acceptable practice. During a test, large particles can become separated from the flow stream and settle in the duct. Returning them to the original dust container will change the dust distribution of that test dust sample and render it invalid. All dust from the exterior surfaces, ducting, and test chambers is to be discarded.

B.2 Test procedure for alternate filter efficiency method

B.2.1 The alternate filter efficiency calculation method as defined in ISO 5011:2000, 7.5.2, may be used provided the test practices prescribed in B.1 are followed.

B.2.2 The following clauses of ISO 5011:2000 are repeated here for reference:

B.2.2.1 Brush any observed dust on the downstream side of the test unit onto the absolute filter. Carefully remove and reweigh the absolute filter pad and determine the increase in mass by comparison with the mass recorded in 7.5.2.2.

B.2.2.2 Collect all dust which has settled on exterior surfaces/ducting/test chamber or the inlet side of the test unit and transfer this dust to the original dust container. Transfer all unused dust in the dust feed device to the original dust container and reweigh the container and dust. By subtraction of this mass from the mass recorded in 7.5.2.3, determine the total mass of dust injected into the test unit.

B.2.2.3 If it is practicable, reweigh the complete unit under test.

B.2.2.4 Calculate the capacity, C , of the unit under test as follows:

$$C = m_D - \Delta m_F \quad (\text{B.1})$$

where

m_D is the mass of dust fed;

Δm_F is the increase in mass of the absolute filter.

B.2.2.5 Calculate the full-life efficiency, E_f , as a percentage, as follows:

$$E_f = \frac{m_D - \Delta m_F}{m_D} \times 100 \% \quad (\text{B.2})$$

where the symbols are as in Equation (B.1).

Bibliography

- [1] ISO/TS 11155-1, *Road vehicles — Air filters for passenger compartments — Part 1: Test for particulate filtration*

BSI - British Standards Institution

BSI is the independent national body responsible for preparing British Standards. It presents the UK view on standards in Europe and at the international level. It is incorporated by Royal Charter.

Revisions

British Standards are updated by amendment or revision. Users of British Standards should make sure that they possess the latest amendments or editions.

It is the constant aim of BSI to improve the quality of our products and services. We would be grateful if anyone finding an inaccuracy or ambiguity while using this British Standard would inform the Secretary of the technical committee responsible, the identity of which can be found on the inside front cover. Tel: +44 (0)20 8996 9000. Fax: +44 (0)20 8996 7400.

BSI offers members an individual updating service called PLUS which ensures that subscribers automatically receive the latest editions of standards.

Buying standards

Orders for all BSI, international and foreign standards publications should be addressed to Customer Services. Tel: +44 (0)20 8996 9001. Fax: +44 (0)20 8996 7001 Email: orders@bsigroup.com You may also buy directly using a debit/credit card from the BSI Shop on the Website <http://www.bsigroup.com/shop>

In response to orders for international standards, it is BSI policy to supply the BSI implementation of those that have been published as British Standards, unless otherwise requested.

Information on standards

BSI provides a wide range of information on national, European and international standards through its Library and its Technical Help to Exporters Service. Various BSI electronic information services are also available which give details on all its products and services. Contact Information Centre. Tel: +44 (0)20 8996 7111 Fax: +44 (0)20 8996 7048 Email: info@bsigroup.com

Subscribing members of BSI are kept up to date with standards developments and receive substantial discounts on the purchase price of standards. For details of these and other benefits contact Membership Administration. Tel: +44 (0)20 8996 7002 Fax: +44 (0)20 8996 7001 Email: membership@bsigroup.com

Information regarding online access to British Standards via British Standards Online can be found at <http://www.bsigroup.com/BSOL>

Further information about BSI is available on the BSI website at <http://www.bsigroup.com>

Copyright

Copyright subsists in all BSI publications. BSI also holds the copyright, in the UK, of the publications of the international standardization bodies. Except as permitted under the Copyright, Designs and Patents Act 1988 no extract may be reproduced, stored in a retrieval system or transmitted in any form or by any means – electronic, photocopying, recording or otherwise – without prior written permission from BSI.

This does not preclude the free use, in the course of implementing the standard, of necessary details such as symbols, and size, type or grade designations. If these details are to be used for any other purpose than implementation then the prior written permission of BSI must be obtained.

Details and advice can be obtained from the Copyright and Licensing Manager. Tel: +44 (0)20 8996 7070 Email: copyright@bsigroup.com