

BS ISO 10242-1:2011



BSI Standards Publication

Tools for pressing — Punch holder shanks

Part 1: Type A

bsi.

...making excellence a habit.™

National foreword

This British Standard is the UK implementation of ISO 10242-1:2011. It supersedes BS ISO 10242-1:1998 which is withdrawn.

The UK participation in its preparation was entrusted to Technical Committee MTE/12, Tools for pressing and moulding.

A list of organizations represented on this committee can be obtained on request to its secretary.

This publication does not purport to include all the necessary provisions of a contract. Users are responsible for its correct application.

© BSI 2011

ISBN 978 0 580 73924 8

ICS 25.120.10

Compliance with a British Standard cannot confer immunity from legal obligations.

This British Standard was published under the authority of the Standards Policy and Strategy Committee on 30 September 2011.

Amendments issued since publication

Date	Text affected
------	---------------

INTERNATIONAL
STANDARD

BS ISO 10242-1:2011

ISO
10242-1

Third edition
2011-09-15

**Tools for pressing — Punch holder
shanks —**

Part 1:
Type A

Outillage de presse — Nez de presse —

Partie 1: Type A



Reference number
ISO 10242-1:2011(E)

© ISO 2011



COPYRIGHT PROTECTED DOCUMENT

© ISO 2011

All rights reserved. Unless otherwise specified, no part of this publication may be reproduced or utilized in any form or by any means, electronic or mechanical, including photocopying and microfilm, without permission in writing from either ISO at the address below or ISO's member body in the country of the requester.

ISO copyright office
Case postale 56 • CH-1211 Geneva 20
Tel. + 41 22 749 01 11
Fax + 41 22 749 09 47
E-mail copyright@iso.org
Web www.iso.org

Published in Switzerland

Foreword

ISO (the International Organization for Standardization) is a worldwide federation of national standards bodies (ISO member bodies). The work of preparing International Standards is normally carried out through ISO technical committees. Each member body interested in a subject for which a technical committee has been established has the right to be represented on that committee. International organizations, governmental and non-governmental, in liaison with ISO, also take part in the work. ISO collaborates closely with the International Electrotechnical Commission (IEC) on all matters of electrotechnical standardization.

International Standards are drafted in accordance with the rules given in the ISO/IEC Directives, Part 2.

The main task of technical committees is to prepare International Standards. Draft International Standards adopted by the technical committees are circulated to the member bodies for voting. Publication as an International Standard requires approval by at least 75 % of the member bodies casting a vote.

Attention is drawn to the possibility that some of the elements of this document may be the subject of patent rights. ISO shall not be held responsible for identifying any or all such patent rights.

ISO 10242-1 was prepared by Technical Committee ISO/TC 29, *Small tools*, Subcommittee SC 8, *Tools for pressing and moulding*.

This third edition cancels and replaces the second edition (ISO 10242-1:1998), of which it constitutes a minor revision. In particular, the indication of surface textures has been updated in accordance with ISO 1302:2002.

ISO 10242 consists of the following parts, under the general title *Tools for pressing — Punch holder shanks*:

- *Part 1: Type A*
- *Part 2: Type C*
- *Part 3: Type D*

Tools for pressing — Punch holder shanks —

Part 1: Type A

1 Scope

This part of ISO 10242 specifies the interchangeability dimensions and tolerances, in millimetres, of punch holder shanks with neck and flats, type A, intended for use in press tools.

It gives guidance on the materials, and specifies the hardness and designation of punch holder shanks in accordance with this part of ISO 10242.

2 Dimensions

The dimensions of punch holder type A shank shall be in accordance with the indications of Figure 1 and Table 1.

Surface roughness values in micrometres

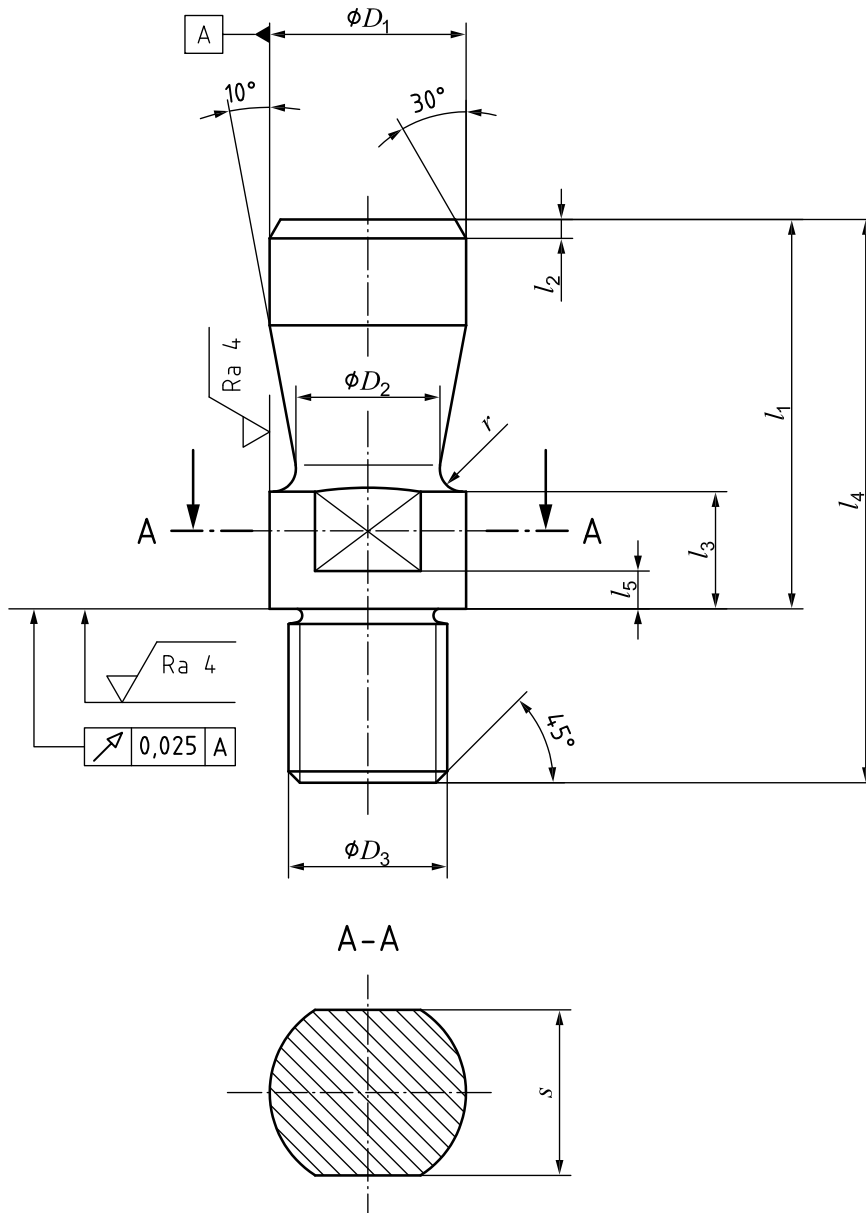
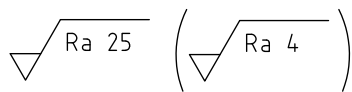

Figure 1 — Punch holder shank type A

Table 1 — Dimensions of punch holder shank type A

Dimensions in millimetres

D_1 f9	D_2	$D_3 \times P$ 6g	l_1	l_2	l_3	l_4	l_5 ± 1	r	s
20	15	M16 \times 1,5	40	2	12	58	4	2,5	17
25	20	M16 \times 1,5	45	2,5	16	68	6	2,5	21
		M20 \times 1,5							
32	25	M20 \times 1,5	56	3	16	79	6	2,5	27
		M24 \times 1,5							
40	32	M24 \times 1,5	70	4	26	93	12	4	36
		M27 \times 2							
		M30 \times 2							
50	42	M30 \times 2	80	5	26	108	12	4	41

3 Material and corresponding hardness

The material is left to the manufacturer's discretion, but the hardness shall be at least 140 HB.

4 Designation

A punch holder shank in accordance with this part of ISO 10242 shall be designated by:

- "Punch holder shank";
- reference to this part of ISO 10242, i.e. ISO 10242-1;
- its type;
- its body diameter, D_1 , in millimetres;
- its nominal thread diameter, D_3 .

EXAMPLE A punch holder shank of type A, of body diameter $D_1 = 20$ mm and of nominal thread diameter $D_3 = M16$ is designated as follows:

Punch holder shank ISO 10242-1 A-20 \times M16

Bibliography

- [1] ISO 1302:2002, *Geometrical Product Specifications (GPS) — Indication of surface texture in technical product documentation*
- [2] ISO 6506 (all parts), *Metallic materials — Brinell hardness test*

British Standards Institution (BSI)

BSI is the national body responsible for preparing British Standards and other standards-related publications, information and services.

BSI is incorporated by Royal Charter. British Standards and other standardization products are published by BSI Standards Limited.

About us

We bring together business, industry, government, consumers, innovators and others to shape their combined experience and expertise into standards-based solutions.

The knowledge embodied in our standards has been carefully assembled in a dependable format and refined through our open consultation process. Organizations of all sizes and across all sectors choose standards to help them achieve their goals.

Information on standards

We can provide you with the knowledge that your organization needs to succeed. Find out more about British Standards by visiting our website at bsigroup.com/standards or contacting our Customer Services team or Knowledge Centre.

Buying standards

You can buy and download PDF versions of BSI publications, including British and adopted European and international standards, through our website at bsigroup.com/shop, where hard copies can also be purchased.

If you need international and foreign standards from other Standards Development Organizations, hard copies can be ordered from our Customer Services team.

Subscriptions

Our range of subscription services are designed to make using standards easier for you. For further information on our subscription products go to bsigroup.com/subscriptions.

With **British Standards Online (BSOL)** you'll have instant access to over 55,000 British and adopted European and international standards from your desktop. It's available 24/7 and is refreshed daily so you'll always be up to date.

You can keep in touch with standards developments and receive substantial discounts on the purchase price of standards, both in single copy and subscription format, by becoming a **BSI Subscribing Member**.

PLUS is an updating service exclusive to BSI Subscribing Members. You will automatically receive the latest hard copy of your standards when they're revised or replaced.

To find out more about becoming a BSI Subscribing Member and the benefits of membership, please visit bsigroup.com/shop.

With a **Multi-User Network Licence (MUNL)** you are able to host standards publications on your intranet. Licences can cover as few or as many users as you wish. With updates supplied as soon as they're available, you can be sure your documentation is current. For further information, email bsmusales@bsigroup.com.

Revisions

Our British Standards and other publications are updated by amendment or revision.

We continually improve the quality of our products and services to benefit your business. If you find an inaccuracy or ambiguity within a British Standard or other BSI publication please inform the Knowledge Centre.

Copyright

All the data, software and documentation set out in all British Standards and other BSI publications are the property of and copyrighted by BSI, or some person or entity that owns copyright in the information used (such as the international standardization bodies) and has formally licensed such information to BSI for commercial publication and use. Except as permitted under the Copyright, Designs and Patents Act 1988 no extract may be reproduced, stored in a retrieval system or transmitted in any form or by any means – electronic, photocopying, recording or otherwise – without prior written permission from BSI. Details and advice can be obtained from the Copyright & Licensing Department.

Useful Contacts:

Customer Services

Tel: +44 845 086 9001

Email (orders): orders@bsigroup.com

Email (enquiries): cservices@bsigroup.com

Subscriptions

Tel: +44 845 086 9001

Email: subscriptions@bsigroup.com

Knowledge Centre

Tel: +44 20 8996 7004

Email: knowledgecentre@bsigroup.com

Copyright & Licensing

Tel: +44 20 8996 7070

Email: copyright@bsigroup.com

BSI Group Headquarters

389 Chiswick High Road London W4 4AL UK



...making excellence a habit.™