

BS ISO 10143:2014



BSI Standards Publication

**Carbonaceous materials for the
production of aluminium —
Calcined coke for electrodes —
Determination of the electrical
resistivity of granules**

bsi.

...making excellence a habit.™

National foreword

This British Standard is the UK implementation of ISO 10143:2014. It supersedes BS 6043-2.10:1996 which is withdrawn.

The UK participation in its preparation was entrusted to Technical Committee CII/24, Raw materials for the aluminium industry.

A list of organizations represented on this committee can be obtained on request to its secretary.

This publication does not purport to include all the necessary provisions of a contract. Users are responsible for its correct application.

© The British Standards Institution 2014. Published by BSI Standards Limited 2014

ISBN 978 0 580 81218 7

ICS 71.100.10

Compliance with a British Standard cannot confer immunity from legal obligations.

This British Standard was published under the authority of the Standards Policy and Strategy Committee on 31 July 2014.

Amendments issued since publication

Date	Text affected
------	---------------

**Carbonaceous materials for the
production of aluminium — Calcined
coke for electrodes — Determination
of the electrical resistivity of granules**

*Produits carbonés utilisés pour la production de l'aluminium — Coke
calciné — Détermination de la résistivité électrique granulaire*





COPYRIGHT PROTECTED DOCUMENT

© ISO 2014

All rights reserved. Unless otherwise specified, no part of this publication may be reproduced or utilized otherwise in any form or by any means, electronic or mechanical, including photocopying, or posting on the internet or an intranet, without prior written permission. Permission can be requested from either ISO at the address below or ISO's member body in the country of the requester.

ISO copyright office
Case postale 56 • CH-1211 Geneva 20
Tel. + 41 22 749 01 11
Fax + 41 22 749 09 47
E-mail copyright@iso.org
Web www.iso.org

Published in Switzerland

Contents

	Page
Foreword	iv
1 Scope	1
2 Normative references	1
3 Principle	1
4 Apparatus	1
5 Sampling and sample preparation	3
5.1 Sampling	3
5.2 Sample preparation calcined petroleum coke	3
5.3 Sample preparation all samples	3
6 Procedure	3
6.1 Test portion	3
6.2 Setting up the test machine	3
6.3 Determination	4
6.4 Number of determinations	4
7 Expression of results	4
8 Precision	4
8.1 Repeatability	4
8.2 Reproducibility	4
9 Test report	4

Foreword

ISO (the International Organization for Standardization) is a worldwide federation of national standards bodies (ISO member bodies). The work of preparing International Standards is normally carried out through ISO technical committees. Each member body interested in a subject for which a technical committee has been established has the right to be represented on that committee. International organizations, governmental and non-governmental, in liaison with ISO, also take part in the work. ISO collaborates closely with the International Electrotechnical Commission (IEC) on all matters of electrotechnical standardization.

The procedures used to develop this document and those intended for its further maintenance are described in the ISO/IEC Directives, Part 1. In particular the different approval criteria needed for the different types of ISO documents should be noted. This document was drafted in accordance with the editorial rules of the ISO/IEC Directives, Part 2 (see www.iso.org/directives).

Attention is drawn to the possibility that some of the elements of this document may be the subject of patent rights. ISO shall not be held responsible for identifying any or all such patent rights. Details of any patent rights identified during the development of the document will be in the Introduction and/or on the ISO list of patent declarations received (see www.iso.org/patents).

Any trade name used in this document is information given for the convenience of users and does not constitute an endorsement.

For an explanation on the meaning of ISO specific terms and expressions related to conformity assessment, as well as information about ISO's adherence to the WTO principles in the Technical Barriers to Trade (TBT) see the following URL: Foreword - Supplementary information

The committee responsible for this document is ISO/TC 226, *Materials for the production of primary aluminium*.

This second edition cancels and replaces the first edition (ISO 10143:1995), which has been technically revised.

Carbonaceous materials for the production of aluminium — Calcined coke for electrodes — Determination of the electrical resistivity of granules

1 Scope

This International Standard specifies a method for the determination of the electrical resistivity of granular carbon (calcined or graphitized) used in the manufacture of carbon electrodes for the production of aluminium.

The measurement of electrical resistivity assists in assessing the extent of coke calcination. The electrical resistivity of the coke aggregate will influence that of the coke electrodes made from it.

In general, a more highly calcined coke will have a lower electrical resistivity if other factors, such as grain size, are similar.

2 Normative references

The following documents, in whole or in part, are normatively referenced in this document and are indispensable for its application. For dated references, only the edition cited applies. For undated references, the latest edition of the referenced document (including any amendments) applies.

ISO 6375, *Carbonaceous materials for the production of aluminium — Coke for electrodes — Sampling*

ISO 6997, *Carbonaceous materials for the production of aluminium — Calcined coke — Determination of apparent oil content — Heating method*

ISO 8723, *Carbonaceous materials for the production of aluminium — Calcined coke — Determination of oil content — Method by solvent extraction*

ISO 11412, *Carbonaceous materials for the production of aluminium — Calcined coke — Determination of water content*

3 Principle

A test portion of the granular carbon is placed in a cylindrical holder which has electrical contacts at the top and bottom. A fixed pressure is applied to the test portion to ensure good electrical contact and a fixed, constant direct current is applied. The voltage drop and the height of the column of granules are measured and the electrical resistivity is calculated.

4 Apparatus

Ordinary laboratory apparatus, plus the following:

4.1 Sample holder and plunger, with removable base for cleaning as shown in [Figure 1](#).

4.2 Length-measuring device, capable of measuring the movement of the compression plunger to $\pm 0,02$ mm.

4.3 Brass reference cylinder, having a height of $20 \text{ mm} \pm 0,01 \text{ mm}$ and a diameter of 29 mm, used for calibrating the length-measuring device ([4.2](#)).

4.4 **Test machine**, capable of applying a constant pressure of 3 MPa \pm 1 % to the plunger (4.1). Giving a velocity to the plunger of not more than 50 mm/s and having a centering device for the sample holder (4.1).

4.5 **Power supply**, capable of providing a constant direct current of 1 A \pm 0,002 A.

4.6 **Voltmeter**, capable of measuring to the nearest \pm 0,01 mV.

4.7 **Oven**, capable of being maintained at 120 °C \pm 2 °C.

Dimensions in millimetres

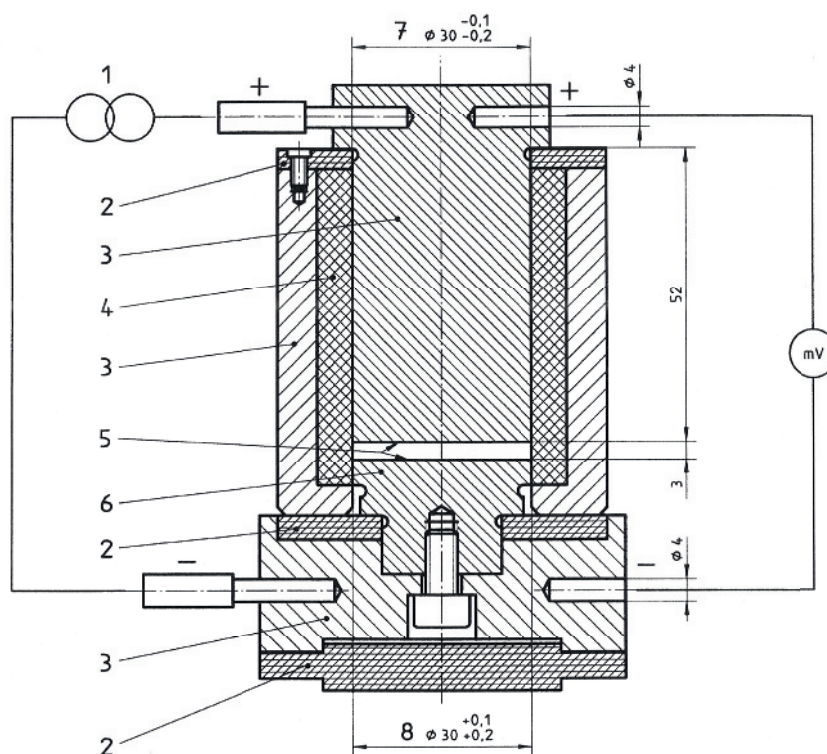

Key

- 1 power supply
- 2 PTFE
- 3 brass
- 4 agate
- 5 hard-chromed surfaces
- 6 stainless steel
- 7 plunger
- 8 mould

Figure 1 — Sample holder and plunger, showing electrical connections

5 Sampling and sample preparation

5.1 Sampling

Sample the coke in accordance with ISO 6375.

5.2 Sample preparation calcined petroleum coke

Heat the sample to $110\text{ °C} \pm 5\text{ °C}$ during 12 h, using the oven (4.7) in compliance with ISO 11412.

De-oil the sample by washing with dichloromethane in accordance with ISO 8723 or by heating in accordance with ISO 6997.

Crush all the sample material $>1,4\text{ mm}$ in a jaw crusher with a minimum aperture of $1,5\text{ mm}$ so that all the sample material passes the $1,4\text{ mm}$ sieve.

Sieve the fraction $1,4\text{ mm}$ to $1,0\text{ mm}$ for the analysis.

5.3 Sample preparation all samples

Divide the sample, by sieving, into three fractions (I, Ila, and III) as follows:

- fraction I $>1,0\text{ mm}$;
- fraction Ila $0,5\text{ mm}$ to $1,0\text{ mm}$;
- fraction III $<0,5\text{ mm}$.

Crush fraction I so that it is predominantly $0,5\text{ mm}$ to $1,0\text{ mm}$ and sieve to form fraction I Ib.

Mix fractions I la and I lb thoroughly.

Wash the sample with dichloromethane in accordance with ISO 8723.

Heat the sample to $120\text{ °C} \pm 2\text{ °C}$ for 30 min using the oven (4.7), allow to cool in a desiccator and weigh to the nearest 1 g or better. Repeat the operations of heating, cooling, and weighing until the difference between two successive weightings does not exceed 1 % of the original sample mass.

6 Procedure

6.1 Test portion

Weigh out $15\text{ g} \pm 0,1\text{ g}$ of the mixture of fraction $1,4\text{ mm}$ to $1,0\text{ mm}$ or of I la and I lb (5.3).

6.2 Setting up the test machine

Place the brass reference cylinder (4.3) in the sample holder (4.1).

Place the sample holder with plunger (4.1) in the test machine (4.4) and apply a pressure of 3 MPa. Set the length-measuring device (4.2) to the reference level of 20 mm. Connect up the electrical wires and switch on the power supply (4.5).

Place the sample holder with plunger (4.1) in the test machine (4.4) and apply a pressure of 3 MPa. Set the length-measuring device (4.2) to the reference level of 20 mm. Connect up the electrical wires and switch on the power supply (4.5).

6.3 Determination

Pour the test portion into the sample holder, insert the plunger and place the assembly in the test machine.

Apply a pressure of 3 MPa to the test portion and after 30 s record the voltage drop and the height of the column of granules.

6.4 Number of determinations

Carry out two determinations using a fresh test portion for each determination.

Clean the base and the plunger surfaces carefully after each determination.

7 Expression of results

Calculate the electrical resistivity, ρ , expressed in microhm metres, of the calcined coke using Formula (1):

$$\rho = \frac{S \times U}{I \times h} \quad (1)$$

where

S is the surface area, in square millimetres, of the sample holder (707 mm² for the sample holder shown in [Figure 1](#));

U is the voltage drop, in millivolts;

I is the current applied, in amps (1 A ± 0,002 A);

h is the height, in millimetres, of the column of granules.

Express the result as the arithmetic mean of two determinations.

8 Precision¹⁾

8.1 Repeatability

The difference between the values of duplicate determinations, carried out in rapid succession by the same operator using the same apparatus on granules taken from the same test sample, shall not exceed the repeatability limit $r = 3 \%$.

8.2 Reproducibility

The difference between the values of the average of duplicate determinations obtained by two laboratories using this method for the analysis of the same laboratory sample is not expected to exceed the reproducibility limit $R = 5 \%$.

9 Test report

The test report shall include the following information:

- a) all details necessary for complete identification of the sample;

1) ISO 5725:1986, *Precision of test methods — Determination of repeatability and reproducibility for a standard test method by inter-laboratory tests* (now withdrawn), was used to obtain the precision data.

- b) a reference to this International Standard (i.e. ISO 10143);
- c) the size distribution of the grain fraction used;
- d) the results, expressed in accordance with [Clause 7](#);
- e) the details of any unusual features noted during the determination;
- f) the details of any operation not included in this International Standard or in the International Standards to which reference is made, as well as any operation regarded as optional.

British Standards Institution (BSI)

BSI is the national body responsible for preparing British Standards and other standards-related publications, information and services.

BSI is incorporated by Royal Charter. British Standards and other standardization products are published by BSI Standards Limited.

About us

We bring together business, industry, government, consumers, innovators and others to shape their combined experience and expertise into standards-based solutions.

The knowledge embodied in our standards has been carefully assembled in a dependable format and refined through our open consultation process. Organizations of all sizes and across all sectors choose standards to help them achieve their goals.

Information on standards

We can provide you with the knowledge that your organization needs to succeed. Find out more about British Standards by visiting our website at bsigroup.com/standards or contacting our Customer Services team or Knowledge Centre.

Buying standards

You can buy and download PDF versions of BSI publications, including British and adopted European and international standards, through our website at bsigroup.com/shop, where hard copies can also be purchased.

If you need international and foreign standards from other Standards Development Organizations, hard copies can be ordered from our Customer Services team.

Subscriptions

Our range of subscription services are designed to make using standards easier for you. For further information on our subscription products go to bsigroup.com/subscriptions.

With **British Standards Online (BSOL)** you'll have instant access to over 55,000 British and adopted European and international standards from your desktop. It's available 24/7 and is refreshed daily so you'll always be up to date.

You can keep in touch with standards developments and receive substantial discounts on the purchase price of standards, both in single copy and subscription format, by becoming a **BSI Subscribing Member**.

PLUS is an updating service exclusive to BSI Subscribing Members. You will automatically receive the latest hard copy of your standards when they're revised or replaced.

To find out more about becoming a BSI Subscribing Member and the benefits of membership, please visit bsigroup.com/shop.

With a **Multi-User Network Licence (MUNL)** you are able to host standards publications on your intranet. Licences can cover as few or as many users as you wish. With updates supplied as soon as they're available, you can be sure your documentation is current. For further information, email bsmusales@bsigroup.com.

BSI Group Headquarters

389 Chiswick High Road London W4 4AL UK

Revisions

Our British Standards and other publications are updated by amendment or revision.

We continually improve the quality of our products and services to benefit your business. If you find an inaccuracy or ambiguity within a British Standard or other BSI publication please inform the Knowledge Centre.

Copyright

All the data, software and documentation set out in all British Standards and other BSI publications are the property of and copyrighted by BSI, or some person or entity that owns copyright in the information used (such as the international standardization bodies) and has formally licensed such information to BSI for commercial publication and use. Except as permitted under the Copyright, Designs and Patents Act 1988 no extract may be reproduced, stored in a retrieval system or transmitted in any form or by any means – electronic, photocopying, recording or otherwise – without prior written permission from BSI. Details and advice can be obtained from the Copyright & Licensing Department.

Useful Contacts:

Customer Services

Tel: +44 845 086 9001

Email (orders): orders@bsigroup.com

Email (enquiries): cservices@bsigroup.com

Subscriptions

Tel: +44 845 086 9001

Email: subscriptions@bsigroup.com

Knowledge Centre

Tel: +44 20 8996 7004

Email: knowledgecentre@bsigroup.com

Copyright & Licensing

Tel: +44 20 8996 7070

Email: copyright@bsigroup.com



...making excellence a habit.™