



BSI Standards Publication

Pneumatic fluid power — Electro-pneumatic continuous flow control valves

Part 2: Test methods to determine main characteristics to include in the supplier's literature

NO COPYING WITHOUT BSI PERMISSION EXCEPT AS PERMITTED BY COPYRIGHT LAW

raising standards worldwide[™]

Copyright British Standards Institution
Provided by IHS under license with BSI - Uncontrolled Copy
No reproduction or networking permitted without license from IHS

Not for Resale

National foreword

This British Standard is the UK implementation of ISO 10041-2:2010.

The UK participation in its preparation was entrusted to Technical Committee MCE/18/-/5, Control components.

A list of organizations represented on this committee can be obtained on request to its secretary.

This publication does not purport to include all the necessary provisions of a contract. Users are responsible for its correct application.

© BSI 2010

ISBN 978 0 580 66298 0

ICS 23.100.50

Compliance with a British Standard cannot confer immunity from legal obligations.

This British Standard was published under the authority of the Standards Policy and Strategy Committee on 30 November 2010.

Amendments issued since publication

Date	Text affected
------	---------------

**Pneumatic fluid power — Electro-
pneumatic continuous flow control
valves —**

**Part 2:
Test methods to determine main
characteristics to include in the
supplier's literature**

*Transmissions pneumatiques — Distributeurs électropneumatiques à
commande continue de débit —*

*Partie 2: Méthodes d'essai pour déterminer les principales
caractéristiques à inclure dans la documentation du fournisseur*



PDF disclaimer

This PDF file may contain embedded typefaces. In accordance with Adobe's licensing policy, this file may be printed or viewed but shall not be edited unless the typefaces which are embedded are licensed to and installed on the computer performing the editing. In downloading this file, parties accept therein the responsibility of not infringing Adobe's licensing policy. The ISO Central Secretariat accepts no liability in this area.

Adobe is a trademark of Adobe Systems Incorporated.

Details of the software products used to create this PDF file can be found in the General Info relative to the file; the PDF-creation parameters were optimized for printing. Every care has been taken to ensure that the file is suitable for use by ISO member bodies. In the unlikely event that a problem relating to it is found, please inform the Central Secretariat at the address given below.



COPYRIGHT PROTECTED DOCUMENT

© ISO 2010

All rights reserved. Unless otherwise specified, no part of this publication may be reproduced or utilized in any form or by any means, electronic or mechanical, including photocopying and microfilm, without permission in writing from either ISO at the address below or ISO's member body in the country of the requester.

ISO copyright office
Case postale 56 • CH-1211 Geneva 20
Tel. + 41 22 749 01 11
Fax + 41 22 749 09 47
E-mail copyright@iso.org
Web www.iso.org

Published in Switzerland

Contents

Page

Foreword	iv
Introduction.....	v
1 Scope	1
2 Normative references	1
3 Terms and definitions	2
4 Symbols and units.....	2
5 Test conditions	3
5.1 Gas supply	3
5.2 Temperature	3
5.3 Pressures	3
5.4 Electrical supply	3
6 Test procedure.....	3
6.1 Test conditions	3
6.2 Inlet pressure	3
6.3 Static tests	3
7 Tests to determine control signal-flow rate characteristics	4
7.1 Test circuits	4
7.2 Test procedures.....	7
7.3 Calculation of characteristics	12
8 Test to determine flow rate characteristics	14
8.1 Test circuit	14
8.2 Test procedures.....	14
8.3 Calculation of global characteristics.....	15
9 Test to determine pressure gain characteristics	16
9.1 General	16
9.2 Test circuit	16
9.3 Test procedure.....	17
9.4 Characteristic curve of pressure gain at null operating flow rate.....	17
10 Test to determine leakage at null operating flow rate characteristics.....	18
10.1 Test circuit	18
10.2 Test procedure.....	18
10.3 Calculation of characteristic	18
11 Test to determine dynamic characteristics	19
11.1 Test installation	19
11.2 Test to determine frequency response	19
11.3 Test to determine step responses	20
12 Presentation of test results	22
12.1 General	22
12.2 Control signal-flow rate characteristics	22
12.3 Global flow rate characteristics	23
12.4 Pressure gain characteristics at null operating flow rate	23
12.5 Leakage characteristic at null operating flow rate.....	23
12.6 Dynamic characteristics	23
13 Identification statement (reference to this part of ISO 10041)	24
Bibliography.....	25

Foreword

ISO (the International Organization for Standardization) is a worldwide federation of national standards bodies (ISO member bodies). The work of preparing International Standards is normally carried out through ISO technical committees. Each member body interested in a subject for which a technical committee has been established has the right to be represented on that committee. International organizations, governmental and non-governmental, in liaison with ISO, also take part in the work. ISO collaborates closely with the International Electrotechnical Commission (IEC) on all matters of electrotechnical standardization.

International Standards are drafted in accordance with the rules given in the ISO/IEC Directives, Part 2.

The main task of technical committees is to prepare International Standards. Draft International Standards adopted by the technical committees are circulated to the member bodies for voting. Publication as an International Standard requires approval by at least 75 % of the member bodies casting a vote.

Attention is drawn to the possibility that some of the elements of this document may be the subject of patent rights. ISO shall not be held responsible for identifying any or all such patent rights.

ISO 10041-2 was prepared by Technical Committee ISO/TC 131, *Fluid power systems*, Subcommittee SC 5, *Control products and components*.

ISO 10041 consists of the following parts, under the general title *Pneumatic fluid power — Electro-pneumatic continuous flow control valves*:

- *Part 1: Main characteristics to include in the supplier's literature*
- *Part 2: Test methods to determine main characteristics to include in the supplier's literature*

Introduction

In pneumatic fluid power systems, power is transmitted and controlled through a gas under pressure within a circuit.

Electro-pneumatic continuous flow control valves continuously modulate the pneumatic power of a system in response to a continuous electrical control signal and link the electrical control quantity to the effective section of each variable port of the output stage (flow rate stage). The mass flow rate that crosses each restriction depends on the downstream and upstream pressures and the type of gas.

When control of position or force, including position- or force-tracking of a pneumatic cylinder, is required, electro-pneumatic continuous flow control valves can be used to precisely modulate the mass flow rates entering or exiting each cylinder chamber, resulting in a precise positioning. It is therefore necessary to know some performance characteristics of these electro-pneumatic continuous flow control valves in order to determine their suitability for a particular application.

www.bsi.org.uk

Pneumatic fluid power — Electro-pneumatic continuous flow control valves —

Part 2:

Test methods to determine main characteristics to include in the supplier's literature

1 Scope

This part of ISO 10041 specifies the test procedures and a method of presenting the results concerning the parameters that define the main characteristics to be included in the supplier's literature of electro-pneumatic continuous flow control valves, in accordance with ISO 10041-1.

This part of ISO 10041 is intended to

- facilitate the comparison of these types of valves by standardizing test methods and the presentation of test results, and
- assist in the proper application of these valves in pneumatic systems.

The specified tests are not production tests to be carried out on each valve manufactured.

NOTE 1 Tests related to electro-pneumatic continuous pressure control valves are specified in ISO 10094-2.

NOTE 2 Tests described in this part of ISO 10041 are performed on valves with exhaust port(s) connected to the atmosphere except for two-port valves.

2 Normative references

The following referenced documents are indispensable for the application of this document. For dated references, only the edition cited applies. For undated references, the latest edition of the referenced document (including any amendments) applies.

ISO 1219-1, *Fluid power systems and components — Graphic symbols and circuit diagrams — Part 1: Graphic symbols for conventional use and data-processing applications*

ISO 5598, *Fluid power system and components — Vocabulary*

ISO 6358-1¹⁾, *Pneumatic fluid power — Determination of flow-rate characteristics of components — Part 1: General rules and test methods for steady-state flow*

ISO 10041-1:2010, *Pneumatic fluid power — Electro-pneumatic continuous flow control valves — Part 1: Main characteristics to include in the supplier's literature*

1) To be published.

3 Terms and definitions

For the purposes of this document, the terms and definitions given in ISO 5598 and ISO 10041-1 apply.

4 Symbols and units

For the purposes of this document, the symbols and units listed in Table 1 apply.

Table 1 — Symbols and units

Description	Symbol	SI Unit
Critical back-pressure ratio ^a	b	—
Sonic conductance	C	$\text{m}^3/(\text{s}\cdot\text{Pa})$ (ANR) ^c
Subsonic index	m	—
Atmospheric pressure	p_{atm}	Pa
Reference pressure ^c	p_0	Pa
Inlet port stagnation gauge pressure ^b	p_1	Pa
Working port stagnation gauge pressure ^b	p_2, p_4	Pa
Air exhaust port stagnation gauge pressure ^b	p_3, p_5	Pa
Cracking pressure	Δp_c	Pa
Hysteresis	H	%
Maximum hysteresis difference	$\Delta p_{2,h,\text{max}}$	Pa
Linearity	L	%
Maximum linearity difference	$\Delta p_{2,l,\text{max}}$	Pa
Volume flow rate at standard reference atmosphere	q_V	m^3/s (ANR) ^c
Volume flow rate related to the relief flow rate	$q_{V,r}$	m^3/s (ANR) ^c
Maximum volume flow rate related to the forward flow rate	$q_{V,f,\text{max}}$	m^3/s (ANR) ^a
Repeatability	r	%
Reference temperature	T_0	K
Inlet port temperature ^a	T_1	K
Working port temperature ^a	T_2	K
Electrical control signal	w ($w_{\text{start}}, w_{\text{stop}}$)	V, mA or digital signal
Resolution	S	%

^a Defined in ISO 6358-1.
^b See ISO 11727^[4].
^c Reference atmosphere is defined in ISO 8778^[2], i.e.: $T_0 = 293,15$ K, $p_0 = 100$ kPa (1 bar) and relative humidity of 65 %.

The graphic symbols used in Figures 1 to 4 and in Figures 6 to 8 are in accordance with ISO 1219-1.

5 Test conditions

5.1 Gas supply

Unless otherwise specified, testing shall be conducted with compressed air. If another gas is used, it shall be noted in the test report.

5.2 Temperature

The ambient, fluid and the control valve temperatures shall be maintained at $23\text{ °C} \pm 10\text{ °C}$ during all the tests.

5.3 Pressures

5.3.1 General

The specified pressures shall be maintained within $\pm 2\%$.

5.3.2 Inlet pressure

If possible, testing should be conducted at an inlet pressure of 630 kPa (6,3 bar). If this is not possible, the inlet pressure shall be selected from the values given in ISO 2944.

5.3.3 Verification

It shall be periodically verified that no pressure bleed of measuring instruments is obstructed by solid or liquid particles.

5.4 Electrical supply

The tests shall be carried out under nominal electrical conditions.

6 Test procedure

6.1 Test conditions

The valve under test shall be installed and operated in accordance with the manufacturer's application instructions.

6.2 Inlet pressure

During the static and dynamic tests specified in Clauses 7 to 11, the inlet pressure shall be maintained constant.

During the dynamic tests specified in Clause 11, a tank buffer as indicated in Figure 8 shall be used in order to reduce fluctuations in the inlet pressure.

6.3 Static tests

During the static tests specified in Clauses 7 to 10, as soon as steady-state conditions are reached, every series of measurements obtained under related specified test conditions shall be recorded. When these measurements are performed in a step-by-step manner, the test conditions shall be modified slowly to prevent instability.

NOTE Figures 1 to 4 and Figures 6 to 8 represent typical circuits that do not show the electrical supply circuit necessary to operate electrically modulated pneumatic valves and that do not contain all the necessary safety devices for protection against hazards that may be caused by the failure of a component or piping. It is important that those responsible for conducting the tests take into account the necessity to protect personnel and property.

7 Tests to determine control signal-flow rate characteristics

7.1 Test circuits

7.1.1 Test circuit with working port connected to the atmosphere

7.1.1.1 Figure 1 represents a typical test circuit for measuring the control signal-flow rate characteristics of a three-port valve when the working port is connected to atmosphere. This circuit diagram uses the test circuit specified in ISO 6358-1 for testing under steady-state conditions components that exhaust directly to atmosphere, with the following additional requirements:

- the valve under test shall be located in the circuit so that the inlet port is connected to the upstream transition connector and pressure-measuring tube;
- the flowmeter shall be located downstream of the valve under test, at the working port and not at the inlet port, in order to measure the actual operating flow rate, using downstream transition connector and pressure-measuring tube;
- items 11 and 12 are not required when using component under test for which the exhaust port cannot be connected.

7.1.1.2 The test circuit for five-port control valves is the same as the one shown in Figure 1, with the working port that is not being evaluated connected to atmosphere.

NOTE When possible, in the case of five-port valves, both working ports can be evaluated simultaneously when connected to the atmosphere using two flowmeters located downstream of the valve under test at both working ports.

7.1.1.3 The test circuit for two-port control valves is the same as the one shown in Figure 1, except that the component under test does not have any exhaust port.

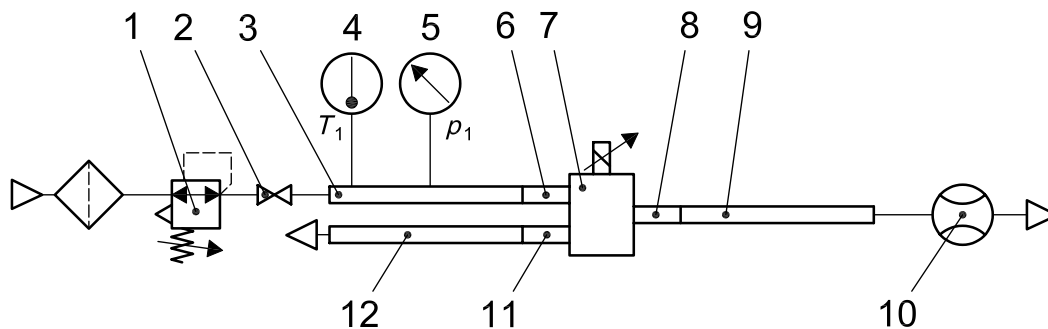

Key

- | | |
|----------|--|
| 1 | supply pressure regulator |
| 2 | shut-off valve |
| 3, 9, 12 | pressure-measuring tubes |
| 4 | sensor to measure inlet temperature T_1 |
| 5 | pressure gauge or transducer to measure inlet pressure p_1 |
| 6, 8, 11 | transition connectors |
| 7 | valve under test |
| 10 | flowmeter to measure operating mass flow rate |

Figure 1 — Test circuit for determining control signal-flow rate characteristics with the working port that is being evaluated connected to atmosphere

7.1.2 Test circuit to measure relief flow rate and forward flow rate

7.1.2.1 The test circuit to measure relief flow rate and forward flow rate shall be used to measure:

- the control signal-flow rate characteristic when the operating pressure is equal to the inlet pressure,
- the control signal-flow rate characteristic when the working port being evaluated is subjected to an intermediate pressure between the inlet and exhaust pressures,
- pressure-relief flow rate global characteristics,
- pressure-forward flow rate global characteristics.

7.1.2.2 Figure 2 represents a typical circuit for testing a three-port flow control valve. This circuit diagram combines:

- the test circuit for in-line test described in ISO 6358-1 for testing under steady-state conditions components with upstream and downstream pressure-measuring tubes (used for forward flow rates measurements), and
- the exhaust-to-atmosphere test circuit specified in ISO 6358-1 for testing under steady state conditions components that exhaust directly to atmosphere (used for relief flow rates measurements).

7.1.2.3 The test circuit for five-port control valves is the same as the one shown in Figure 2, with the working port that is being evaluated connected to the test circuit and the working port that is not being evaluated connected to atmosphere.

7.1.2.4 For testing two-port control valves (no exhaust port), the test circuit shown in Figure 2 is used only to measure forward flow rates.

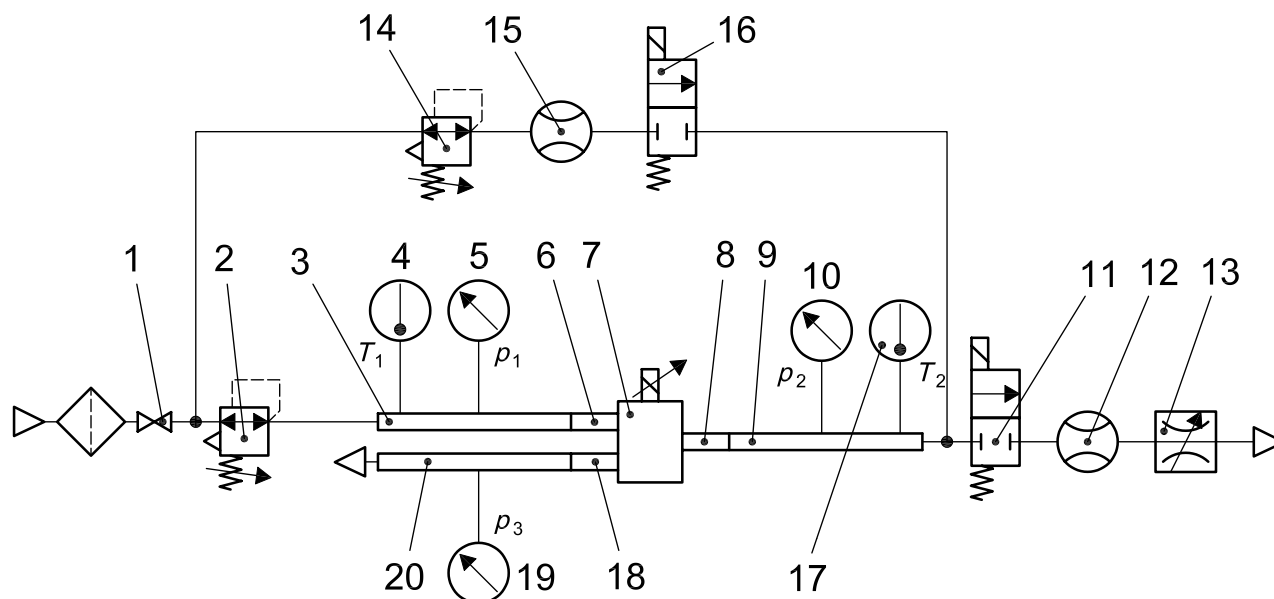

Key

- 1 inlet shut-off valve
- 2 inlet pressure regulator
- 3, 9, 20 pressure-measuring tubes
- 4 sensor to measure inlet temperature T_1
- 5 pressure gauge or transducer to measure inlet pressure p_1
- 6, 8, 18 transition connectors
- 7 valve under test
- 10 pressure gauge or transducer for measuring operating pressure p_2
- 11, 16 solenoid valves
- 12 flowmeter to measure forward flow rate
- 13 flow control valve to regulate forward flow rates
- 14 operating pressure regulator for relief flow rates
- 15 flowmeter to measure relief flow rate
- 17 sensor to measure temperature T_2 for relief flow rates
- 19 pressure gauge or transducer to measure relief pressure p_3

Figure 2 — Test circuit for measuring relief flow rate and forward flow rate

7.1.3 General requirements

- The component under test shall be located in the test circuit so as to connect all ports to the transition connectors and pressure-measuring tubes. Items 18, 19 and 20 are not required when using component under test for which the exhaust port cannot be connected.
- Transition connectors 6, 8 and 18 and pressure-measuring tubes 3, 9 and 20 shall be in accordance with ISO 6358-1.
- Components 1 to 6 correspond to the upstream part of the test circuit used for forward flow rates measurements. These components shall be used also for relief flow rate measurements as the inlet port of the component under test shall be connected to the supply circuit, following the normal use of the component.
- Components 8 to 13 correspond to the downstream part of the test circuit used for forward flow rates measurements.

- The sonic conductances of the inlet pressure regulator and of the solenoid valve 11 should be at least twice the forward sonic conductance of the component under test.
- Components 8, 9, 10, 14, 15, 16 and 17 correspond to the upstream part of the test circuit used for relief flow rates measurements.
- The sonic conductances of the pressure regulator of the relief flow rate use and of the solenoid valve 16 should be at least twice the relief sonic conductance of the component under test.
- The flow-meters 12 and 15 shall always be located at the working port in order to measure the actual forward or relief flow rate.

7.2 Test procedures

7.2.1 General

7.2.1.1 During the procedures specified in 7.2.2 to 7.2.4, measure the flow rate at a sufficient number of electrical control signal values to identify any possible non-linearities when the electrical control signal is varied throughout its full scale.

7.2.1.2 The procedures specified in 7.2.2 to 7.2.4 are written for testing three-port valves; when used to test five-port valves, these same procedures apply to the testing of the valve's port 2. However, the procedures for testing port 4 of five-port valves are different, and these modifications are given at the beginning of each procedure. Procedure 7.2.3 does not apply to two-port valves.

7.2.2 Test to determine control signal-flow rate characteristics with working port connected to the atmosphere

7.2.2.1 Install the valve under test in accordance with the test circuit specified in 7.1.1 and Figure 1 so that the flow rate at the working port being evaluated can be measured. Apply the inlet pressure chosen in 5.3.2 to the inlet port, and maintain it within the tolerance specified in 5.3.1 during the test.

7.2.2.2 To test a three-port valve, a two-port valve or port 2 of a five-port valve, conduct the procedures specified in 7.2.2.3 to 7.2.2.6. To test port 4 of a five-port valve, conduct the procedures specified in 7.2.2.3 to 7.2.2.6 but reverse the application of the electrical control signal indicated in 7.2.2.3, 7.2.2.4 and 7.2.2.6, that is, apply the minimum electrical control signal and increase it to its maximum value and then decrease it back to its minimum.

7.2.2.3 Apply the maximum electrical control signal. When the flow rate reaches a steady-state condition, measure the operating flow rate, which in this case would be equal to the forward flow rate.

7.2.2.4 Gradually decrease the electrical control signal.

7.2.2.5 For each electrical control signal value, after the flow rate reaches a steady-state condition, measure the operating flow rate.

7.2.2.6 Repeat the procedures described in 7.2.2.4 and in 7.2.2.5 until the minimum value of the electrical control signal is reached or until the flow rate is null. Then increase the electrical control signal and measure the flow rate at the same electrical control signal values used during the decreasing of the electrical control signal, until the maximum value of the electrical control signal is reached.

7.2.3 Test to determine control signal-flow rate characteristics for the inlet pressure

7.2.3.1 Install the valve under test in accordance with the test circuit specified in 7.1.2 and Figure 2 so that the flow rate at the working port being evaluated can be measured. During the installation, shut-off valve 1, solenoid valves 11 and 16 shall be closed.

7.2.3.2 Open shut-off valve 1 and solenoid valve 16 and set the pressure regulators 2 and 14 to apply the inlet pressure chosen in 5.3.2 to the inlet port and working port being evaluated and maintain it within the tolerance specified in 5.3.1 during the test.

7.2.3.3 To test a three-port valve or port 2 of a five-port valve, conduct the procedures specified in 7.2.3.4 to 7.2.3.7. To test port 4 of a five-port valve, conduct the procedures specified in 7.2.3.4 to 7.2.3.7 but reverse the application of the electrical control signal indicated in 7.2.3.4, 7.2.3.5 and 7.2.3.7, that is, apply the minimum electrical control signal and increase it to its maximum value and then decrease it back to its minimum.

7.2.3.4 Apply the maximum electrical control signal. When the flow rate reaches a steady-state condition, measure the operating flow rate, which in this case would be equal to the relief flow rate.

7.2.3.5 Gradually decrease the electrical control signal. Readjust, if necessary, the pressure regulator 14 so that the pressure at the working port (upstream pressure) remains constant.

7.2.3.6 For each electrical control signal value, after the flow rate reaches a steady-state condition, measure the operating flow rate.

7.2.3.7 Repeat the procedures specified in 7.2.3.5 and in 7.2.3.6 until the minimum value of the electrical control signal is reached. Then increase the electrical control signal and measure the flow rate at the same electrical control signal values used during the decreasing of the electrical control signal, until the maximum value of the electrical control signal is reached.

7.2.4 Test to determine control signal-flow rate characteristics at intermediate operating pressure

7.2.4.1 Initial test procedure

7.2.4.1.1 Install the valve under test in accordance with the test circuit specified in 7.1.2 and Figure 2 so that the flow rate at the working port being evaluated can be measured. During the installation, shut-off valve 1, solenoid valves 11 and 16, and flow control valve 13 shall be closed.

7.2.4.1.2 Open shut-off valve 1 and while the flow control valve is closed so that there is no flow, set the pressure regulator 2 to apply the inlet pressure chosen in 5.3.2 to the inlet port (upstream pressure), and maintain it within the tolerance specified in 5.3.1 during the test.

7.2.4.1.3 To test a two-port valve, conduct the procedures specified in 7.2.4.4 for forward flow rates. To test another valve, conduct successively the procedures specified in 7.2.4.2 for forward flow rates and then the procedures specified in 7.2.4.3 for relief flow rates.

7.2.4.2 Test to determine control signal-forward flow rate characteristics

7.2.4.2.1 To test a three-port valve or port 2 of a five-port valve, conduct the procedures specified in 7.2.4.2.2 to 7.2.4.2.7. To test port 4 of a five-port valve, conduct the procedures specified in 7.2.4.2.2 to 7.2.4.2.7 but reverse the application of the electrical control signal indicated in 7.2.4.2.2, 7.2.4.2.3 and 7.2.4.2.6, that is, apply the maximum electrical control signal and decrease it to its minimum value and then increase it back until the flow rate reaches null.

7.2.4.2.2 Open the solenoid valve 11. While maintaining the flow control valve closed, apply the minimum electrical control signal and then gradually increase it so that the operating pressure (that is, the pressure measured in the downstream pressure-measuring tube) reaches the inlet pressure, p_1 , minus 100 kPa (1 bar). It is important to reach this value during the increase in the electrical control signal. Record the corresponding electrical control signal value.

7.2.4.2.3 Slightly increase the electrical control signal.

7.2.4.2.4 Adjust the flow control valve to set the operating pressure of the valve under test so that this value remains constant at 100 kPa (1 bar) lower than the inlet pressure.

7.2.4.2.5 When the flow rate reaches a steady-state condition, measure the operating flow rate (forward flow rate) using the flowmeter. Report the corresponding value of the electrical control signal.

7.2.4.2.6 Repeat the procedures specified in 7.2.4.2.3 and in 7.2.4.2.5 by gradually increasing the electrical control signal until its maximum value is reached. Then decrease the electrical control signal and measure the flow rate at the same electrical control signal values used during the increasing of the electrical control signal, until it reaches null. Report the corresponding electrical control signal value.

7.2.4.2.7 Without modifying the electrical control signal value, close solenoid valve 11 and conduct the procedures specified in 7.2.4.3.

7.2.4.3 Test to determine control signal-relief flow rate characteristics

7.2.4.3.1 To test a three-port valve or port 2 of a five-port valve, conduct the procedures specified in 7.2.4.3.2 to 7.2.4.3.5. To test port 4 of a five-port valve, conduct the procedures specified in 7.2.4.3.2 to 7.2.4.3.5 but reverse the application of the electrical control signal indicated in 7.2.4.3.3 and in 7.2.4.3.5, that is, increase the electrical control signal to its maximum value and then decrease it back until flow rate reaches null.

7.2.4.3.2 Open solenoid valve 16 and set the pressure regulator 14 to apply to the working port being evaluated the inlet pressure minus 100 kPa (1 bar) and maintain it within the tolerance specified in 5.3.1 during the test.

7.2.4.3.3 Slightly decrease the electrical control signal and using the pressure regulator 14, readjust, if necessary, the operating pressure of the control valve (upstream pressure) so that its value remains constant at a value equal to the inlet pressure minus 100 kPa (1 bar).

7.2.4.3.4 When the flow rate reaches steady-state conditions, measure the operating flow rate (relief flow rate) with the flowmeter. Report the corresponding value of the electrical control signal.

7.2.4.3.5 Repeat the operations described in 7.2.4.3.3 and in 7.2.4.3.4 by gradually decreasing the electrical control signal until its minimum value is reached. Then increase the electrical control signal and measure the flow rate at the same electrical control signal values used during the decreasing of the electrical control signal, until flow rate reaches null.

7.2.4.4 Test to determine control signal-forward flow rate characteristics for a two-port valve

7.2.4.4.1 Open the solenoid valve 11 and maintaining the flow control valve closed, apply the maximum electrical control signal.

7.2.4.4.2 Adjust the flow control valve 13 to set the operating pressure of the valve under test so that this value remains constant at 100 kPa (1 bar) lower than the inlet pressure.

7.2.4.4.3 When the flow rate reaches a steady-state condition, measure the operating flow rate (forward flow rate) using the flowmeter. Report the corresponding value of the electrical control signal.

7.2.4.4.4 Slightly decrease the electrical control signal.

7.2.4.4.5 Repeat the procedures specified in 7.2.4.4.2 and in 7.2.4.4.4 by gradually decreasing the electrical control signal until its minimum value is reached. Then increase the electrical control signal and measure the flow rate at the same electrical control signal values used during the decreasing of the electrical control signal, until its maximum value is reached.

7.2.5 Test to determine resolution

7.2.5.1 The resolution test is done with the working port connected to atmosphere. Due to the significant time response of the flowmeter, the electrical control signal used for the resolution test is the position signal of the valving element of the valve under test, that is, a displacement of the valving element will induce a change

in the operating flow rate. If the control valve includes an internal valving element position sensor, that signal shall be used. Otherwise, it is necessary to add an external valving element position sensor.

7.2.5.2 Use X-Y recorder or another appropriate electronic equipment to record the electrical control signal in the X-axis and the position signal in the Y-axis as shown in Figure 3.

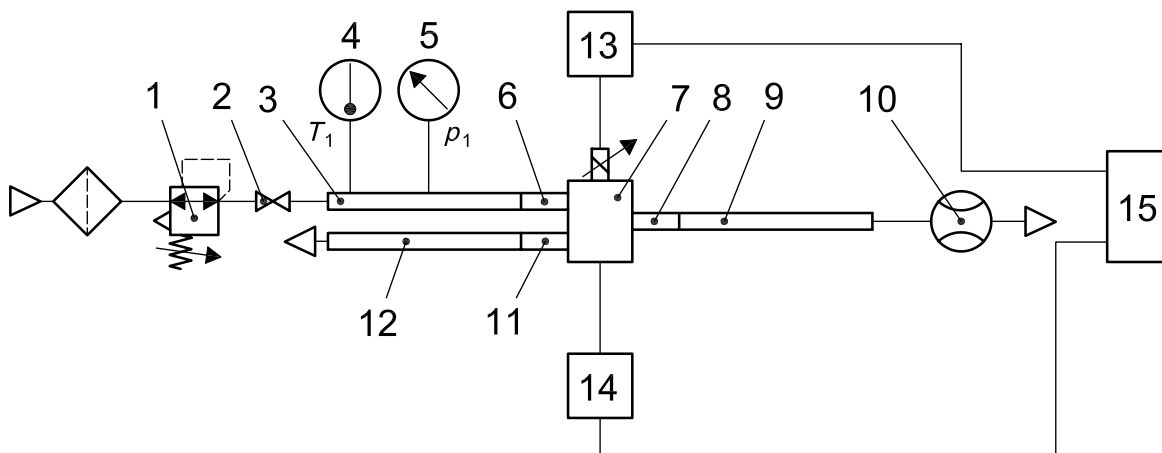

Key

- 1 supply pressure regulator
- 2 shut-off valve
- 3, 9, 12 pressure-measuring tube
- 4 sensor to measure inlet temperature T_1
- 5 pressure gauge or transducer to measure inlet pressure p_1
- 6, 8, 11 transition connector
- 7 valve under test
- 10 flowmeter to measure operating mass flow rate
- 13 signal generator
- 14 position sensor
- 15 recorder

Figure 3 — Circuit for resolution test

7.2.5.3 When evaluating a five-port valve, the procedures specified in 7.2.5.4 to 7.2.5.8 shall be conducted only on working port 2.

7.2.5.4 Install the valve under test in accordance with the test circuit shown in Figure 3 so that the flow rate at the working port being evaluated can be measured. Apply the inlet pressure chosen in 5.3.2 and maintain it within the tolerance specified in 5.3.1.

7.2.5.5 Apply the minimum electrical control signal, and gradually increase it until it reaches a value corresponding to 15 % of the maximum flow rate determined in 7.2.2. Record the value of the electrical control signal at this point as w_{stop} .

7.2.5.6 Stop the increase in the electrical control signal, and record the change in the position of the valving element as a function of the electrical signal.

7.2.5.7 Maintain this state for at least 10 s and gradually increase the electrical control signal. Record the value of the electrical control signal at which the valving element starts to move again as w_{start} .

7.2.5.8 Repeat the procedures specified in 7.2.5.6 and in 7.2.5.7 for the electrical control signal values corresponding to 50 % and 85 % of the maximum flow rate determined in 7.2.2 by gradually increasing the electrical control signal until these flow rates are reached.

7.2.6 Test to determine repeatability

7.2.6.1 The repeatability test shall be conducted with the working port connected to atmosphere.

7.2.6.2 Use an oscilloscope or another appropriate electronic equipment to record the time-dependent electrical control and flow rate signals as shown in Figure 4.

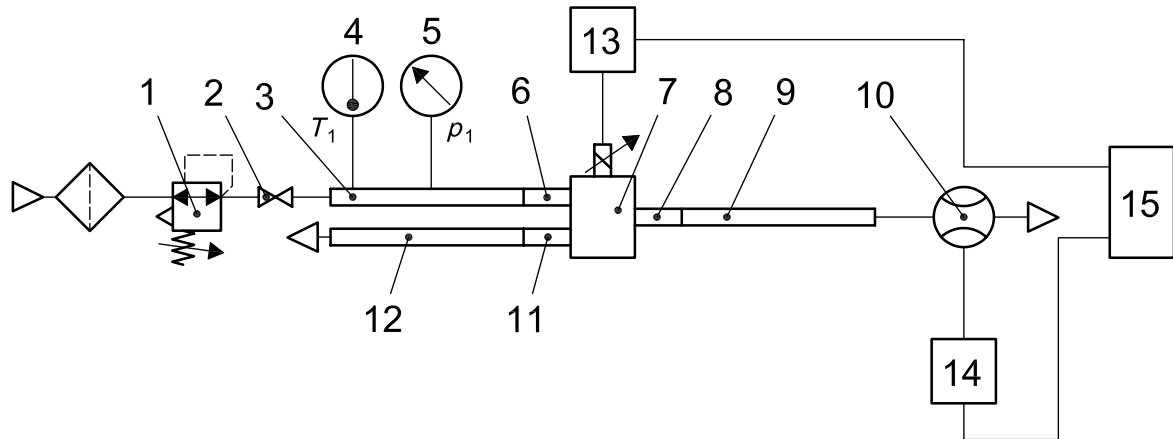

Key

- 1 supply pressure regulator
- 2 shut-off valve
- 3, 9, 12 pressure-measuring tube
- 4 sensor to measure inlet temperature T_1
- 5 pressure gauge or transducer to measure inlet pressure p_1
- 6, 8, 11 transition connector
- 7 valve under test
- 10 flowmeter to measure operating mass flow rate
- 13 signal generator
- 14 position sensor
- 15 recorder

Figure 4 — Circuit for repeatability test

7.2.6.3 When evaluating a five-port valve, the procedures specified in 7.2.6.4 to 7.2.6.6 shall be conducted only on working port 2.

7.2.6.4 Using a signal generator to create a square signal between 0 % and 50 % of the full scale of the electrical control signal, record the flow rate as a function of time for at least 20 cycles.

7.2.6.5 The frequency of the electrical control signal shall be sufficiently low to allow the flow rate to stabilise at 0 % and 50 % of the full scale of the electrical control signal.

7.2.6.6 At each cycle indicated by the index $j = 1, \dots, 20$, when the flow rate stabilises at 50 % of the full scale of the electrical control signal, record the corresponding flow rate as $q_{v,j}$.

7.3 Calculation of characteristics

7.3.1 Characteristic curves

7.3.1.1 To create characteristic curves for a three-port valve or a two-port valve, follow the procedures specified in 7.3.1.2 to 7.3.1.4. To create characteristic curves for a five-port valve, follow the procedures specified in 7.3.1.2 to 7.3.1.4 for each working port evaluated.

7.3.1.2 For characteristics in cases where operating pressure equals the exhaust pressure, calculate for each electrical control signal value the mean value of two corresponding operating flow rates (forward flow rates) measured in accordance with 7.2.2 with, respectively, the electrical control signal decreasing and increasing.

7.3.1.3 Repeat the calculation procedure for cases where:

- the operating pressure equals the inlet pressure (except for a two-port valve), using the corresponding operating flow rates (relief flow rates) measured in accordance with 7.2.3, and
- operating pressure equals the inlet pressure minus 100 kPa (1 bar), using the corresponding values of operating flow rate measured in accordance with 7.2.4 (forward flow rates for a two-port valve, forward flow rates and relief flow rates for an other valve).

7.3.1.4 For each operating pressure value, graph the mean flow rate values calculated in 7.3.1.2 and in 7.3.1.3 as a function of the electrical control signal as shown in ISO 10041-1:2010, Figure 1, taking into account the following rules:

- forward flow rates are shown as positive values in the first and second quadrants;
- relief flow rates are shown as negative values in the third and fourth quadrants.

7.3.2 Control signal-flow rate hysteresis

7.3.2.1 The control signal-flow rate hysteresis shall be calculated using the control signal-flow rate data obtained for three different operating pressures as specified in 7.2.2 to 7.2.4 (for two different operating pressures in the case of a two-port valve).

7.3.2.2 For each operating pressure value (p_{atm} , $p_1 - 100$ kPa, and p_1) and for each electrical control signal value between -95% and $+95\%$ of the full scale of the electrical control signal, calculate as an absolute value, the difference between the flow rate values q_V measured at, respectively, increasing and decreasing electrical control signal. In the case of a five-port valve, the flow rate data from tests of both ports shall be used. In the case of a two-port valve, apply this procedure for only two operating pressures (p_{atm} and $p_1 - 100$ kPa).

7.3.2.3 Determine the maximum hysteresis difference, $\Delta q_{V,h,\text{max}}$, as shown in Figure 5 for a three-port valve. Calculate the hysteresis characteristic value, H , as a percentage of the flow rate range in accordance with Equation (1):

$$H = \frac{|\Delta q_{V,h,\text{max}}|}{q_{V,f,\text{max}} + q_{V,r,\text{max}}} \times 100 \quad (1)$$

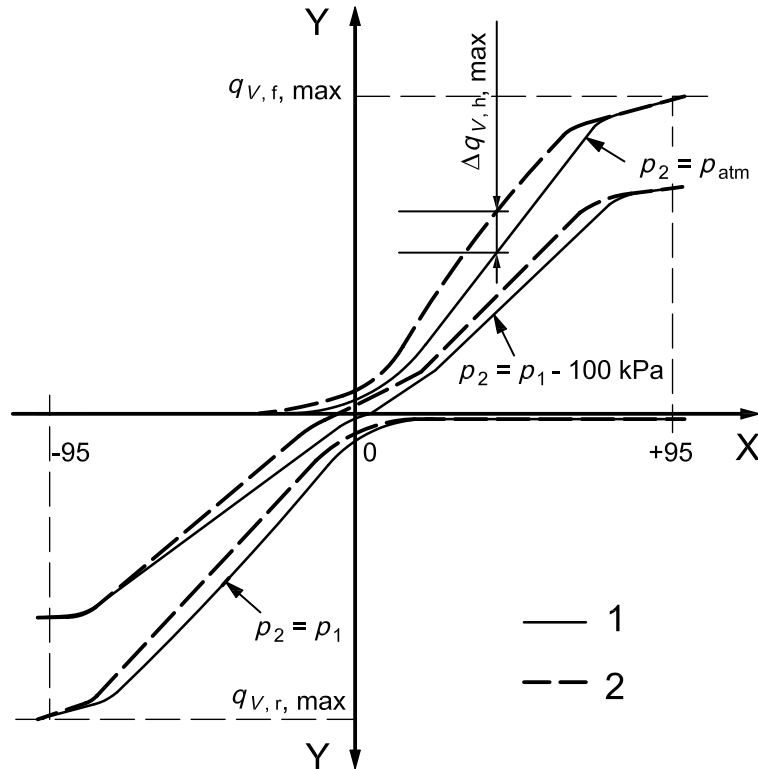

Key

- X electrical control signal, in %
- Y operating flow rate, in dm³/s (ANR)
- 1 increasing signal
- 2 decreasing signal

Figure 5 — Representation of the maximum hysteresis difference

7.3.3 Resolution

7.3.3.1 For each of the three tests conducted in accordance with 7.2.5, for electrical control signal values corresponding to 15 %, 50 % and 85 % of the maximum flow rate, calculate the corresponding resolution, *S*, expressed as a percentage of the full scale of the electrical control signal, using Equation (2):

$$S = \frac{w_{\text{start}} - w_{\text{stop}}}{w_{\text{max}} - w_{\text{min}}} \times 100 \quad (2)$$

7.3.3.2 Report the maximum of the three values calculated in 7.3.3.1 as the resolution.

7.3.4 Repeatability

Using the stabilised flow rate values, $q_{V,j}$, obtained in accordance with 7.2.6, calculate the repeatability, *r*, value expressed as a percentage of the maximum flow rate obtained in 7.2.2, using Equation (3):

$$r = \frac{q_{V,j,\text{max}} - q_{V,j,\text{min}}}{q_{V,\text{max}}} \times 100 \quad (3)$$

8 Test to determine flow rate characteristics

8.1 Test circuit

To measure the flow rate characteristics of valves, a circuit conforming to the requirements specified in 7.1.2 and in Figure 2 shall be used.

8.2 Test procedures

8.2.1 Test to determine pressure-forward flow rate global characteristics

8.2.1.1 Install the valve under test in the test circuit so that the flow rate at the working port being evaluated can be measured. During the installation, shut-off valve, solenoid valves 11 and 16, and flow control valve 13 shall be closed.

8.2.1.2 Open shut-off valve 1 and while the flow control valve is closed so that there is no flow, set the pressure regulator 2 to apply the inlet pressure chosen in 5.3.2 to the inlet port (upstream pressure), and maintain it within the tolerance specified in 5.3.1 during the test.

8.2.1.3 To test a two-port valve, a three-port valve or port 2 of a five-port valve, apply the maximum value (+100 %) of the electrical control signal. To test port 4 of a five-port valve, apply the minimum value (–100 %) of the electrical control signal.

8.2.1.4 Open solenoid valve 11 and determine the steady-state flow rate characteristics of the valve under test in accordance with ISO 6358-1, using the procedure that requires upstream and downstream flow measuring tubes, using the flow control valve.

8.2.1.5 Repeat 8.2.1.4 at electrical control signals equal to

- +60 % and +20 % of the electrical control signal when testing a two-port valve, a three-port valve or working port 2 of a five-port valve, et
- –60 % and –20 % of the electrical control signal when testing working port 4 of a five-port valve.

8.2.2 Test to determine pressure-relief flow rate global characteristics

8.2.2.1 Install the valve under test in the circuit so that the flow rate at the working port being evaluated can be measured. During the installation, shut-off valve, solenoid valves 11 and 16, and flow control valve shall be closed.

8.2.2.2 Open shut-off valve and while the flow control valve is closed so that there is no flow, set the pressure regulator 2 to apply the inlet pressure chosen in 5.3.2 to the inlet port (upstream pressure), and maintain it within the tolerance specified in 5.3.1 during the test.

8.2.2.3 To test a three-port valve or working port 2 of a five-port valve, apply the minimum value (–100 %) of the electrical control signal. To test working port 4 of a five-port valve, apply the maximum value (+100 %) of the electrical control signal.

8.2.2.4 Open solenoid valve 16 and set the pressure regulator 14 to the working port being evaluated to apply the inlet pressure chosen in 5.3. Determine the steady-state flow rate characteristics of the valve under test in accordance with ISO 6358-1, using the procedure for components that exhaust directly to atmosphere, with the value of upstream pressure (operating pressure) being adjusted by the pressure regulator 14.

8.2.2.5 Repeat 8.2.2.3 for electrical control values equal to

- -60 % and -20 % of the electrical control signal when testing a three-port valve or working port 2 of a five-port valve, and
- +60 % and +20 % of the electrical control signal when testing working port 4 of a five-port valve.

8.3 Calculation of global characteristics

8.3.1 Calculation of flow rate global characteristics

8.3.1.1 Forward flow rate global characteristics

From the results obtained in accordance with 8.2.1, calculate the forward flow rate characteristics using the calculation method specified in ISO 6358-1 for components tested with upstream and downstream measuring tubes. These forward flow rate characteristics shall include the sonic conductance C and the critical back-pressure ratio, b . When appropriate, the subsonic index, m , or the cracking pressure, Δp_C , or both, shall also be determined. These characteristics shall be calculated

- for the maximum electrical control signal value in the case of a two-port valve or of a three-port valve or of the working port 2 of a five-port valve, and
- for the minimum electrical control signal value in the case of the working port 4 of a five-port valve.

8.3.1.2 Relief flow rate global characteristics

From the results obtained in accordance with 8.2.2, calculate the relief flow rate characteristics using the calculation method specified in ISO 6358-1 for components that exhaust directly to atmosphere. These relief flow rate characteristics shall include the sonic conductance, C , and the critical back-pressure ratio, b . When appropriate, the subsonic index, m , or the cracking pressure, Δp_C , or both, shall also be determined. These characteristics shall be calculated

- for the minimum electrical control signal value, in the case of a three-port valve or of working port 2 of a five-port valve, and
- for the maximum electrical control signal, in the case of working port 4 of a five-port valve.

8.3.2 Pressure-flow rate global characteristic curves

8.3.2.1 Two-port valves

For each electrical control signal value, plot in a graph the values of the operating flow rates obtained in accordance with 8.2.1 as a function of the pressure ratio $(p_2 + p_{atm})/(p_1 + p_{atm})$, as represented in the first quadrant of ISO 10041-1:2010, Figure 2 a).

8.3.2.2 Three-port valves

For each electrical control signal value higher than the median value, plot in a graph the values of the operating flow rates obtained in accordance with 8.2.1 as a function of the pressure ratio $(p_2 + p_{atm})/(p_1 + p_{atm})$, as represented in the first quadrant of ISO 10041-1:2010, Figure 2 b).

For each electrical control signal value lower than the median value, plot in a graph the values of the operating flow rates obtained in accordance with 8.2.2 as a function of the pressure ratio $(p_3 + p_{atm})/(p_2 + p_{atm})$, as represented in the fourth quadrant of ISO 10041-1:2010, Figure 2 b).

8.3.2.3 Five-port valves

8.3.2.3.1 Symmetrical valve

If the valve is symmetric, apply the procedure described in 8.3.2.2 for three-port valves for the values of the operating flow rates obtained for working port 2.

8.3.2.3.2 Non symmetrical valve

- For each electrical control signal value higher than the median value:
 - plot in a graph the values of the operating flow rates at working port 2 obtained in accordance with 8.2.1 (forward flow rate) as a function of the pressure ratio $(p_2 + p_{atm})/(p_1 + p_{atm})$, as represented in the first quadrant of ISO 10041-1:2010, Figure 3 a);
 - plot in a graph the values of the operating flow rates at working port 4, obtained in accordance with 8.2.2 (relief flow rate), as a function of the pressure ratio $(p_5 + p_{atm})/(p_4 + p_{atm})$, as represented in the fourth quadrant of ISO 10041-1:2010, Figure 3 a).
- For each electrical control signal value lower than the median value:
 - plot in a graph the values of the operating flow rates at working port 2, obtained in accordance with 8.2.2 (relief flow rate), as function of the pressure ratio $(p_3 + p_{atm})/(p_2 + p_{atm})$, as represented in the fourth quadrant of ISO 10041-1:2010, Figure 3 b);
 - plot in a graph the values of the operating flow rates at working port 4, obtained in accordance with 8.2.1 (forward flow rate), as a function of the pressure ratio $(p_4 + p_{atm})/(p_1 + p_{atm})$, as represented in the first quadrant of ISO 10041-1:2010, Figure 3 b).

9 Test to determine pressure gain characteristics

9.1 General

The purpose of the test is to determine the pressure gain characteristics at the working port(s) in relation to the electrical control signal at null operating flow rate(s).

9.2 Test circuit

Figure 6 represents a typical test circuit for determining the pressure gain of a three-port valve at null operating flow rate. Figure 6 uses the upstream part of the test circuit for in-line test described in ISO 6358-1. The connector, which measures the operating pressure, is plugged to guarantee a null operating flow rate. The length (volume) of this connector with pressure-measuring tap shall be as short (small) as possible.

For five-port control valves, the test circuit is similar; however, both connectors that measure the operating pressures p_2 and p_4 are plugged to guarantee null operating flow rates.

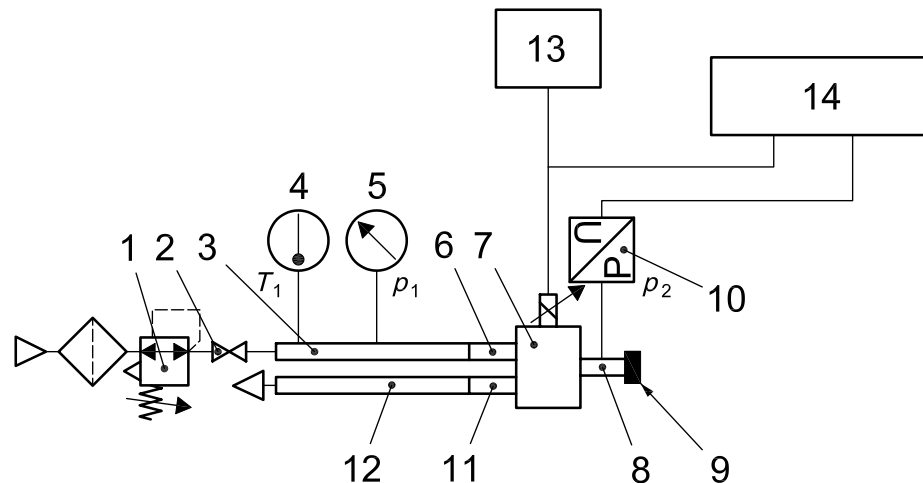

Key

- 1 supply pressure regulator
- 2 shut-off valve
- 3, 12 pressure-measuring tube
- 4 inlet temperature T_1 measuring-element
- 5 inlet pressure p_1 gauge or transducer
- 6, 11 transition connector
- 7 component under test
- 8 connector with pressure-measuring tap
- 9 plug
- 10 operating pressure p_2 gauge or transducer
- 13 signal generator
- 14 X-Y recorder

Figure 6 — Typical test circuit for determining pressure gain characteristic

9.3 Test procedure

9.3.1 Apply the inlet pressure chosen in 5.3.2, and maintain it within the tolerance specified in 5.3.1 during the test.

9.3.2 Using a signal generator to create a triangular signal that allows the full scale of the electrical control signal (-100% to $+100\%$) to be explored, record the electrical control signal on the X-axis and the operating pressure, p_2 , in the Y-axis of a X-Y recorder to obtain an hysteresis curve. In the case of a five-port valve, record operating pressure, p_4 , either simultaneously or successively.

9.3.3 The triangular electrical control signal shall evolve with a sufficiently low ramp speed so as to avoid any dynamic effects that might influence the operating pressure measurements: $0,5\%$ of full scale per second is the recommended ramp speed.

9.4 Characteristic curve of pressure gain at null operating flow rate

Plot on a graph the hysteresis curve(s) of operating pressure values versus the electrical control signal measured in 9.3 as shown in ISO 10041-1:2010, Figure 4.

10 Test to determine leakage at null operating flow rate characteristics

10.1 Test circuit

Figure 7 represents a typical test circuit for determining the leakage characteristic of a three-port continuous flow control valve at null operating flow rate. Figure 7 uses the upstream part of the test circuit for in-line test specified in ISO 6358-1, with the addition of the following requirements

- for a three-port valve, the connector for measuring operating pressure is plugged to guarantee a null operating flow rate. The length (volume) of this connector with pressure-measuring tap shall be as short (small) as possible. For a five-port valve, both such connectors are plugged, and
- the flowmeter is placed upstream in the supply line.

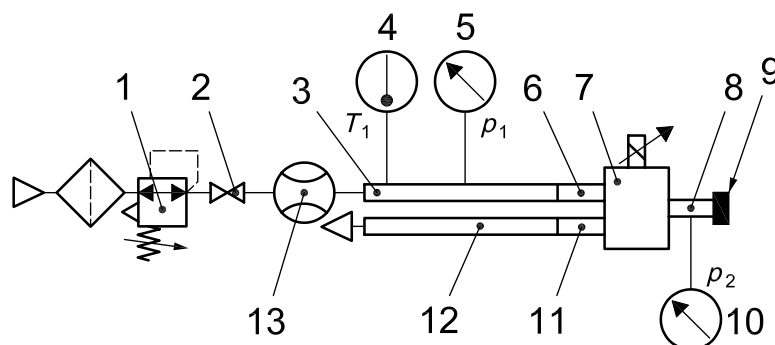

Key

- | | |
|-------|--|
| 1 | supply pressure regulator |
| 2 | shut-off valve |
| 3, 12 | pressure-measuring tube |
| 4 | inlet temperature T_1 measuring-element |
| 5 | inlet pressure p_1 gauge or transducer |
| 6, 11 | transition connector |
| 7 | component under test |
| 8 | connector with pressure-measuring tap |
| 9 | plug |
| 10 | operating pressure p_2 gauge or transducer |
| 13 | flow meter |

Figure 7 — Typical test circuit for determining leakage characteristics

10.2 Test procedure

10.2.1 Apply the inlet pressure, p_1 , chosen in 5.3.2, and maintain it within the tolerance specified in 5.3.1 during the test.

10.2.2 Increase the electrical control signal from its minimum to its maximum, and measure the leakage flow rate. Then decrease the electrical control signal from its maximum to its minimum and continue measuring the leakage flow rate, to obtain a hysteresis curve. Make additional measurements when the leakage variations are significant.

10.3 Calculation of characteristic

10.3.1 For each value of the electrical control signal, calculate the mean value of the two corresponding leakage flow rates measured in 10.2 while the electrical control signal was being, respectively, increased and decreased.

10.3.2 Report the largest calculated value as the inlet leakage at null operating flow rate characteristic.

11 Test to determine dynamic characteristics

11.1 Test installation

11.1.1 Figure 8 represents a typical test circuit for determining the dynamic characteristics of three-port valves. The test circuit for five-port control valves is similar, except that both working ports are at atmosphere. The test circuit for two-port control valves is the same, except that the component under test has any exhaust port.

11.1.2 The buffer tank used to limit fluctuations in inlet pressure shall be as close as possible to the inlet port of the valve under test.

11.1.3 The output signal is the position signal of the moving element of the valve under test. If the valve under test has an internal position sensor, that signal shall be used. Otherwise, it is necessary to add an external position sensor, but it shall be verified that the addition of such a sensor does not modify the dynamic characteristics of the valve under test.

11.1.4 Use an oscilloscope or other appropriate electronic equipment to record the time-dependent electrical control and position signals.

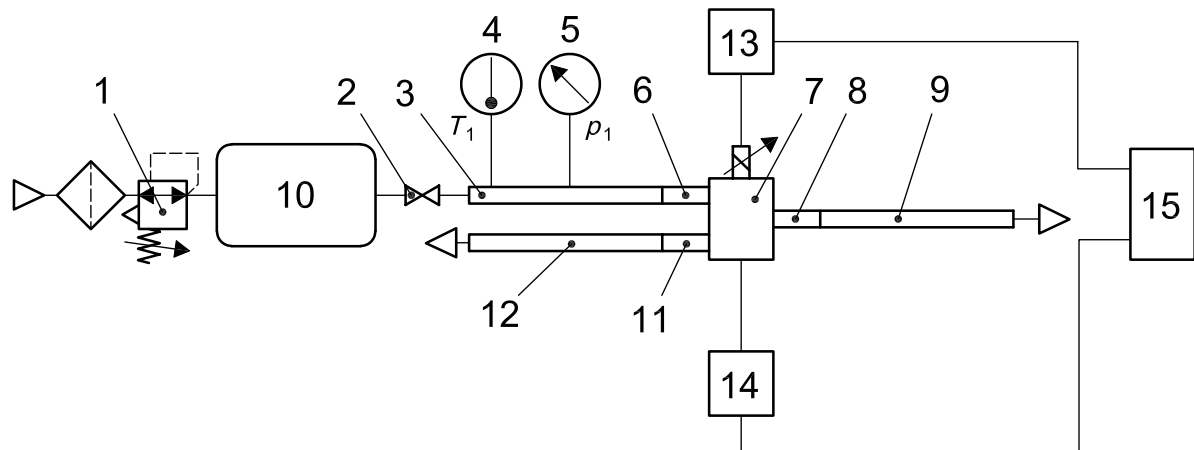

Key

- 1 supply pressure regulator
- 2 shut-off valve
- 3, 9, 12 pressure-measuring tube
- 4 sensor to measure inlet temperature T_1
- 5 pressure gauge or transducer to measure inlet pressure p_1
- 6, 8, 11 transition connector
- 7 valve under test
- 10 buffer tank
- 13 signal generator
- 14 position sensor
- 15 recorder

Figure 8 — Test circuit for determining dynamic characteristics

11.2 Test to determine frequency response

11.2.1 Test procedure

11.2.1.1 Install the valve under test as shown in Figure 8. Apply the inlet pressure p_1 chosen in 5.3.2, and maintain it within the tolerance specified in 5.3.1 during the test.

11.2.1.2 Apply a sinusoidal electrical control signal with an amplitude of 5 % centred on the median value of the electrical control signal (that is, varying between –5 % to +5 % on both sides of the median value) at a frequency of 5 Hz. Record the amplitude of the position signal and its phase lag versus the electrical control signal.

11.2.1.3 Progressively increase the frequency of the electrical control signal, while keeping its amplitude constant.

11.2.1.4 For each frequency, record the amplitude of the position signal and its phase lag versus the electrical control signal. Record specifically the frequency corresponding, respectively, to

- an attenuation of 3 dB (amplitude ratio equal to 0,7), and
- a phase lag of 90°.

11.2.1.5 Repeat 11.2.1.3 and 11.2.1.4 until an attenuation of 15 dB is reached (amplitude ratio equal to 0,18).

11.2.1.6 Repeat 11.2.1.3 to 11.2.1.5 for sinusoidal electrical control signals with amplitudes of 25 % and 90 %, centred on the median value of the electrical control signal, from a frequency of 5 Hz.

11.2.2 Frequency response characteristic curves

11.2.2.1 For each electrical control signal amplitude, plot on a graph the frequency response characteristic curves based on the results obtained in 11.2.1. For this purpose, perform the procedures specified in 11.2.2.2 and 11.2.2.3.

11.2.2.2 For each frequency, calculate, in decibels, the amplitude ratio of the position signal versus the control signal.

11.2.2.3 Report this amplitude ratio and the phase lag values in a graph, as a function of the frequency based on a logarithmic scale as shown in ISO 10041-1:2010, Figure 5.

11.2.2.4 Report these curves for different amplitudes on the same graph, as shown in ISO 10041-1:2010, Figure 5.

11.2.3 Characteristic frequencies

For each electrical control signal amplitude, report the frequency values, determined in accordance with 11.2.1.4 and corresponding, respectively, to an attenuation of 3 dB and a 90° phase lag, as shown in ISO 10041-1:2010, Table 4.

11.3 Test to determine step responses

11.3.1 Test procedure

11.3.1.1 Install the valve under test as shown in Figure 8. Apply the inlet pressure, p_1 , chosen in 5.3.2, and maintain it within the tolerance specified in 5.3.1 during the test.

11.3.1.2 For each of the three types of control steps and for each of the three steps specified in Table 2:

- Generate a positive electrical control signal step in accordance with the electrical control signal values specified in Table 2. Simultaneously record the change in the electrical control signal and the change in the measured position along the displacement of the valving element until the position stabilizes.
- Generate in the same manner a negative electrical control signal step in accordance with the electrical control signal values specified in Table 2. Simultaneously record the change in the electrical control signal and the change in the measured position along the displacement of the valving element until the position stabilizes.

Table 2 — Electrical control signal values for each type of control step

Electrical control signal values	Type of control steps					
	On both sides of the median value of the electrical control signal		From the median value of the electrical control signal		Towards the median value of the electrical control signal	
	Positive steps %	Negative steps %	Positive steps %	Negative steps %	Positive steps %	Negative steps %
Step 1	-5 to +5	+5 to -5	0 to +5	0 to -5	-5 to 0	+5 to 0
Step 2	-25 to +25	+25 to -25	0 to +25	0 to -25	-25 to 0	+25 to 0
Step 3	-90 to +90	+90 to -90	0 to +90	0 to -90	-90 to 0	+90 to 0

11.3.2 Characteristic curves

For each of the three types of control steps specified in Table 2, using the same time scale for the three steps

- plot in the same graph the time-dependent responses of the change in valving element position obtained in 11.3.1.2 for the three positive steps as shown in ISO 10041-1:2010, Figure 6,
- plot in another graph, the time-dependent responses of the change in valving element position obtained in 11.3.1.2 for the three negative steps as shown in ISO 10041-1:2010, Figure 7.

For this purpose, use, as a reference for the time scale, the time of the initiation of the electrical control signal step and plot in the graph the standardised valving element positions in percentage of their amplitudes.

11.3.3 Dynamic characteristic values

11.3.3.1 From the step responses curves obtained in 11.3.1.2, determine for each control step, the shifting time, the response time, the settling time and the overshoot as defined in Figure 9 for two cases of step response.

11.3.3.2 Report these values in the format given in ISO 10041-1:2010, Table 3.

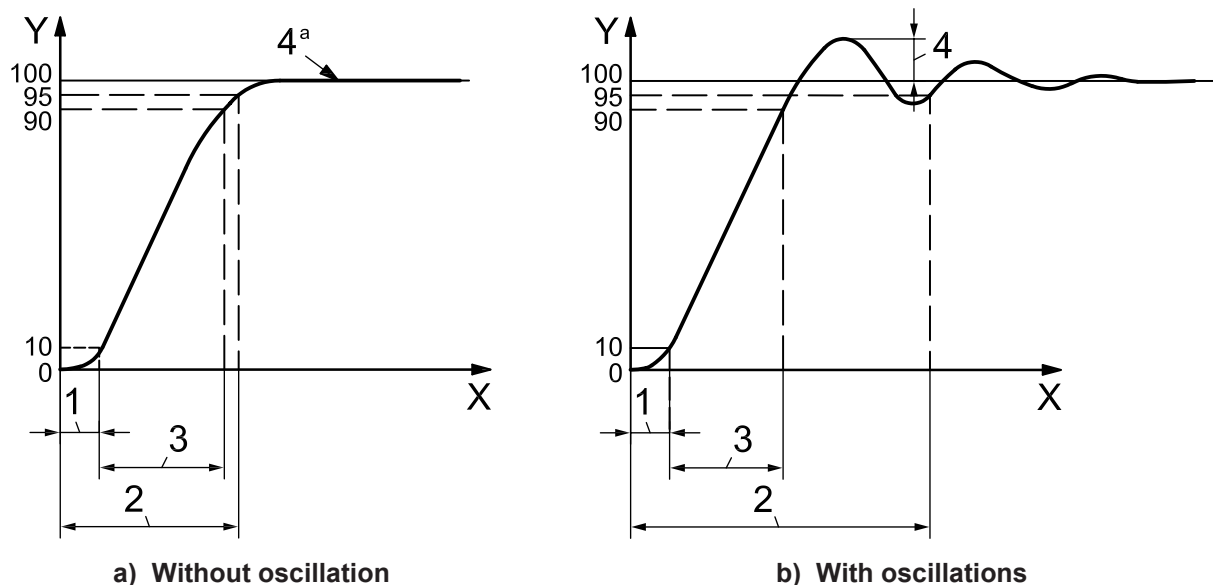

Key

- X time, in s
- Y position, in % of amplitude
- 1 shifting time
- 2 response time
- 3 settling time
- 4 overshoot, %
- ^a overshoot = 0 %

Figure 9 — Determination of dynamic characteristics from step response

12 Presentation of test results

12.1 General

Data from which the performance characteristics of an electro-pneumatic continuous flow control valve can be compared shall be presented as follows as described in 12.2 to 12.6.

12.2 Control signal-flow rate characteristics

The static control signal-flow rate characteristics determined in accordance with 7.3 shall be presented as follows:

- a data graph in accordance with ISO 10041-1:2010, Figure 1;
- the hysteresis value obtained in accordance with Equation (1) in 7.3.2;
- the resolution value obtained in accordance with 7.3.3;
- the repeatability value obtained in accordance with Equation (3) in 7.3.4.

12.3 Global flow rate characteristics

The global flow rate characteristics determined in accordance with 8.3 shall be presented as follows:

- for a two-port control valve:
 - forward flow rate characteristics for the maximum value of the electrical control signal determined in accordance with 8.3.1.1;
- for a three-port control valve:
 - forward flow rate characteristics for the maximum value of the electrical control signal determined in accordance with 8.3.1.1;
 - relief flow rate characteristics for the minimum value of the electrical control signal determined in accordance with 8.3.1.2;
- for a five-port control valve:
 - forward flow rate characteristics determined in accordance with 8.3.1.1, for the working port 2 for the maximum value of the electrical control signal and for the working port 4 for the minimum value of the electrical control signal;
 - relief flow rate characteristics determined in accordance with 8.3.1.2, for the working port 2 for the minimum value of the electrical control signal and for the working port 4 for the maximum value of the electrical control signal.

NOTE A data graph in accordance with ISO 10041-1:2010, Figure 2 a) (two-port valve) or Figure 2 b) (three-port valve) or Figure 3 (five-port valve) may also be given.

12.4 Pressure gain characteristics at null operating flow rate

Except for two-port control valves, the pressure gain characteristics at null operating flow rate determined in accordance with 9.4 shall be presented as follows:

- a data graph in accordance with ISO 10041-1:2010, Figure 4.

12.5 Leakage characteristic at null operating flow rate

Except for two-port control valves, the characteristic of the leakage at null operating flow rate determined in accordance with 10.2 shall be presented as follows:

- the maximum value of the leakage determined in accordance with 10.3.

12.6 Dynamic characteristics

The dynamic characteristics determined in accordance with Clause 11 shall be presented as follows:

- a graph of frequency responses curves in accordance with ISO 10041-1:2010, Figure 5;
- a table indicating the characteristic frequencies for different amplitudes in accordance with ISO 10041-1:2010, Table 3;
- two graphs of time-dependent curves of the change in valving element position during positive and negative electrical control signal steps for each of the three types of control steps defined in Table 2, in accordance with ISO 10041-1:2010, Figures 6 and 7;
- a table indicating the dynamic characteristic values in accordance with ISO 10041-1:2010, Table 3.

13 Identification statement (reference to this part of ISO 10041)

Use the following statement in test reports, catalogues and sales literature when complying with this part of ISO 10041:

“Main performance characteristics of electro-pneumatic continuous flow control valves determined in accordance with ISO 10041-2:2010, *Pneumatic fluid power — Electro-pneumatic continuous flow control valves — Part 2: Test methods to determine main characteristics to include in the supplier's literature.*”

Bibliography

- [1] ISO 2944, *Fluid power systems and components — Nominal pressures*
- [2] ISO 8778, *Pneumatic fluid power — Standard reference atmosphere*
- [3] ISO 10094-2, *Pneumatic fluid power — Electro-pneumatic pressure control valves — Part 2: Test methods to determine main characteristics to include in the supplier's literature*
- [4] ISO 11727, *Pneumatic fluid power — Identification of ports and control mechanisms of control valves and other components*

ICS 23.100.50

Price based on 25 pages

www.bsigroup.com

British Standards Institution (BSI)

BSI is the independent national body responsible for preparing British Standards and other standards-related publications, information and services.

It presents the UK view on standards in Europe and at the international level.

It is incorporated by Royal Charter.

Revisions

British Standards are updated by amendment or revision. Users of British Standards should make sure that they possess the latest amendments or editions.

It is the constant aim of BSI to improve the quality of our products and services. We would be grateful if anyone finding an inaccuracy or ambiguity while using this British Standard would inform the Secretary of the technical committee responsible, the identity of which can be found on the inside front cover.

Tel: +44 (0)20 8996 9001 Fax: +44 (0)20 8996 7001

BSI offers Members an individual updating service called PLUS which ensures that subscribers automatically receive the latest editions of standards.

Tel: +44 (0)20 8996 7669 Fax: +44 (0)20 8996 7001

Email: plus@bsigroup.com

Buying standards

You may buy PDF and hard copy versions of standards directly using a credit card from the BSI Shop on the website www.bsigroup.com/shop. In addition all orders for BSI, international and foreign standards publications can be addressed to BSI Customer Services.

Tel: +44 (0)20 8996 9001 Fax: +44 (0)20 8996 7001

Email: orders@bsigroup.com

In response to orders for international standards, it is BSI policy to supply the BSI implementation of those that have been published as British Standards, unless otherwise requested.

Information on standards

BSI provides a wide range of information on national, European and international standards through its Knowledge Centre.

Tel: +44 (0)20 8996 7004 Fax: +44 (0)20 8996 7005

Email: knowledgecentre@bsigroup.com

Various BSI electronic information services are also available which give details on all its products and services.

Tel: +44 (0)20 8996 7111 Fax: +44 (0)20 8996 7048

Email: info@bsigroup.com

BSI Subscribing Members are kept up to date with standards developments and receive substantial discounts on the purchase price of standards. For details of these and other benefits contact Membership Administration.

Tel: +44 (0)20 8996 7002 Fax: +44 (0)20 8996 7001

Email: membership@bsigroup.com

Information regarding online access to British Standards via British Standards Online can be found at www.bsigroup.com/BSOL

Further information about BSI is available on the BSI website at www.bsigroup.com/standards

Copyright

Copyright subsists in all BSI publications. BSI also holds the copyright, in the UK, of the publications of the international standardization bodies. Except as permitted under the Copyright, Designs and Patents Act 1988 no extract may be reproduced, stored in a retrieval system or transmitted in any form or by any means – electronic, photocopying, recording or otherwise – without prior written permission from BSI. This does not preclude the free use, in the course of implementing the standard of necessary details such as symbols, and size, type or grade designations. If these details are to be used for any other purpose than implementation then the prior written permission of BSI must be obtained. Details and advice can be obtained from the Copyright & Licensing Manager.

Tel: +44 (0)20 8996 7070

Email: copyright@bsigroup.com

BSI Group Headquarters

389 Chiswick High Road London W4 4AL UK

Tel +44 (0)20 8996 9001

Fax +44 (0)20 8996 7001

www.bsigroup.com/standards

raising standards worldwide[™]

Copyright British Standards Institution
Provided by IHS under license with BSI - Uncontrolled Copy
No reproduction or networking permitted without license from IHS

Not for Resale

