



BSI Standards Publication

**Cellular plastics —
Determination of horizontal
burning characteristics of small
specimens subjected to a small
flame**

National foreword

This British Standard is the UK implementation of ISO 9772:2012. It supersedes BS ISO 9772:2001 which is withdrawn.

The UK participation in its preparation was entrusted to Technical Committee PRI/26, Burning behaviour of plastics and rubbers.

A list of organizations represented on this committee can be obtained on request to its secretary.

This publication does not purport to include all the necessary provisions of a contract. Users are responsible for its correct application.

© The British Standards Institution 2012. Published by BSI Standards Limited 2012

ISBN 978 0 580 69761 6

ICS 13.220.40; 83.100

Compliance with a British Standard cannot confer immunity from legal obligations.

This British Standard was published under the authority of the Standards Policy and Strategy Committee on 31 October 2012.

Amendments issued since publication

| Date | Text affected |
|------|---------------|
|------|---------------|

**Cellular plastics — Determination of
horizontal burning characteristics of small
specimens subjected to a small flame**

*Plastiques alvéolaires — Détermination des caractéristiques de
combustion de petites éprouvettes en position horizontale, soumises à
une petite flamme*





COPYRIGHT PROTECTED DOCUMENT

© ISO 2012

All rights reserved. Unless otherwise specified, no part of this publication may be reproduced or utilized in any form or by any means, electronic or mechanical, including photocopying and microfilm, without permission in writing from either ISO at the address below or ISO's member body in the country of the requester.

ISO copyright office
Case postale 56 • CH-1211 Geneva 20
Tel. + 41 22 749 01 11
Fax + 41 22 749 09 47
E-mail copyright@iso.org
Web www.iso.org

Published in Switzerland

Contents

Page

| | |
|--|-----------|
| Foreword | iv |
| Introduction | v |
| 1 Scope | 1 |
| 2 Normative references | 1 |
| 3 Terms and definitions | 1 |
| 4 Significance of test | 2 |
| 5 Apparatus | 2 |
| 6 Specimens | 7 |
| 6.1 Extended application of test results | 7 |
| 6.2 Preparation of specimens | 8 |
| 7 Conditioning | 8 |
| 7.1 Specimens | 8 |
| 7.2 Cotton indicator | 9 |
| 8 Test procedure | 9 |
| 8.1 Adjustment of flame | 9 |
| 8.2 Adjustment of specimen support | 10 |
| 8.3 Positioning of cotton indicator | 11 |
| 8.4 Positioning of specimen | 11 |
| 8.5 Burning procedure | 11 |
| 8.6 Measurements | 11 |
| 8.7 Preparation for the next test | 12 |
| 9 Calculations | 12 |
| 10 Precision | 12 |
| 11 Test report | 12 |
| Annex A (informative) Classification system | 14 |
| Annex B (informative) Precision | 16 |
| Bibliography | 17 |

Foreword

ISO (the International Organization for Standardization) is a worldwide federation of national standards bodies (ISO member bodies). The work of preparing International Standards is normally carried out through ISO technical committees. Each member body interested in a subject for which a technical committee has been established has the right to be represented on that committee. International organizations, governmental and non-governmental, in liaison with ISO, also take part in the work. ISO collaborates closely with the International Electrotechnical Commission (IEC) on all matters of electrotechnical standardization.

International Standards are drafted in accordance with the rules given in the ISO/IEC Directives, Part 2.

The main task of technical committees is to prepare International Standards. Draft International Standards adopted by the technical committees are circulated to the member bodies for voting. Publication as an International Standard requires approval by at least 75 % of the member bodies casting a vote.

Attention is drawn to the possibility that some of the elements of this document may be the subject of patent rights. ISO shall not be held responsible for identifying any or all such patent rights.

ISO 9772 was prepared by Technical Committee ISO/TC 61, *Plastics*, Subcommittee SC 4, *Burning behaviour*.

This third edition cancels and replaces the second edition (ISO 9772:2001), which has been technically revised. It also incorporates the Amendment ISO 9772:2001/Amd.1:2003.

Introduction

Cellular plastics are widely used in products for packaging, building, housing, industry and transport, in various applications. The burning behaviour of cellular plastics is a concern for the fire safety of these products. This International Standard gives a method for the determination of the burning behaviour of cellular plastics using a small flame source.

The burning behaviour of cellular plastics is influenced by the test specimen orientation (vertical or horizontal). This method of test evaluates specimens which are oriented horizontally.

The method described is also intended as a pre-selection test for materials used for components of devices and appliances. The final acceptance of the material would be dependent upon its use in complete equipment that conforms with the standards applicable to such equipment.

It should be noted that the test results obtained by the test specified in this International Standard alone cannot represent all the aspects of the fire hazard of cellular plastics in end-use conditions.

Cellular plastics — Determination of horizontal burning characteristics of small specimens subjected to a small flame

1 Scope

1.1 This International Standard specifies a small-scale laboratory screening procedure for comparing the relative burning characteristics of horizontally oriented, small cellular plastic specimens having a density less than $250 \text{ kg}\cdot\text{m}^{-3}$ determined in accordance with ISO 845, when exposed to a small-flame ignition source.

NOTE Another International Standard exists covering flexible cellular plastic and cellular rubber: ISO 3582^[2].

1.2 This method of test is intended for quality assurance and limited product evaluation of cellular plastic materials under controlled laboratory conditions, and is not intended to assess the fire behaviour of e.g. building materials or furnishings under actual fire conditions.

1.3 The optional classification system described in Annex A is intended for the pre-selection of cellular plastic materials for products, including the determination of the ranges of material parameters that give the same classification (see 6.1).

2 Normative references

The following referenced documents are indispensable for the application of this document. For dated references, only the edition cited applies. For undated references, the latest edition of the referenced document (including any amendments) applies.

ISO 845, *Cellular plastics and rubbers — Determination of apparent density*

ISO 1923, *Cellular plastics and rubbers — Determination of linear dimensions*

ISO 10093, *Plastics — Fire tests — Standard ignition sources*

ISO 13943, *Fire safety — Vocabulary*

3 Terms and definitions

For the purposes of this International Standard, the terms and definitions given in ISO 13943 and the following apply.

3.1

afterflame time

length of time for which a material continues to flame, under specified test conditions, after the ignition source has been removed

3.2

afterglow time

length of time for which a material continues to glow, under specified test conditions, after the ignition source has been removed and/or extinguishment of flame

3.3

extended application of test results

process of predicting a test result, on the basis of one or more existing test results obtained by the same test, for a product for which a property and/or the intended end-use application(s) are subject to variation

4 Significance of test

4.1 Tests conducted on a material under the conditions specified can be of considerable value when comparing the horizontal burning characteristics of different materials, controlling manufacturing processes or assessing any changes in formulation or treatment prior to use.

4.2 Assessment of fire hazard requires consideration of factors such as fuel contribution, intensity of burning (rate of heat release) and products of combustion, as well as environmental factors such as intensity of source, orientation of exposed material and ventilation conditions.

4.3 Horizontal burning characteristics, as measured by this test procedure, might be affected by factors such as density, any anisotropy of the cellular material, its melting characteristics, its colour and its thickness.

4.4 Certain materials might shrink from the applied flame without igniting. In this event, the test results are not valid, and additional test specimens will be required to obtain 10 valid test results. If this proves impossible due to non-ignition of all the specimens, then this test is not suitable for these materials.

4.5 The horizontal burning characteristics of some cellular plastic materials might change with time, and tests are therefore conducted before and after heat ageing.

5 Apparatus

5.1 Laboratory fume hood, having an inside volume of at least 0,5 m³. The chamber shall permit observation of tests in progress and shall be draught free whilst allowing normal thermal circulation of air past the test specimen during burning. The inside surfaces of the chamber shall be of a dark colour. When a light meter, facing towards the rear of the chamber, is positioned in place of the test specimen, the recorded light level shall be less than 20 lux.

For safety and convenience, this enclosure (which can be completely closed) shall be fitted with an extraction device, such as an exhaust fan, to remove products of combustion that might be toxic. The extraction device shall be turned off during the test and turned on again immediately after the test to remove the fire effluents. A positive closing damper might be needed.

NOTE The amount of oxygen available to support combustion is naturally important for the conduct of these flame tests. For tests conducted by this method when burning times are protracted, chamber sizes greater than 0,5 m³ might be needed to provide reproducible results.

5.2 P/PF2 laboratory burner, as specified in ISO 10093, having a barrel length of (100 ± 10) mm and an internal diameter of (9,5 ± 0,3) mm. The barrel shall not be equipped with an end attachment, such as a stabilizer.

5.3 Burner wing top, having an opening of internal length (48 ± 1) mm and internal width (1,3 ± 0,05) mm (see Figure 1).

To ensure the wing top opening is uniform in width, a (1,3 ± 0,05) mm steel wire or spacer may be slid along its length.

5.4 Support gauze, approximately 215 mm long by 75 mm wide, having 13 mm of its length bent to form a right angle at one end as shown in Figure 2. It shall consist of (6,4 ± 0,5) mm mesh gauze constructed of (0,85 ± 0,10) mm diameter stainless steel or low carbon steel wire. A different support gauze is necessary for each specimen unless means are provided to burn off any residue from a prior test.

5.5 Support-gauze holder, consisting of two laboratory ring stands with clamps adjustable to the desired angles and heights. The support-gauze holder shall be constructed from aluminium or steel and shall satisfy the following conditions:

— the long axis of the gauze is maintained to within 1° of the horizontal;

- the nearest end of the specimen is (13 ± 1) mm above the burner wing top (see Figures 3 and 4);
- the space both above and below the specimen is not obstructed;
- a means is provided for positioning the burner in the correct location relative to the specimen, preferably with a sliding mechanism and a stop to allow fast movement of the burner flame towards and away from the specimen;
- the gauze is equidistant from the front and back, and from both sides, of the test chamber, and is (175 ± 25) mm above the cotton indicator base-board (see Figure 3).

5.6 Two timing devices, which can be read to within 1 s or less.

5.7 Measuring scale, graduated in millimetres, to measure the length, width and thickness of the test specimen.

5.8 Gas supply, supplying technical-grade methane gas with a purity of at least 98 % and having a heat content of (37 ± 1) MJ·m⁻³, with regulator and meter to ensure uniform gas flow.

Other gas mixtures having a heat content of approximately (37 ± 1) MJ·m⁻³ or propane having a heat content of (94 ± 2) MJ·m⁻³ have been shown to provide similar results when using the procedure of Clause 8. In cases of dispute, however, technical-grade methane shall be used.

5.9 Manometer and gas flow meter, calibrated for the gas used and capable of reading the values shown in Table 1.

5.10 Cotton indicator, consisting of a pad of dry, absorbent 100 % cotton measuring approximately 150 mm long, 75 mm wide and 6 mm thick and having a mass of approximately 0,16 g.

5.11 Desiccator, containing anhydrous calcium chloride or another drying agent which can be maintained at (23 ± 2) °C and gives a relative humidity not exceeding 20 %.

5.12 Conditioning room or chamber, capable of being maintained at (23 ± 2) °C and a relative humidity of (50 ± 5) %.

5.13 Air-circulating oven, giving a minimum of five air-changes per hour, and capable of being maintained at (70 ± 2) °C or another agreed temperature.

5.14 Dial-gauge micrometer, for measuring the specimen thickness, with a 650 mm² pressure foot exerting a pressure of $(0,175 \pm 0,035)$ kPa.

5.15 Cotton indicator base-board, measuring approximately 215 mm long and 75 mm wide and having a height such that the distance between the support gauze and the top of the base-board is (175 ± 25) mm.

The cotton indicator base-board shall be made of non-combustible board having a dry density of (850 ± 200) kg·m⁻³. It shall not be made of metal.

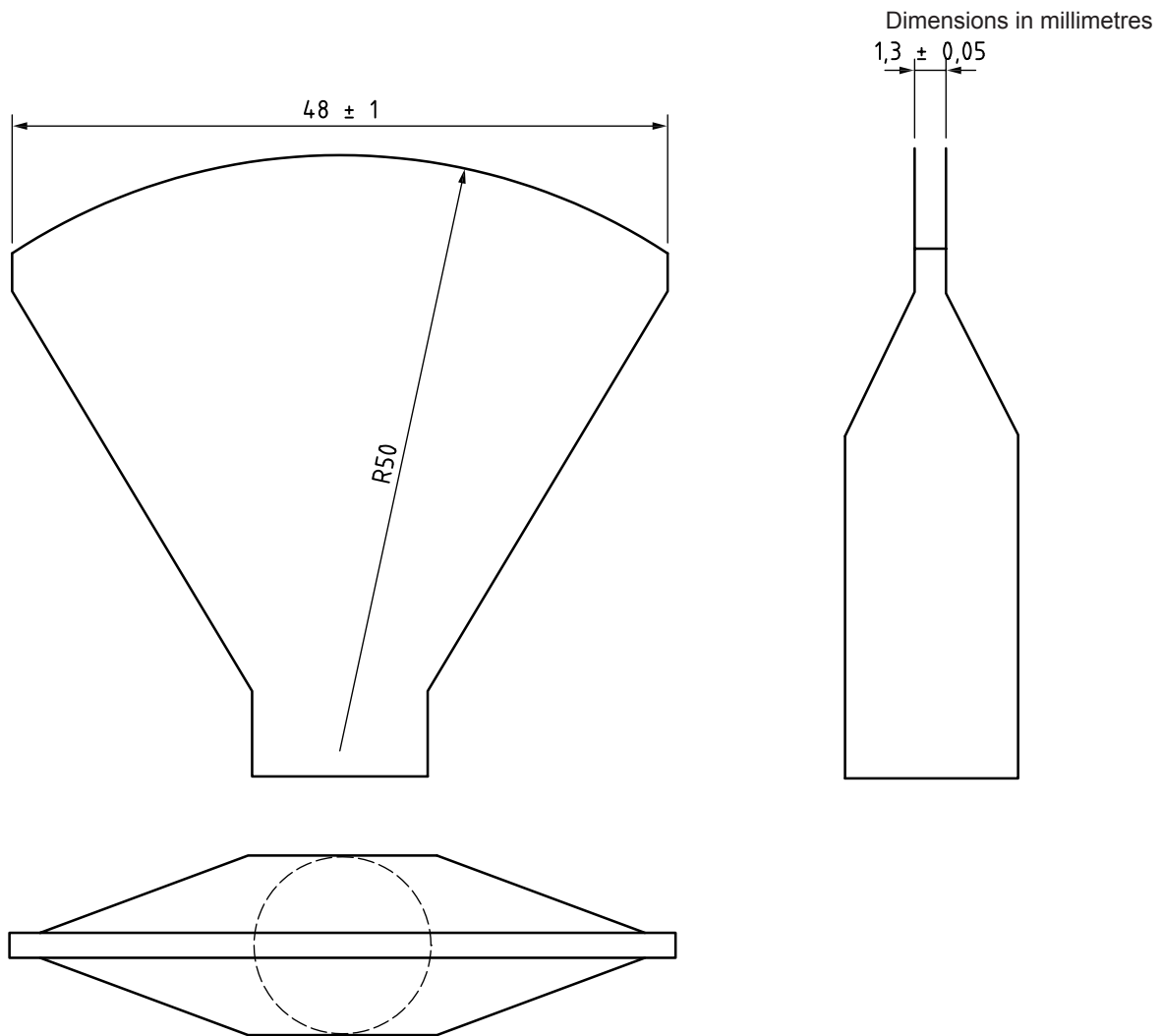

Material: copper or stainless steel

Figure 1 — Burner wing top

Dimensions in millimetres

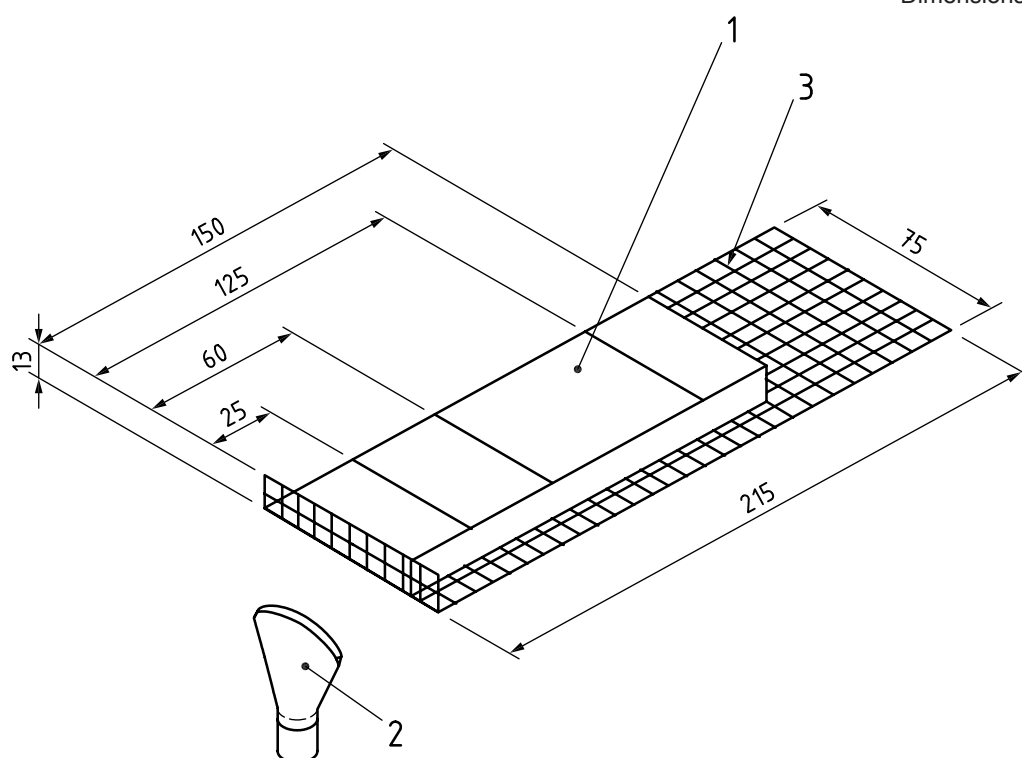

Key

- 1 test specimen
- 2 burner wing top
- 3 support gauze

Figure 2 — Test specimen and support gauze

Dimensions in millimetres

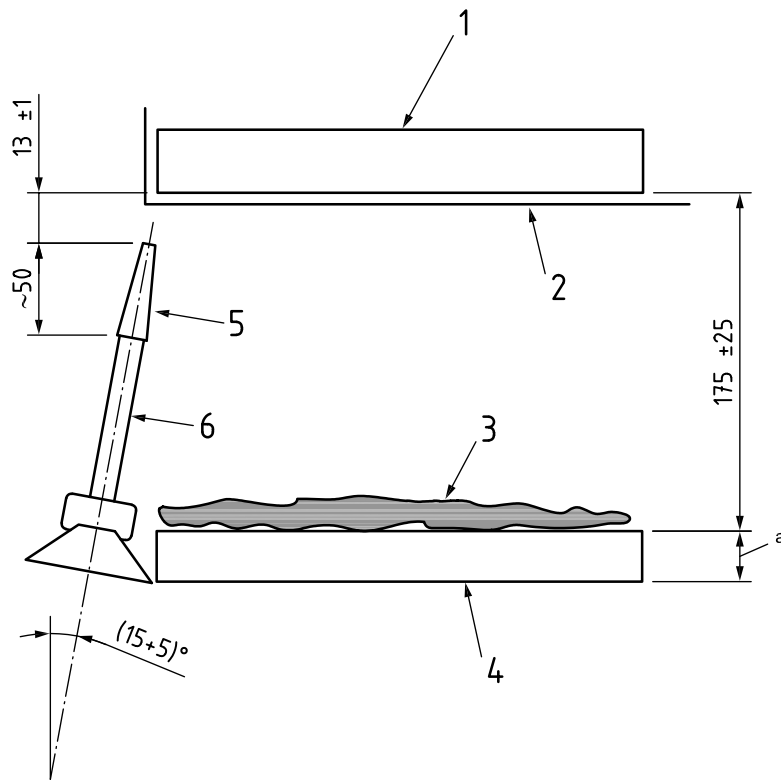

Key

- 1 test specimen
- 2 support gauze
- 3 cotton indicator
- 4 cotton indicator base-board
- 5 burner wing top
- 6 burner

^a Height of cotton indicator base-board.

Figure 3 — Position of cotton indicator below support gauze

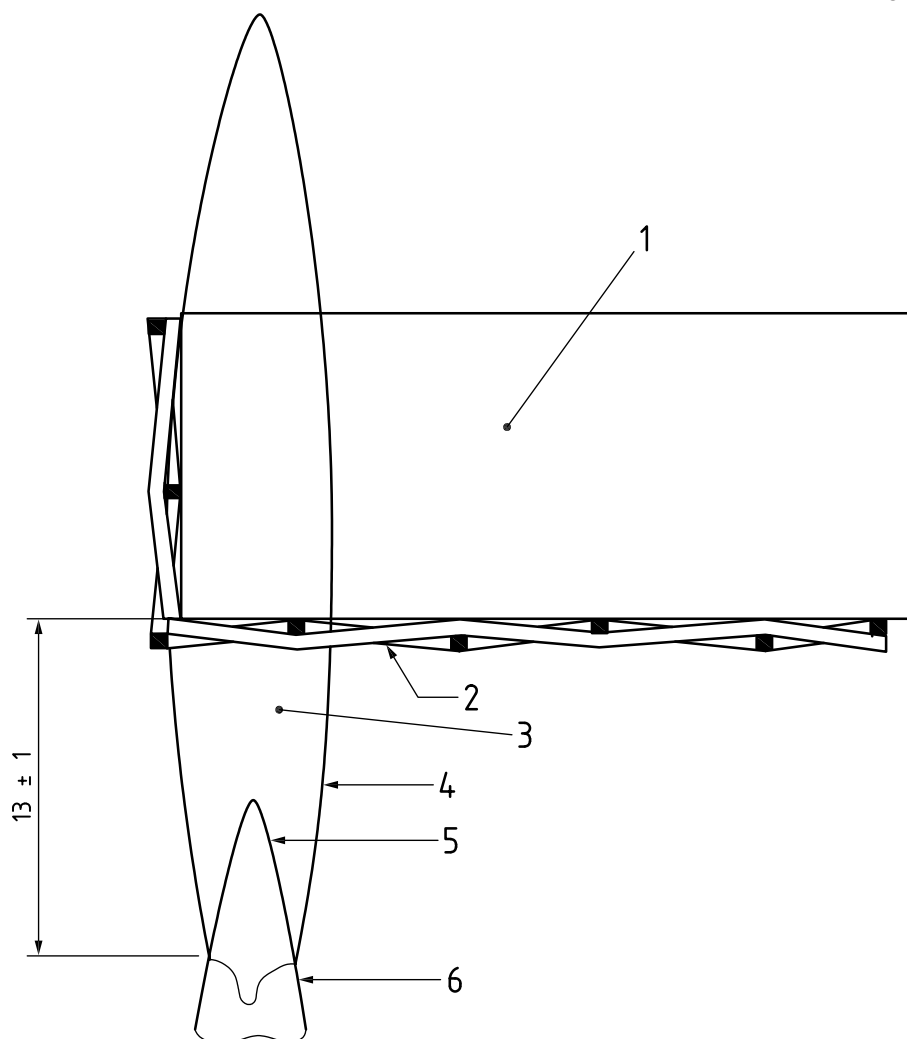

Key

- 1 test specimen, maximum thickness 13 mm
- 2 specimen support gauze, $(6,4 \pm 0,5)$ mm mesh
- 3 blue flame
- 4 profile of visible flame, 38 mm high
- 5 profile of inner cone of flame
- 6 burner wing top

Figure 4 — Details of flame and relative positions of burner wing top, test specimen and specimen support gauze

6 Specimens

6.1 Extended application of test results

6.1.1 It is possible that the results of tests carried out on specimens taken from materials of the same polymer composition but of different densities, colours and thicknesses will be different. For materials of the same polymer composition with properties which vary over a range, the specimens shall be representative of the whole range.

6.1.2 Test specimens with densities at the extremes of the range shall be tested and, if the test results yield the same flame test classification, all specimens within the range shall be considered representative of the range.

If the burning characteristics are not essentially the same, the results of the evaluation shall be considered to apply only to materials with the densities tested. Additional test specimens with intermediate densities shall be tested to determine the range of applicability.

6.1.3 Uncoloured test specimens and test specimens with the highest level of organic and inorganic pigment loading shall be tested and, if the test results yield the same flame test classification, all specimens within this colour range shall be considered representative of the range. If the burning characteristics are not essentially the same, the results of the evaluation shall be considered to apply only to materials with the pigment loadings tested. If a material contains pigments which are known to affect the flammability characteristics, specimens containing these pigments shall also be tested. Thus the test specimens tested shall be those that

- a) contain no colouring;
- b) contain the highest level of organic pigments;
- c) contain the highest level of inorganic pigments;
- d) contain pigments which are known to adversely affect the flammability characteristics.

6.2 Preparation of specimens

6.2.1 All specimens shall be cut from a representative sample of the material (sheets or end products). After any cutting operation, care shall be taken to remove all dust and any particles from the surface. Cut edges shall have a smooth finish.

6.2.2 The standard test specimen shall be (150 ± 10) mm long by (50 ± 1) mm wide. Materials supplied in thicknesses over 13 mm shall be cut to (13 ± 1) mm thickness with any skin on one side. Materials supplied in thicknesses of 13 mm or less shall be tested at the thickness supplied, without removing any skin (see 6.2.5). If materials with adhesive applied are to be tested, specimens having adhesive on one side only shall be used (see 6.2.5).

NOTE Tests made on test specimens taken from the same material but of different thicknesses or directions of anisotropy are not comparable.

6.2.3 Prepare a minimum of 20 specimens for the test. This includes 10 additional specimens in the event that the situation described in 4.4, 4.5 or Clause A.3 is encountered.

6.2.4 Mark each specimen across its width with lines at 25 mm, 60 mm and 125 mm from one end, referred to hereafter as gauge marks (see Figure 2).

6.2.5 Test specimens with a high-density exterior (skin) on one side shall be tested with this side facing down. Test specimens with adhesive on one side shall be tested with this side facing up.

7 Conditioning

7.1 Specimens

7.1.1 The specimens shall not be conditioned until at least 24 h after their fabrication.

7.1.2 Condition two sets of five specimens for at least 48 h at (23 ± 2) °C and (50 ± 5) % relative humidity. One set is for possible retests as described in 4.4, 4.5 or Clause A.3.

7.1.3 Condition two sets of five specimens for (168 ± 2) h at (70 ± 2) °C and then place in a desiccator (5.11) for at least 4 h to cool to room temperature. One set is for possible retests as described in 4.4, 4.5 or Clause A.3.

Other heat-ageing times and temperatures may be used if agreeable to all parties.

7.1.4 All test specimens shall be tested in laboratory atmospheres of 15 °C to 35 °C and 45 % to 75 % relative humidity.

7.2 Cotton indicator

Condition an adequate supply of cotton indicator (5.10) in a desiccator (5.11) for at least 48 h prior to use.

8 Test procedure

8.1 Adjustment of flame

8.1.1 Ensure that the fume hood fan is off.

8.1.2 Adjust the gas flow rate and line pressure to the values shown in Table 1 for the gas supply (5.8), using the arrangement shown in Figure 5. In a position remote from the specimen support, adjust the burner (5.2) with its wing top (5.3) attached to provide a blue flame (38 ± 2) mm high when measured in subdued light. The flame is obtained by adjusting the gas flow rate and the air port of the burner until a (38 ± 2) mm high yellow-tipped blue flame is produced and then increasing the air supply until the yellow tip just disappears. Measure the height of the flame again and, if necessary, readjust.

When using propane, adjust the gas flow rate and line pressure to the values shown in Table 1. The flame will have a yellow tip.

NOTE A flame that is not uniform and has higher ends might be caused by a wing top opening that is not spaced properly (see 5.3, second paragraph).

Table 1 — Gas sources

| Gas | Approximate heat content MJ/m ³ | Flow rate ml/min | Line back-pressure ^a mm H ₂ O column |
|----------------------|---|---------------------|---|
| Methane ^b | 37 ± 1 | 965 ± 30 | 50 ± 10 |
| Propane | 94 ± 2 | 380 ± 15 | 25 ± 5 |

^a The needle valve of the burner shall be adjusted to provide the line back-pressure indicated.

^b Natural gas having a heat content of (37 ± 1) MJ/m³ has been found to produce similar results.

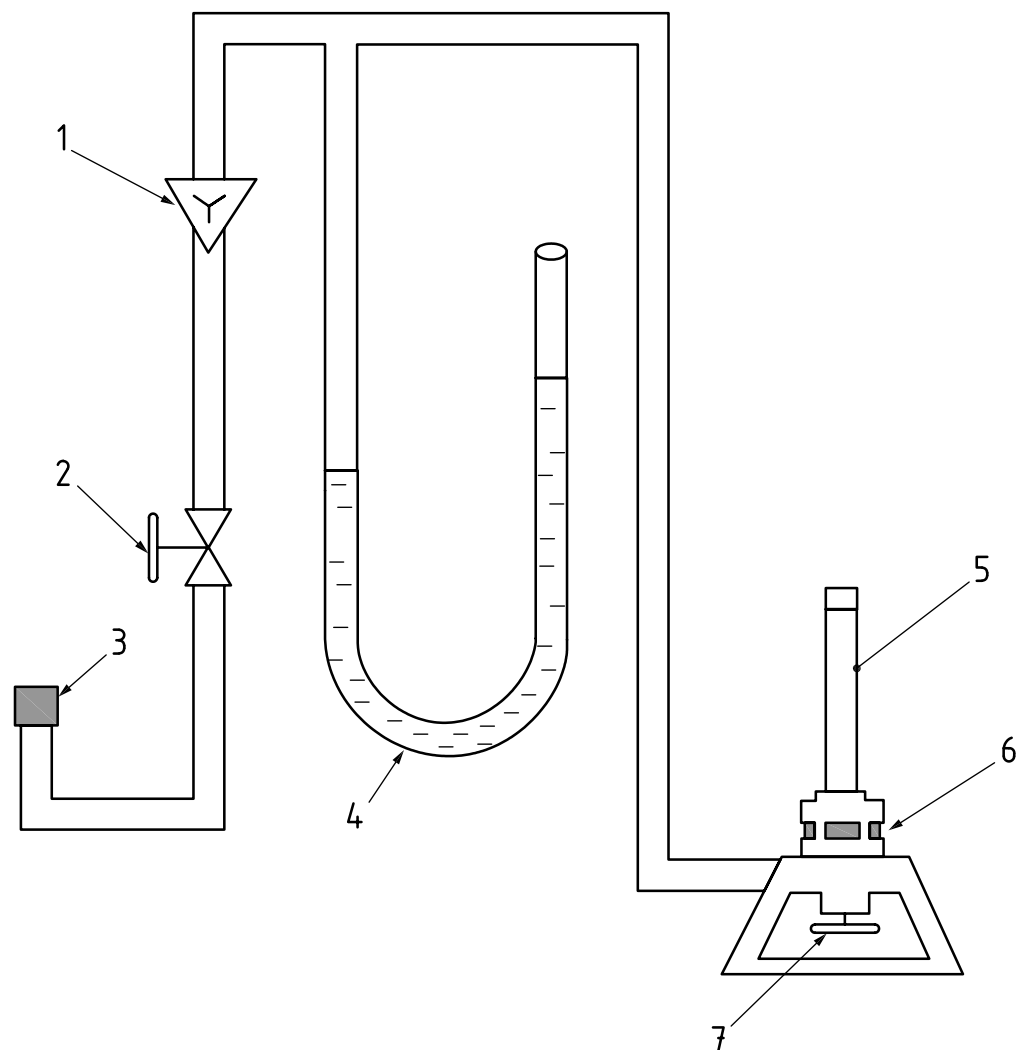

- Key**
- 1 flow meter
 - 2 control valve
 - 3 fuel-gas source
 - 4 manometer
 - 5 burner
 - 6 adjustable air inlet
 - 7 needle valve adjustment

Figure 5 — Burner supply arrangement

8.2 Adjustment of specimen support

Place a clean specimen support gauze in the holder in such a way that the lower surface of the test specimen will be (13 ± 1) mm above the tip of the burner wing top as shown in Figure 4. The relative positions of burner and holder shall be such that, when the test specimen is in position, one edge of the flame will extend in to the test specimen as shown in Figure 4. The centre of the wing top shall be directly under the longitudinal axis of the test specimen.

8.3 Positioning of cotton indicator

Remove sufficient cotton indicator (5.10) from the desiccator (5.11) and thin to an area approximately 150 mm × 75 mm and maximum uncompressed thickness of 6 mm. Position the cotton under the support gauze as shown in Figure 3.

8.4 Positioning of specimen

Place a test specimen on the support gauze in such a manner that:

- the surface on which the gauge marks have been made is uppermost;
- the end nearest to the 60 mm gauge mark is touching the 13 mm upturned portion of the support gauze;
- its longitudinal axis is parallel to, and vertically above, that of the support gauze.

8.5 Burning procedure

8.5.1 Place the burner quickly in position under the upturned end of the specimen support and simultaneously start the first timing device (see 5.6). The burner may be inclined at $(15 \pm 5)^\circ$ to the vertical in order to avoid debris falling from the specimen dropping on to the burner.

8.5.2 Immediately close the front panel of the fume hood, if not already closed, so that there is only a small air gap, e.g. height (50 ± 10) mm, along the base of the panel.

8.5.3 After 60 s, remove the burner a distance of 100 mm or greater from the specimen.

8.5.4 Start the second timing device when the test specimen flame reaches the 25 mm gauge mark, whether the burning is on the bottom, top or edge of the specimen.

8.5.5 Stop the first timing device when the flame or glowing combustion front reaches the 60 mm gauge mark, or when the specimen ceases to burn or glow before reaching the 60 mm gauge mark.

8.5.6 Stop the second timing device when the flame or glowing combustion front reaches the 125 mm gauge mark, or when the specimen ceases to burn before reaching the 125 mm gauge mark.

8.5.7 Observe whether the cotton indicator was ignited by flaming drips.

8.5.8 Ignore drips falling into the burner unless a visible change occurs in the flame. In this case, abandon the test on this specimen and, after cleaning the burner and wing top, substitute a new test specimen.

8.5.9 Switch on the fume-hood fan and, after exhausting all fumes, remove the test specimen and the support gauze.

8.6 Measurements

8.6.1 Distance burnt (L_d): This is the distance between the 25 mm gauge mark and the point where the flame or glowing combustion front stopped, expressed in millimetres. If the flame front went out before the 25 mm mark, record that $L_d = 0$.

8.6.2 Burning time (t_b): This is the time measured by the second timing device, in seconds, from when the flame or glowing combustion front passed the 25 mm gauge mark, until the flame front stopped or passed the 125 mm gauge mark.

8.6.3 Elapsed time (t_e): This is the time measured by the first timing device if the flame or glowing combustion front did not pass the 60 mm gauge mark, recorded as the time, in seconds, that the specimen continued to flame or to glow after the 60 s flame application. This is a combination of the afterflame time and afterglow time.

NOTE When using the classification system indicated in Annex A, the afterflame time and afterglow time need to be recorded individually by the first timing device.

8.7 Preparation for the next test

8.7.1 If reusing the support gauze, burn and clean off any residues remaining and allow it to cool to room temperature before reuse.

8.7.2 Examine the burner and wing top for cleanliness and clean if necessary.

8.7.3 Check the flame (see 8.1.2) at least once every five tests.

8.7.4 Switch off the fume-hood exhaust fan and repeat the procedure in 8.2 to 8.5 for the next test specimen.

9 Calculations

9.1 If the flame or glowing combustion front passed the 125 mm gauge mark, calculate the burning rate v , expressed in millimetres per minute, from the equation:

$$v = \frac{6\,000}{t_b}$$

where t_b is the burning time, in seconds.

9.2 If the flame or glowing combustion front did not pass the 125 mm gauge mark but did pass the 60 mm gauge mark, calculate the burning rate v , expressed in millimetres per minute, from the equation:

$$v = \frac{60L_d}{t_b}$$

where

L_d is the distance burnt, in millimetres;

t_b is the burning time, in seconds.

9.3 Calculate and record the average of five specimens for each conditioning treatment.

10 Precision

See Annex B.

11 Test report

The test report shall include the following particulars:

- a reference to this International Standard;
- a complete identification of the material tested, including the manufacturer's name, number or code;
- the nominal apparent density;

- d) the thickness, determined by ISO 1923, to the nearest millimetre, of the test specimen;
- e) the presence or absence of skins;
- f) the presence or absence of adhesive;
- g) the direction of any anisotropy relative to the test specimen dimensions;
- h) the conditioning treatment used (see 7.1.2 and 7.1.3);
- i) details of any treatment prior to testing, other than cutting, trimming and conditioning;
- j) the individual test values, including:
 - distance burnt (L_d),
 - burning time (t_b),
 - elapsed time (t_e),
 - afterflame time (for Annex A only),
 - afterglow time (for Annex A only),
 - burning rate (ν) (also for the HBF classification in Annex A),
 - whether the cotton indicator was ignited,
 - the gas used, if different from methane,
 - details of any abnormal burning behaviour;
- k) the performance class of the product, if required, in accordance with Annex A.

Annex A (informative)

Classification system

A.1 General

This annex describes a classification system that is used to characterize the burning behaviour of cellular plastic materials having densities less than $250 \text{ kg}\cdot\text{m}^{-3}$, tested in a horizontal position. The use of the classification is optional, and the class is determined by examining the test results for materials tested by the method of this International Standard. Each class represents a range of performance levels that simplifies description in material designations or specifications and could assist certification bodies to determine compliance with applicable requirements.

A.2 Classification

Select the one class that best matches the material's performance according to the requirements of Table A.1. Optionally, record the classification in the test report.

Table A.1 — Class designations

| Material performance | Class | | |
|---|--|--|-----------|
| | HF-1 | HF-2 | HBF |
| Linear burning rate, v (mm/min) | NA | NA | 40 |
| Afterflame time for each individual specimen, s | 4 out of 5 are ≤ 2 1 out of 5 is ≤ 10 | 4 out of 5 are ≤ 2 1 out of 5 is ≤ 10 | NA |
| Afterglow time for each individual specimen, s | ≤ 30 | ≤ 30 | NA |
| Cotton ignited by flaming particles or drops? | No | Yes | NA |
| Damaged length ($L_d + 25 \text{ mm}$) for each individual specimen | ≤ 60 | ≤ 60 | ≥ 60 |
| NA = Not applicable. | | | |

A.3 Materials of classes HF-1 and HF-2

If a set of five specimens does not conform to the requirements in Table A.1 for class HF-1 or HF-2 because of one of the following situations:

- a) a single specimen flames for more than 10 s or
- b) two specimens flame for more than 2 s but less than 10 s or
- c) one specimen flames for more than 2 s but less than 10 s, and a second specimen flames for more than 10 s or
- d) one specimen does not conform to any of the other criteria in Table A.1,

test another set of five specimens subjected to the same conditioning.

Classify the material as HF-1 or HF-2 for that thickness and density only if all specimens from this second set conform to the requirements for the class in Table A.1.

A.4 Materials of class HBF

If only one specimen from a set of five specimens does not conform to the requirements of Table A.1 for class HBF, test another set of five specimens subjected to the same conditioning.

Classify the material as HBF for that thickness and density only if all specimens from this second set conform to the requirements for the class in Table A.1.

Annex B (informative)

Precision

B.1 Data

The precision data were determined from an inter-laboratory trial conducted in 1986 involving seven laboratories, five materials (levels) and two replicates each using the average of five data points. The results were analysed using ISO 5725:1986^[3].

B.2 Repeatability

In the normal and correct operation of the method, the difference between two averages (determined from five specimens) obtained using identical test material and the same apparatus by one operator within a short time interval will not exceed the repeatability value shown in Table B.1 more than once in 20 cases on average.

B.3 Reproducibility

In the normal and correct operation of the method, the difference between two independent averages (determined from five specimens) found by two operators working in different laboratories on identical test material will not exceed the reproducibility value shown in Table B.1 more than once in 20 cases on average.

Table B.1 — Precision data

| Factor | Elapsed time s | | Rate of burning mm/min | | |
|-----------------|------------------------|-----|---------------------------|--------------|-------------|
| | Flame-retardant PUR | PIR | Flexible PUR foam | PS beadboard | Extruded PS |
| Average | 22,2 | 0,1 | 105,2 | 257,7 | 97,4 |
| Repeatability | 16,4 | 0,7 | 15,3 | 53,3 | 28,3 |
| Reproducibility | 24,2 | 0,8 | 31,9 | 59,9 | 28,3 |

NOTE For materials symbols, see ISO 1043-1^[1].

B.4 Averages

The two averages (determined from five specimens) are to be considered suspect and not equivalent if they differ by more than the repeatability and reproducibility shown in Table B.1. Any judgement made on the basis of Clause B.2 or Clause B.3 would have an approximately 95 % (0,95) probability of being correct.

Note that Table B.1 is only intended to present a meaningful way of considering the approximate precision of this test method for a range of materials. These data should not be rigorously applied to acceptance or rejection of material, as they are specific to the inter-laboratory test and might not be representative of other lots, conditions, thicknesses or materials.

The tests in the inter-laboratory trial were carried out using a flame height of (38 ± 2) mm without measurement of the flow rate or the line back-pressure. The flow rates and back-pressure were specified at a later date with a view to improving the precision. However, the effect has not yet been quantified.

Bibliography

- [1] ISO 1043-1, *Plastics — Symbols and abbreviated terms — Part 1: Basic polymers and their special characteristics*
- [2] ISO 3582, *Flexible cellular polymeric materials — Laboratory assessment of horizontal burning characteristics of small specimens subjected to a small flame*
- [3] ISO 5725:1986, *Precision of test methods — Determination of repeatability and reproducibility for a standard test method by inter-laboratory tests* (now withdrawn)

British Standards Institution (BSI)

BSI is the national body responsible for preparing British Standards and other standards-related publications, information and services.

BSI is incorporated by Royal Charter. British Standards and other standardization products are published by BSI Standards Limited.

About us

We bring together business, industry, government, consumers, innovators and others to shape their combined experience and expertise into standards-based solutions.

The knowledge embodied in our standards has been carefully assembled in a dependable format and refined through our open consultation process. Organizations of all sizes and across all sectors choose standards to help them achieve their goals.

Information on standards

We can provide you with the knowledge that your organization needs to succeed. Find out more about British Standards by visiting our website at bsigroup.com/standards or contacting our Customer Services team or Knowledge Centre.

Buying standards

You can buy and download PDF versions of BSI publications, including British and adopted European and international standards, through our website at bsigroup.com/shop, where hard copies can also be purchased.

If you need international and foreign standards from other Standards Development Organizations, hard copies can be ordered from our Customer Services team.

Subscriptions

Our range of subscription services are designed to make using standards easier for you. For further information on our subscription products go to bsigroup.com/subscriptions.

With **British Standards Online (BSOL)** you'll have instant access to over 55,000 British and adopted European and international standards from your desktop. It's available 24/7 and is refreshed daily so you'll always be up to date.

You can keep in touch with standards developments and receive substantial discounts on the purchase price of standards, both in single copy and subscription format, by becoming a **BSI Subscribing Member**.

PLUS is an updating service exclusive to BSI Subscribing Members. You will automatically receive the latest hard copy of your standards when they're revised or replaced.

To find out more about becoming a BSI Subscribing Member and the benefits of membership, please visit bsigroup.com/shop.

With a **Multi-User Network Licence (MUNL)** you are able to host standards publications on your intranet. Licences can cover as few or as many users as you wish. With updates supplied as soon as they're available, you can be sure your documentation is current. For further information, email bsmusales@bsigroup.com.

BSI Group Headquarters

389 Chiswick High Road London W4 4AL UK

Revisions

Our British Standards and other publications are updated by amendment or revision.

We continually improve the quality of our products and services to benefit your business. If you find an inaccuracy or ambiguity within a British Standard or other BSI publication please inform the Knowledge Centre.

Copyright

All the data, software and documentation set out in all British Standards and other BSI publications are the property of and copyrighted by BSI, or some person or entity that owns copyright in the information used (such as the international standardization bodies) and has formally licensed such information to BSI for commercial publication and use. Except as permitted under the Copyright, Designs and Patents Act 1988 no extract may be reproduced, stored in a retrieval system or transmitted in any form or by any means – electronic, photocopying, recording or otherwise – without prior written permission from BSI. Details and advice can be obtained from the Copyright & Licensing Department.

Useful Contacts:

Customer Services

Tel: +44 845 086 9001

Email (orders): orders@bsigroup.com

Email (enquiries): cservices@bsigroup.com

Subscriptions

Tel: +44 845 086 9001

Email: subscriptions@bsigroup.com

Knowledge Centre

Tel: +44 20 8996 7004

Email: knowledgecentre@bsigroup.com

Copyright & Licensing

Tel: +44 20 8996 7070

Email: copyright@bsigroup.com



...making excellence a habit.™