



## BSI Standards Publication

**Aerospace — Nuts, hexagonal, slotted (castellated), reduced height, normal across flats, with MJ threads, classifications: 450 MPa (at ambient temperature)/120 °C, 450 MPa (at ambient temperature)/235 °C, 600 MPa (at ambient temperature)/425 °C, 900 MPa (at ambient temperature)/235 °C, 900 MPa (at ambient temperature)/315 °C, 900 MPa (at ambient temperature)/650 °C, 1 100 MPa (at ambient temperature)/235 °C, 1 100 MPa (at ambient temperature)/730 °C and 1 250 MPa (at ambient temperature)/600 °C —**

**National foreword**

This British Standard is the UK implementation of ISO 9618:2016. It supersedes BS A 315:1997 which is withdrawn.

The UK participation in its preparation was entrusted to Technical Committee ACE/12, Aerospace fasteners and fastening systems.

A list of organizations represented on this committee can be obtained on request to its secretary.

This publication does not purport to include all the necessary provisions of a contract. Users are responsible for its correct application.

© The British Standards Institution 2016.

Published by BSI Standards Limited 2016

ISBN 978 0 580 86450 6

ICS 49.030.30

**Compliance with a British Standard cannot confer immunity from legal obligations.**

This British Standard was published under the authority of the Standards Policy and Strategy Committee on 31 March 2016.

**Amendments/corrigenda issued since publication**

Date	Text affected
------	---------------

---

---

---

**Aerospace — Nuts, hexagonal, slotted (castellated), reduced height, normal across flats, with MJ threads, classifications: 450 MPa (at ambient temperature)/120 °C, 450 MPa (at ambient temperature)/235 °C, 600 MPa (at ambient temperature)/425 °C, 900 MPa (at ambient temperature)/235 °C, 900 MPa (at ambient temperature)/315 °C, 900 MPa (at ambient temperature)/650 °C, 1 100 MPa (at ambient temperature)/235 °C, 1 100 MPa (at ambient temperature)/730 °C and 1 250 MPa (at ambient temperature)/600 °C — Dimensions**

*Aéronautique et espace — Écrous hexagonaux à créneaux, hauteur réduite, surplats normaux, à filetage MJ, classifications: 450 MPa (à température ambiante)/120 °C, 450 MPa (à température ambiante)/235 °C, 600 MPa (à température ambiante)/425 °C, 900 MPa (à température ambiante)/235 °C, 900 MPa (à température ambiante)/315 °C, 900 MPa (à température ambiante)/650 °C, 1 100 MPa (à température ambiante)/235 °C, 1 100 MPa (à température ambiante)/730 °C et 1 250 MPa (à température ambiante)/600 °C — Dimensions*



## **COPYRIGHT PROTECTED DOCUMENT**

© ISO 2016, Published in Switzerland

All rights reserved. Unless otherwise specified, no part of this publication may be reproduced or utilized otherwise in any form or by any means, electronic or mechanical, including photocopying, or posting on the internet or an intranet, without prior written permission. Permission can be requested from either ISO at the address below or ISO's member body in the country of the requester.

ISO copyright office  
Ch. de Blandonnet 8 • CP 401  
CH-1214 Vernier, Geneva, Switzerland  
Tel. +41 22 749 01 11  
Fax +41 22 749 09 47  
copyright@iso.org  
www.iso.org

# Contents

Page

<b>Foreword</b> .....	<b>iv</b>
<b>Introduction</b> .....	<b>v</b>
<b>1 Scope</b> .....	<b>1</b>
<b>2 Normative references</b> .....	<b>1</b>
<b>3 Configuration and dimensions</b> .....	<b>1</b>

## Foreword

ISO (the International Organization for Standardization) is a worldwide federation of national standards bodies (ISO member bodies). The work of preparing International Standards is normally carried out through ISO technical committees. Each member body interested in a subject for which a technical committee has been established has the right to be represented on that committee. International organizations, governmental and non-governmental, in liaison with ISO, also take part in the work. ISO collaborates closely with the International Electrotechnical Commission (IEC) on all matters of electrotechnical standardization.

The procedures used to develop this document and those intended for its further maintenance are described in the ISO/IEC Directives, Part 1. In particular the different approval criteria needed for the different types of ISO documents should be noted. This document was drafted in accordance with the editorial rules of the ISO/IEC Directives, Part 2 (see [www.iso.org/directives](http://www.iso.org/directives)).

Attention is drawn to the possibility that some of the elements of this document may be the subject of patent rights. ISO shall not be held responsible for identifying any or all such patent rights. Details of any patent rights identified during the development of the document will be in the Introduction and/or on the ISO list of patent declarations received (see [www.iso.org/patents](http://www.iso.org/patents)).

Any trade name used in this document is information given for the convenience of users and does not constitute an endorsement.

For an explanation on the meaning of ISO specific terms and expressions related to conformity assessment, as well as information about ISO's adherence to the WTO principles in the Technical Barriers to Trade (TBT) see the following URL: [Foreword - Supplementary information](#).

The committee responsible for this document is ISO/TC 20, *Aircraft and space vehicles*, Subcommittee SC 4, *Aerospace fastener systems*.

This second edition cancels and replaces the first edition (ISO 9618:1996), of which it constitutes a minor revision.

## Introduction

The dimensions specified in this International Standard have been determined to satisfy the requirements of the procurement specification which will be the subject of a future International Standard.





# **Aerospace — Nuts, hexagonal, slotted (castellated), reduced height, normal across flats, with MJ threads, classifications: 450 MPa (at ambient temperature)/120 °C, 450 MPa (at ambient temperature)/235 °C, 600 MPa (at ambient temperature)/425 °C, 900 MPa (at ambient temperature)/235 °C, 900 MPa (at ambient temperature)/315 °C, 900 MPa (at ambient temperature)/650 °C, 1 100 MPa (at ambient temperature)/235 °C, 1 100 MPa (at ambient temperature)/730 °C and 1 250 MPa (at ambient temperature)/600 °C — Dimensions**

## **1 Scope**

This International Standard specifies the dimensions of hexagon slotted (castellated) nuts, reduced height, normal across flats, with MJ threads, of classifications: 450 MPa/120 °C, 450 MPa/235 °C, 600 MPa/425 °C, 900 MPa/235 °C, 900 MPa/315 °C, 900 MPa/650 °C, 1 100 MPa/235 °C, 1 100 MPa/730 °C, and 1 250 MPa/600 °C.

NOTE 1 450 MPa, 600 MPa, 900 MPa, 1 100 MPa and 1 250 MPa corresponds to the minimum tensile stress which the nut is able to withstand at ambient temperature without breaking or cracking when tested with a bolt of a higher strength class.

NOTE 2 120 °C, 235 °C, 425 °C, 315 °C, 650 °C, 730 °C and 600 °C corresponds to the maximum temperature that the nut is able to withstand without permanent alteration to its original characteristics, after ambient temperature has been restored. The maximum temperature is conditioned by the surface treatment.

These nuts are intended to be used with split pins in conformity with ISO 1234.

This International Standard is applicable for the compilation of aerospace product standards.

## **2 Normative references**

The following documents, in whole or in part, are normatively referenced in this document and are indispensable for its application. For dated references, only the edition cited applies. For undated references, the latest edition of the referenced document (including any amendments) applies.

ISO 1234, *Split pins*

ISO 5855-2, *Aerospace — MJ threads — Part 2: Limit dimensions for bolts and nuts*

ISO 8788, *Aerospace — Nuts, metric — Tolerances of form and position*

## **3 Configuration and dimensions**

See [Figure 1](#) and [Table 1](#). Dimensions and tolerances are expressed in millimetres. They apply after any surface coating(s) but before the application of any lubricant.

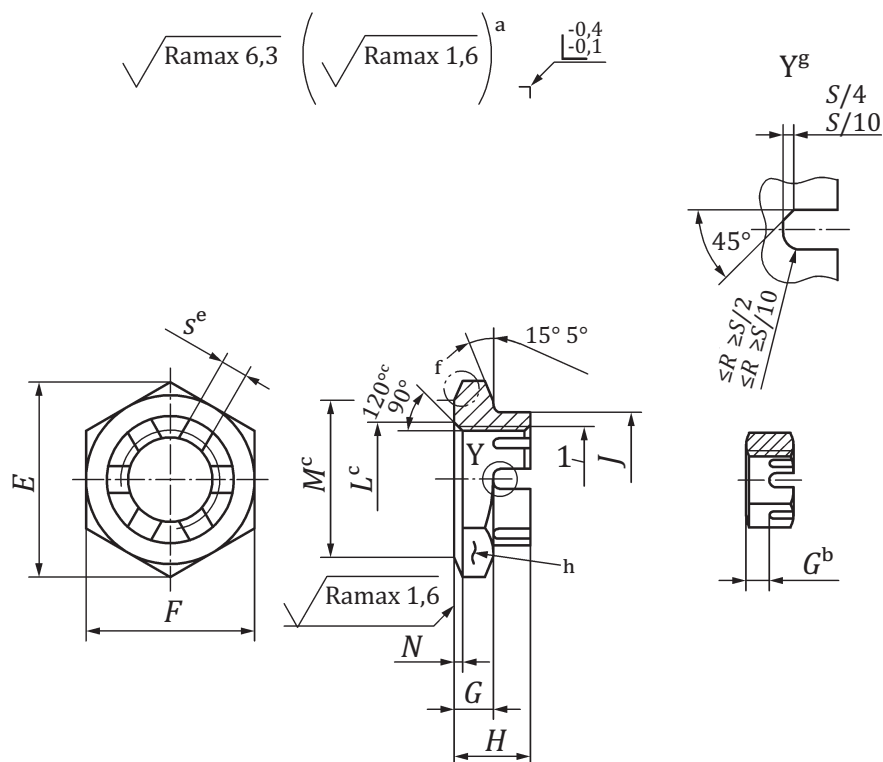

**Key**

- a These values, in micrometres, apply before any surface coating(s) is/are applied. The values do not apply to threads the surface texture of which will be as achieved by the usual manufacturing methods
- b Applies to height below slots and height of flats (diameter codes 060 to 240).
- c This dimension also applies to the upper chamfer. All forms of entry (chamfer or radius) permissible within these limiting dimensions.
- d Diameter  $M$  may be tangential to, but shall not intrude on the flats.
- e 6 slots.
- f Form of contour within limiting dimensions at manufacturer's option
- g (4:1) Form (radius or chamfer) at bottom of slot at manufacturer's option.

NOTE Tolerances of form and position shall conform to those specified in ISO 8788. Details of form not stated are at the manufacturer's discretion.

**Figure 1 — Configurations and dimensions**

**Table 1 — Dimensions**

Dimensions in millimetres

Diameter code	Thread <sup>a</sup>	E	F	G	H	J	L	M	N	S	Maximum split pin diameter <sup>b</sup>
040	MJ4 × 0,7 – 4H6H	7,6	h12	2,1	4,1	—	4,2	6,4	0 −0,3	H14	1,0
050	MJ5 × 0,8 – 4H6H	8,7		8	2,4	4,8	—	5,2			
060	MJ6 × 1 – 4H5H	10,9	h13	3,0	5,4	9	6,3	9,3	0,5	1,7	1,4
070	MJ7 × 1 – 4H5H	12,0			11	5,8	10	7,3			
080	MJ8 × 1 – 4H5H	14,3	13	3,2	6,0	11	8,3	12,2	2,1	1,8	
100	MJ10 × 1,25 – 4H5H	18,9	17	4,0	7,6	13	10,3	16,0			
120	MJ12 × 1,25 – 4H5H	21,1	19	4,8	8,4	16	12,3	18,0	2,6	2,3	
140	MJ14 × 1,5 – 4H5H	24,5	22	5,6	10,0	18	14,4	21,0			
160	MJ16 × 1,5 – 4H5H	26,8	24	6,4	10,8	22	16,4	23,0	0,6	3,2	2,9
180	MJ18 × 1,5 – 4H5H	30,2	27	7,2	12,4	25	18,4	26,0			
200	MJ20 × 1,5 – 4H5H	33,6	30	8,0	13,2	28	20,4	29,0	4,0	3,7	
220	MJ22 × 1,5 – 4H5H	35,8	32	8,8	14,0	30	22,4	30,9			
240	MJ24 × 2 – 4H5H	40,4	36	9,6	14,8	32	24,5	34,9			

<sup>a</sup> In accordance with ISO 5855-2.

<sup>b</sup> For information, in conformity with ISO 1234 for the split pin maximum diameter but not for the split pin maximum diameter/thread diameter combination.





# British Standards Institution (BSI)

BSI is the national body responsible for preparing British Standards and other standards-related publications, information and services.

BSI is incorporated by Royal Charter. British Standards and other standardization products are published by BSI Standards Limited.

## About us

We bring together business, industry, government, consumers, innovators and others to shape their combined experience and expertise into standards-based solutions.

The knowledge embodied in our standards has been carefully assembled in a dependable format and refined through our open consultation process. Organizations of all sizes and across all sectors choose standards to help them achieve their goals.

## Information on standards

We can provide you with the knowledge that your organization needs to succeed. Find out more about British Standards by visiting our website at [bsigroup.com/standards](http://bsigroup.com/standards) or contacting our Customer Services team or Knowledge Centre.

## Buying standards

You can buy and download PDF versions of BSI publications, including British and adopted European and international standards, through our website at [bsigroup.com/shop](http://bsigroup.com/shop), where hard copies can also be purchased.

If you need international and foreign standards from other Standards Development Organizations, hard copies can be ordered from our Customer Services team.

## Subscriptions

Our range of subscription services are designed to make using standards easier for you. For further information on our subscription products go to [bsigroup.com/subscriptions](http://bsigroup.com/subscriptions).

With **British Standards Online (BSOL)** you'll have instant access to over 55,000 British and adopted European and international standards from your desktop. It's available 24/7 and is refreshed daily so you'll always be up to date.

You can keep in touch with standards developments and receive substantial discounts on the purchase price of standards, both in single copy and subscription format, by becoming a **BSI Subscribing Member**.

**PLUS** is an updating service exclusive to BSI Subscribing Members. You will automatically receive the latest hard copy of your standards when they're revised or replaced.

To find out more about becoming a BSI Subscribing Member and the benefits of membership, please visit [bsigroup.com/shop](http://bsigroup.com/shop).

With a **Multi-User Network Licence (MUNL)** you are able to host standards publications on your intranet. Licences can cover as few or as many users as you wish. With updates supplied as soon as they're available, you can be sure your documentation is current. For further information, email [bsmusales@bsigroup.com](mailto:bsmusales@bsigroup.com).

## Revisions

Our British Standards and other publications are updated by amendment or revision.

We continually improve the quality of our products and services to benefit your business. If you find an inaccuracy or ambiguity within a British Standard or other BSI publication please inform the Knowledge Centre.

## Copyright

All the data, software and documentation set out in all British Standards and other BSI publications are the property of and copyrighted by BSI, or some person or entity that owns copyright in the information used (such as the international standardization bodies) and has formally licensed such information to BSI for commercial publication and use. Except as permitted under the Copyright, Designs and Patents Act 1988 no extract may be reproduced, stored in a retrieval system or transmitted in any form or by any means – electronic, photocopying, recording or otherwise – without prior written permission from BSI. Details and advice can be obtained from the Copyright & Licensing Department.

## Useful Contacts:

### Customer Services

**Tel:** +44 845 086 9001

**Email (orders):** [orders@bsigroup.com](mailto:orders@bsigroup.com)

**Email (enquiries):** [cservices@bsigroup.com](mailto:cservices@bsigroup.com)

### Subscriptions

**Tel:** +44 845 086 9001

**Email:** [subscriptions@bsigroup.com](mailto:subscriptions@bsigroup.com)

### Knowledge Centre

**Tel:** +44 20 8996 7004

**Email:** [knowledgecentre@bsigroup.com](mailto:knowledgecentre@bsigroup.com)

### Copyright & Licensing

**Tel:** +44 20 8996 7070

**Email:** [copyright@bsigroup.com](mailto:copyright@bsigroup.com)

## BSI Group Headquarters

389 Chiswick High Road London W4 4AL UK

