

BS ISO 9599:2015



BSI Standards Publication

**Copper, lead, zinc and nickel  
sulfide concentrates —  
Determination of hygroscopic  
moisture content of the  
analysis sample — Gravimetric  
method**

**bsi.**

...making excellence a habit.™

**National foreword**

This British Standard is the UK implementation of ISO 9599:2015.

The UK participation in its preparation was entrusted to Technical Committee NFE/36, Copper lead and zinc ores and concentrates.

A list of organizations represented on this committee can be obtained on request to its secretary.

This publication does not purport to include all the necessary provisions of a contract. Users are responsible for its correct application.

© The British Standards Institution 2015.  
Published by BSI Standards Limited 2015

ISBN 978 0 580 87931 9

ICS 73.060.99

**Compliance with a British Standard cannot confer immunity from legal obligations.**

This British Standard was published under the authority of the Standards Policy and Strategy Committee on 31 October 2015.

**Amendments issued since publication**

Date	Text affected
------	---------------

---

---

---

**Copper, lead, zinc and nickel sulfide  
concentrates — Determination of  
hygroscopic moisture content of the  
analysis sample — Gravimetric method**

*Éléments concentrés sulfurés de cuivre, de plomb et de zinc —  
Détermination de l'humidité hygroscopique dans l'échantillon pour  
analyse — Méthode gravimétrique*





**COPYRIGHT PROTECTED DOCUMENT**

© ISO 2015, Published in Switzerland

All rights reserved. Unless otherwise specified, no part of this publication may be reproduced or utilized otherwise in any form or by any means, electronic or mechanical, including photocopying, or posting on the internet or an intranet, without prior written permission. Permission can be requested from either ISO at the address below or ISO's member body in the country of the requester.

ISO copyright office  
Ch. de Blandonnet 8 • CP 401  
CH-1214 Vernier, Geneva, Switzerland  
Tel. +41 22 749 01 11  
Fax +41 22 749 09 47  
copyright@iso.org  
www.iso.org

# Contents

Page

<b>Foreword</b> .....	<b>iv</b>
<b>1 Scope</b> .....	<b>1</b>
<b>2 Normative references</b> .....	<b>1</b>
<b>3 Principle</b> .....	<b>1</b>
<b>4 Reagents</b> .....	<b>1</b>
<b>5 Apparatus</b> .....	<b>1</b>
<b>6 Sampling and samples</b> .....	<b>2</b>
6.1 General.....	2
6.2 Laboratory sample.....	2
6.3 Preparation of the test sample.....	2
<b>7 Procedure</b> .....	<b>2</b>
7.1 Preparation of the weighing vessel.....	2
7.2 Test portion.....	2
7.3 Determination.....	2
<b>8 Expression of results</b> .....	<b>3</b>
<b>9 Test report (for internal laboratory use only)</b> .....	<b>3</b>
<b>Annex A (normative) Method for samples susceptible to oxidation — Drying in nitrogen</b> .....	<b>4</b>

## Foreword

ISO (the International Organization for Standardization) is a worldwide federation of national standards bodies (ISO member bodies). The work of preparing International Standards is normally carried out through ISO technical committees. Each member body interested in a subject for which a technical committee has been established has the right to be represented on that committee. International organizations, governmental and non-governmental, in liaison with ISO, also take part in the work. ISO collaborates closely with the International Electrotechnical Commission (IEC) on all matters of electrotechnical standardization.

The procedures used to develop this document and those intended for its further maintenance are described in the ISO/IEC Directives, Part 1. In particular the different approval criteria needed for the different types of ISO documents should be noted. This document was drafted in accordance with the editorial rules of the ISO/IEC Directives, Part 2 (see [www.iso.org/directives](http://www.iso.org/directives)).

Attention is drawn to the possibility that some of the elements of this document may be the subject of patent rights. ISO shall not be held responsible for identifying any or all such patent rights. Details of any patent rights identified during the development of the document will be in the Introduction and/or on the ISO list of patent declarations received (see [www.iso.org/patents](http://www.iso.org/patents)).

Any trade name used in this document is information given for the convenience of users and does not constitute an endorsement.

For an explanation on the meaning of ISO specific terms and expressions related to conformity assessment, as well as information about ISO's adherence to the WTO principles in the Technical Barriers to Trade (TBT) see the following URL: [Foreword - Supplementary information](#)

ISO 9599 was prepared by Technical Committee ISO/TC 183, *Copper, lead, zinc and nickel ores and concentrates*.

This second edition cancels and replaces the first edition (ISO 9599:1991), which has been technically revised.

# Copper, lead, zinc and nickel sulfide concentrates — Determination of hygroscopic moisture content of the analysis sample — Gravimetric method

**WARNING** — Any chemical-reagent waste must be disposed of in an environmentally sound manner that does not injure the health or welfare of the environment, people, animals, vegetation, etc.

## 1 Scope

This International Standard specifies a gravimetric loss-in-mass method for the determination of the hygroscopic moisture content in analysis samples of copper, lead, zinc, and nickel sulfide concentrates.

The method is applicable to copper, lead, zinc, and nickel sulfide concentrates free from volatile organic flotation reagents, for example kerosene, and with hygroscopic moisture contents between 0,05 % (m/m) and 2 % (m/m). The hygroscopic moisture content is used to correct the analysis results from the equilibrated moisture level to the dry basis.

**NOTE** The result of the determination of hygroscopic moisture content using this International Standard should not be reported as part of the analysis of a concentrate sample. Whenever the bulk moisture content of a commercial shipment of concentrate is required, ISO 10251 should be used. The determination of hygroscopic moisture content and the determination of bulk moisture content are connected with each other. In both determinations, the same state of dryness has to be achieved, in order to ascertain the correct metal content of a lot.

This method is not applicable to sulfide concentrates that are susceptible to oxidation (see 6.3, note 2). [Annex A](#) sets out a modified procedure, which can be used for sulfide concentrates that are susceptible to oxidation.

## 2 Normative references

The following referenced documents are indispensable for the application of this document. For dated references, only the edition cited applies. For undated references, the latest edition of the referenced document (including any amendments) applies.

ISO 10251, *Copper, lead, zinc and nickel concentrates — Determination of mass loss of bulk material on drying*

ISO 12743, *Copper, lead, zinc and nickel concentrates — Sampling procedures for determination of metal and moisture content*

## 3 Principle

Drying of a weighed test portion in air in an oven maintained at  $105\text{ °C} \pm 5\text{ °C}$  and calculation of the percentage moisture content from the loss in mass.

## 4 Reagents

**4.1 Desiccant**, such as self-indicating silica gel or anhydrous magnesium perchlorate.

## 5 Apparatus

Ordinary laboratory equipment, and the following.

**5.1 Analytical balance**, sensitive to 0,1 mg.

**5.2 Laboratory oven**, capable of maintaining a temperature of  $105\text{ °C} \pm 5\text{ °C}$ .

**5.3 Weighing vessel**, shallow, of glass or silica or corrosion-resistant metal, with an externally fitting air-tight cover of approximately 50 mm diameter.

**5.4 Flat dish, or tray**.

## 6 Sampling and samples

### 6.1 General

Sampling and sample preparation shall be according to ISO 12743.

### 6.2 Laboratory sample

Use a sample of minus 150  $\mu\text{m}$  particle size.

### 6.3 Preparation of the test sample

Take a sufficient mass of the laboratory sample for the required chemical analysis and moisture determination and transfer to a flat dish or tray (5.4). Spread the sample evenly into a thin layer about 3 mm to 5 mm thick. Cover the dish to protect the sample from dust, but allowing a free flow of air across the top of the sample. Allow the test sample to equilibrate with the laboratory atmosphere for 2 h or for long enough to achieve equilibration.

Equilibration is achieved whenever the change in mass of the test sample over a 2 h period of exposure is less than 0,1 %.

## 7 Procedure

### 7.1 Preparation of the weighing vessel

Dry a weighing vessel and cover (5.3) by heating in the laboratory oven (5.2) at  $105\text{ °C} \pm 5\text{ °C}$  for 1 h. Transfer the weighing vessel and cover to a desiccator containing a suitable fresh desiccant (4.1), and allow to cool to ambient temperature. Remove the weighing vessel and cover from the desiccator and weigh to the nearest 0,1 mg (mass  $m_1$ ), after slightly lifting the weighing vessel cover and quickly replacing it.

### 7.2 Test portion

Transfer approximately 10 g of the equilibrated test sample (6.2) directly to the dried and tared weighing vessel (7.1), spreading in an even layer about 3 mm to 5 mm thick. Record the mass of the weighing vessel and cover plus test portion to the nearest 0,1 mg (mass  $m_2$ ). Within the following 5 min, also weigh the test portions required for the determination of constituents for which correction of the analytical values to a dry basis is required and transfer such test portions to the appropriate receptacles required for subsequent testing.

### 7.3 Determination

Transfer the uncovered weighing vessel containing the test portion and the vessel cover to the laboratory oven (5.2) and dry at  $105\text{ °C} \pm 5\text{ °C}$  for 2 h. After the 2 h period, remove the weighing vessel containing the dry test portion from the oven, replace the cover and allow cooling to ambient temperature in the desiccator. Whenever cool, remove the weighing vessel containing the dry test portion and the vessel



cover from the desiccator and reweigh to the nearest 0,1 mg, after slightly lifting the weighing vessel cover and quickly replacing it.

Repeat the drying at  $105\text{ °C} \pm 5\text{ °C}$  for another 2 h, cool to ambient temperature in the desiccator and weigh to determine if constant mass ( $\pm 1\text{ mg}$ ) has been achieved. If constant mass has not been achieved, repeat the drying and weighing steps described above. Record the constant mass ( $m_3$ ).

NOTE If constant mass ( $\pm 1\text{ mg}$ ) is not achieved after three drying periods of 2 h, then the method specified in [Annex A](#) should be used.

## 8 Expression of results

The hygroscopic moisture content,  $H$ , expressed as a percentage by mass, is calculated from the formula

$$H = \frac{m_2 - m_3}{m_2 - m_1} \times 100$$

where

$m_1$  is the mass, in grams, of the dried weighing vessel plus cover;

$m_2$  is the mass, in grams, of the weighing vessel plus cover plus test portion before drying;

$m_3$  is the mass, in grams, of the weighing vessel plus cover plus test portion after drying.

Calculate the hygroscopic moisture content of the sample to the second decimal place.

## 9 Test report (for internal laboratory use only)

The test report shall contain the following information:

- a) identification of the sample;
- b) reference to this International Standard;
- c) hygroscopic moisture content of the sample;
- d) date on which the test was carried out.

## Annex A (normative)

### Method for samples susceptible to oxidation — Drying in nitrogen

#### A.1 Principle

Drying of a weighed test portion in oxygen-free, dry nitrogen in an oven maintained at  $105\text{ °C} \pm 5\text{ °C}$  and calculation of the percentage moisture content from the loss in mass.

#### A.2 Reagents

**A.2.1 Nitrogen**, dry gas containing less than 30  $\mu\text{l}$  of oxygen per litre.

**A.2.2 Desiccant**, such as self-indicating silica gel or anhydrous magnesium perchlorate.

#### A.3 Apparatus

Ordinary laboratory equipment, and the following.

**A.3.1 Analytical balance**, sensitive to 0,1 mg.

**A.3.2 Minimum-free-space oven**, capable of maintaining a temperature of  $105\text{ °C} \pm 5\text{ °C}$ , with provision for pre-heated nitrogen ([A.2.1](#)) to pass through the oven at 15 to 20 oven-volumes per hour. A suitable oven is shown in [Figure A.1](#).

**A.3.3 Weighing vessel**, shallow, of glass or silica or corrosion-resistant metal, with an externally fitting air-tight cover of approximately 50 mm diameter.

**A.3.4 Flowmeter**, capable of measuring the rate of flow of nitrogen ([A.2.1](#)) through the oven ([A.3.2](#)).

**A.3.5 Drying tower**, of approximately 250 ml capacity, packed with anhydrous magnesium perchlorate ([A.2.2](#)) for drying the nitrogen ([A.2.1](#)).

#### A.4 Procedure

##### A.4.1 Preparation of the weighing vessel

Raise the temperature of the oven ([A.3.2](#)) to  $105\text{ °C} \pm 5\text{ °C}$  while passing nitrogen ([A.2.1](#)) through the oven at the rate of 15 to 20 oven-volumes per hour.

Dry a weighing vessel and cover ([A.3.3](#)) by heating in the oven at  $105\text{ °C} \pm 5\text{ °C}$  for 1 h. Transfer the weighing vessel and cover to a desiccator containing a suitable fresh desiccant ([A.2.2](#)), and allow to cool to ambient temperature. Remove the weighing vessel and cover from the desiccator and weigh to the nearest 0,1 mg (mass  $m_1$ ), after slightly lifting the weighing vessel cover and quickly replacing it.

Dimensions in millimetres

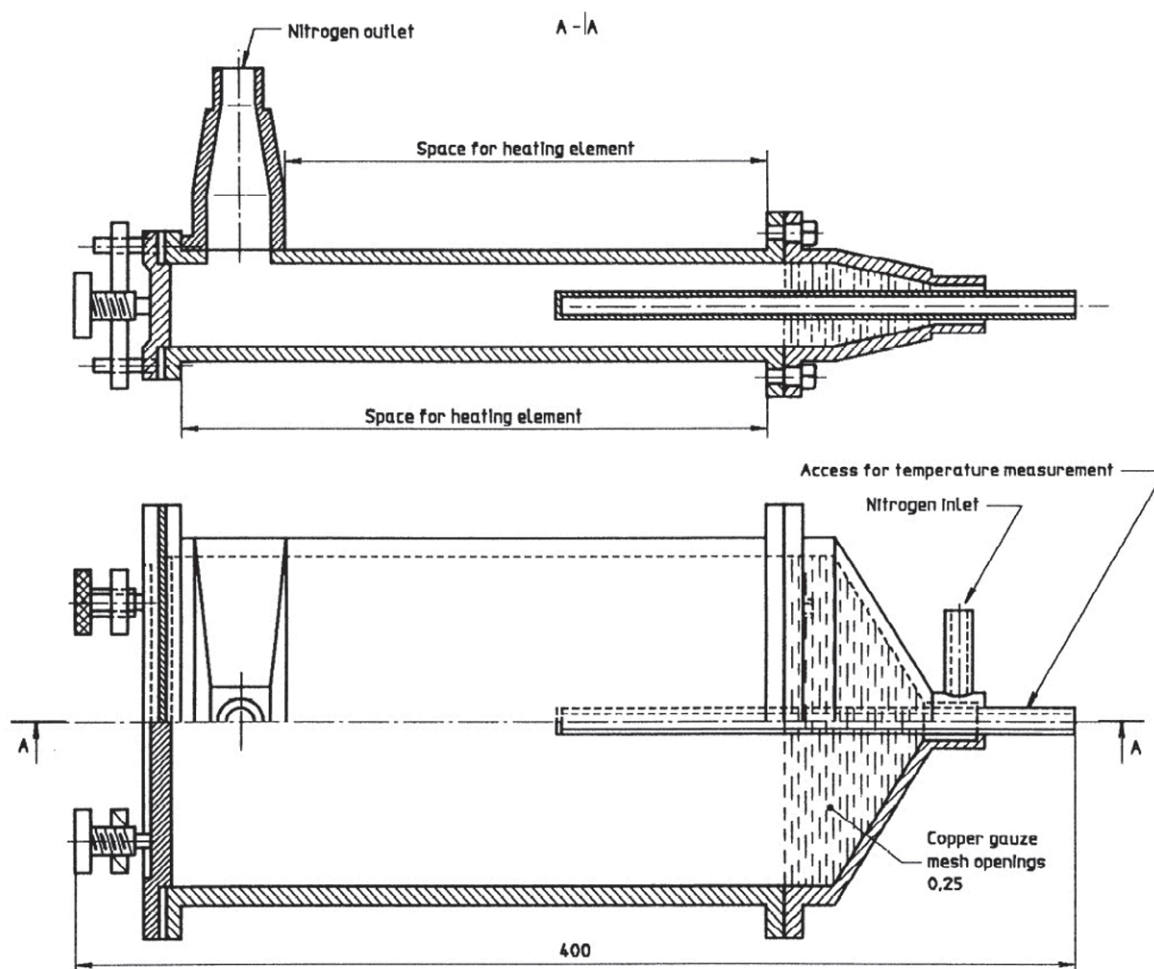

Figure A.1 — Suitable nitrogen oven

#### A.4.2 Test portion

Transfer approximately 10 g of the equilibrated test sample (5.2) directly into the dried and tared weighing vessel (A.4.1), spreading the sample in an even layer about 3 mm to 5 mm thick. Record the mass of the weighing vessel and cover plus test portion to the nearest 0,1 mg (mass  $m_2$ ).

#### A.4.3 Determination

Transfer the uncovered weighing vessel containing the test portion and the vessel cover to the oven (A.3.2) and dry at  $105\text{ °C} \pm 5\text{ °C}$  until constant mass ( $\pm 1\text{ mg}$ ) is achieved (see Note).

NOTE Under the conditions described above, drying should be complete in between 1,5 h and 3 h. Constancy in mass ( $\pm 1\text{ mg}$ ) should be established by reheating at  $105\text{ °C} \pm 5\text{ °C}$  for a further period of 30 min, followed by cooling and weighing as described.

Remove the weighing vessel containing the dry test portion from the oven, replace the cover and allow cooling to ambient temperature in the desiccator. Whenever cool, remove the weighing vessel containing the test portion and the vessel cover from the desiccator and reweigh to the nearest 0,1 mg (mass  $m_3$ ), after slightly lifting the weighing vessel cover and quickly replacing it.

## A.5 Expression of results

The hygroscopic moisture content,  $H$ , expressed as a percentage by mass, is calculated from the formula

$$H = \frac{m_2 - m_3}{m_2 - m_1} \times 100$$

where

$m_1$  is the mass, in grams, of the dried weighing vessel plus cover;

$m_2$  is the mass, in grams, of the weighing vessel plus cover plus test portion before drying;

$m_3$  is the mass, in grams, of the weighing vessel plus cover plus test portion after drying.

Calculate the hygroscopic moisture content of the sample to the second decimal place.

## A.6 Test report (for internal laboratory use only)

The test report shall contain the following information:

- a) identification of the sample;
- b) reference to this International Standard;
- c) hygroscopic moisture content of the sample;
- d) date on which the test was carried out.







# British Standards Institution (BSI)

BSI is the national body responsible for preparing British Standards and other standards-related publications, information and services.

BSI is incorporated by Royal Charter. British Standards and other standardization products are published by BSI Standards Limited.

## About us

We bring together business, industry, government, consumers, innovators and others to shape their combined experience and expertise into standards-based solutions.

The knowledge embodied in our standards has been carefully assembled in a dependable format and refined through our open consultation process. Organizations of all sizes and across all sectors choose standards to help them achieve their goals.

## Information on standards

We can provide you with the knowledge that your organization needs to succeed. Find out more about British Standards by visiting our website at [bsigroup.com/standards](http://bsigroup.com/standards) or contacting our Customer Services team or Knowledge Centre.

## Buying standards

You can buy and download PDF versions of BSI publications, including British and adopted European and international standards, through our website at [bsigroup.com/shop](http://bsigroup.com/shop), where hard copies can also be purchased.

If you need international and foreign standards from other Standards Development Organizations, hard copies can be ordered from our Customer Services team.

## Subscriptions

Our range of subscription services are designed to make using standards easier for you. For further information on our subscription products go to [bsigroup.com/subscriptions](http://bsigroup.com/subscriptions).

With **British Standards Online (BSOL)** you'll have instant access to over 55,000 British and adopted European and international standards from your desktop. It's available 24/7 and is refreshed daily so you'll always be up to date.

You can keep in touch with standards developments and receive substantial discounts on the purchase price of standards, both in single copy and subscription format, by becoming a **BSI Subscribing Member**.

**PLUS** is an updating service exclusive to BSI Subscribing Members. You will automatically receive the latest hard copy of your standards when they're revised or replaced.

To find out more about becoming a BSI Subscribing Member and the benefits of membership, please visit [bsigroup.com/shop](http://bsigroup.com/shop).

With a **Multi-User Network Licence (MUNL)** you are able to host standards publications on your intranet. Licences can cover as few or as many users as you wish. With updates supplied as soon as they're available, you can be sure your documentation is current. For further information, email [bsmusales@bsigroup.com](mailto:bsmusales@bsigroup.com).

## BSI Group Headquarters

389 Chiswick High Road London W4 4AL UK

## Revisions

Our British Standards and other publications are updated by amendment or revision.

We continually improve the quality of our products and services to benefit your business. If you find an inaccuracy or ambiguity within a British Standard or other BSI publication please inform the Knowledge Centre.

## Copyright

All the data, software and documentation set out in all British Standards and other BSI publications are the property of and copyrighted by BSI, or some person or entity that owns copyright in the information used (such as the international standardization bodies) and has formally licensed such information to BSI for commercial publication and use. Except as permitted under the Copyright, Designs and Patents Act 1988 no extract may be reproduced, stored in a retrieval system or transmitted in any form or by any means – electronic, photocopying, recording or otherwise – without prior written permission from BSI. Details and advice can be obtained from the Copyright & Licensing Department.

## Useful Contacts:

### Customer Services

**Tel:** +44 845 086 9001

**Email (orders):** [orders@bsigroup.com](mailto:orders@bsigroup.com)

**Email (enquiries):** [cservices@bsigroup.com](mailto:cservices@bsigroup.com)

### Subscriptions

**Tel:** +44 845 086 9001

**Email:** [subscriptions@bsigroup.com](mailto:subscriptions@bsigroup.com)

### Knowledge Centre

**Tel:** +44 20 8996 7004

**Email:** [knowledgecentre@bsigroup.com](mailto:knowledgecentre@bsigroup.com)

### Copyright & Licensing

**Tel:** +44 20 8996 7070

**Email:** [copyright@bsigroup.com](mailto:copyright@bsigroup.com)



...making excellence a habit.™