

Version correct as of 03/01/2015. (c) The British Standards Institution 2013 Licensed copy: Lee Shau Kee Library, HKUST. Version correct as of 03/01/2015. (c) The British Standards Institution 2013 Licensed copy: Lee Shau Kee Library, HKUST.

BS ISO 9533:2010



BSI Standards Publication

Earth-moving machinery — Machine-mounted audible travel alarms and forward horns — Test methods and performance criteria

bsi.

...making excellence a habit.™

National foreword

This British Standard is the UK implementation of ISO 9533:2010. It supersedes BS 6912-3:1990 which is withdrawn.

The UK participation in its preparation was entrusted to Technical Committee B/513/1, Earth moving machinery (International).

A list of organizations represented on this committee can be obtained on request to its secretary.

This publication does not purport to include all the necessary provisions of a contract. Users are responsible for its correct application.

© BSI 2010

ISBN 978 0 580 64586 0

ICS 53.100

Compliance with a British Standard cannot confer immunity from legal obligations.

This British Standard was published under the authority of the Standards Policy and Strategy Committee on 31 August 2010.

Amendments issued since publication

Date	Text affected
------	---------------

INTERNATIONAL STANDARD

BS ISO 9533:2010

ISO
9533

Second edition
2010-07-01

Earth-moving machinery — Machine-mounted audible travel alarms and forward horns — Test methods and performance criteria

Engins de terrassement — Avertisseurs sonores de déplacement et de recul montés sur engins — Méthodes d'essai et critères de performance



Reference number
ISO 9533:2010(E)

© ISO 2010

PDF disclaimer

This PDF file may contain embedded typefaces. In accordance with Adobe's licensing policy, this file may be printed or viewed but shall not be edited unless the typefaces which are embedded are licensed to and installed on the computer performing the editing. In downloading this file, parties accept therein the responsibility of not infringing Adobe's licensing policy. The ISO Central Secretariat accepts no liability in this area.

Adobe is a trademark of Adobe Systems Incorporated.

Details of the software products used to create this PDF file can be found in the General Info relative to the file; the PDF-creation parameters were optimized for printing. Every care has been taken to ensure that the file is suitable for use by ISO member bodies. In the unlikely event that a problem relating to it is found, please inform the Central Secretariat at the address given below.



COPYRIGHT PROTECTED DOCUMENT

© ISO 2010

All rights reserved. Unless otherwise specified, no part of this publication may be reproduced or utilized in any form or by any means, electronic or mechanical, including photocopying and microfilm, without permission in writing from either ISO at the address below or ISO's member body in the country of the requester.

ISO copyright office
Case postale 56 • CH-1211 Geneva 20
Tel. + 41 22 749 01 11
Fax + 41 22 749 09 47
E-mail copyright@iso.org
Web www.iso.org

Published in Switzerland

Contents

Page

Foreword	iv
1 Scope	1
2 Normative references	1
3 Terms and definitions	1
4 Apparatus	2
5 Test environment	3
5.1 Test area	3
5.2 Background noise	3
5.3 Climatic conditions	3
5.4 Wind	3
6 Machine preparation	3
6.1 Voltage	3
6.2 Engine and transmission	3
6.3 Equipment and attachments	4
6.4 Operator station	4
7 Test procedures	5
7.1 General	5
7.2 Setup for exterior alarm measurements	6
7.3 Audible travel alarm and forward horn measurement	6
7.4 Reverse and travel warning alarm measurement for operator location	8
7.5 Criteria	8
8 Alarm activation requirements	9
8.1 Reverse warning alarm	9
8.2 Forward horn	9
8.3 Travel warning alarm	10
9 Information to be reported	10
Annex A (informative) Example test worksheet	11
Annex B (informative) Apparatus for exterior alarm measurement	12
Annex C (informative) 1/3rd octave band test method for reverse and travel warning alarms	13
Bibliography	14

Foreword

ISO (the International Organization for Standardization) is a worldwide federation of national standards bodies (ISO member bodies). The work of preparing International Standards is normally carried out through ISO technical committees. Each member body interested in a subject for which a technical committee has been established has the right to be represented on that committee. International organizations, governmental and non-governmental, in liaison with ISO, also take part in the work. ISO collaborates closely with the International Electrotechnical Commission (IEC) on all matters of electrotechnical standardization.

International Standards are drafted in accordance with the rules given in the ISO/IEC Directives, Part 2.

The main task of technical committees is to prepare International Standards. Draft International Standards adopted by the technical committees are circulated to the member bodies for voting. Publication as an International Standard requires approval by at least 75 % of the member bodies casting a vote.

Attention is drawn to the possibility that some of the elements of this document may be the subject of patent rights. ISO shall not be held responsible for identifying any or all such patent rights.

ISO 9533 was prepared by Technical Committee ISO/TC 127, *Earth-moving machinery*, Subcommittee SC 2, *Safety, ergonomics and general requirements*.

This second edition cancels and replaces the first edition (ISO 9533:1989), which has been technically revised. Notably, test methods and criteria have been modified to include the evaluation of self-adjusting sound level alarms and travel warning alarms.

Earth-moving machinery — Machine-mounted audible travel alarms and forward horns — Test methods and performance criteria

1 Scope

This International Standard specifies a static method for determining the sound output performance and alarm activation requirements of audible travel alarms and forward horns mounted on earth-moving machinery, as defined in ISO 6165, for operation on work sites and travelling on public roads. It offers objective test methodologies and performance criteria.

It is applicable only to those alarms and horns that are installed on the earth-moving machinery. It does not specify the installation of one or more audible travel alarms or forward horns on particular machines. It addresses neither the laboratory testing of warning alarm functionality nor durability.

NOTE Earth-moving machine manufacturer's practices, worksite requirements and local, national or regional regulations could require the fitting of the alarms or horns specified in this International Standard.

2 Normative references

The following referenced documents are indispensable for the application of this document. For dated references, only the edition cited applies. For undated references, the latest edition of the referenced document (including any amendments) applies.

ISO 3411, *Earth-moving machinery — Physical dimensions of operators and minimum operator space envelope*

ISO 6165, *Earth-moving machinery — Basic types — Identification and terms and definitions*

ISO 6746-1, *Earth-moving machinery — Definitions of dimensions and codes — Part 1: Base machine*

IEC 61672-1, *Electroacoustics — Sound level meters — Part 1: Specifications*

3 Terms and definitions

For the purposes of this document, the following terms and definitions apply.

3.1

machine reference box

MRB

imaginary rectangular box that would just fit over the base machine according to ISO 6746-1, which excludes all equipment and attachment items such as buckets, dozers, backhoes, rippers and booms

3.2

audible travel alarm

machine-mounted audible alarm intended to warn or alert personnel of the potential hazard of the machine travelling under its own power

3.2.1
travel warning alarm

audible signal intended to warn or alert personnel, especially those near a machine, that the machine has been activated to travel under its own power

NOTE These alarms are normally associated with machines that have rotating upper structures.

3.2.2
reverse warning alarm

audible signal intended to warn personnel, especially those near the rear of a machine, that the machine has been activated to travel in a rearward direction under its own power

3.3
forward horn

audible signal activated by the operator of the machine intended to alert personnel near a machine, but especially near the front of the machine

NOTE A forward horn or horns can also be used as part of a theft or security alarm system for the machine.

3.4
fixed sound level alarm

audible travel alarm that produces a sound level independent of ambient sound levels

3.5
self-adjusting sound level alarm

audible travel alarm that automatically adjusts its sound level, throughout a defined range, in order to maintain a sound level differential between the output of the alarm and the ambient sound level measured by the alarm

3.6
ambient sound

all sounds in the test area not produced by the audible travel alarm(s)

3.7
free field

space with no reflecting surface within 30 m of the sound source or microphone in any direction except for the horizontal reflecting plane on which the test machine is located

4 Apparatus

4.1 Sound level meter with an extension cable or equivalent sound measurement system that meets the performance requirements of IEC 61672-1, Type 1.

It is recommended that for the purposes of this International Standard all sound pressure level measurements be rounded to the nearest whole number in decibels.

4.2 Acoustical calibrator, or equivalent measurement system, recommended to be used each day of measurement to calibrate the sound level meter prior to testing and for checking sensitivity drift after test completion. The effects of atmospheric pressure, temperature and use of a windscreen should be accounted for within the system calibration as recommended by the manufacturer of the instrumentation.

4.3 Microphone wind screen, designed for sound measurement and recommended by the manufacturer of the sound level meter or equivalent sound measuring system, which shall be used to maintain consistency from test to test and add protection to the microphone assembly.

4.4 Anemometer, or other device, for measuring ambient wind speed and direction, accurate to within $\pm 10\%$ at the highest recommended wind speed.

4.5 Engine rotational frequency indicator with an accuracy to within $\pm 2\%$ of the indicated engine rotational frequency.

4.6 Thermometer for measurement of ambient temperature accurate to within $\pm 2\text{ }^{\circ}\text{C}$.

NOTE Apparatus will also be needed for checking the test environment (see 5.1).

5 Test environment

5.1 Test area

The test area shall consist of a free field above a hard reflecting plane no rougher than non-porous asphalt. The test area bordered by the machine and the microphone shall also consist of a flat, horizontal surface or surface sloping downwards away from the centre of the test area. No reflective objects such as buildings should be within 30 m of the microphone or the machine being measured.

The test technician or test equipment shall be > 2 m from the sound-measuring microphone during exterior location measurements.

NOTE For further details giving the recommended test area configuration, see ISO 3744 and ISO 6393.

5.2 Background noise

The ambient A-weighted sound pressure level due to sources other than the earthmoving machinery under test, including wind effects, shall be at least 10 dB lower than the lowest measurement of interest.

5.3 Climatic conditions

Measurements shall not be carried out when precipitation, e.g. rain, snow or sleet, is falling or when the ground is snow-covered. The ambient temperature shall be within a temperature range -10°C to $+35^{\circ}\text{C}$.

NOTE For further details giving recommended climatic conditions, see ISO 6393.

5.4 Wind

The average wind speed at the test site shall be less than 8 m/s.

Wind speeds at each measurement location due to machine operation should also be below 8 m/s. For measurement locations where wind speeds are above this value, sound measuring equipment designed for high wind applications should be used.

6 Machine preparation

6.1 Voltage

Verify that the alarm activation voltage to the audible travel alarm(s) or forward horn is within the nominal operating voltage specified by the manufacturer of the travel warning alarm(s) or forward horn.

6.2 Engine and transmission

6.2.1 General

Under prevailing conditions, the machine shall be at a stabilized temperature for all its primary power systems at maximum governor engine speed (high idle).

6.2.2 Cooling system fan speed(s)

If the powertrain or hydraulic system or systems of the machine are fitted with an adjustable fan or fans, they shall operate during the test at maximum achievable fan speed at the engine speed as specified in Clause 7.

If equipped with an electric fan or fans, these shall be off when taking sound pressure measurements with the engine off.

6.3 Equipment and attachments

For testing, the equipment and attachment(s) for the most typical machine configuration as specified by the machine manufacturer shall be installed and in the carry position for travelling (see ISO 5006). The attachment position shall also be as specified by the manufacturer.

6.4 Operator station

6.4.1 Heating, ventilation and air-conditioning system

If the operator station is equipped with a heating, ventilation and air-conditioning (HVAC) system or systems, these shall be set to mid-setting during all tests, defined below. The ventilation ducts shall be open with the air flow directed out but away from the operator.

- For an Off/Low/High system, at mid-setting the HVAC fan setting(s) will be at “High”.
- For an Off/Position 1/Position 2/Position 3 system, the mid-setting will be Position 2.
- For a continuously variable system, the mid-setting is at or above 50 % of the maximum fan speed.

If the HVAC system consists of multiple systems, e.g. separate upper and lower controls, all systems shall be set to mid-setting.

NOTE For further details on fan speed and fan settings, see ISO 6393.

6.4.2 Operator size and location

For testing at the location of the operator, an operator should be selected whose physical dimensions are as close as possible to a medium operator, and within the limits for a small to a large operator, as defined in ISO 3411.

The seat shall be positioned in the mid-position for fore and aft and for vertical height, if adjustment is provided. The seat and head rest, if present, shall be adjusted to accommodate the operator and shall remain consistent during the test series.

6.4.3 Additional considerations

Other considerations for the operator station include eliminating non-typical machine noise such as radios and monitor alarms. For cab units, all windows and doors shall be closed. Cab interior materials and seals should be typical of the machine type and family.

7 Test procedures

7.1 General

Measurements shall be taken and recorded at the alarm and horn test measurement locations shown in Figure 1 and in accordance with Table 1.

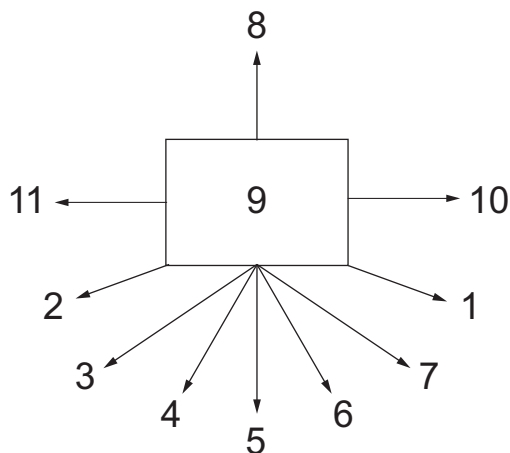

The rectangle represents the machine reference box (MRB) and the numbers indicate the test measurement locations. See Table 1.

NOTE Not drawn to scale.

Figure 1 — Test measurement locations in relation to MRB

Table 1 — Test measurement locations in relation to MRB

Location ^a	Coordinates: distance and direction m				As measured from
1	0,7	Right	0,7	Rear	Right rear corner
2	0,7	Left	0,7	Rear	Left rear corner
3	4,9	Left	4,9	Rear	Rear centre
4	2,7	Left	6,5	Rear	Rear centre
5	0,0	Centre	7,0	Rear	Rear centre
6	2,7	Right	6,5	Rear	Rear centre
7	4,9	Right	4,9	Rear	Rear centre
8	0,0	Centre	7,0	Front	Front centre
9	Location of operator				Ear height
10	0,0	Centre	7,0	Right	Right-side centre
11	0,0	Centre	7,0	Left	Left-side centre

NOTE Text in **bold italic** indicates travel warning alarm test points.

^a As per Figure 1.

An optional test method using 1/3rd octave bands to evaluate warning alarm performance is given in Annex C.

7.2 Setup for exterior alarm measurements

All sound measurements should be taken with the sound level meter set to “Fast response time weighting”, as defined in IEC 61672-1.

Sound measurements shall be taken for a minimum duration of 1 min at each test measurement location. When testing forward horns, such as electro-mechanical horns, sound measurements should not exceed a 1 min activation time without a pause between activations. The length of this pause should be specified by the horn manufacturer. Sound measurements performed on forward horns can be taken in minimum increments of 30 s.

The centre point of the measurement location should be $1,2\text{ m} \pm 0,05\text{ m}$ from the ground with the normal to the rotational plane at 0° to 45° up from horizontal and facing the centre line of the MRB. The microphone should be held perpendicular to this plane and a minimum distance of 2 m shall be maintained by the test technician performing the measurement. See Figure 2.

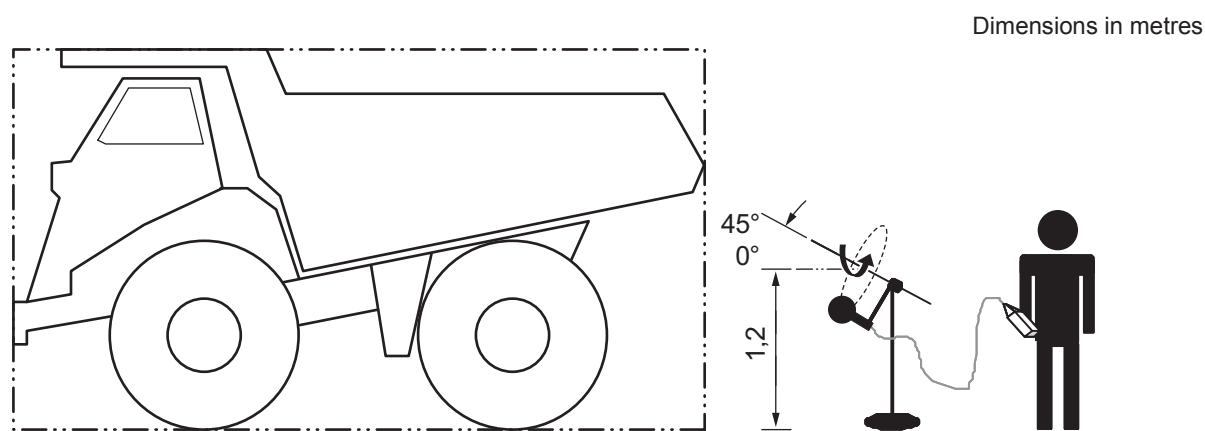

Figure 2 — Typical measurement setup for exterior alarm measurement

An approximate rotational rate of 2 r/min should be used to traverse the microphone along the 260 mm radius circle during the measurements.

An apparatus can be used to measure the sound along the perimeter of a $260\text{ mm} \pm 25\text{ mm}$ radius circle as shown in Figure 2. A description of how to build such an apparatus is given in Annex B.

7.3 Audible travel alarm and forward horn measurement

7.3.1 Reverse warning alarms — Exterior test

7.3.1.1 General

At test measurement locations 1 to 7, measure and record the maximum overall sound pressure level using either method 1 or 2, as specified below.

7.3.1.2 Method 1 — Fixed sound level alarms

— Alarm Off

Capture the maximum sound pressure level with the reversing alarm off and the engine at maximum governor engine speed (high idle).

— Alarm On

Capture the maximum sound pressure level with the reversing alarm on and the engine at low idle or with the engine switched off.

7.3.1.3 Method 2 — Self-adjusting sound level alarms

— Alarm Off

Capture the maximum sound pressure level with the reversing alarm off and the engine at maximum governor engine speed (high idle)

— Alarm On

Capture the maximum sound pressure level with the reversing alarm on and the engine at maximum governor engine speed (high idle).

7.3.2 Travel warning alarm measurement — Exterior test

7.3.2.1 General

At test measurement locations 5, 10 and 11, measure and record the maximum overall sound pressure level as specified below.

For machine types with their operator's station on the left-hand side of the machine (test measurement location 11), test measurements shall be taken and recorded at least at locations 5 and 10 for the maximum overall sound pressure level as defined below.

7.3.2.2 Method 1 — Fixed sound level alarms

— Alarm Off

Capture the maximum sound pressure level with the travel warning alarm off and the engine at maximum governor engine speed (high idle).

— Alarm On

Capture the maximum sound pressure level with the travel warning alarm on and engine at low idle or with the engine off.

7.3.2.3 Method 2 — Fixed sound level or self-adjusting sound level alarms

— Alarm Off

Capture the maximum sound pressure level with the travel alarm off and engine at maximum governor engine speed (high idle).

— Alarm On

Capture the maximum sound pressure level with the travel alarm on and engine at maximum governor engine speed (high idle).

If the travel alarm is also used as the primary reverse warning alarm, the tests and criteria given in 7.3.1 also apply.

7.3.3 Forward horn measurement — Exterior test

At test measurement location 8, measure and record the maximum overall sound pressure level as specified below.

— Horn Off

Capture the maximum sound pressure level with the forward horn off and the engine at maximum governor engine speed (high idle).

— **Horn On**

Capture the maximum sound pressure level with the forward horn on and the engine at low idle or with the engine switched off.

7.4 Reverse and travel warning alarm measurement for operator location

All sound measurements at the location of the operator (test measurement location 9), should be taken with the sound level meter set to the fast response time and with A weighting for a minimum of 1 min. The microphone should be positioned at the operator's ear level and moved from the far left to the far right and back, around the perimeter of a circle of radius $260 \text{ mm} \pm 25 \text{ mm}$. The height of the plane generated by this motion should be $655 \text{ mm} \pm 20 \text{ mm}$ above the SIP (seat index point) calculated in accordance with ISO 5353. The microphone may be hand-held by the test person in the operator seated position or swept in a circular path by a mechanical rotator positioned in the operator seated position. A rotational rate of $2 \text{ r/min} \pm 0,25 \text{ r/min}$ should be used. For more information on microphone orientation, see ISO 6396:2008, 6.3.1.

— **Alarm Off**

Capture the maximum sound pressure level with the reversing alarm off and the engine at maximum governor engine speed (high idle).

— **Alarm On**

Capture the maximum sound pressure level with the reversing alarm on and the engine at maximum governor engine speed (high idle).

Due to geometrical effects of the human head and shoulders on the sound field of the operator station, an individual meeting the requirements of 6.4.2 or, alternatively, an artificial acoustic head, should be used.

7.5 Criteria

7.5.1 General

For tests conducted in accordance with 7.2 to 7.4, the criteria given in 7.5.2 to 7.5.4 shall be met for each test measurement location and alarm type.

Sound pressure levels should be rounded to the nearest whole number as follows:

- values $< 0,5 \text{ dB}$ to the lower number;
- values $\geq 0,5 \text{ dB}$ to the higher number.

7.5.2 Reverse and travel warning alarm — Exterior test

7.5.2.1 General

The A-weighted sound pressure level determined at test measurement locations 1 to 7 for the alarm activation test shall meet the sound pressure level criterion given in 7.5.2.2 or 7.5.2.3, as appropriate.

7.5.2.2 Method 1 — Fixed sound level alarm

The recorded values from "Alarm On" shall be greater than or equal to the recorded values from "Alarm Off" at each test measurement location.

7.5.2.3 Method 2 — Self-adjusting sound level alarm

The recorded values from “Alarm On” shall be a minimum of 3 dB greater than the measured values from “Alarm Off” at each test measurement location.

7.5.3 Reverse warning alarm — Operator location test

The recorded values from “Alarm On” shall be no more than 3 dB greater than the measured values from “Alarm Off” at test measurement location 9.

7.5.4 Forward horn — Exterior test

The forward horn A-weighted sound pressure level shall exceed the A-weighted sound pressure level of the machine at maximum governor engine speed (high idle) by at least 10 dB at test measurement location 8.

NOTE Mandatory national and/or regional provisions could also apply to forward horns.

7.5.5 Travel warning alarm — Exterior test

7.5.5.1 General

The A-weighted sound pressure level determined at test measurement locations 5, 10 and 11 for the alarm activation test shall meet the sound pressure level criterion given in 7.5.5.2 or 7.5.5.3, as appropriate.

7.5.5.2 Method 1 — Fixed sound level alarm

The recorded values from “Alarm On” shall be greater than or equal to the recorded values from “Alarm Off” at each test measurement location.

7.5.5.3 Method 2 — Self-adjusting sound level alarm

The recorded values from “Alarm On” shall be a minimum of 3 dB greater than the measured values from “Alarm Off” at each test measurement location.

8 Alarm activation requirements

8.1 Reverse warning alarm

The reverse warning alarm shall be automatically activated upon the machine being activated for travelling in reverse. For machines with two independent propel drive systems, e.g. hydrostatic and hydraulic propel drive systems, the reverse warning alarm does not need to be activated and begin sounding until both propel drive systems are activated for reverse travel. Slow reverse movement is allowable without the reverse warning alarm sounding on some types of travel control systems, e.g. mechanical controls, based on a risk assessment having been performed. The reverse warning alarm shall continue to sound until the machine is deactivated for travelling in reverse.

8.2 Forward horn

The forward horn shall be manually activated by a dedicated control and continue to sound as long as the operator activates the control within the limits of the horn itself.

If the horn is to be used for a security alarm system for the machine, the duty cycle should be set by the horn manufacturer so that the alarm will not permanently damage the horn.

8.3 Travel warning alarm

Travel warning alarms shall be automatically activated upon activation of the machine travel control. For machines with two independent propel drive systems, e.g. hydrostatic and hydraulic, the travel warning alarm need not be activated and begin sounding until both propel drive systems are activated for travel. Slow movement is allowable without the travel warning alarm sounding on some types of travel control systems, e.g. mechanical controls.

The travel warning alarm signal may have a time limit. This time limit can be either automatic or manual with the following provisions.

- The alarm signal shall be active for at least 5 s.
- The alarm system shall automatically return to normal operation status when the travel control is in neutral or deactivated.
- The alarm shall automatically return to normal operation status when the machine is shut down or turned off (i.e. on machine restart, the alarm will sound during machine travel movement under power).
- The manual control for shutting off the alarm after sounding the required time, if provided, shall be guarded, located or interlocked to avoid unintended activation. This manual control shall be labelled to indicate its purpose and instructions on its use shall be provided in the operator's manual.

9 Information to be reported

Annex A gives the typical format of a test worksheet using this International Standard. The information recorded therein should include the following:

- machine type and serial number (e.g. PIN) and attachment tested;
- engine idle and maximum governor speed (high idle);
- audible travel alarm(s) and forward horn, manufacturer(s) and model(s);
- measurement levels for all test measurement locations for “alarm on” and “alarm off”;
- observations of environmental conditions (temperature, wind speed etc.);
- test date;
- persons performing testing and analysis;
- test equipment (see ISO 6393:2008, Clause 9).

Annex A (informative)

Example test worksheet

This test sheet is given as an example and might need to be modified to meet the manufacturer's needs.

ISO 9533 alarm test worksheet

Alarm description			
	Reverse	Forward	Travel
Manufacturer			
Model no.			
Output level			
Type			

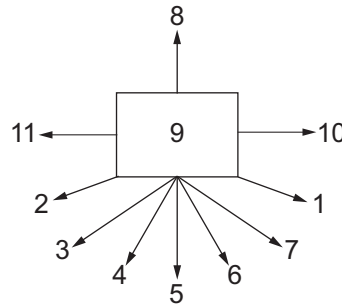

Machine description	
Model	
S/N	
Engine r/min	
Cooling fan	

A-weighted decibels:

- Type A: 112 dB
- Type B: 107 dB
- Type C: 97 dB
- Type D: 87 dB
- Type E: 77 dB
- Type F: Other

Alarm test method used:

- 1 – Alarm ON at low idle or engine off
- 2 – Alarm ON at high idle
- 1/3rd octave band method

Location	Alarm	Coordinates and directions m					As measured from	Sound level A-weighted dB		
								Alarm ON	Alarm OFF	Difference
1	Reverse	0,7	Right	0,7	Rear	Corner				
2	Reverse	0,7	Left	0,7	Rear	Corner				
3	Reverse	4,9	Left	4,9	Rear	Rear centre				
4	Reverse	2,7	Left	6,5	Rear	Rear centre				
5	Reverse and travel	0,0	Centre	7,0	Rear	Rear centre				
6	Reverse	2,7	Right	6,5	Rear	Rear centre				
7	Reverse	4,9	Right	4,9	Rear	Rear centre				
8	Forward and travel	0,0	Centre	7,0	Front	Front centre				
9	Reverse	Location of operator (260 mm radius) Closed cab/open canopy				Ear height				
10	Travel	0,0	Centre	7,0	Right	Right side				
11	Travel	0,0	Centre	7,0	Left	Left side				

- Reverse alarm exterior Method 1: for locations 1–7, an “Alarm On” – “Alarm Off” difference of ≥ 0 dB.
Method 2: for locations 1–7, an “Alarm On” – “Alarm Off” difference of ≥ 3 dB.
- Travel alarm exterior Method 1: for locations 5, 8, 10 and 11, an “Alarm On” – “Alarm Off” difference of ≥ 0 dB.
Method 2: for locations 5, 8, 10 and 11, an “Alarm On” – “Alarm Off” difference of ≥ 3 dB.
- Horn exterior For location 8, an “Alarm On” – “Alarm Off” difference of ≥ 10 dB.
- Reverse alarm interior For location 9, an “Alarm On” – “Alarm Off” difference of ≤ 3 dB.

Remarks: _____

Annex B (informative)

Apparatus for exterior alarm measurement

One effective apparatus for this measurement could be shaped as shown below in Figure B.1. This section is placed on a stand with the microphone on the far left side and rotated as described in 7.2 during the measurement.

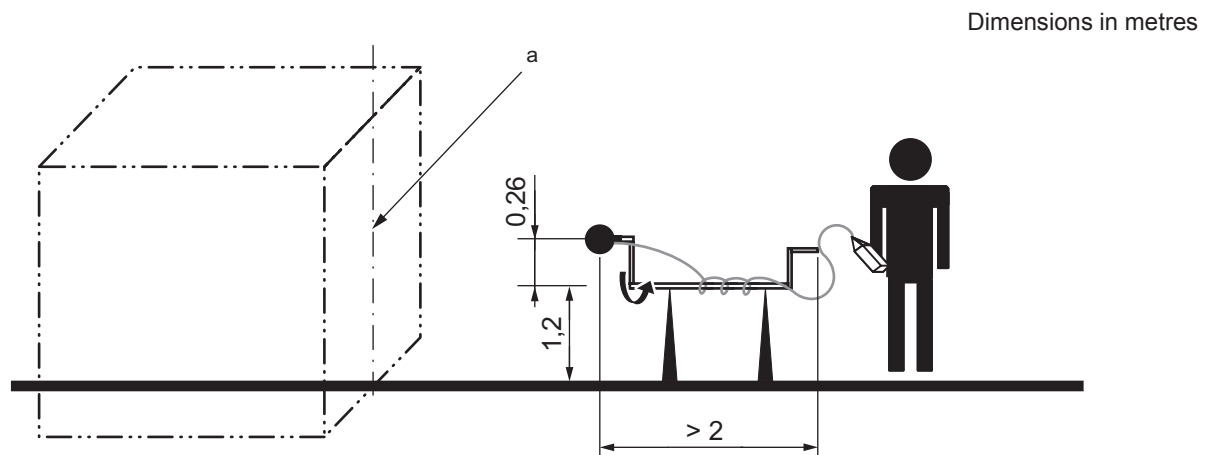

^a Centre line of the machine reference box (MRB).

Figure B.1 — Electrical conduit apparatus for measurement

Annex C (informative)

1/3rd octave band test method for reverse and travel warning alarms

C.1 General

If the frequency and/or temporal distribution of the alarm sound clearly differ from the corresponding characteristics of the ambient noise, a lower sound-pressure level of the signal can be sufficient. For some applications, the use of 1/3rd octave band analysis could have some advantage in evaluating the audibility of the reverse warning alarm sound within the ambient noise of an operating machine.

NOTE 1 See ISO 7731 for more information and guidance.

NOTE 2 A sound level meter or equivalent equipment capable of measuring 1/3rd octave levels is required for this test method.

C.2 Test procedure

C.2.1 Measurement setup

With the sound level meter capable of measuring 1/3rd octave bands, set the meter to “Fast” response time and capture maximum A-weighted sound pressure levels for each 1/3rd octave band. See 7.3.1 for details on the measurement setup.

C.2.2 1/3rd octave measurement

At test measurement locations 1 to 7 for reverse warning alarms and at locations 5, 10 and 11 for travel warning alarms as defined in Figure 1, measure and record the maximum 1/3rd octave A-scaled sound pressure level for the bands identified above as follows.

C.2.3 Fixed sound level or self-adjusting sound level alarm

— Alarm Off

Maximum sound pressure level with the reversing alarm off and engine at maximum no-load speed.

— Alarm On

Maximum sound pressure level with the reversing alarm on and engine at maximum no-load speed.

C.3 Criteria — 1/3rd Octave — Fixed sound level or self-adjusting sound level alarm

At test measurement locations 1 to 7 for reverse warning alarms and at locations 5, 10 and 11 for travel warning alarms, identify the 1/3rd octave band(s) between 500 Hz and 4 000 Hz that contain the dominant sound of the alarm. Dominant 1/3 octave bands are those within 6 dB of the highest level 1/3rd octave band.

The recorded values from “Alarm On” shall be +13 dB greater than the recorded values from “Alarm Off” in one or more of the identified dominant 1/3rd octave band(s) at that location.

Bibliography

- [1] ISO 3744, *Acoustics — Determination of sound power levels and sound energy levels of noise sources using sound pressure — Engineering methods for an essentially free field over a reflecting plane*
- [2] ISO 5006, *Earth-moving machinery — Operator's field of view — Test method and performance criteria*
- [3] ISO 5353, *Earth-moving machinery, and tractors and machinery for agriculture and forestry — Seat index point*
- [4] ISO 6393:2008, *Earth-moving machinery — Determination of sound power level — Stationery test conditions*
- [5] ISO 6396:2008, *Earth-moving machinery — Determination of emission sound pressure level at operator's position — Dynamic test conditions*
- [6] ISO 7731, *Ergonomics — Danger signals for public and work areas — Auditory danger signals*

British Standards Institution (BSI)

BSI is the national body responsible for preparing British Standards and other standards-related publications, information and services.

BSI is incorporated by Royal Charter. British Standards and other standardization products are published by BSI Standards Limited.

About us

We bring together business, industry, government, consumers, innovators and others to shape their combined experience and expertise into standards-based solutions.

The knowledge embodied in our standards has been carefully assembled in a dependable format and refined through our open consultation process. Organizations of all sizes and across all sectors choose standards to help them achieve their goals.

Information on standards

We can provide you with the knowledge that your organization needs to succeed. Find out more about British Standards by visiting our website at bsigroup.com/standards or contacting our Customer Services team or Knowledge Centre.

Buying standards

You can buy and download PDF versions of BSI publications, including British and adopted European and international standards, through our website at bsigroup.com/shop, where hard copies can also be purchased.

If you need international and foreign standards from other Standards Development Organizations, hard copies can be ordered from our Customer Services team.

Subscriptions

Our range of subscription services are designed to make using standards easier for you. For further information on our subscription products go to bsigroup.com/subscriptions.

With **British Standards Online (BSOL)** you'll have instant access to over 55,000 British and adopted European and international standards from your desktop. It's available 24/7 and is refreshed daily so you'll always be up to date.

You can keep in touch with standards developments and receive substantial discounts on the purchase price of standards, both in single copy and subscription format, by becoming a **BSI Subscribing Member**.

PLUS is an updating service exclusive to BSI Subscribing Members. You will automatically receive the latest hard copy of your standards when they're revised or replaced.

To find out more about becoming a BSI Subscribing Member and the benefits of membership, please visit bsigroup.com/shop.

With a **Multi-User Network Licence (MUNL)** you are able to host standards publications on your intranet. Licences can cover as few or as many users as you wish. With updates supplied as soon as they're available, you can be sure your documentation is current. For further information, email bsmusales@bsigroup.com.

BSI Group Headquarters

389 Chiswick High Road London W4 4AL UK



Revisions

Our British Standards and other publications are updated by amendment or revision.

We continually improve the quality of our products and services to benefit your business. If you find an inaccuracy or ambiguity within a British Standard or other BSI publication please inform the Knowledge Centre.

Copyright

All the data, software and documentation set out in all British Standards and other BSI publications are the property of and copyrighted by BSI, or some person or entity that owns copyright in the information used (such as the international standardization bodies) and has formally licensed such information to BSI for commercial publication and use. Except as permitted under the Copyright, Designs and Patents Act 1988 no extract may be reproduced, stored in a retrieval system or transmitted in any form or by any means – electronic, photocopying, recording or otherwise – without prior written permission from BSI. Details and advice can be obtained from the Copyright & Licensing Department.

Useful Contacts:

Customer Services

Tel: +44 845 086 9001

Email (orders): orders@bsigroup.com

Email (enquiries): cservices@bsigroup.com

Subscriptions

Tel: +44 845 086 9001

Email: subscriptions@bsigroup.com

Knowledge Centre

Tel: +44 20 8996 7004

Email: knowledgecentre@bsigroup.com

Copyright & Licensing

Tel: +44 20 8996 7070

Email: copyright@bsigroup.com

...making excellence a habit.™