

BS ISO 9465:2012



BSI Standards Publication

Alpine ski-bindings — Lateral release under impact loading — Test method

bsi.

...making excellence a habit.™

National foreword

This British Standard is the UK implementation of ISO 9465:2012.

The UK participation in its preparation was entrusted to Technical Committee SW/136/7, Snowsports equipment.

A list of organizations represented on this committee can be obtained on request to its secretary.

This publication does not purport to include all the necessary provisions of a contract. Users are responsible for its correct application.

© The British Standards Institution 2012. Published by BSI Standards Limited 2012

ISBN 978 0 580 71577 8

ICS 97.220.20

Compliance with a British Standard cannot confer immunity from legal obligations.

This British Standard was published under the authority of the Standards Policy and Strategy Committee on 30 June 2012.

Amendments issued since publication

Date	Text affected
------	---------------

INTERNATIONAL
STANDARD

BS ISO 9465:2012

ISO
9465

Second edition
2012-06-15

**Alpine ski-bindings — Lateral release
under impact loading — Test method**

*Fixations de skis alpins — Déclenchement latéral sous choc —
Méthode d'essai*



Reference number
ISO 9465:2012(E)

© ISO 2012



COPYRIGHT PROTECTED DOCUMENT

© ISO 2012

All rights reserved. Unless otherwise specified, no part of this publication may be reproduced or utilized in any form or by any means, electronic or mechanical, including photocopying and microfilm, without permission in writing from either ISO at the address below or ISO's member body in the country of the requester.

ISO copyright office
Case postale 56 • CH-1211 Geneva 20
Tel. + 41 22 749 01 11
Fax + 41 22 749 09 47
E-mail copyright@iso.org
Web www.iso.org

Published in Switzerland

Foreword

ISO (the International Organization for Standardization) is a worldwide federation of national standards bodies (ISO member bodies). The work of preparing International Standards is normally carried out through ISO technical committees. Each member body interested in a subject for which a technical committee has been established has the right to be represented on that committee. International organizations, governmental and non-governmental, in liaison with ISO, also take part in the work. ISO collaborates closely with the International Electrotechnical Commission (IEC) on all matters of electrotechnical standardization.

International Standards are drafted in accordance with the rules given in the ISO/IEC Directives, Part 2.

The main task of technical committees is to prepare International Standards. Draft International Standards adopted by the technical committees are circulated to the member bodies for voting. Publication as an International Standard requires approval by at least 75 % of the member bodies casting a vote.

Attention is drawn to the possibility that some of the elements of this document may be the subject of patent rights. ISO shall not be held responsible for identifying any or all such patent rights.

ISO 9465 was prepared by Technical Committee ISO/TC 83, *Sports and recreational equipment*, Subcommittee SC 4, *Snowsports equipment*.

This second edition cancels and replaces the first edition (ISO 9465:1991), which has been technically revised.

Introduction

This International Standard is one of a series dealing with the safety of ski-bindings. The other current International Standards are ISO 8061 and ISO 9462.

National standards, complying with legal regulations, may be more extensive, for instance covering combined loading and ski deflection. International Standards are being prepared that address these aspects. To verify the safety of ski-bindings, it is necessary to use all International Standards of the series and additionally the national standards covering those aspects which are not yet standardized internationally.

The release and retention functions of ski-bindings are multifaceted and complex. The functions involve combinations of static and dynamic loading in varied release directions of the boot relative to the ski. This impulsive test method evaluates an important ski-binding function, but it should not be interpreted as conclusively evaluating the binding impulse release behaviour in general. The test evaluates the release and retention function of the binding in a single mode of binding release; other static and dynamic retention and release tests are not excluded by this standard test.

Alpine ski-bindings — Lateral release under impact loading — Test method

1 Scope

This International Standard defines an impact test for establishing the maximum impulse for retention of a test ski on the test sole in the lateral direction.

The test provides a measure of the release/retention boundary for lateral release of a ski-binding for adults (type A according to ISO 9462) at a particular ski-binding setting.

The test method is designed to simulate the lateral impulsive loading during skiing located at the front part of the ski. The test permits the evaluation of a ski-binding's release and retention properties under expected loading rates. The test permits comparison of the release caused by lateral impulse to the ski for different binding system designs.

2 Normative references

The following referenced documents are indispensable for the application of this document. For dated references, only the edition cited applies. For undated references, the latest edition of the referenced document (including any amendments) applies.

ISO 9462:—¹⁾, *Alpine ski-bindings — Requirements and test methods*

ISO 9838, *Alpine and touring ski-bindings — Test soles for ski-binding tests*

3 Terms and definitions

For the purposes of this document, the following terms and definitions apply.

3.1

contact material

material interface between the pendulum contact tip and the side wall of the test ski

NOTE The contact material specification in conjunction with the pendulum release angle determines the duration and the magnitude of the impulse force during the impact test.

3.2

impact force

force, the duration of application of which is short compared with the response time of the ski-binding/pendulum system

1) To be published.

3.3

impulse

product of mass and velocity of the impact parts

NOTE According to Newton's second law of motion:

$$m \times v = F \times \Delta t$$

where

F is the force;

Δt is the period of time of the contact of force;

m is the mass;

v is the velocity of the impact.

3.4

test ski

aluminium U-shaped channel

NOTE 1 The tip and the tail of the test ski refer to the extreme points along the length of the channel in front of and behind the ski-binding that is mounted on the channel.

NOTE 2 The test ski is described in 4.2.1.

3.5

test sole

sole in accordance with ISO 9838, backed by a steel plate

NOTE The test sole is described in 4.2.2.

3.6

goniometer

instrument used to measure the angle of the pendulum shaft relative to the vertical equilibrium axis at the pendulum bearing

3.7

pendulum shaft

long, circular cylinder connecting the pendulum block to the pendulum bearing

3.8

contact tip

steel hemispherical tip on the pendulum bearing

3.9

pendulum block

rigid mass on the free end of the pendulum shaft, upon which the contact tip is rigidly mounted

3.10

impact location

point on the test ski side wall where the impact occurs

3.11

binding release

condition whereby the binding has released the test ski from the test boot

NOTE Binding release is defined by either

- a) the test ski separating completely from the test boot, or

- b) the test ski being offset from the boot toe by 5 mm or more and no visible recentering of the test ski on the test boot being observed for a period of up to 10 s,

when an impact test is carried out.

3.12

pendulum tower

structure supporting the pendulum bearing, shaft and block

3.13

pendulum release angle

θ_{rel}

angle between the pendulum shaft and the vertical when the pendulum shaft is released from the rest

3.14

pendulum bearing

bearing mounted on the pendulum tower, supporting the pendulum shaft

3.15

sole support

structure required to hold and position the test sole rigidly

3.16

pendulum rebound angle

maximum angle between the pendulum shaft and the vertical, following impact of the contact tip and contact material during a test

3.17

percentage rebound

percentage rebound is given by the following relative value, R

$$R = \frac{[1 - \cos(\theta_{reb})]}{[1 - \cos(\theta_{rel})]} \times 100, \text{ in } \%$$

where

θ_{reb} is the pendulum rebound angle;

θ_{rel} is the pendulum release angle.

4 Test method

4.1 Principle

The ski-binding is mounted on a standard test ski. The ski release binding is adjusted for a static release in accordance with ISO 9462:—, 6.4. The release setting is recorded.

The test ski is mounted on the test sole. The sole is rigidly fixed during testing.

The contact material between the test ski and the pendulum impact is as specified in 4.2.7.

The standard pendulum applies impulsive loading to the test ski at the lowest point of the pendulum arc.

The pendulum pivot friction and the contact material are evaluated according to 4.2.6.2 and 4.2.7.3 prior to and following the test of ski release bindings. Records of the evaluations are maintained.

The pendulum release angle is decreased from a value sufficient to guarantee release of the binding following a single impact of the test ski until the maximum angle for which retention of the binding is obtained. The release angle causing the ski-binding to release at the release/retention boundary is recorded.

4.2 Apparatus

4.2.1 Test ski

The test ski is a U-shaped channel section of aluminium with the following dimensions (see Table 1):

Table 1 — Dimensions of the test ski

Dimensions in millimetres

	USA size	European size
Length	500 ± 2	500 ± 2
Width	62 ± 2	60
Height	35 ± 5	40
Wall thickness	3,6 ± 0,6	3

The toe of the boot sole shall be located (75 ± 1) mm from the tip of the test ski. The binding being tested can either be mounted directly on the test ski or on an original ski piece (ski interface), which then couples with the test ski. The total mass of the test ski and the ski interface shall not exceed 1 200 g without the binding, and the length of the ski interface shall be within (700 ± 10) mm.

4.2.2 Test sole

The test sole shall conform to ISO 9838 except when the binding manufacturer specifies modifications for the sole design. The test sole is backed by a steel plate (216 ± 4) mm × (57 ± 3) mm × (10 ± 1) mm. The test sole is bolted to the plate which is used for rigidly holding the test sole to the support.

4.2.3 Pendulum tower

4.2.3.1 The pendulum tower shall be sufficiently rigid that it does not influence the impact response of the test ski.

4.2.3.2 One configuration for the tower consists of a structure of four steel plates welded into the form of a hollow, square cylinder with external square cross-section dimensions (254 ± 2) mm × (254 ± 2) mm and length (1 220 ± 2) mm. The plate thickness is (9,5 ± 0,5) mm. An additional steel plate of dimensions (330 ± 2) mm × (330 ± 2) mm × (25 ± 1) mm is welded to the bottom of the cylinder, and a plate of dimensions (305 ± 2) mm × (381 ± 2) mm × (13 ± 0,5) mm is welded to the top. The latter two plate surfaces are approximately parallel and perpendicular to the long axis of the cylinder. The base plate is drilled to allow the tower to be bolted rigidly to a concrete foundation in four or more places. The top plate forms a nearly rigid foundation for the pendulum bearing system.

4.2.3.3 The pendulum bearing base shall allow adjustment of the pendulum height and position by movement of the pendulum bearing in the plane of the pendulum motion. Height adjustment is required in order to guarantee proper impact of the contact tip with the impact location for bindings of different heights. Adjustment of the horizontal position is required in order to guarantee that impact occurs at the bottom of the pendulum arc.

4.2.4 Pendulum shaft

4.2.4.1 The pendulum shaft is a circular steel cylinder of mass (2,3 ± 0,1) kg. The shaft is (1 000 ± 2) mm long with an outer diameter of (40 ± 0,1) mm and an inner diameter of (35 ± 0,1) mm. The shaft is mounted in the pendulum bearing so that it swings in a single vertical plane normal to the test ski.

4.2.4.2 The pendulum shaft is rigidly secured to the pendulum block on the end of the shaft furthest from the pendulum bearing. The pendulum block mass is (3 ± 0,1) kg. The contact tip has a hardness of 45 HRC and a diameter of (10 ± 0,5) mm and is rigidly fixed to the pendulum block.

4.2.4.3 The length from the centre of the pendulum bearing to the point of impact on the contact tip is $(1\,025 \pm 5)$ mm.

4.2.5 Test sole support

4.2.5.1 The test sole support holds the test sole rigidly.

4.2.5.2 The support structure is constructed of heavy steel plate and is mounted in a concrete foundation in order to maintain rigidity during impact.

4.2.5.3 The support adjustment allows movement of the test sole longitudinally for positioning the impact location relative to the contact tip.

4.2.6 Pendulum bearing

4.2.6.1 A roller bearing with an inner diameter of at least $(12 \pm 0,5)$ mm supports the pendulum shaft on the pendulum tower.

4.2.6.2 The pendulum bearing function is evaluated by a free oscillation test of the complete pendulum tower, shaft and block systems. No test ski or boot is involved. The pendulum is released from rest at a pendulum release angle of $(12 \pm 0,5)^\circ$. The pendulum shall move through at least 60 complete oscillations before coming to rest at the vertical equilibrium. The number of oscillations is recorded.

4.2.7 Contact material specification

4.2.7.1 The contact material is chosen to produce a loading separation time from 20 ms to 100 ms at the toe of the test sole, which is similar to those measured during skiing.

4.2.7.2 The contact material shall be neoprene with shore A hardness from 60 to 65 and dimensions of $(20 \pm 0,2)$ mm \times $(20 \pm 0,2)$ mm \times (7 ± 1) mm at 23 °C. Contact materials constructed of metal, wood, acrylic plastic and other hard materials are specifically excluded, as well as contact materials from very soft materials that give long loading durations or large dissipation of energy.

4.2.7.3 The contact material shall be qualified for application through a resiliency test using the percentage rebound R defined in 3.17. The qualification test requires that the average percentage rebound lie between 34 % and 39 % ($7^\circ \pm 1^\circ$) for a pendulum release angle of $(11 \pm 1)^\circ$ during impact of the contact material mounted on the material test fixture. The average percentage rebound is the average of three R values measured in consecutive tests. Variations in R of 5 % or more from the mean value in a single test indicate a defective test procedure or contact material. Such a test cannot be used to qualify the contact material. The pendulum shaft, block and bearing system used during the impact test are also used for qualification of the contact material.

4.2.7.4 The contact material shall qualify before each test series. All qualification tests shall be recorded. Where the contact material fails to qualify following a test series, all tests of that series shall be discarded.

4.2.7.5 The centre of the contact material square surface is positioned at the impact location, which is (10 ± 1) mm from the ski tip. The pendulum shall contact the test ski perpendicular to the Z-X plane.

4.2.8 Contact material test fixture

The contact material test fixture allows the contact material and test ski to be supported rigidly during qualification of the contact material.

4.2.9 Instrumentation

4.2.9.1 Measurements

The rotation of the pendulum shaft is measured with a goniometer, measuring the pendulum release angle and the pendulum rebound angle.

4.2.9.2 Range

The range of the goniometer shall be sufficient for the entire rotation ranges for the tests.

4.2.9.3 Accuracy

The goniometer error shall be less than $\pm 0,5^\circ$ over the range of measurement.

4.2.9.4 Repeatability

The goniometer angle measurements shall be repeatable to $\pm 0,5^\circ$ over the entire range of application of the pendulum.

4.3 Procedure

4.3.1 Mount the ski-binding system on the test ski according to the manufacturer's specifications and according to the specification for the position of the binding on the test ski in 4.2.1. See the example given in Figure A.1, detail Y. Clean the test sole surfaces and interfaces with an appropriate solvent unless otherwise specified by environmental test procedures.

4.3.2 Conduct all tests at room temperature, $(20 \pm 5)^\circ\text{C}$. Conduct all system qualification tests at the temperature of impact testing $\pm 2^\circ\text{C}$.

4.3.3 The release moments of the functional unit ski-binding and test sole shall be adjusted in accordance with ISO 9462 (see requirements for energy absorption). The static release moments shall be measured 5 times with a test sole (see 4.2.2) of length 305 mm. In the release direction +Mz, a mean value shall be derived from five measurements.

4.3.4 Release the ski-binding system quasi-statically five times prior to the impact test if this has not been done before.

4.3.5 The first pendulum release angle shall be sufficiently large to guarantee binding release and complete separation of the test ski from the sole. Reinsert the sole in the binding after each impact test. Reduce the pendulum release angle in subsequent impact tests until an angle for which the binding is at the limit between release (as defined in 3.11) and retention is obtained. Repeat the test three times.

4.3.6 Record the pendulum release angles for which the binding is at the limit between release and retention.

4.4 Test report

The test report shall include:

- a) the ski-binding manufacturer and model;
- b) the condition of the ski-binding (new, used, damaged, etc.);
- c) the date of the test;
- d) the temperatures of the test apparatus and test binding during the qualification;
- e) the specification of the test sole (ISO 9838 and this International Standard, i.e. ISO 9465);

- f) the quasi-static release value, in N·m;
- g) pendulum release angles, as specified in 4.3.6, for the three release tests;
- h) qualification test data for the pendulum bearing as in 4.2.6.2 and for the contact material as in 4.2.7.2 for each test series and contact material;
- i) dimensions of the test ski (USA size, European size or ski interface).

Annex A (informative)

Pendulum

Figure A.1 shows the dimensions of the pendulum.

Dimensions in millimetres

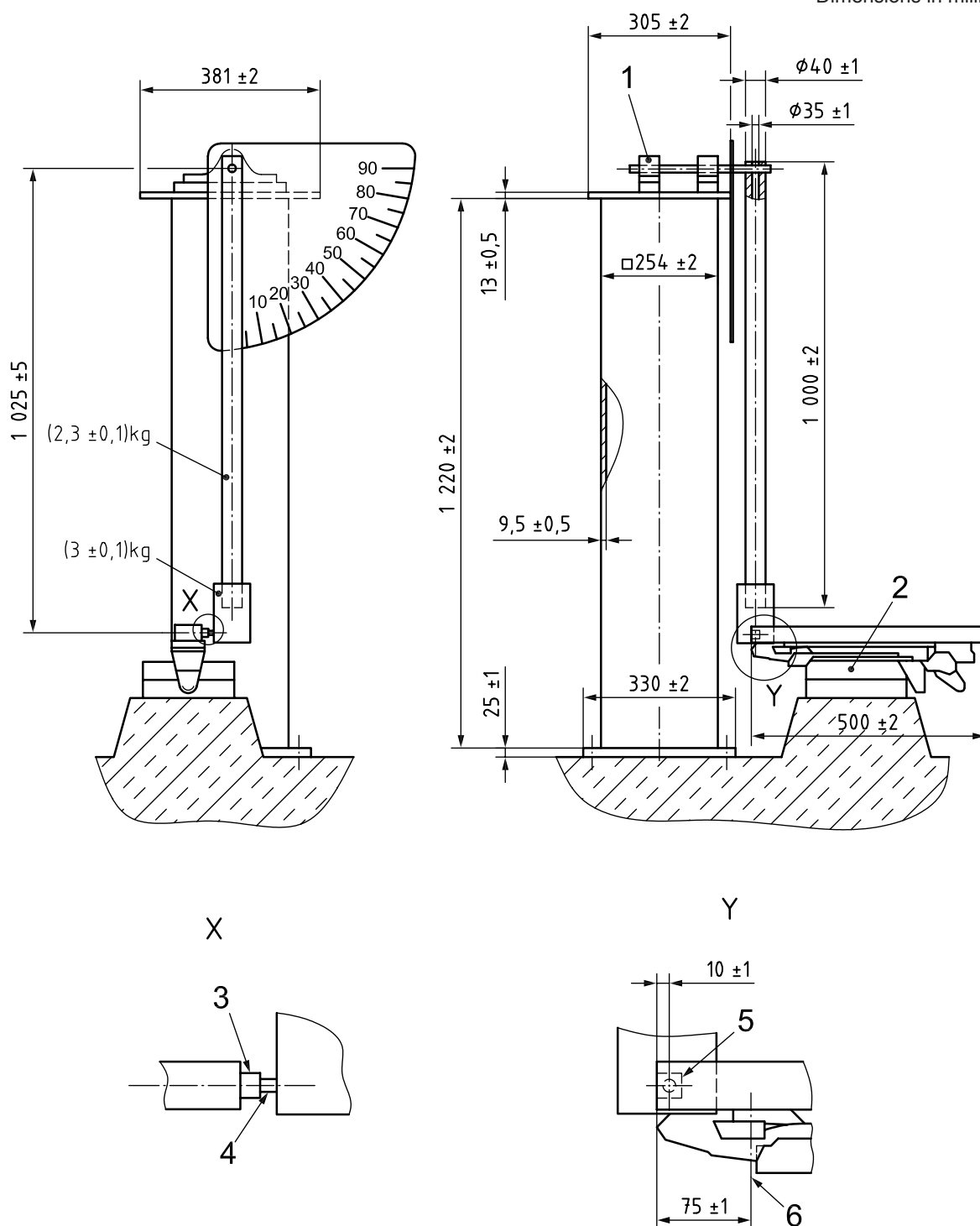

Key

- 1 pendulum bearing horizontal and vertical adjustment
- 2 boot support longitudinal adjustment
- 3 contact material
- 4 contact tip $\phi 10$, 45 HRC
- 5 contact material (chloropren-caoutchouc)
- 6 boot tip

Figure A.1 — Pendulum

Bibliography

- [1] ISO 8061, *Alpine ski-bindings — Selection of release torque values*

British Standards Institution (BSI)

BSI is the national body responsible for preparing British Standards and other standards-related publications, information and services.

BSI is incorporated by Royal Charter. British Standards and other standardization products are published by BSI Standards Limited.

About us

We bring together business, industry, government, consumers, innovators and others to shape their combined experience and expertise into standards-based solutions.

The knowledge embodied in our standards has been carefully assembled in a dependable format and refined through our open consultation process. Organizations of all sizes and across all sectors choose standards to help them achieve their goals.

Information on standards

We can provide you with the knowledge that your organization needs to succeed. Find out more about British Standards by visiting our website at bsigroup.com/standards or contacting our Customer Services team or Knowledge Centre.

Buying standards

You can buy and download PDF versions of BSI publications, including British and adopted European and international standards, through our website at bsigroup.com/shop, where hard copies can also be purchased.

If you need international and foreign standards from other Standards Development Organizations, hard copies can be ordered from our Customer Services team.

Subscriptions

Our range of subscription services are designed to make using standards easier for you. For further information on our subscription products go to bsigroup.com/subscriptions.

With **British Standards Online (BSOL)** you'll have instant access to over 55,000 British and adopted European and international standards from your desktop. It's available 24/7 and is refreshed daily so you'll always be up to date.

You can keep in touch with standards developments and receive substantial discounts on the purchase price of standards, both in single copy and subscription format, by becoming a **BSI Subscribing Member**.

PLUS is an updating service exclusive to BSI Subscribing Members. You will automatically receive the latest hard copy of your standards when they're revised or replaced.

To find out more about becoming a BSI Subscribing Member and the benefits of membership, please visit bsigroup.com/shop.

With a **Multi-User Network Licence (MUNL)** you are able to host standards publications on your intranet. Licences can cover as few or as many users as you wish. With updates supplied as soon as they're available, you can be sure your documentation is current. For further information, email bsmusales@bsigroup.com.

BSI Group Headquarters

389 Chiswick High Road London W4 4AL UK

Revisions

Our British Standards and other publications are updated by amendment or revision.

We continually improve the quality of our products and services to benefit your business. If you find an inaccuracy or ambiguity within a British Standard or other BSI publication please inform the Knowledge Centre.

Copyright

All the data, software and documentation set out in all British Standards and other BSI publications are the property of and copyrighted by BSI, or some person or entity that owns copyright in the information used (such as the international standardization bodies) and has formally licensed such information to BSI for commercial publication and use. Except as permitted under the Copyright, Designs and Patents Act 1988 no extract may be reproduced, stored in a retrieval system or transmitted in any form or by any means – electronic, photocopying, recording or otherwise – without prior written permission from BSI. Details and advice can be obtained from the Copyright & Licensing Department.

Useful Contacts:

Customer Services

Tel: +44 845 086 9001

Email (orders): orders@bsigroup.com

Email (enquiries): cservices@bsigroup.com

Subscriptions

Tel: +44 845 086 9001

Email: subscriptions@bsigroup.com

Knowledge Centre

Tel: +44 20 8996 7004

Email: knowledgecentre@bsigroup.com

Copyright & Licensing

Tel: +44 20 8996 7070

Email: copyright@bsigroup.com



...making excellence a habit.™