

BS ISO 9448-5:2013



BSI Standards Publication

# Tools for pressing — Guide bushes

Part 5: Form D, ball cage bushes, headed, type 1

**bsi.**

...making excellence a habit.™

**National foreword**

This British Standard is the UK implementation of ISO 9448-5:2013. It supersedes BS 7568-21:1992 (ISO 9448-5:1991) which is withdrawn.

The UK participation in its preparation was entrusted to Technical Committee MTE/12, Tools for pressing and moulding.

A list of organizations represented on this committee can be obtained on request to its secretary.

This publication does not purport to include all the necessary provisions of a contract. Users are responsible for its correct application.

© The British Standards Institution 2014.  
Published by BSI Standards Limited 2014

ISBN 978 0 580 77011 1  
ICS 25.120.10

**Compliance with a British Standard cannot confer immunity from legal obligations.**

This British Standard was published under the authority of the Standards Policy and Strategy Committee on 31 January 2014.

**Amendments/corrigenda issued since publication**

Date	Text affected
------	---------------

---

INTERNATIONAL  
STANDARD

**ISO**  
**9448-5**

Second edition  
2013-12-15

---

---

**Tools for pressing — Guide bushes —**  
**Part 5:**  
**Form D, ball cage bushes, headed, type**  
**1**

*Outillage de presse — Bagues de guidage —*

*Partie 5: Forme D, bagues à collerette pour guidage à billes, type 1*



Reference number  
ISO 9448-5:2013(E)

© ISO 2013



**COPYRIGHT PROTECTED DOCUMENT**

© ISO 2013

All rights reserved. Unless otherwise specified, no part of this publication may be reproduced or utilized otherwise in any form or by any means, electronic or mechanical, including photocopying, or posting on the internet or an intranet, without prior written permission. Permission can be requested from either ISO at the address below or ISO's member body in the country of the requester.

ISO copyright office  
Case postale 56 • CH-1211 Geneva 20  
Tel. + 41 22 749 01 11  
Fax + 41 22 749 09 47  
E-mail [copyright@iso.org](mailto:copyright@iso.org)  
Web [www.iso.org](http://www.iso.org)

Published in Switzerland

# Contents

	Page
Foreword .....	iv
<b>1 Scope .....</b>	<b>1</b>
<b>2 Dimensions .....</b>	<b>1</b>
<b>3 Material .....</b>	<b>3</b>
<b>4 Designation .....</b>	<b>3</b>
<b>Bibliography .....</b>	<b>4</b>

## Foreword

ISO (the International Organization for Standardization) is a worldwide federation of national standards bodies (ISO member bodies). The work of preparing International Standards is normally carried out through ISO technical committees. Each member body interested in a subject for which a technical committee has been established has the right to be represented on that committee. International organizations, governmental and non-governmental, in liaison with ISO, also take part in the work. ISO collaborates closely with the International Electrotechnical Commission (IEC) on all matters of electrotechnical standardization.

The procedures used to develop this document and those intended for its further maintenance are described in the ISO/IEC Directives, Part 1. In particular the different approval criteria needed for the different types of ISO documents should be noted. This document was drafted in accordance with the editorial rules of the ISO/IEC Directives, Part 2. [www.iso.org/directives](http://www.iso.org/directives)

Attention is drawn to the possibility that some of the elements of this document may be the subject of patent rights. ISO shall not be held responsible for identifying any or all such patent rights. Details of any patent rights identified during the development of the document will be in the Introduction and/or on the ISO list of patent declarations received. [www.iso.org/patents](http://www.iso.org/patents)

Any trade name used in this document is information given for the convenience of users and does not constitute an endorsement.

For an explanation on the meaning of ISO specific terms and expressions related to conformity assessment, as well as information about ISO's adherence to the WTO principles in the Technical Barriers to Trade (TBT) see the following URL: [Foreword - Supplementary information](#)

The committee responsible for this document is ISO/TC 29, *Small tools*, Subcommittee SC 8, *Tools for pressing and moulding*.

This second edition results from the reinstatement of ISO 9448-5:1991, which was withdrawn in 2006 and with which it is technically identical.

ISO 9448 consists of the following parts, under the general title *Tools for pressing — Guide bushes*:

- Part 1: *Forms*
- Part 2: *Form A, gliding bushes, plain, type 1*
- Part 3: *Form B, ball cage bushes, plain, type 1*
- Part 4: *Form C, gliding bushes, headed, type 1*
- Part 5: *Form D, ball cage bushes, headed, type 1*
- Part 6: *Form E, gliding bushes, flanged, type 1*
- Part 7: *Form F, ball cage bushes, flanged, type 1*
- Part 8: *Form G, gliding bushes, stepped, type 1*
- Part 9: *Form B, ball cage bushes, plain, type 2*
- Part 10: *Form E, gliding bushes, flanged, type 2*
- Part 11: *Form F, ball cage bushes, flanged, type 2*

# Tools for pressing — Guide bushes —

## Part 5:

### Form D, ball cage bushes, headed, type 1

#### 1 Scope

This part of ISO 9448 specifies the main dimensions and tolerances, in millimetres, of guide bushes of form D, headed ball cage bushes, type 1, intended for use in press tools and to be mounted in the clamp plate with transition fit and fixed to the plate by means of screws.

It gives guidance on the materials, and specifies the hardness and the designation of bushes in accordance with this part of ISO 9448.

#### 2 Dimensions

The dimensions of type 1 headed ball cage bushes (form D) shall conform to the indications in [Figure 1](#) and [Table 1](#).

Details not stated, such as chamfers, radii, lubrication grooves, are left to the manufacturer's discretion.

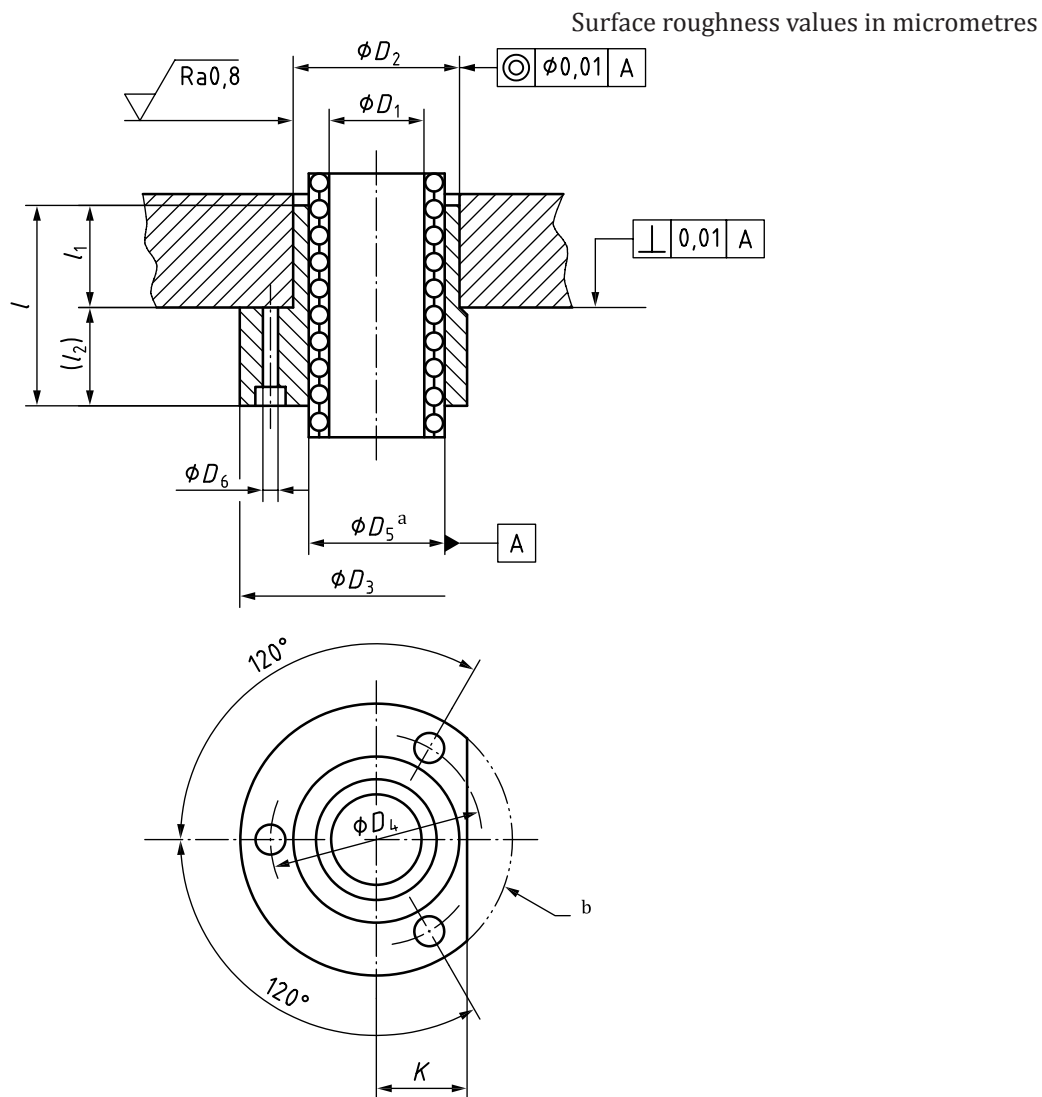

- a The manufacturer shall determine the internal diameter,  $D_5$ , of the bush, using the tolerance M5. This diameter is intended to be lapped or ground to ensure the proper preloading of the balls between the pillar and the bush, as determined by the manufacturer. This lapping or grinding operation shall be carried out to give a surface roughness  $Ra = 0,05 \mu\text{m}$  and this diameter shall act as a reference diameter for the concentricity and perpendicularity tolerances.
- b Left to the manufacturer's discretion.

**Figure 1 — Form D, headed ball cage bushes, type 1**



**Table 1**

$D_1$		16	20	25	32	40	50						
$D_2$ k5 <sup>a</sup>		28	32	40	48	58	70						
$D_3$		45	50	63	72	85	104						
$D_4$		35	40	50	58	70	86						
Clearance hole	$D_6$	4,5	4,5	5,5	5,5	6,6	9						
For screw		M4	M4	M5	M5	M6	M8						
$K$		15	18	23	28	33	38						
nom.	$l_1$ tol.	$l$	$(l_2)$	$l$	$(l_2)$	$l$	$(l_2)$	$l$	$(l_2)$	$l$	$(l_2)$	$l$	$(l_2)$
25	-2,0 -2,5	31	6	40	15								
32		38	6	47	15	57	25						
40	-3 -4			55	15	65	25	65	25	70	30		
50								75	25	80	30	92	42
63												105	42
To prevent incorrect assembly of the upper and lower plates of the die set in relation to each other, the following values of $D_1$ are recommended: 15, 19, 24, 30, 38 and 48.													
<sup>a</sup> Intended to fit into a hole having a tolerance of H7.													

### 3 Material

The material is left to the manufacturer's discretion and the hardness shall be  $(63 \pm 1)$  HRC.

### 4 Designation

A guide bush in accordance with this part of ISO 9448 shall be designated by:

- "Guide bush";
- a reference to this part of ISO 9448, i.e ISO 9448-5;
- its form;
- its guiding diameter,  $D_1$ , in millimetres;
- its length,  $l_1$ , in millimetres.

EXAMPLE A guide bush of form D, headed ball cage bush, type 1 of guiding diameter  $D_1 = 16$  mm and of length  $l_1 = 25$  mm is designated as follows:

**Guide bush ISO 9448-5 D - 16 × 25**

## Bibliography

- [1] ISO 6508-1, *Metallic materials — Rockwell hardness test — Part 1: Test method*







# British Standards Institution (BSI)

BSI is the national body responsible for preparing British Standards and other standards-related publications, information and services.

BSI is incorporated by Royal Charter. British Standards and other standardization products are published by BSI Standards Limited.

## About us

We bring together business, industry, government, consumers, innovators and others to shape their combined experience and expertise into standards-based solutions.

The knowledge embodied in our standards has been carefully assembled in a dependable format and refined through our open consultation process. Organizations of all sizes and across all sectors choose standards to help them achieve their goals.

## Information on standards

We can provide you with the knowledge that your organization needs to succeed. Find out more about British Standards by visiting our website at [bsigroup.com/standards](http://bsigroup.com/standards) or contacting our Customer Services team or Knowledge Centre.

## Buying standards

You can buy and download PDF versions of BSI publications, including British and adopted European and international standards, through our website at [bsigroup.com/shop](http://bsigroup.com/shop), where hard copies can also be purchased.

If you need international and foreign standards from other Standards Development Organizations, hard copies can be ordered from our Customer Services team.

## Subscriptions

Our range of subscription services are designed to make using standards easier for you. For further information on our subscription products go to [bsigroup.com/subscriptions](http://bsigroup.com/subscriptions).

With **British Standards Online (BSOL)** you'll have instant access to over 55,000 British and adopted European and international standards from your desktop. It's available 24/7 and is refreshed daily so you'll always be up to date.

You can keep in touch with standards developments and receive substantial discounts on the purchase price of standards, both in single copy and subscription format, by becoming a **BSI Subscribing Member**.

**PLUS** is an updating service exclusive to BSI Subscribing Members. You will automatically receive the latest hard copy of your standards when they're revised or replaced.

To find out more about becoming a BSI Subscribing Member and the benefits of membership, please visit [bsigroup.com/shop](http://bsigroup.com/shop).

With a **Multi-User Network Licence (MUNL)** you are able to host standards publications on your intranet. Licences can cover as few or as many users as you wish. With updates supplied as soon as they're available, you can be sure your documentation is current. For further information, email [bsmusales@bsigroup.com](mailto:bsmusales@bsigroup.com).

## BSI Group Headquarters

389 Chiswick High Road London W4 4AL UK

## Revisions

Our British Standards and other publications are updated by amendment or revision.

We continually improve the quality of our products and services to benefit your business. If you find an inaccuracy or ambiguity within a British Standard or other BSI publication please inform the Knowledge Centre.

## Copyright

All the data, software and documentation set out in all British Standards and other BSI publications are the property of and copyrighted by BSI, or some person or entity that owns copyright in the information used (such as the international standardization bodies) and has formally licensed such information to BSI for commercial publication and use. Except as permitted under the Copyright, Designs and Patents Act 1988 no extract may be reproduced, stored in a retrieval system or transmitted in any form or by any means – electronic, photocopying, recording or otherwise – without prior written permission from BSI. Details and advice can be obtained from the Copyright & Licensing Department.

## Useful Contacts:

### Customer Services

**Tel:** +44 845 086 9001

**Email (orders):** [orders@bsigroup.com](mailto:orders@bsigroup.com)

**Email (enquiries):** [cservices@bsigroup.com](mailto:cservices@bsigroup.com)

### Subscriptions

**Tel:** +44 845 086 9001

**Email:** [subscriptions@bsigroup.com](mailto:subscriptions@bsigroup.com)

### Knowledge Centre

**Tel:** +44 20 8996 7004

**Email:** [knowledgecentre@bsigroup.com](mailto:knowledgecentre@bsigroup.com)

### Copyright & Licensing

**Tel:** +44 20 8996 7070

**Email:** [copyright@bsigroup.com](mailto:copyright@bsigroup.com)



...making excellence a habit.™