

BS ISO 9284:2013



BSI Standards Publication

Abrasive grains — Test-sieving machines

bsi.

...making excellence a habit.™

National foreword

This British Standard is the UK implementation of ISO 9284:2013. It supersedes BS 7425-4:1993 which is withdrawn.

The UK participation in its preparation was entrusted to Technical Committee MTE/13, Grinding wheels, abrasive tools, paper and cloths, and powders.

A list of organizations represented on this committee can be obtained on request to its secretary.

This publication does not purport to include all the necessary provisions of a contract. Users are responsible for its correct application.

© The British Standards Institution 2013. Published by BSI Standards Limited 2013

ISBN 978 0 580 76012 9

ICS 19.120; 25.100.70

Compliance with a British Standard cannot confer immunity from legal obligations.

This British Standard was published under the authority of the Standards Policy and Strategy Committee on 30 April 2013.

Amendments issued since publication

Date	Text affected
------	---------------

INTERNATIONAL
STANDARD

BS ISO 9284:2013

ISO
9284

Second edition
2013-04-15

**Abrasive grains — Test-sieving
machines**

Grains abrasifs — Machine à tamiser de contrôle



Reference number
ISO 9284:2013(E)

© ISO 2013



COPYRIGHT PROTECTED DOCUMENT

© ISO 2013

All rights reserved. Unless otherwise specified, no part of this publication may be reproduced or utilized otherwise in any form or by any means, electronic or mechanical, including photocopying, or posting on the internet or an intranet, without prior written permission. Permission can be requested from either ISO at the address below or ISO's member body in the country of the requester.

ISO copyright office
Case postale 56 • CH-1211 Geneva 20
Tel. + 41 22 749 01 11
Fax + 41 22 749 09 47
E-mail copyright@iso.org
Web www.iso.org

Published in Switzerland

Contents

	Page
Foreword	iv
1 Scope	1
2 Normative references	1
3 Operational requirements	1
4 Technical description	1
5 Technical requirements	3
5.1 Nest of test sieves and sieve frames	3
5.2 Sieving time	3
6 Installation of test-sieving machines	3
7 Checking of test-sieving machines	3
8 Maintenance of test-sieving machines	3

Foreword

ISO (the International Organization for Standardization) is a worldwide federation of national standards bodies (ISO member bodies). The work of preparing International Standards is normally carried out through ISO technical committees. Each member body interested in a subject for which a technical committee has been established has the right to be represented on that committee. International organizations, governmental and non-governmental, in liaison with ISO, also take part in the work. ISO collaborates closely with the International Electrotechnical Commission (IEC) on all matters of electrotechnical standardization.

International Standards are drafted in accordance with the rules given in the ISO/IEC Directives, Part 2.

The main task of technical committees is to prepare International Standards. Draft International Standards adopted by the technical committees are circulated to the member bodies for voting. Publication as an International Standard requires approval by at least 75 % of the member bodies casting a vote.

Attention is drawn to the possibility that some of the elements of this document may be the subject of patent rights. ISO shall not be held responsible for identifying any or all such patent rights.

ISO 9284 was prepared by Technical Committee ISO/TC 29, *Small tools*, Subcommittee SC 5, *Grinding wheels and abrasives*.

This second edition cancels and replaces the first edition (ISO 9284:1992), of which it constitutes a minor revision. In particular, the normative references have been updated.

Abrasive grains — Test-sieving machines

1 Scope

This International Standard specifies the operational and technical requirements of, and gives guidance on, the installation, checking and maintenance of test-sieving machines.

Test-sieving machines are used for determining the size distribution of bonded and coated abrasive macrograins.

2 Normative references

The following documents, in whole or in part, are normatively referenced in this document and are indispensable for its application. For dated references, only the edition cited applies. For undated references, the latest edition of the referenced document (including any amendments) applies.

ISO 2591-1:1988, *Test sieving — Part 1: Methods using test sieves of woven wire cloth and perforated metal plate*

ISO 6344-1, *Coated abrasives — Grain size analysis — Part 1: Grain size distribution test*

ISO 6344-2, *Coated abrasives — Grain size analysis — Part 2: Determination of grain size distribution of macrogrits P12 to P220*

ISO 8486-1, *Bonded abrasives — Determination and designation of grain size distribution — Part 1: Macrogrits F4 to F220*

3 Operational requirements

Under defined operating conditions, mechanical test sieving can produce results comparable with those obtained by manual sieving.

The results obtained by using test-sieving machines shall be reproducible and shall comply with the requirements specified in ISO 2591-1, ISO 6344-1, ISO 6344-2 and ISO 8486-1.

The reproducibility of the determination of the grain size distribution of abrasive grains by means of sieving is ensured only when the appropriate test-sieving machines, test sieves and operating instructions are used.

4 Technical description

Examples of test-sieving machines are given in [Figure 1](#).

Test-sieving machines usually consist of the following basic components:

- a) support and frame;
- b) electric motor;
- c) gear drive for the conversion of the rotary motion of the motor into the specified eccentric rotary motion of the nest of sieves and into the tapping action;
- d) switch, which is actuated by means of a time switch;
- e) tapper for the execution of the vertical strokes (which are specified for a given unit of time on the cover of the nest of sieves);

- f) retainer for the bottom pan and nest of sieves, which allows them to move in the specified manner;
- g) cover for the sieves, fitted with a funnel-shaped insert with a plug (usually made of cork), on which the tapper strikes.

In addition, the following are necessary for the operation of test-sieving machines:

- base plate;
- a nest of five test sieves;
- bottom pan.

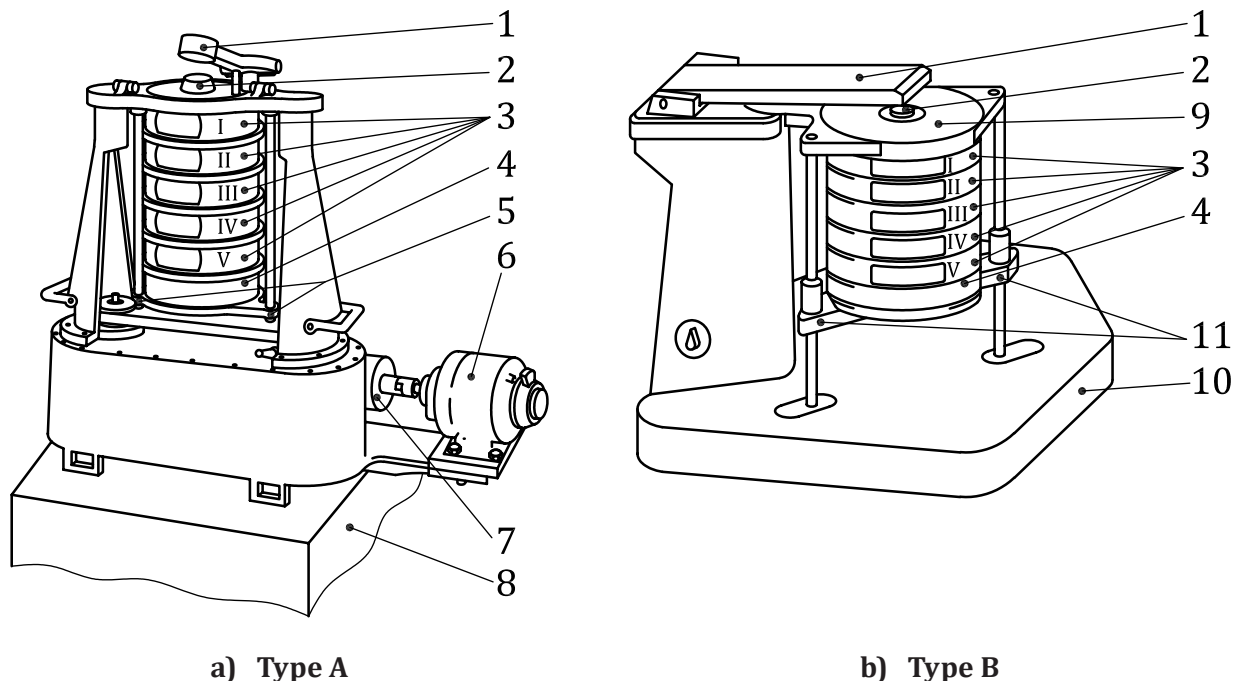

Key

- | | | | |
|---|--------------------------------|----|---------------|
| 1 | tapper | 1 | tapper |
| 2 | cork plug | 2 | cork plug |
| 3 | test sieves | 3 | test sieves |
| 4 | bottom pan | 4 | bottom pan |
| 5 | fixing screws for bottom plate | 9 | cover |
| 6 | electric motor block | 10 | bottom plate |
| 7 | gear drive | 11 | fixing screws |
| 8 | base plate | | |

NOTE This figure illustrates typical commercially available test-sieving machines, type A and type B.

Figure 1 — Examples of test-sieving machines

5 Technical requirements

5.1 Nest of test sieves and sieve frames

The nest of test sieves shall be mounted in the sieving machine in such a way that the prescribed movements are possible without any obstruction. Attention shall be paid to the manufacturer's recommendations.

The sieve frames of the test sieves shall have the following dimensions:

- a) diameter, 200 mm;
- b) height, 50 mm.

The nest of test sieves to be used for a particular type of macrograin shall be as specified in the applicable standard.

5.2 Sieving time

The test-sieving machines shall be provided with a time switch to guarantee that sieving is carried out for the prescribed time period.

6 Installation of test-sieving machines

The test-sieving machine shall be fixed on to a suitable baseplate of sufficient mass in such a way that external vibrations cannot reach the machine.

The test-sieving machine shall be installed so that it is horizontal.

As an example, the type A test-sieving machine (see [Figure 1](#)) shall be fixed on a concrete baseplate having a width of at least 625 mm, a depth of 500 mm and a height of 550 mm. For the design of the concrete baseplate, as well as for the arrangement of the assembly bolts, see [Figure 2](#).

The concrete base-plate should be placed on a vibration-absorbing board, made, for example, of hard felt, which serves also to compensate for unevenness of the ground.

The ground shall be free from vibrations, i.e. it should be natural soil. Where it is not possible to meet this requirement, the test-sieving machine should be installed in such a way that the forces and moments, which occur during the operation of the machine, are transmitted via the load-bearing structure to the foundations.

If an acoustic cabinet is used, it shall not be attached to either the sieving machine or the concrete block.

7 Checking of test-sieving machines

The efficiency of test-sieving machines shall be checked at appropriate intervals; in particular, the performance of the tapper and the precision of the time switch shall be checked.

8 Maintenance of test-sieving machines

In order to maintain the efficiency and operational reliability of test-sieving machines, it is recommended that the manufacturer's instructions concerning maintenance are followed.

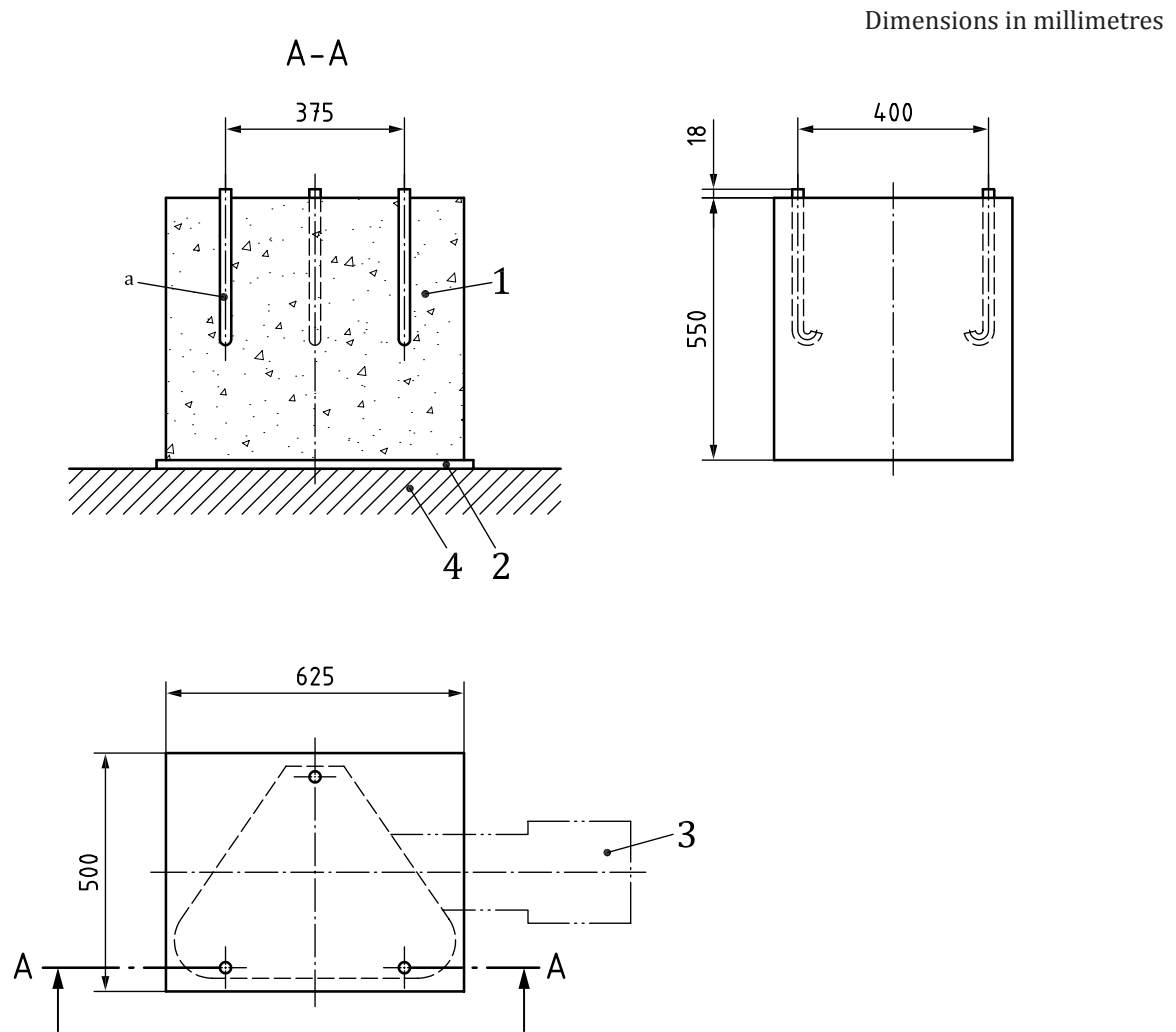

Key

- 1 concrete
- 2 vibration-absorbing board (e.g. hard felt)
- 3 outline of test sieving machine
- 4 ground
- a Three assembly bolts, thread M10.

Figure 2 — Baseplate and mating dimensions for the assembly of test-sieving machines, type A

British Standards Institution (BSI)

BSI is the national body responsible for preparing British Standards and other standards-related publications, information and services.

BSI is incorporated by Royal Charter. British Standards and other standardization products are published by BSI Standards Limited.

About us

We bring together business, industry, government, consumers, innovators and others to shape their combined experience and expertise into standards-based solutions.

The knowledge embodied in our standards has been carefully assembled in a dependable format and refined through our open consultation process. Organizations of all sizes and across all sectors choose standards to help them achieve their goals.

Information on standards

We can provide you with the knowledge that your organization needs to succeed. Find out more about British Standards by visiting our website at bsigroup.com/standards or contacting our Customer Services team or Knowledge Centre.

Buying standards

You can buy and download PDF versions of BSI publications, including British and adopted European and international standards, through our website at bsigroup.com/shop, where hard copies can also be purchased.

If you need international and foreign standards from other Standards Development Organizations, hard copies can be ordered from our Customer Services team.

Subscriptions

Our range of subscription services are designed to make using standards easier for you. For further information on our subscription products go to bsigroup.com/subscriptions.

With **British Standards Online (BSOL)** you'll have instant access to over 55,000 British and adopted European and international standards from your desktop. It's available 24/7 and is refreshed daily so you'll always be up to date.

You can keep in touch with standards developments and receive substantial discounts on the purchase price of standards, both in single copy and subscription format, by becoming a **BSI Subscribing Member**.

PLUS is an updating service exclusive to BSI Subscribing Members. You will automatically receive the latest hard copy of your standards when they're revised or replaced.

To find out more about becoming a BSI Subscribing Member and the benefits of membership, please visit bsigroup.com/shop.

With a **Multi-User Network Licence (MUNL)** you are able to host standards publications on your intranet. Licences can cover as few or as many users as you wish. With updates supplied as soon as they're available, you can be sure your documentation is current. For further information, email bsmusales@bsigroup.com.

BSI Group Headquarters

389 Chiswick High Road London W4 4AL UK

Revisions

Our British Standards and other publications are updated by amendment or revision.

We continually improve the quality of our products and services to benefit your business. If you find an inaccuracy or ambiguity within a British Standard or other BSI publication please inform the Knowledge Centre.

Copyright

All the data, software and documentation set out in all British Standards and other BSI publications are the property of and copyrighted by BSI, or some person or entity that owns copyright in the information used (such as the international standardization bodies) and has formally licensed such information to BSI for commercial publication and use. Except as permitted under the Copyright, Designs and Patents Act 1988 no extract may be reproduced, stored in a retrieval system or transmitted in any form or by any means – electronic, photocopying, recording or otherwise – without prior written permission from BSI. Details and advice can be obtained from the Copyright & Licensing Department.

Useful Contacts:

Customer Services

Tel: +44 845 086 9001

Email (orders): orders@bsigroup.com

Email (enquiries): cservices@bsigroup.com

Subscriptions

Tel: +44 845 086 9001

Email: subscriptions@bsigroup.com

Knowledge Centre

Tel: +44 20 8996 7004

Email: knowledgecentre@bsigroup.com

Copyright & Licensing

Tel: +44 20 8996 7070

Email: copyright@bsigroup.com



...making excellence a habit.™