

Measurement of total discharge in open channels — Electromagnetic method using a full-channel-width coil

ICS 17.120.20

National foreword

This British Standard reproduces verbatim ISO 9213:2004 and implements it as the UK national standard. It supersedes BS 3680-3H:1993 which is withdrawn.

The UK participation in its preparation was entrusted by Technical Committee CPI/113, Hydrometry, to Subcommittee CPI/113/1, Velocity-area methods, which has the responsibility to:

- aid enquirers to understand the text;
- present to the responsible international/European committee any enquiries on the interpretation, or proposals for change, and keep the UK interests informed;
- monitor related international and European developments and promulgate them in the UK.

A list of organizations represented on this subcommittee can be obtained on request to its secretary.

Cross-references

The British Standards which implement international publications referred to in this document may be found in the *BSI Catalogue* under the section entitled “International Standards Correspondence Index”, or by using the “Search” facility of the *BSI Electronic Catalogue* or of British Standards Online.

This publication does not purport to include all the necessary provisions of a contract. Users are responsible for its correct application.

Compliance with a British Standard does not of itself confer immunity from legal obligations.

Summary of pages

This document comprises a front cover, an inside front cover, the ISO title page, pages ii to iv, pages 1 to 19 and a back cover.

The BSI copyright notice displayed in this document indicates when the document was last issued.

Amendments issued since publication

Amd. No.	Date	Comments

This British Standard was published under the authority of the Standards Policy and Strategy Committee on 23 March 2004

© BSI 23 March 2004

ISBN 0 580 45658 7

INTERNATIONAL
STANDARD

ISO
9213

Second edition
2004-04-01

**Measurement of total discharge in open
channels — Electromagnetic method
using a full-channel-width coil**

*Mesurage du débit total dans les canaux découverts — Méthode
électromagnétique à l'aide d'une bobine d'induction couvrant toute la
largeur du chenal*



Reference number
ISO 9213:2004(E)

Contents

	Page
1 Scope	1
2 Normative references	1
3 Terms and definitions	1
4 Principles of operation and practice	1
5 Applications	5
6 Selection of site	6
7 Design and construction	6
8 Uncertainties in flow measurement	12
9 Gauge calibration and verification	13
Annex A (informative) Site survey for electrical interference	14
Annex B (informative) Design aspects of the electromagnetic coil	15
Annex C (informative) Numerical example of the calculation of uncertainty	16
Annex D (normative) Gauge calibration procedure	17
Bibliography	19

Foreword

ISO (the International Organization for Standardization) is a worldwide federation of national standards bodies (ISO member bodies). The work of preparing International Standards is normally carried out through ISO technical committees. Each member body interested in a subject for which a technical committee has been established has the right to be represented on that committee. International organizations, governmental and non-governmental, in liaison with ISO, also take part in the work. ISO collaborates closely with the International Electrotechnical Commission (IEC) on all matters of electrotechnical standardization.

International Standards are drafted in accordance with the rules given in the ISO/IEC Directives, Part 2.

The main task of technical committees is to prepare International Standards. Draft International Standards adopted by the technical committees are circulated to the member bodies for voting. Publication as an International Standard requires approval by at least 75 % of the member bodies casting a vote.

Attention is drawn to the possibility that some of the elements of this document may be the subject of patent rights. ISO shall not be held responsible for identifying any or all such patent rights.

ISO 9213 was prepared by Technical Committee ISO/TC 113, *Hydrometry*, Subcommittee SC 1, *Velocity area methods*.

This second edition cancels and replaces the first edition (ISO 9213:1992), which has been technically revised.

Measurement of total discharge in open channels — Electromagnetic method using a full-channel-width coil

1 Scope

This International Standard specifies procedures for the establishment and operation of a gauging station, equipped with an electromagnetic flow meter, in an open channel or a closed conduit with a free water surface.

This International Standard is applicable to configurations where an artificial magnetic field is generated through which the entire body of water flows. The induced voltage is sensed in such a way that all elements of the moving water contribute. The equipment described normally requires an electrical mains power supply.

This International Standard is not applicable to devices sampling only part of the flowing body of water (e.g. velocity meters) or to flow meters which operate by using the Earth's magnetic field.

2 Normative references

The following referenced documents are indispensable for the application of this document. For dated references, only the edition cited applies. For undated references, the latest edition of the referenced document (including any amendments) applies.

ISO 748, *Measurement of liquid flow in open channels — Velocity-area methods*

ISO 772, *Hydrometric determinations — Vocabulary and symbols*

ISO 1100-2, *Measurement of liquid flow in open channels — Part 2: Determination of the stage-discharge relation*

ISO 5168:—¹⁾, *Measurement of fluid flow — Evaluation of uncertainties*

ISO/TR 7066-1, *Assessment of uncertainty in calibration and use of flow measurement devices — Part 1: Linear calibration relationships*

3 Terms and definitions

For the purposes of this document, the terms and definitions given in ISO 772 apply.

4 Principles of operation and practice

4.1 This is a velocity-area method of discharge determination. The electromagnetic gauge operates on Faraday's principle of electromagnetic induction. If a length of conductor moves through a magnetic field, a voltage is generated between the ends of the conductor. In the electromagnetic gauge, a vertical magnetic field is generated by means of an insulated coil which is located either above or beneath the channel. The conductor is formed by the water which moves through the magnetic field; the ends of the conductor are represented by the channel walls or riverbanks. The voltage generated is sensed by electrodes on the channel extremities and these are connected to the input of a sensitive voltage-measuring device. The faster the velocity of the water, the greater is the voltage which is generated.

1) To be published. (Revision of ISO/TR 5168:1998)

4.2 The principle is widely applied to flow meters in circular pipes running full and in this case approximate formulae may be generated theoretically and refinement made by calibration through factory produced models.

The open channel flow meter however does not lend itself to such treatment and hence *in situ* calibration is always necessary.

4.3 Bevir's formula for the potential generated between electrodes placed in a body of conducting fluid moving in a magnetic field is given by Equation (1) and illustrated in Figure 1.

$$E = \int B \times j \times v \times d\tau \quad (1)$$

where

- E is the potential between the electrodes;
- B is the vector magnetic induction;
- j is the vector virtual current between the electrodes;
- v is the vector velocity function;
- $d\tau$ is an element of volume.

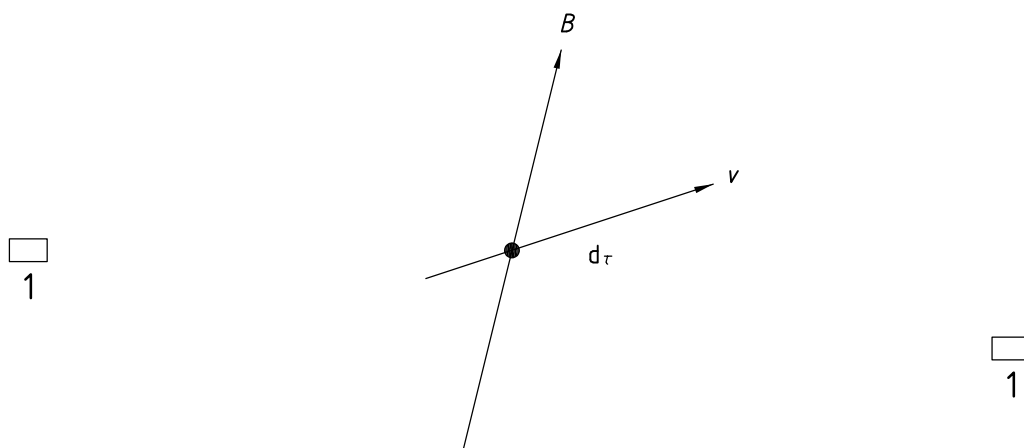

Key

1 electrode

Figure 1 — Illustration of Bevir's formula

This involves integration between the electrodes over the entire space occupied by the fluid. In practice, the general case is not solvable since the spatial functions are unknown or difficult to determine. In the simple case of a rectangular horizontal channel of width w , expressed in metres, with water flowing with a mean velocity v , expressed in metres per second, in a uniform vertical magnetic field H , expressed in amperes per metre, the induced potential E , expressed in microvolts, is measured at electrodes at the sides and is calculated using Equation (2).

$$E \propto v \times w \times H \quad (2)$$

where

$$H = B/\mu$$

μ is the magnetic permeability of the fluid.

In practice, numerically,

$$E \cong v \times w \times H$$

4.4 In this simple case, if the water depth is d metres, the flow q , expressed in cubic metres per second, is given by the following equation:

$$q = v \times w \times d = E \times d/H$$

If the field H is produced by an electromagnet in the form of an arrangement of coil(s), then for a given situation, H is proportional to the electrical current I , expressed in amperes, in the coil. Therefore

$$q = K \times E \times d/I$$

where K is a constant.

In practice, this is an oversimplification and a more generally applicable form of the flow formula, taking account of non-uniformities, is

$$q = K \times E \times f(d)/I$$

where $f(d)$ is a polynomial function of d .

Usually, a close approximation is obtained where the polynomial is a quadratic, i.e.

$$q = (E/I) \times (K_1 + K_2d + K_3d^2) \quad (3)$$

4.5 However, there is a sensitivity to non-uniform velocity distribution in the presence of non-uniformities in other parameters. Though the mathematical treatment is complex, for the purposes of this International Standard, it may be stated that if the vertical magnetic field is not uniform then changes to the velocity profile for given flow and depth values will produce an apparent change in the measured induced voltage. This will have the effect of producing an uncertainty in the flow value determined by the flow meter.

The designer of the flow meter should strive to produce a vertical magnetic field as uniform as possible to minimize this uncertainty. A single coil above or below a channel may be sufficient if it is wide compared with the depth of water. Alternatively, better uniformity may be obtained by "saddle-shaped" coils or a pair of coils deployed above and below the channel. The design of coil systems is not covered in this International Standard although some design considerations are given in Annex B.

4.6 With most channels, the material comprising the bed and sides will have an electrical conductivity which cannot be ignored compared with that of the water flowing in the channel (even if the material is concrete). The apparent induced potential is thus reduced in the same way that voltage at the terminals of a battery is less if measured whilst a load is connected. Though attempts have been made to determine the effect and allow for it, these have generally proved unsuccessful. The recommendation is always to line the channel with an electrically insulating material which substantially removes the conduction path through the channel material (see 7.2.3).

Depending on the material used for lining the channel, some form of protection is often required to prevent physical damage by debris being transported along the channel by the flowing water. This protective layer is usually concrete and this itself will have a conductivity when wet which may be different from that of the water. The effect of this is much the same as a layer of silt which may settle on the bed and is described in 4.7.

4.7 A layer of silt settling on the bed (or the protective layer described in 4.6) may have an effect on the induced voltage and hence the flow calculated by the flow meter.

Assuming the magnetic field is fairly uniform then the effect described in 4.5 is negligible.

If the wet silt has a similar conductivity to that of the water, it will be seen as a non-moving (or slowly moving) layer of water. This is similar to a step change in velocity profile and the flow meter should be programmed with an effective bed level beneath the silt (at the level of the insulating liner). If, however, the layer has a very low conductivity (packed clay for example), it will behave like an extension of the liner. In this case, the flow meter should be programmed with an effective bed position at the top of the silt.

In practice the effective bed level should be taken as the level of the insulating liner. However, sometimes an offset (D_0) to the depth (d) measured from the surface to the liner should be applied. D_0 will depend on the thickness and conductive properties of the silt and will have a value between zero and the thickness of the silt. D_0 is obtained by calibration. It is possible, due to thickness or conductivity variations, that the offset may not be constant and this is a source of uncertainty (see Clause 8).

4.8 The value of induced voltage in a practical application is generally in the range of a few tens to hundreds of microvolts.

In comparison, the electrodes will be subject to various other effects which produce voltages unrelated to the flow-induced signal. These interfering voltages (or noise) will have different magnitudes and frequencies and may be far greater than the induced voltage.

Table 1 gives some indication of the magnitude and frequency of sources of interference that are commonly encountered. Differential magnitude is that measured between the electrodes; common mode is between either electrode and ground.

Table 1 — Sources, frequency or rate of change and interference magnitude

Source	Frequency or rate of change	Interference magnitude (differential)	Interference magnitude (common mode)
Electrical power distribution	50 Hz or 60 Hz	5 mV	1,5 V
High (radio) frequency	Much greater than 1 kHz	5 mV	50 mV
Polarization (electrochemical)	0,01 V/min	1 mV	1 V

It is necessary to create a recognizable pattern for the induced voltage to enable it to be detected in the presence of this larger interference. In practice, this is usually done by alternating the direction of the coil current which causes the induced signal to alternate in synchronism. The signal detection circuit is designed to detect this signal and reject the interference. The choice of the alternating frequency is limited on the one hand by considerations of inductive power loss in the coil and on the other by the need to avoid the frequency of interference, particularly 50 Hz or 60 Hz. This is often a problem in the vicinity of power distribution systems using protective multiple earthing (PME). High frequency (HF) interference is not a problem because it is normally significantly higher than the alternating frequency of the coil. A simple input filter removes it.

Polarization is due to electrochemical action between the water and the electrodes. Though large voltages may occur, they are easily removed electronically unless they are fluctuating at a similar frequency to the alternating coil current. This may be the case in foul sewers when wave motion against the electrodes can occur.

In addition, lightning can produce voltages of thousands of volts, which should be withstood to prevent damage to the flow meter input circuitry.

4.9 Since the coil current is alternating, the possibility exists of electrical “breakthrough” or “coupling” to the electrodes or their connecting cables. Since this coupling would be at the same frequency as the coil-switching signal, it would combine with the flow signal in the synchronous detection circuit to produce an offset voltage. The mechanism for this coupling may be capacitive, inductive or conductive. Care should be taken in the layout of the coil and electrode elements of the flow gauge to ensure symmetry to minimize the capacitive and inductive effects. The quality of insulation of cables and joints should be good to avoid conductive coupling between the elements.

Perfect symmetry is difficult to achieve in practice and a small residual voltage (E_0) often occurs adding to or subtracting from the induced flow signal E .

The value of E_0 is usually constant and may be determined by calibration, see Clause 9. However, the purpose of the calibration procedure is to determine the number of coefficients and much complication may be avoided if the value of E_0 can be determined directly. One way of doing this is to perform a zero check with static water in the gauging section. This may be difficult to achieve in a river but can often be done in an artificial channel.

If this is not possible, an indication of whether a significant value of E_0 exists may be obtained by shorting out the electrodes with a wire placed directly between them. This effectively reduces the induced flow signal E to zero. The residual signal may be less than E_0 since the electrode shorting may also partially reduce the coupled signal.

4.10 From Equation (3), the flow formula therefore becomes

$$q = [(E + E_0)/I] \times [K_1 + K_2(d - D_0) + K_3(d - D_0)^2] \quad (4)$$

5 Applications

5.1 The electromagnetic gauge is particularly suited to the measurement of flow in channels where no well-defined stage-discharge relationship exists, for example where weed growth in a natural river channel causes variable backwater effects, and in artificial channels of effluent discharge where little head loss occurs. Other applications could be in measuring the flow of potable water in treatment works or the flow of cooling water in power stations.

5.2 Different versions of the electromagnetic gauge are suitable for measuring flow in rivers, partly filled pipes or culverts carrying storm water, raw effluent or foul sewage.

5.3 The advantages of the method include the following:

- a) tolerates weed growth;
- b) tolerates entrained air;
- c) tolerates temperature stratification;
- d) tolerates suspended sediment or floating debris in the water;
- e) tolerates deposited sediment or other accretion on the channel bed;
- f) tolerates variable backwater;
- g) tolerates upstream inflows; however, if the inflow conductivity is significantly different from that of the main channel, there shall be sufficient distance for adequate mixing;
- h) can be designed to detect a minimum velocity of about 0,001 m/s;
- i) tolerates irregular velocity profiles, depending on the shape of the magnetic field, including skew flow and severe eddy currents in the measurement area;
- j) can be suitable for gauging shallow water provided D_0 can be accurately defined (see 4.7);
- k) inherently integrates the velocity profile over the entire channel cross-section;
- l) affords a wide range of discharge measurements to a typical dynamic range of 1:1 000;
- m) does not constrict the flow;
- n) can measure reverse flow;
- o) does not increase upstream water levels;
- p) does not inhibit the passage of migratory fish.

5.4 There are however some disadvantages associated with the method, such as

- a) the complexity of the construction, which may involve temporary diversion of flow and lining of the channel;
- b) the need for calibration, which may prove substantially complex and may take a significant period of time to complete satisfactorily over the range of measurement required;
- c) the need to derive a solution to the formula involved in computing the flow which is mathematically complex;
- d) the effects of electrical interference from other sources (see 4.8);
- e) the requirement for a reliable electricity supply;
- f) the speed of response which is not instantaneous, which precludes its use where fast control operations are required;
- g) the effect on accuracy of spatial differences in water conductivity, e.g. caused by saline intrusion.

6 Selection of site

6.1 A site survey should be carried out if necessary as outlined in Annex A to measure any external electrical interference (e.g. power cables, radio stations or electric railways). Areas of high electrical interference should be avoided.

In some cases, the current from the electrical power supply flowing to ground may cause excessive voltages to be detected by the electrodes.

6.2 Owing to the high power consumption of the coil, equipment intended to measure flow continuously cannot reasonably be operated continuously from batteries.

6.3 The site shall afford adequate on-bank working space for handling the membrane and cables during construction (or the preformed coil and rigid liner in the case of a smaller channel) and good access for operation and maintenance.

6.4 The site characteristics shall be such that the calibration of the station can be determined by an alternative method, e.g. current-meter gauging.

6.5 Sites shall be selected where there is no spatial variation in water conductivity. The accuracy of the method will be reduced if the spatial conductivity is not uniform across the section. Gradual variations with time are unimportant provided that the spatial uniformity of the conductivity is maintained. This requirement makes an electromagnetic gauge unsuitable for channels in which fresh water flows over saline water, which often occurs in estuaries. Provided that these requirements are met, the quality of the water will not affect the operation of the gauge. Similarly the conductivity of the water will not affect the operation of a gauge in an insulated channel provided that it exceeds 50 $\mu\text{S/m}$.

7 Design and construction

7.1 General

The electromagnetic gauging station should consist of the following elements (see Figures 2 and 3):

- a) a field coil installed beneath or above the channel, or both;
- b) a pair of electrodes, one on each side of the channel;
- c) an insulating membrane; it may be necessary; this may be necessary to protect the liner with a covering material such as concrete or stone blockwork;
- d) an instrumentation unit, including a coil power supply unit;
- e) equipment housing;
- f) a water-level measuring device (see 7.2.5).

These elements can be separate but some systems combine a number of these elements into one unit.

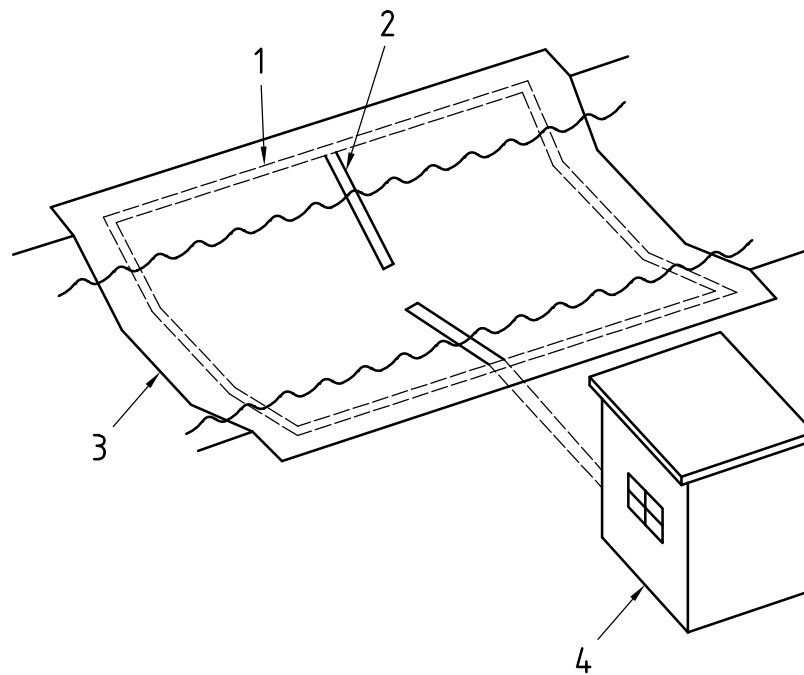
**Key**

- 1 field coil
- 2 electrodes
- 3 insulating membrane
- 4 hut containing instrumentation unit

Figure 2 — Buried coil configuration

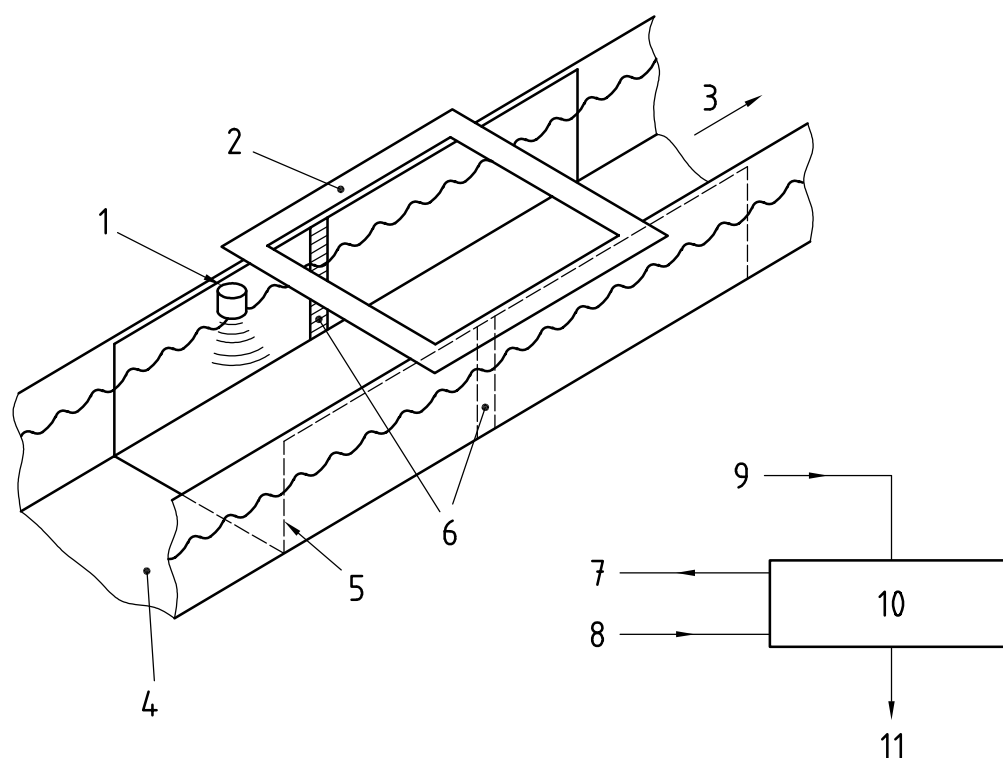

Key

- | | |
|----|----------------------|
| 1 | level sensor |
| 2 | field coil |
| 3 | flow |
| 4 | channel |
| 5 | insulating membrane |
| 6 | electrodes |
| 7 | coil current |
| 8 | depth data |
| 9 | electrode potential |
| 10 | instrumentation unit |
| 11 | displays |

Figure 3 — Bridged coil configuration

7.2 System equipment

7.2.1 Coil

7.2.1.1 The sensitivity of the equipment to the flow is improved by increasing the strength of the field. This is proportional to the number of turns in the coil and also to the current flowing through the coil. The energy required to produce the magnetic field in a coil of a certain size, number of turns and current is inversely proportional to the cross-sectional area of the conductors which make up the coil. It is also proportional to the electrical resistivity of the material used for the conductors. A compromise should be made, therefore, between the capital cost of the cable, electricity running costs and strength of electrical interference, and the resolution required in the determination of flow.

In practice, a coil with a square configuration slightly larger than the channel width and of some 200 ampere turns to 1 000 ampere turns, should cover most practical situations.

7.2.1.2 Any electrical leakage between the coil and the water in the channel will create voltages across the width of the channel. These voltages cannot be separated from those generated by the movement of water through the magnetic field and will produce an apparent offset in the readings of the equipment.

If the coil is located beneath the channel, the use of a polyethylene-insulated cable with a polyethylene outer sleeve is recommended. In all cases, the insulation between the coil and earth (or the water surrounding the coil) shall exceed $5 \times 10^8 \Omega$.

7.2.1.3 The coil shall be installed in ducting (normally of about 250 mm diameter) to afford access for maintenance of the cable. Construction constraints normally require the coil to be square in plan.

For a bridged coil, a lesser grade of insulation such as polyvinyl chloride (PVC) is acceptable. The coil shall span the full width of the river above the maximum stage at which measurements are required. If the coil is likely to be submerged, it shall be able to withstand impact by floating debris. If meaningful measurements are required in this condition, the insulation shall exceed $5 \times 10^8 \Omega$ when submerged.

7.2.1.4 For convenience, the coil may be wound with a multi-core cable and it should not be armoured.

7.2.1.5 In cases where installation is in potentially explosive atmospheres, the design should be approved by an appropriate body. The design should be such that it limits the energy that could be transferred to the explosive atmosphere if a fault were to occur.

7.2.1.6 The frequency at which the magnetic field is reversed shall be low enough to permit a stable field to be established, but not so low as to permit polarization effects to become significant. Typical frequencies would be in the range 0,5 cycle/s or 1 cycle/s (0,5 Hz to 1 Hz). The coil current should be either measured or, alternatively, stabilized at a fixed value.

7.2.1.7 A typical coil design is described in Annex B.

7.2.2 Electrodes

7.2.2.1 It is recommended that the electrodes be made from stainless steel strip or tube. Typically, the width of flat electrodes may be in the range 50 mm to 100 mm. Tubular electrodes should be of the order of 10 mm to 20 mm diameter.

7.2.2.2 In channels containing foul water which is liable to putrify, the electrode mounting shall not permit such water to become trapped in pockets or crevices near the electrode, and no mechanical filter shall be used.

7.2.2.3 In the event of a lightning strike in the vicinity of the gauge, high voltages may be generated. The gauge may require protection to avoid being damaged.

7.2.2.4 The inductive or capacitive coupling between the signal cable and the coil shall be a minimum in order to reduce the effects described in 4.9. This can be achieved by the feed from the electrode on the far bank passing in a straight line through the coil centre to bisect the plan area of the coil. An alternative arrangement is to take two signal cables from the far bank electrode: one cable passes through the same ducting as the upstream coil cable and the second electrode cable passes through the downstream coil ducting. The signals from these two cables are added together using a resistance network. Ducting for the electrode cables either shall cross the channel beneath the insulating membrane (if used) or shall be bridged across the channel.

7.2.2.5 In open channels, the electrodes may be supported in guides mounted on the walls or banks on either side of the channel in order that they can easily be removed for maintenance. Such mountings shall extend throughout the full depth of flow. The guides may consist of slotted plastic rods for flat electrodes or perforated plastic tubing for tubular electrodes. Alternatively the electrodes may be moulded into glass-reinforced plastic units, with only one face of the metal electrode exposed. The guides shall be secured to the channel walls or banks, but the membrane shall not be punctured (except as specified in 7.2.3.4) (see Figure 2).

In closed conduits the electrodes may be installed as part of the preformed pipe section (see 7.2.3.7 and Figure 4).

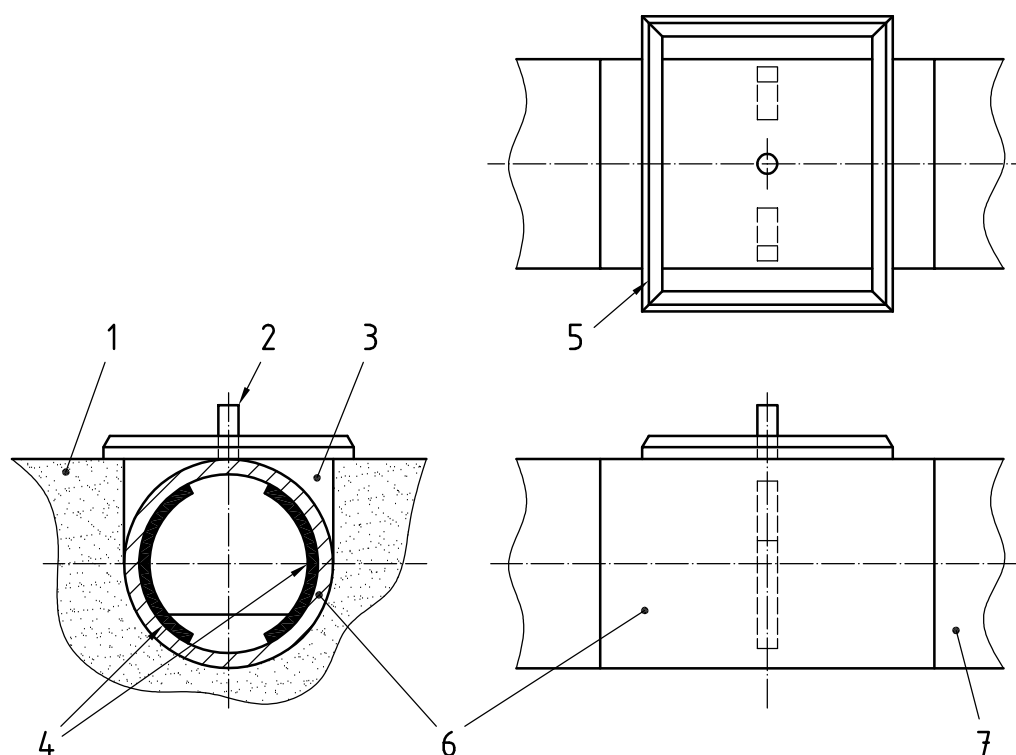

Key

- 1 concrete benching
- 2 level sensor
- 3 U-section channel
- 4 electrodes
- 5 coil supported on benching
- 6 glass-reinforced plastic pipe section
- 7 concrete pipe

Figure 4 — Coil configuration for closed conduits

7.2.3 Insulating membrane

7.2.3.1 An insulating membrane shall be used which is strong enough to withstand the stresses involved. A high-density polyethylene sheet 2 mm or 3 mm thick, or equivalent material, is recommended. The resistivity of the material shall be greater than $10^{12} \Omega \cdot \text{m}$. Alternatively glass-reinforced plastic (GRP) laid up on the walls or fixed in sheets or in preformed shapes could be used.

7.2.3.2 The membrane shall be mechanically anchored and sealed at the leading and side edges to protect against local scour and seepage. The lining shall be laid and secured in such a way as to prevent subsequent movement. The bed at the trailing edge shall be protected against damage by local scour.

7.2.3.3 In practice, the membrane may be covered by a variety of materials to protect it against damage. Acceptable protection on the riverbed is a 100 mm thick layer of concrete (this shall not be reinforced). The banks of the river may be protected by rock-filled non-metallic gabions or, in some instances, a layer of concrete. In a rectangular channel, the membrane may be set behind a vertical wall of concrete or similar material, such as concrete blocks or clay bricks. No metal reinforcement or wire rope shall be used within the

insulated reach. The thickness of the protective layer should be kept to a minimum to avoid the uncertainty of determining the effective bed level. This is particularly important where shallow water is to be encountered.

7.2.3.4 The membrane shall not be punctured, except along the edges for anchoring purposes. For this reason the take-off point to a stilling well, where included, shall be beyond the extremities of the coil.

7.2.3.5 In a concrete channel the upstream leading edge and sides of the membrane should be battened to the concrete or fixed by similar means. In a river, the edges of the membrane may be anchored by concrete bagging to trap the membrane in a trench.

7.2.3.6 It is recommended that the length of the lining be no less than 1,5 times the channel width at the maximum stage at which measurements are to be made. The lining shall be centred with respect to the coil centre.

7.2.3.7 In closed conduits a special preformed section may be inserted in the conduit, as shown in Figure 4. The resistivity of the material shall be greater than $10^{12} \Omega \cdot \text{m}$.

7.2.4 Instrumentation unit

7.2.4.1 The instrumentation shall consist of:

- a) a means of driving the coil (and typically embodies a means of reversing the direction of the coil current), of maintaining a constant coil current or alternatively measuring the coil current for inclusion in the formulae for flow computation;
- b) a means of determining the induced voltage which will typically consist of amplification and electrical filtering to remove unwanted electrical noise; the filtering algorithm will be linked to the switching frequency of the coil;
- c) a means of measuring water depth;
- d) a processing unit capable of combining these in a flow formula;
- e) a number of outputs which may include a visual display, and one or more electronic interfaces to recording, transmission or display devices.

7.2.4.2 To obtain meaningful determinations of flow, measurements shall be averaged over a period of several minutes. A means of altering this averaging period as an aid to checking shall be provided.

7.2.5 Water level measurement

The water level datum as perceived by the equipment will normally be at the mean level of the insulation at the bottom of the channel. If the insulation is covered with a layer of non-conducting material, then the datum is the mean level of the top of this covering. In practice, the effective datum might be at some level between these, to be determined by calibration (see 4.7.)

7.3 Measurement of coil current and electrode voltage

The uncertainty in the magnitude of coil current shall not exceed 1 %, whether measured or controlled.

The uncertainty in the measurement of the induced voltage shall not exceed $\pm 0,5 \mu\text{V}$ or 1 % of the actual value, whichever is greater.

7.4 Signal processing

7.4.1 The equipment shall measure the difference in electrical potential between the electrodes, which is generated by the flow of water, and shall reject the electrical interference. To achieve this, the electronic equipment would normally be expected to:

- a) control accurately the switching of the coil;
- b) measure the coil current or control it to a predetermined value;
- c) protect the electrode potential measuring circuits against the electrical surges induced in the electrodes and connecting cables when the coil current is reversed or by external sources, e.g. lightning;
- d) take account of the polarization potential between the electrodes and provide an automatically adjusting bias to the potential measuring circuits so that they can operate within their linear region;
- e) measure the potential between the electrodes (ignoring common-mode potentials between electrodes and ground) and obtain an average over each coil cycle;
- f) calculate the component of the average potential between the electrodes which is in phase with the magnetic field (this component will be a measure of the signal generated by the flow of water; the calculation should take into account any changes in bias introduced to enable the circuits to operate in their linear range);
- g) from the average potential which is generated by the flow of water, calculate flow in accordance with Equation (4) (see 4.10).

7.4.2 The electrical interference is regarded as random and so will in the longer-term average to zero. In order to obtain consistent measurements of flow, the data shall be averaged over periods generally between 2 min and 15 min, depending on the degree and frequency of the interference. The longer the averaging periods, the slower the speed of response of the gauge to changes in flow. This may not be acceptable in all applications.

7.4.3 When making comparison for calibration purposes, the averaging period should be compatible with the time taken to carry out the comparative measurement.

7.5 Power supply failure

In the event of power failure the equipment shall automatically return to correct operation upon restoration of the power source.

8 Uncertainties in flow measurement

8.1 Calibration graph

Analysis of the uncertainties in the calibration relation shall be carried out as specified in ISO/TR 7066-1 and ISO 1100-2.

Generally for an insulated channel, the random uncertainty at the 95 % confidence level in the value predicted from the calibration relation may be on the order of $\pm 2\%$ to $\pm 5\%$.

8.2 Single determination of discharge

8.2.1 The uncertainty in a single determination of discharge may be calculated in accordance with ISO 5168 or ISO 748 by combining the component uncertainties in the equations using the root-mean-square method. Values for these component uncertainties should be estimated independently for each site. A numerical example is given in Annex C.

8.2.2 The component uncertainties are the following:

- a) the variability of the water velocity profile (this is important on those sites where the coil does not produce a near-constant magnetic field over the entire channel cross-section);
- b) the measurement or control of the coil current (the magnetic field strength H is proportional to the current and hence the computed flow is inversely proportional to the current);
- c) the measurement of depth, relative to the effective channel bed level (see 4.7);
- d) the measurement of the three components of the electrode potential:
 - 1) the fixed offset, observable at zero flow (on most rivers this value may be inferred from a relation between electrode potential and flow, extrapolated to zero flow);
 - 2) the uncertainty of the voltage measurement device in the electromagnetic gauge;
 - 3) the variability with time, caused by electrical interference, which can be assessed by comparison of the variabilities of computed flow for different lengths of integration time.

9 Gauge calibration and verification

9.1 Provided always that the design of an electromagnetic gauge is such that the flow range that is to be determined is contained within the space wherein the electromagnetic field strength is of uniform density, then a stable relationship may be expected between the gauge measurements [i.e. water depth, probe voltage and (if the design so requires) coil current] and the gauge determinand (flow).

9.2 The measurand/determinand relationship may take more than one form, depending upon both hydraulic and electrical circumstances at the gauge site. There may or may not need to be terms in the relationship that accommodate water depth zero datum off-set and/or probe voltage off-set. The gauge provider should indicate for the benefit of the gauge user what form of relation is appropriate in respect of a given site and design.

9.3 Once the general form of a relation is established, the optimum values for each coefficient and constant in the site-specific relation need to be established through a process of calibration. This will normally be done by making a series of independent determinations of flow (most often by repetitive current meter gauging) and noting the observed values of the gauge's measurands that are concurrently indicated.

9.4 A series of calibration determinations should be such as to have sufficient range and number to sample adequately the range of flows that the gauge is intended to accommodate and to minimize the effects of random measurement uncertainty.

9.5 The independent determinations of flow should be made with very great care, having particular regard to the hydraulic conditions at the gauge site. The objective of the calibration process should be the accrual of a sample data set wherein the total uncertainty in each independent flow measurement is, if possible, less than the concurrent combined uncertainty of the gauge's measurands.

9.6 Care shall be taken to ensure that the act of check gauging does not affect the working of the electromagnetic gauge.

9.7 Annex D gives an example calibration procedure. The target calibration gauging set is defined therein but users of the gauge may require the gauge to be calibrated over a shorter-range data set. Indeed all of the conditions listed in Annex D (Clause 8) may take several months or even years to occur. A calibration based on a reduced number or range of gaugings can be determined, until the remainder can be achieved.

9.8 Once a sufficiently numerous and range-representative calibration sample has accrued, optimal values of relation coefficients and constants may be determined by appropriate mathematical processes, which may include simple or multiple regression analysis.

9.9 Following the satisfactory completion of gauge calibration, it would be prudent to carry out occasional (for example, following a flood event) verification gauging. This would take the form of current meter gauging to a less stringent specification than that used for calibration. Such gauging results should not be used in the formulation of subsequent calibration.

Annex A (informative)

Site survey for electrical interference

When choosing a potential site for an electromagnetic gauging station, it is recommended that there be no major source of electrical interference in the proximity of the site. Typical sources include power distribution cables, radio transmitters and electric railways. The minimum distance between the power distribution cables or electric railways and the gauging station should preferably be at least 100 m. The distance from a radio station will depend on the power of that station, but generally the distance should be at least 2 km to 3 km.

In all cases, it is recommended that a survey be carried out. This survey should consist of the installation of two electrodes in the proposed positions of the flow gauge electrodes and measurement of the interference picked up by these electrodes using a battery-operated oscilloscope isolated from earth. For a guaranteed gauge operation the interference, seen as an envelope on the oscilloscope, should be less than the level of interference specified as acceptable by the gauge manufacturer.

Higher levels of interference may be acceptable since the installation of an insulating membrane will reduce the interference by an order of magnitude. However, in such circumstances the suitability of a site is doubtful and the supplier of the equipment will normally need to be consulted. The time of day and the date on which the interference measurements are made should be noted, as the level of interference may vary significantly diurnally or annually for several reasons.

If the source of interference is known to be due to electric railways, for example, measurements should be made when trains are passing in the vicinity of the proposed site. The operation of level-crossing gates has been noted to cause electrical interference and this effect should also be observed if relevant. Where the source of interference is likely to be due to a radio station, efforts should be made to establish that the particular radio station is operating at full power at the time of the survey. Where a radio telemetry outstation link is to be used, it is important to establish the level of interference likely to be caused by the telemetry transmitter.

Annex B (informative)

Design aspects of the electromagnetic coil

This International Standard does not describe the design of electromagnets. However, there are certain design parameters that need to be taken into account.

- a) The field generated by the coil shall be of sufficient strength to allow the induced voltage at minimum water velocity to be measured to the required accuracy.
- b) A second design aspect is that the vertical distribution of the field strength should be as uniform as possible.

For aspect a), the coil designer will need an estimate of the minimum water velocity and a specification of the required uncertainty at that minimum velocity.

The minimum measurable voltage is to be specified by the equipment manufacturer. However, the uncertainty of this measurement will also depend on the level of interference and the period over which averaging or integration is to be performed. Assuming the effect of interference is random, the longer the averaging period, the lower the uncertainty of the measurement at the end of it.

As a guide, it is normal to aim at a minimum induced voltage of 20 μV which may be achieved with a coil of a few hundred ampere turns.

For the second aspect, the effect of non-uniformity of the magnetic field on the uncertainty of flow measurement will depend on the presence of other factors, in particular velocity profile variations.

A coil which is wide compared with the water depth variation will have a more uniform magnetic field over the area of interest than a narrow one. Saddle-shapes or trapezoidal shapes will generally produce more uniform fields than flat coils, and coil pairs can be used to give very uniform magnetic fields between the coils.

As a guide, the vertical field variation over the water depth should be less than 1,5:1.

Annex C (informative)

Numerical example of the calculation of uncertainty

Consider an insulated channel of rectangular cross-section, of 15 m width, and having a depth of water of 1,0 m and a flow of 0,75 m³/s. The average velocity of the water will be 0,05 m/s.

The electromagnetic gauge comprises a square coil of 150 turns, having sides of 20 m, carrying a current of 3,0 A, located 1,0 m beneath the bed of the channel. The average magnetic field strength in the cross-section is calculated to be 21,9 A/m.

The electrode potential will be approximately 16 μV.

There may be dimensional errors, e.g. of the physical size of the coil, or the width of the channel, but these will produce offset errors rather than uncertainties and will be removed by calibration. This annex is concerned with the components of uncertainty rather than error:

- a) the strength of the magnetic field near the bed is 22,4 A/m, whereas that near the surface is 21,3 A/m. The average in the cross-section is 21,9 A/m, and that in the upper 0,5 m is 21,5 A/m. If, because of weed growth, all the flow occurred in the upper 0,5 m of water, the error (u_f) would be about 1,8 %. Less serious effects would apply for smaller non-uniformities of velocity profile;
- b) the uncertainty of the gauge's electronics to determine the coil current (u_e), e.g. 0,5 %;
- c) the uncertainty of the gauge's electronic circuit to determine the electrode voltage (u_c), e.g. 0,5 μV in 16 μV or 3,1 %;
- d) the uncertainty of the depth gauge to determine depth (u_g), e.g. 5 mm or 0,5 %;
- e) the uncertainty of the effective bed level (u_b) i.e. the uncertainty of the value of D_0 , e.g. 10 mm or 1 % of the 1 m depth.

These factors have substantially equal significance and the total expanded uncertainty at the 95 % confidence level, (coverage factor = 2) will be the square root of the sum of the squares of the above components, i.e.

$$\begin{aligned}
 U(q) &= \sqrt{u_f^2 + u_e^2 + u_c^2 + u_g^2 + u_b^2} \\
 &= \sqrt{1,8^2 + 0,5^2 + 3,1^2 + 0,5^2 + 1,0^2} \\
 &= 3,8 \%
 \end{aligned}$$

In this illustration, it has been assumed that there is no gradient of electrical conductivity in the water which would contribute to the uncertainty.

NOTE The above uncertainty calculation is a Type B evaluation of uncertainty, since the component uncertainties are based on previous measurements and calibration data.

Annex D (normative)

Gauge calibration procedure

D.1 A series of calibration check gaugings should be carried out to establish the constants in the flow formula [see Equation (4)]. Until this is done, a provisional formula may be programmed into the flow gauge based on calculations and models using previous experience to give a provisional flow figure as a guide. The calibration series almost inevitably is carried out over a relatively long period of time since the widest possible range of flow and depth conditions should be included. The formula may be refined as the calibration series progresses until sufficient confidence is achieved to continue with less rigorous verification checks.

D.2 All current meter gauging for calibration purposes should be undertaken within the electromagnetic gauge's cross-section. Such a position ensures that the same flow is experienced by both the electromagnetic gauge and the current meter. The ideal position would be immediately downstream of the coil since this would avoid disturbing the flow through the electromagnetic gauge by the act of current meter gauging. In some cases, the current meter can be used closer to the electrodes if this can be done with no serious disturbance. This position is best avoided if an electromagnetic current meter is being used because of the risk of electromagnetic interference.

D.3 Multi-point gauging should be adopted as the norm for calibration gaugings where sufficient depth allows. Subsequent calibration verification gaugings might, for reasons of economy, be undertaken to a lesser standard. However, no verification gauging should be considered for inclusion within a formal calibration data set. An anomalous verification gauging should trigger the execution of a further, fully-specified calibration gauging.

The target velocity sampling density for a calibration gauging should be:

a) **Spacing of verticals**

Not less than 20, evenly spaced along the line between the electrodes, or at 0,5 m intervals along the same line, whichever results in the greater number of verticals.

In small channels less than 1 m wide, this number may be reduced.

b) **Number of velocity samples in each vertical**

Subject to there being sufficient depth of water available, not less than five.

c) **Spacing of velocity samples in the vertical**

In accordance with the five-point method specified in ISO 748.

Under certain conditions, the flow may change relatively quickly. Though not ideal, it may be necessary to carry out calibration gauging under such conditions. To keep the change in flow during a gauging to a minimum, the number of samplings of velocity, may have to be reduced.

D.4 In the course of a calibration gauging steps should be taken at the outset to verify that the flow gauge is operating correctly as follows:

- a) observe that water depth is being correctly indicated; adjust the input to the gauge accordingly, if necessary;
- b) observe that displayed coil current lies within 5 % of the gauge norm (this parameter having previously been established, and being recorded in documentation resident at the gauge);
- c) observe that displayed probe voltage is stable over the gauge's averaging period (see 7.4.2).

If there is reason to believe or suppose that the gauge is not operating correctly, there is no point to a formal calibration gauging proceeding although there may be point to a verification gauging being undertaken.

Observations should be made of the flow gauge's own measurands as follows:

- immediately before gauging begins;
- immediately after gauging ends;
- more frequently when level or flow is changing rapidly.

D.5 The procedure for undertaking both formal calibration and verification gaugings at flow gauge sites should include measuring water depth independently at each vertical during the gauging. Reliance should not be placed upon pre-surveyed cross-sections to determine water depth.

D.6 As a matter of policy, calibration gauging at any given site should not be undertaken uniquely by the same personnel or uniquely using the same current meter set.

D.7 Individual gaugings should be most carefully vetted before being accepted for inclusion in a formal calibration data set. If the flow, as indicated by the electromagnetic gauge before and after the current meter gauging, has changed by more than 10 %, the gauging should be rejected.

D.8 The minimum target calibration gauging data set should have the following characteristics.

- a) It should consist of no less than 30 samples.
- b) It should be accumulated over the shortest time possible that is commensurate with achieving the target spread of samples across a station's operational ranges of flow and depth.
- c) It should contain samples from each 5-percentile of the station's operational flow range, up to the 50-percentile flow and thereafter, from each decile.
- d) It should contain samples from each 5-percentile of the station's operational depth range, up to the 50-percentile depth and thereafter, from each decile.

D.9 Once a set of calibration data has been obtained, the data should be subjected to mathematical analysis. The best values of the constants in Equation (4) will thus be obtained and a flow formula generated which may then be programmed into the electromagnetic gauge. The flow figures which would have been calculated by the gauge at the time of each of the calibration gaugings may be computed and compared with the results of the current meter gauging.

Bibliography

- [1] BEVIR, M.K. The theory of induced voltage EM flow meters. *Journal of Fluid Mechanics*, **43**, 1970, pp. 577-590

BSI — British Standards Institution

BSI is the independent national body responsible for preparing British Standards. It presents the UK view on standards in Europe and at the international level. It is incorporated by Royal Charter.

Revisions

British Standards are updated by amendment or revision. Users of British Standards should make sure that they possess the latest amendments or editions.

It is the constant aim of BSI to improve the quality of our products and services. We would be grateful if anyone finding an inaccuracy or ambiguity while using this British Standard would inform the Secretary of the technical committee responsible, the identity of which can be found on the inside front cover.
Tel: +44 (0)20 8996 9000. Fax: +44 (0)20 8996 7400.

BSI offers members an individual updating service called PLUS which ensures that subscribers automatically receive the latest editions of standards.

Buying standards

Orders for all BSI, international and foreign standards publications should be addressed to Customer Services. Tel: +44 (0)20 8996 9001.
Fax: +44 (0)20 8996 7001. Email: orders@bsi-global.com. Standards are also available from the BSI website at <http://www.bsi-global.com>.

In response to orders for international standards, it is BSI policy to supply the BSI implementation of those that have been published as British Standards, unless otherwise requested.

Information on standards

BSI provides a wide range of information on national, European and international standards through its Library and its Technical Help to Exporters Service. Various BSI electronic information services are also available which give details on all its products and services. Contact the Information Centre.
Tel: +44 (0)20 8996 7111. Fax: +44 (0)20 8996 7048. Email: info@bsi-global.com.

Subscribing members of BSI are kept up to date with standards developments and receive substantial discounts on the purchase price of standards. For details of these and other benefits contact Membership Administration.
Tel: +44 (0)20 8996 7002. Fax: +44 (0)20 8996 7001.
Email: membership@bsi-global.com.

Information regarding online access to British Standards via British Standards Online can be found at <http://www.bsi-global.com/bsonline>.

Further information about BSI is available on the BSI website at <http://www.bsi-global.com>.

Copyright

Copyright subsists in all BSI publications. BSI also holds the copyright, in the UK, of the publications of the international standardization bodies. Except as permitted under the Copyright, Designs and Patents Act 1988 no extract may be reproduced, stored in a retrieval system or transmitted in any form or by any means – electronic, photocopying, recording or otherwise – without prior written permission from BSI.

This does not preclude the free use, in the course of implementing the standard, of necessary details such as symbols, and size, type or grade designations. If these details are to be used for any other purpose than implementation then the prior written permission of BSI must be obtained.

Details and advice can be obtained from the Copyright & Licensing Manager.
Tel: +44 (0)20 8996 7070. Fax: +44 (0)20 8996 7553.
Email: copyright@bsi-global.com.