

BS ISO 9211-4:2012



BSI Standards Publication

# Optics and photonics — Optical coatings

Part 4: Specific test methods

**bsi.**

...making excellence a habit.™

**National foreword**

This British Standard is the UK implementation of ISO 9211-4:2012. It supersedes BS ISO 9211-4:2006 which is withdrawn.

The UK participation in its preparation was entrusted to Technical Committee CPW/172, Optics and Photonics.

A list of organizations represented on this committee can be obtained on request to its secretary.

This publication does not purport to include all the necessary provisions of a contract. Users are responsible for its correct application.

© The British Standards Institution 2012. Published by BSI Standards Limited 2012

ISBN 978 0 580 71407 8

ICS 37.020

**Compliance with a British Standard cannot confer immunity from legal obligations.**

This British Standard was published under the authority of the Standards Policy and Strategy Committee on 31 August 2012.

**Amendments issued since publication**

Date	Text affected
------	---------------

---

INTERNATIONAL  
STANDARD

**ISO**  
**9211-4**

Third edition  
2012-08-15

---

---

**Optics and photonics — Optical  
coatings —**

Part 4:  
**Specific test methods**

*Optique et photonique — Traitements optiques —  
Partie 4: Méthodes d'essai spécifiques*



Reference number  
ISO 9211-4:2012(E)

© ISO 2012



**COPYRIGHT PROTECTED DOCUMENT**

© ISO 2012

All rights reserved. Unless otherwise specified, no part of this publication may be reproduced or utilized in any form or by any means, electronic or mechanical, including photocopying and microfilm, without permission in writing from either ISO at the address below or ISO's member body in the country of the requester.

ISO copyright office  
Case postale 56 • CH-1211 Geneva 20  
Tel. + 41 22 749 01 11  
Fax + 41 22 749 09 47  
E-mail [copyright@iso.org](mailto:copyright@iso.org)  
Web [www.iso.org](http://www.iso.org)

Published in Switzerland

# Contents

Page

<b>Foreword</b> .....	<b>iv</b>
<b>1 Scope</b> .....	<b>1</b>
<b>2 Normative references</b> .....	<b>1</b>
<b>3 Terms and definitions</b> .....	<b>1</b>
<b>4 Test conditioning</b> .....	<b>1</b>
<b>5 Abrasion resistance tests (conditioning method 01: abrasion)</b> .....	<b>1</b>
5.1 General.....	1
5.2 Test conditions.....	2
5.3 Degree of severity (conditioning method 01: abrasion).....	2
5.4 Recovery.....	2
5.5 Evaluation.....	2
<b>6 Adhesion tests (conditioning method 02: adhesion)</b> .....	<b>3</b>
6.1 General.....	3
6.2 Test conditions.....	3
6.3 Degree of severity (conditioning method 02: adhesion).....	3
6.4 Recovery.....	3
6.5 Evaluation.....	3
<b>7 Crosshatch test (conditioning method 03: crosshatch)</b> .....	<b>4</b>
7.1 General.....	4
7.2 Test conditions.....	4
7.3 Conditioning.....	4
7.4 Recovery.....	4
7.5 Evaluation.....	4
<b>8 Solubility tests (conditioning method 04: solubility)</b> .....	<b>5</b>
8.1 General.....	5
8.2 Test conditions.....	5
8.3 Degree of severity (conditioning method 04: solubility).....	6
8.4 Recovery.....	6
8.5 Evaluation.....	6
<b>9 Environmental test code</b> .....	<b>7</b>
<b>Annex A (normative) Materials for abrasion testing of optical coatings</b> .....	<b>8</b>
<b>Annex B (normative) Cheesecloth pad, pad cover and fixture preparation for moderate abrasion testing of optical coatings</b> .....	<b>11</b>
<b>Annex C (normative) Visual examination of optical coatings</b> .....	<b>13</b>
<b>Bibliography</b> .....	<b>14</b>

## Foreword

ISO (the International Organization for Standardization) is a worldwide federation of national standards bodies (ISO member bodies). The work of preparing International Standards is normally carried out through ISO technical committees. Each member body interested in a subject for which a technical committee has been established has the right to be represented on that committee. International organizations, governmental and non-governmental, in liaison with ISO, also take part in the work. ISO collaborates closely with the International Electrotechnical Commission (IEC) on all matters of electrotechnical standardization.

International Standards are drafted in accordance with the rules given in the ISO/IEC Directives, Part 2.

The main task of technical committees is to prepare International Standards. Draft International Standards adopted by the technical committees are circulated to the member bodies for voting. Publication as an International Standard requires approval by at least 75 % of the member bodies casting a vote.

Attention is drawn to the possibility that some of the elements of this document may be the subject of patent rights. ISO shall not be held responsible for identifying any or all such patent rights.

ISO 9211-4 was prepared by Technical Committee ISO/TC 172, *Optics and photonics*, Subcommittee SC 3, *Optical materials and components*.

This third edition cancels and replaces the second edition (ISO 9211-4:2006), which has been technically revised.

ISO 9211 consists of the following parts, under the general title *Optics and photonics — Optical coatings*:

- *Part 1: Definitions*
- *Part 2: Optical properties*
- *Part 3: Environmental durability*
- *Part 4: Specific test methods*

# Optics and photonics — Optical coatings —

## Part 4: Specific test methods

### 1 Scope

ISO 9211 describes surface treatments of components and substrates, excluding ophthalmic optics (spectacles), by the application of optical coatings and gives a standard form for their specification. It defines the general characteristics and the test and measurement methods wherever necessary, but it is not intended to define the process method.

This part of ISO 9211 describes specific test procedures for coating environmental durability tests that are identified in ISO 9211-3 but not described in other normative references. They are typically performed in sequence with other environmental durability tests, as shown in ISO 9211-3:2008, Annex A.

### 2 Normative references

The following documents, in whole or in part, are normatively referenced in this document and are indispensable for its application. For dated references, only the edition cited applies. For undated references, the latest edition of the referenced document (including any amendments) applies.

ISO 48, *Rubber, vulcanized or thermoplastic — Determination of hardness (hardness between 10 IRHD and 100 IRHD)*.

ISO 9211-1, *Optics and photonics — Optical coatings — Part 1: Definitions*

ISO 29862, *Self adhesive tapes — Determination of peel adhesion properties*

### 3 Terms and definitions

For the purposes of this document, the terms and definitions given in ISO 9211-1 apply.

### 4 Test conditioning

Before and after subjecting a coated specimen (component or witness sample) to any inspection or test, the specimen shall be thoroughly cleaned as required to remove dirt, finger marks, smears, etc. Recommended storage time is at least 12 h after the coating process under ambient atmospheric conditions, or as specified between manufacturer and buyer.

### 5 Abrasion resistance tests (conditioning method 01: abrasion)

#### 5.1 General

The purpose of these tests is to evaluate to what extent the optical and mechanical properties of optical coatings on components and substrates are affected when subjected to specific abrading conditions at ambient atmospheric conditions.

## 5.2 Test conditions

### 5.2.1 General

Abrasion tests shall be conducted using a coating abrasion tester capable of meeting the requirements of 5.2 and 5.3. The length of stroke of the tester shall be approximately 20 mm when the dimensions of the specimen permit. A stroke is defined as one pass in one direction on the surface being tested. The tester shall be operated in a cycling mode. A cycle is defined as one stroke in one direction, followed by a return stroke in the opposite direction. The cycle speed shall be in the range of 30 to 90 cycles per minute. The head of the tester shall be approximately normal to the surface under test during the rubbing operation. The specimen shall be firmly held so that it does not slide during the test.

### 5.2.2 Moderate abrasion test

The rubbing head of the abrasion tester shall be covered with a pad of cotton cheesecloth conforming to A.1, approximately 5 mm thick and 10 mm wide. Instructions for preparing the cheesecloth pad, cover and fixture are provided in Annex B.

### 5.2.3 Severe abrasion test

The rubbing head of the abrasion tester shall be affixed with a standard eraser, conforming to A.2. The eraser shall be inserted into the holder so that the exposed length does not exceed 3 mm.

It is permissible to clean the eraser with a clean towel but solvents should not be used. Also, the eraser may be conditioned by rubbing it across a clean, smooth or frosted glass surface to wear away some of the rubber if embedded foreign material is suspected.

## 5.3 Degree of severity (conditioning method 01: abrasion)

The degrees of severity for conditioning method 01 are given in Table 1.

**Table 1 — Degrees of severity for conditioning method 01: abrasion**

Degree of severity	01	02	03	04
<b>Abrader</b>	Cheesecloth	Cheesecloth	Eraser	Eraser
<b>Number of strokes</b>	50	100	20	40
<b>Force</b>	5 N ± 1 N	5 N ± 1 N	10 N ± 1 N	10 N ± 1 N

A requirement for a greater number of strokes shall be indicated by adding a multiplier to the degree of severity. For example, a requirement for 150 cheesecloth rubs would be indicated as “degree of severity 01 x 3”; a requirement for 100 eraser rubs would be indicated as “degree of severity 03 x 5”.

## 5.4 Recovery

Subsequent to the rubbing operation the specimen shall be cleaned as described in Clause 4.

## 5.5 Evaluation

The film on the specimen shall be visually examined in reflected and/or transmitted light, with the unaided eye, for evidence of physical damage to the coating. The examination shall be performed using the method specified in Annex C, or that given in ISO 14997, or as agreed between the supplier and the user. The method used shall be stated. The coating shall not show any evidence of damage, such as abrasion or coating removal. If slight sleeking or scratching is visible and the cheesecloth or eraser and/or coating is suspected of having foreign material embedded in it, another area of the surface shall be retested using a fresh cheesecloth pad or eraser.



## 6 Adhesion tests (conditioning method 02: adhesion)

### 6.1 General

The purpose of these tests is to evaluate to what extent the mechanical properties of optical coatings on components and substrates are affected when subjected to specific tensile or shear stress conditions at ambient atmospheric conditions.

### 6.2 Test conditions

**6.2.1** The adhesive tape used for this test shall be clear in colour with an adhesive strength on steel of at least 9,8 N per 25 mm width when tested in accordance with ISO 29862, Method 1, 180° angle of peel. It shall be 12 mm to 13 mm wide. It shall show no evidence of deterioration and shall be capable of being unwound from the roll at a normal rate of speed without showing evidence of adhesive offsetting, adhesive splitting, or stringing out of adhesive, nor breakage or splitting of the tape backing. The tape shall be free of bare spots or foreign particles or any defect that may affect serviceability or appearance.

**6.2.2** Apply approximately 25 mm of tape to the coated surface when the dimensions of the specimen permit, with sufficient tape remaining to securely grasp with a thumb and finger.

**6.2.3** Press the tape firmly onto the coated surface. Rub the non-adhesive surface of the tape with a finger to ensure firm contact with the specimen and to work out any air bubbles that may be present.

**6.2.4** Unless otherwise required in the relevant specification, do not apply the tape within 2 mm of any rim of the specimen.

**6.2.5** Hold the specimen firmly in one hand, and in the other the end of the tape that protrudes beyond the edge of the test specimen.

**6.2.6** Remove the tape at an angle perpendicular to the coated surface at one of the rates indicated in Table 2.

### 6.3 Degree of severity (conditioning method 02: adhesion)

The degrees of severity for conditioning method 02 are given in Table 2.

**Table 2 — Degrees of severity for conditioning method 02: adhesion**

Degree of severity	01	02	03
Rate of tape removal	Slow (approximately 2 s to 3 s per 25 mm)	Quick (approximately 1 s per 25 mm)	Snap (much less than 1 s per 25 mm)
NOTE The "snap" rate of removal refers to a snapping action of the wrist and fingers.			

### 6.4 Recovery

Do not clean the specimen prior to evaluation.

### 6.5 Evaluation

The film on the specimen shall be visually examined in reflected and/or transmitted light, with the unaided eye, for evidence of coating removal. The examination shall be performed using the method specified in Annex C, or that given in ISO 14997, or as agreed between the supplier and the user. The method used shall be stated. The coating shall not show any evidence of coating removal.

Unless otherwise required in the relevant specification, visual discolourations of the coating such as stains, smears, streaks or cloudiness shall be acceptable if the specimen conforms to the optical and other environmental durability requirements of the relevant specification.

## **7 Crosshatch test (conditioning method 03: crosshatch)**

### **7.1 General**

The purpose of this test is to evaluate to what extent the adhesion properties of optical coatings on components and substrates are affected after cutting the coating (distorting the stress and influencing the adhesion).

### **7.2 Test conditions**

**7.2.1** Use a cutting device [e.g. a razor blade (suitable for soft substrates) or a diamond scribe] to make six parallel cuts in the coating,  $1,5 \text{ mm} \pm 0,5 \text{ mm}$  apart and approximately 15 mm to 20 mm in length, when the dimensions of the specimen permit. Cut through the coating completely but do not cut too deep into the substrate. Rotate the sample and in the same way make six parallel cuts perpendicular to the first set of cuts. Check the cut pattern for flakes or other irregularities and record the results.

**7.2.2** Apply adhesive tape as specified in 6.2.1 over the crosshatch pattern in accordance with 6.2.2 to 6.2.5.

### **7.3 Conditioning**

Remove the tape at an angle perpendicular to the coated surface at a snap rate (much less than 1 s per 25 mm).



### **7.4 Recovery**

Do not clean the specimen prior to evaluation.

### **7.5 Evaluation**

Rate the crosshatch results according to Table 3. Magnification may be used.

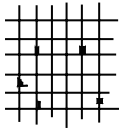
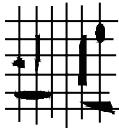
**Table 3 — Rating system for conditioning method 03: crosshatch**

Classification	Picture	Description
0	—	The edges of the cuts are completely unchanged; none of the squares are detached.
1		Small flakes of the coating are detached at the intersections; less than 5 % of the total area is affected.
2		Small flakes of the coating are detached along the cuts and the intersections; the area affected is 5 % to 15 % of the total area.
3		Some parts of the squares are detached; the area affected is 15 % to 35 % of the total area.
4		Whole squares are detached; the area affected is 35 % to 65 % of the total area.
5	—	Flaking and detachment worse than classification 4.

## 8 Solubility tests (conditioning method 04: solubility)

### 8.1 General

The purpose of these tests is to evaluate to what extent the optical and mechanical performance characteristics of optical coatings on components and substrates are affected after immersion in distilled or deionized water or a salt water solution.

### 8.2 Test conditions

**8.2.1** The test container shall be made of non-reactive material, such as suitable glass or ceramic, with a volume adequate to submerge the test part(s) completely.

**8.2.2** The specimen(s) shall be held in the test container using a specimen holder made of non-reactive material, such as polytetrafluoroethylene (PTFE) or acetal polymer.

**8.2.3** The water used for tests shall be distilled or deionized. Its resistivity shall be greater than or equal to 0,2 MΩ·cm, at a temperature of 23 °C ± 2 °C.

**8.2.4** The pH of the water or salt solution shall be between 6,5 and 7,2, measured at a temperature of 23 °C ± 2 °C. Only diluted, chemically pure hydrochloric acid or chemically pure sodium hydroxide solution shall be used to adjust the pH. The pH shall be measured either electrometrically by means of a glass electrode, or colourmetrically using bromothymol blue as an indicator.

**8.2.5** The salt water solution shall be prepared by dissolving sodium chloride in distilled or deionized water at room temperature to obtain a concentration of 45 g/l. The sodium chloride shall not contain more than 1 % impurities in total.

**8.2.6** A cyclic test consists of boiling the specimen for 2 min in either distilled or salt water and cooling it for 1 min at room temperature in distilled water.

### 8.3 Degree of severity (conditioning method 04: solubility)

The degrees of severity for conditioning method 04 are given in Table 4.

**Table 4 — Degrees of severity for conditioning method 04: solubility**

Degree of severity	Exposure time	Solution
01	6h	Distilled or deionized water
02	24 h	Distilled or deionized water
03	96 h	Distilled or deionized water
04	6 h	Salt water
05	24 h	Salt water
06	96 h	Salt water
07	5 min	Boiling distilled or deionized water
08	15 min	Boiling distilled or deionized water
09	5 min	Boiling salt water
10	15 min	Boiling salt water
11	60 min	Boiling salt water
12	2 min + 1 min	Boiling distilled or salt water <sup>a</sup> followed by distilled water at room temperature

<sup>a</sup> The user shall specify whether distilled or salt water is to be used and the number of cycles.

### 8.4 Recovery

After immersion, specimens subjected to the water solubility test shall be dried with a soft clean cloth. Specimens subjected to the salt solution shall be gently washed in distilled or deionized water not warmer than 38 °C to remove salt deposits. Specimens then shall be dried with a soft clean cloth or with filtered dry nitrogen gas.

### 8.5 Evaluation

The film on the specimen shall be visually examined in reflected and/or transmitted light, with the unaided eye, for evidence of flaking, peeling, cracking or blistering. The examination shall be performed using the method specified in Annex C, or that given in ISO 14997, or as agreed between the supplier and the user. The method used shall be stated. The coating shall not show any evidence of physical deterioration.

Unless otherwise required in the relevant specification, visual discolourations of the coating, such as stains, smears, streaks or cloudiness, shall be acceptable if the specimen conforms to the optical and other environmental durability requirements of the relevant specification.

## 9 Environmental test code

The code for coating environmental durability tests shall be formed as shown in Figure 1:

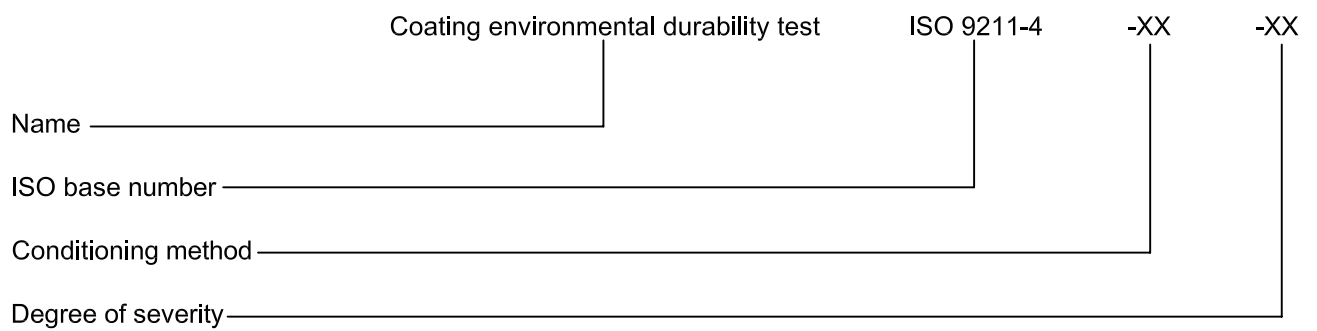

**Figure 1 — Code for coating environmental durability tests**

## Annex A (normative)

### Materials for abrasion testing of optical coatings

#### A.1 Cheesecloth material

##### A.1.1 Yarn

The yarn shall be made from cotton, free from waste and loading materials, carded, drawn and spun into single yarns.

##### A.1.2 Warp

The warp of the cloth shall have 41 yarns to 47 yarns per 25 mm and the filling shall have 33 yarns to 39 yarns per 25 mm. The total number of yarns in a 25 mm by 25 mm square shall be 76 to 84. The mass shall be 45 g/m<sup>2</sup> to 54 g/m<sup>2</sup>.

##### A.1.3 Type

The type of cheesecloth shall be bleached. Prior to use, it shall be laundered to remove completely the sizing agent and then dried.

#### A.2 Eraser (rubber-pumice) material

##### A.2.1 General

The eraser<sup>1)</sup> shall be a uniform mixture of rubber and abrasive, formed by an extrusion process. It shall be composed of no less than 15 % by mass of pumice. All abrasive shall be fine ground, such that 100 % will pass through a sieve with opening 45 µm. The formulation shall not contain any ingredient which might leave a residue on the surface under test that would lubricate subsequent strokes during the test procedure.

##### A.2.2 Hardness

The finished eraser shall have an international rubber hardness degree (IRHD) of 75 ± 5 on both ends, in accordance with ISO 48.

##### A.2.3 Accelerated aging

The eraser shall show a hardness change of not more than 10 points after being placed in an air oven for seven days at a temperature of 70 °C ± 2 °C.

##### A.2.4 Shape and size

The diameter of the eraser shall be from 6,5 mm to 7 mm, so that it fits tightly and is held by friction in an abrasion test fixture, such as that shown in Figure A.1. It shall be of sufficient length to be held securely in the abrasion test fixture with not more than 3 mm exposed.

---

1) Erasers manufactured to these requirements are available from Summers Optical, P.O. Box 162, Fort Washington, PA 19034, USA. This information is given for the convenience of users of this part of ISO 9211 and does not constitute an endorsement by ISO of this source of supply. Equivalent erasers may be available from other sources, and may be used subject to agreement between supplier and user.

### **A.2.5 Workmanship**

The eraser shall be free from any excessive holes, cracks, splits or foreign particles which might adversely affect its use.

### **A.2.6 Storage**

It is recommended that supplies of erasers are stored in a dark and dry environment (<60 % relative humidity) at a nominal temperature between 2 °C and 10 °C.

Dimensions in millimetres

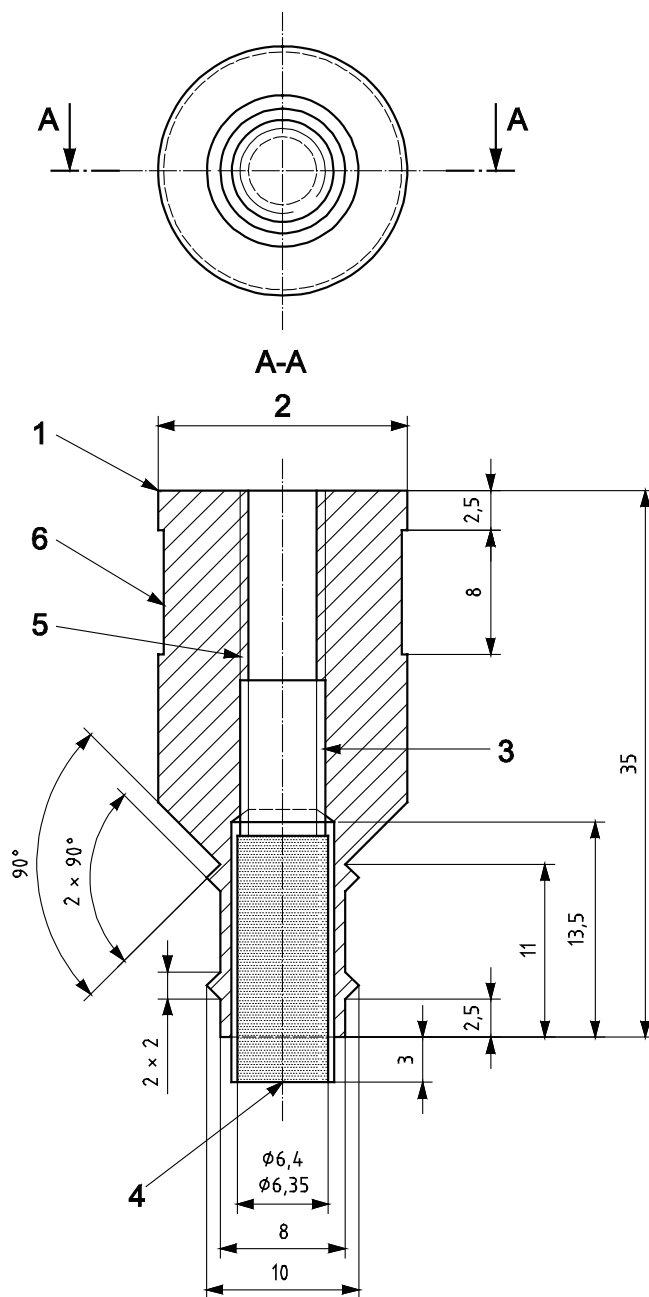

**Key**

- 1 abrasion test fixture
- 2 size to fit abrasion tester
- 3 set screw
- 4 eraser conforming to Annex A
- 5 thread for set screw
- 6 place for set screw

NOTE All dimensions except hole for the eraser are nominal and are not critical.

**Figure A.1 — Abrasion test fixture with eraser installed**



## **Annex B** **(normative)**

### **Cheesecloth pad, pad cover and fixture preparation for moderate abrasion testing of optical coatings**

#### **B.1 Cheesecloth pad preparation**

**B.1.1** Put on finger cots or latex, vinyl or nitrile gloves.

**B.1.2** Place a clean cotton towel or clean tissue paper on the work surface.

**B.1.3** Clean all tools (scissors, callipers and 11 mm diameter punch) with isopropyl alcohol (IPA) before use.

**B.1.4** Cut and arrange into a stack 32 layers of cheesecloth material that complies with A.1. The length and width of the stack should be sufficient to punch from it the number of 11 mm diameter pads that are needed. When compressed, the stack should be approximately 6 mm thick.

**B.1.5** Fold a clean piece of paper in half.

**B.1.6** Place the stacked layers of cheesecloth inside the folded piece of paper.

**B.1.7** Staple through the paper and layers at each of the four corners of the stack of cheesecloth, in order to keep them from moving out of alignment during the punching operation.

**B.1.8** Place the paper-covered cheesecloth stack on a piece of polytetrafluoroethylene or similar material and place the polytetrafluoroethylene on the workspace of a punch press.

**B.1.9** Place an 11 mm diameter hole punch on top of the paper-covered cheesecloth stack.

**B.1.10** Punch through the stack.

**B.1.11** Carefully remove the hole punch from the stack of cheesecloth.

**B.1.12** Remove the completed cheesecloth pad from the inside of the hole punch by pushing it out of the punch with a dowel or similar device.

**B.1.13** Carefully place the completed cheesecloth pad inside a clean container.

**B.1.14** Repeat steps B.1.9 to B.1.13 to cut additional cheesecloth pads as required.

#### **B.2 Cheesecloth pad cover and fixture preparation**

**B.2.1** Cut five 50 mm by 50 mm squares of cheesecloth. Two will be used as a permanent pad cover and three will be used as replaceable pad covers.

**B.2.2** Remove the paper cover ends from an 11 mm diameter cheesecloth pad and place the pad in the centre of the two squares that will be the permanent pad cover.

**B.2.3** Insert an eraser as specified in A.2 in the tip of an abrasion test fixture, leaving 3 mm of the eraser tip exposed. See Figure A.1.

**B.2.4** Centre the pad and cover under the tip of the eraser in the abrasion test fixture.

**B.2.5** Secure the cheesecloth cover firmly around shaft of the abrasion test fixture using rubber bands or a small rubber band and an 11 mm diameter rubber O-ring placed between the two ridges on the shaft.

**B.2.6** Pull the corners of the pad cover tight, equally around the periphery of the pad, in order to hold the pad in place and centred under the eraser.

**B.2.7** Tie a piece of dental floss around the shaft between the ridges to permanently hold the pad cover in place.

**B.2.8** Trim the excess cover material beyond the securing devices close to the shaft.

**B.2.9** Place the three replaceable cover layers over the pad cover.

**B.2.10** Secure the layers firmly over the pad cover using a small rubber band placed between the two ridges on the shaft. Pull the corners of the three cover layers tight, equally around the periphery of the pad.

**B.2.11** The fullest diameter of the cheesecloth tester should be approximately 12 mm diameter. The rub contact area should be approximately 10 mm diameter.

**B.2.12** As the outer replaceable cover layer wears out, is soiled, or becomes contaminated, replace all three replaceable cover layers. The permanent cover and pad should rarely, if ever, need replacing.

**B.2.13** Prior to each use, touch a piece of adhesive tape to the tip of the rubbing head to remove loose fibres and/or contaminants.

## Annex C (normative)

### Visual examination of optical coatings

Visual examination of optical coatings by this method shall be performed using two cool white 15 W fluorescent light bulbs as the light source. The viewing distance from the coated surface to the eye shall not exceed 45 cm. The coated surface shall be viewed against a black matte background. The only illumination in the inspection area shall be from the light source used for examination. This method of examination is depicted in Figure C.1.

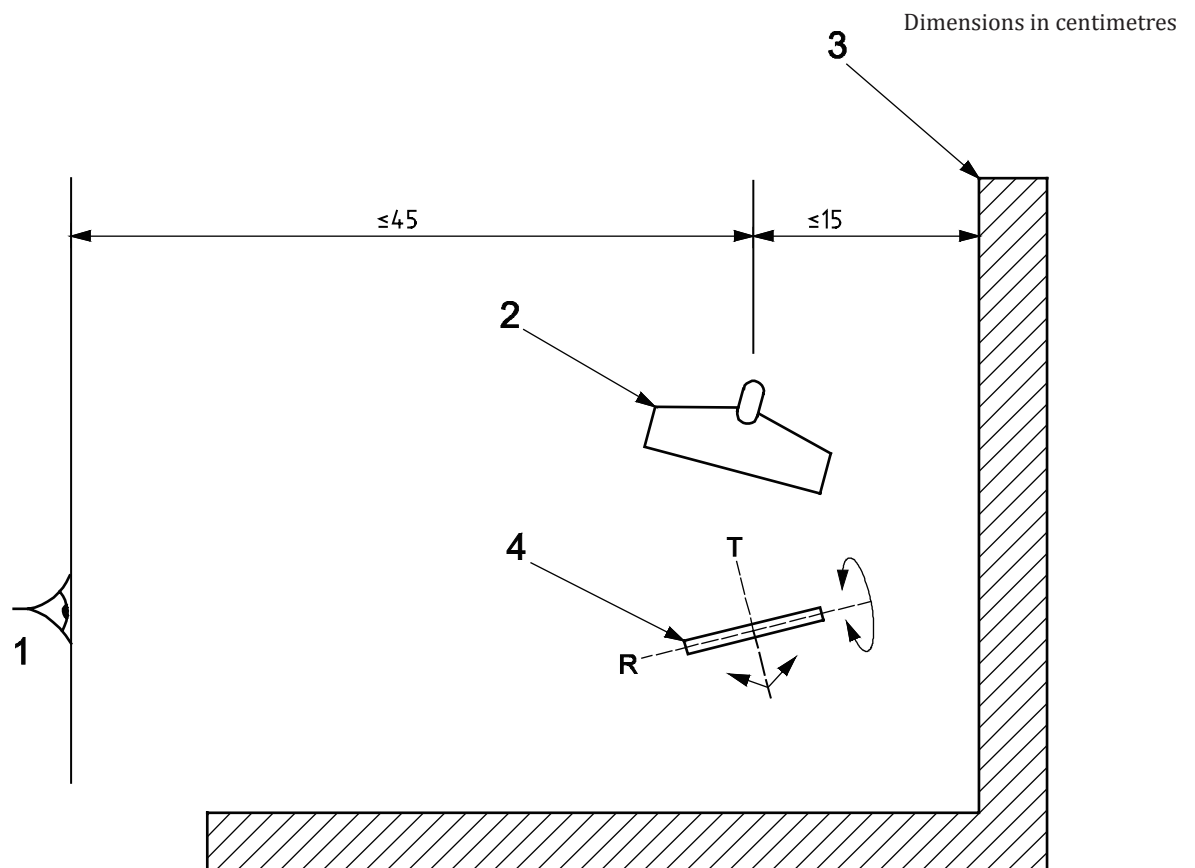

#### Key

- 1 observer
- 2 commercial fixture containing two cool white 15 W fluorescent lamps
- 3 black matte background
- 4 specimen
- R reflective viewing
- T transmissive viewing

NOTE The arrows indicate that the specimen is moved, tilted and rotated as appropriate to look for damage to the coated surface.

Figure C.1 — Method of examination

## Bibliography

- [1] ISO 9211-3, *Optics and photonics — Optical coatings — Part 3: Environmental durability*
- [2] ISO 14997, *Optics and photonics — Test methods for surface imperfections of optical elements*







# British Standards Institution (BSI)

BSI is the national body responsible for preparing British Standards and other standards-related publications, information and services.

BSI is incorporated by Royal Charter. British Standards and other standardization products are published by BSI Standards Limited.

## About us

We bring together business, industry, government, consumers, innovators and others to shape their combined experience and expertise into standards-based solutions.

The knowledge embodied in our standards has been carefully assembled in a dependable format and refined through our open consultation process. Organizations of all sizes and across all sectors choose standards to help them achieve their goals.

## Information on standards

We can provide you with the knowledge that your organization needs to succeed. Find out more about British Standards by visiting our website at [bsigroup.com/standards](http://bsigroup.com/standards) or contacting our Customer Services team or Knowledge Centre.

## Buying standards

You can buy and download PDF versions of BSI publications, including British and adopted European and international standards, through our website at [bsigroup.com/shop](http://bsigroup.com/shop), where hard copies can also be purchased.

If you need international and foreign standards from other Standards Development Organizations, hard copies can be ordered from our Customer Services team.

## Subscriptions

Our range of subscription services are designed to make using standards easier for you. For further information on our subscription products go to [bsigroup.com/subscriptions](http://bsigroup.com/subscriptions).

With **British Standards Online (BSOL)** you'll have instant access to over 55,000 British and adopted European and international standards from your desktop. It's available 24/7 and is refreshed daily so you'll always be up to date.

You can keep in touch with standards developments and receive substantial discounts on the purchase price of standards, both in single copy and subscription format, by becoming a **BSI Subscribing Member**.

**PLUS** is an updating service exclusive to BSI Subscribing Members. You will automatically receive the latest hard copy of your standards when they're revised or replaced.

To find out more about becoming a BSI Subscribing Member and the benefits of membership, please visit [bsigroup.com/shop](http://bsigroup.com/shop).

With a **Multi-User Network Licence (MUNL)** you are able to host standards publications on your intranet. Licences can cover as few or as many users as you wish. With updates supplied as soon as they're available, you can be sure your documentation is current. For further information, email [bsmusales@bsigroup.com](mailto:bsmusales@bsigroup.com).

## BSI Group Headquarters

389 Chiswick High Road London W4 4AL UK

## Revisions

Our British Standards and other publications are updated by amendment or revision.

We continually improve the quality of our products and services to benefit your business. If you find an inaccuracy or ambiguity within a British Standard or other BSI publication please inform the Knowledge Centre.

## Copyright

All the data, software and documentation set out in all British Standards and other BSI publications are the property of and copyrighted by BSI, or some person or entity that owns copyright in the information used (such as the international standardization bodies) and has formally licensed such information to BSI for commercial publication and use. Except as permitted under the Copyright, Designs and Patents Act 1988 no extract may be reproduced, stored in a retrieval system or transmitted in any form or by any means – electronic, photocopying, recording or otherwise – without prior written permission from BSI. Details and advice can be obtained from the Copyright & Licensing Department.

## Useful Contacts:

### Customer Services

**Tel:** +44 845 086 9001

**Email (orders):** [orders@bsigroup.com](mailto:orders@bsigroup.com)

**Email (enquiries):** [cservices@bsigroup.com](mailto:cservices@bsigroup.com)

### Subscriptions

**Tel:** +44 845 086 9001

**Email:** [subscriptions@bsigroup.com](mailto:subscriptions@bsigroup.com)

### Knowledge Centre

**Tel:** +44 20 8996 7004

**Email:** [knowledgecentre@bsigroup.com](mailto:knowledgecentre@bsigroup.com)

### Copyright & Licensing

**Tel:** +44 20 8996 7070

**Email:** [copyright@bsigroup.com](mailto:copyright@bsigroup.com)



...making excellence a habit.™