

BS ISO 9022-8:2015



BSI Standards Publication

# Optics and photonics — Environmental test methods

Part 8: High internal pressure, low internal  
pressure, immersion

**bsi.**

...making excellence a habit.™

**National foreword**

This British Standard is the UK implementation of ISO 9022-8:2015. It supersedes BS ISO 9022-8:1994 which is withdrawn.

The UK participation in its preparation was entrusted to Technical Committee CPW/172, Optics and Photonics.

A list of organizations represented on this committee can be obtained on request to its secretary.

This publication does not purport to include all the necessary provisions of a contract. Users are responsible for its correct application.

© The British Standards Institution 2015.  
Published by BSI Standards Limited 2015

ISBN 978 0 580 87920 3

ICS 37.020

**Compliance with a British Standard cannot confer immunity from legal obligations.**

This British Standard was published under the authority of the Standards Policy and Strategy Committee on 31 March 2015.

**Amendments/corrigenda issued since publication**

Date	Text affected
------	---------------

---

---

---

**Optics and photonics —  
Environmental test methods —**

Part 8:  
**High internal pressure, low internal  
pressure, immersion**

*Optique et photonique — Méthodes d'essais d'environnement —  
Partie 8: Pression interne élevée, pression interne faible, immersion*





**COPYRIGHT PROTECTED DOCUMENT**

© ISO 2015

All rights reserved. Unless otherwise specified, no part of this publication may be reproduced or utilized otherwise in any form or by any means, electronic or mechanical, including photocopying, or posting on the internet or an intranet, without prior written permission. Permission can be requested from either ISO at the address below or ISO's member body in the country of the requester.

ISO copyright office  
Case postale 56 • CH-1211 Geneva 20  
Tel. + 41 22 749 01 11  
Fax + 41 22 749 09 47  
E-mail [copyright@iso.org](mailto:copyright@iso.org)  
Web [www.iso.org](http://www.iso.org)

Published in Switzerland

# Contents

Page

<b>Foreword</b> .....	<b>iv</b>
<b>Introduction</b> .....	<b>vi</b>
<b>1 Scope</b> .....	<b>1</b>
<b>2 Normative references</b> .....	<b>1</b>
<b>3 General information and test conditions</b> .....	<b>1</b>
<b>4 Conditioning</b> .....	<b>1</b>
4.1 Conditioning method 80: High internal pressure.....	1
4.2 Conditioning method 81: Low internal pressure.....	1
4.3 Conditioning method 82: Immersion.....	2
<b>5 Procedure</b> .....	<b>2</b>
5.1 General.....	2
5.2 Conditioning method 82: Preconditioning of specimen and initial test.....	2
5.3 Conditioning methods 80 and 81: Pressure change curve.....	2
5.4 State of operation 2.....	3
5.5 Conditioning method 82: Recovery and final test.....	3
5.6 Conditioning method 82: Evaluation.....	3
<b>6 Environmental test code</b> .....	<b>3</b>
<b>7 Specification</b> .....	<b>3</b>
<b>Annex A (informative) Explanatory notes</b> .....	<b>5</b>

## Foreword

ISO (the International Organization for Standardization) is a worldwide federation of national standards bodies (ISO member bodies). The work of preparing International Standards is normally carried out through ISO technical committees. Each member body interested in a subject for which a technical committee has been established has the right to be represented on that committee. International organizations, governmental and non-governmental, in liaison with ISO, also take part in the work. ISO collaborates closely with the International Electrotechnical Commission (IEC) on all matters of electrotechnical standardization.

The procedures used to develop this document and those intended for its further maintenance are described in the ISO/IEC Directives, Part 1. In particular the different approval criteria needed for the different types of ISO documents should be noted. This document was drafted in accordance with the editorial rules of the ISO/IEC Directives, Part 2 (see [www.iso.org/directives](http://www.iso.org/directives)).

Attention is drawn to the possibility that some of the elements of this document may be the subject of patent rights. ISO shall not be held responsible for identifying any or all such patent rights. Details of any patent rights identified during the development of the document will be in the Introduction and/or on the ISO list of patent declarations received (see [www.iso.org/patents](http://www.iso.org/patents)).

Any trade name used in this document is information given for the convenience of users and does not constitute an endorsement.

For an explanation on the meaning of ISO specific terms and expressions related to conformity assessment, as well as information about ISO's adherence to the WTO principles in the Technical Barriers to Trade (TBT) see the following URL: [Foreword - Supplementary information](#)

The committee responsible for this document is ISO/TC 172, *Optics and photonics*, Subcommittee SC 1, *Fundamental standards*.

This second edition cancels and replaces the first edition (ISO 9022-8:1994), of which it constitutes a minor revision.

ISO 9022 consists of the following parts, under the general title *Optics and photonics — Environmental test methods*:

- *Part 1: Definitions, extent of testing*
- *Part 2: Cold, heat and humidity*
- *Part 3: Mechanical stress*
- *Part 4: Salt mist*
- *Part 6: Dust*
- *Part 7: Resistance to drip or rain*
- *Part 8: High internal pressure, low internal pressure, immersion*
- *Part 9: Solar radiation and weathering*
- *Part 11: Mould growth*
- *Part 12: Contamination*
- *Part 14: Dew, hoarfrost, ice*
- *Part 17: Combined contamination, solar radiation*
- *Part 20: Humid atmosphere containing sulfur dioxide or hydrogen sulfide*

- *Part 22: Combined cold, dry heat or temperature change with bump or random vibration*
- *Part 23: Low pressure combined with cold, ambient temperature and dry and damp heat*

## Introduction

Optical instruments are affected during their use by a number of different environmental parameters which they are required to resist without significant reduction in performance and to remain within defined specifications.

The type and severity of these parameters depend on the conditions of use of the instrument (for example, in the laboratory or workshop) and on its geographical location. The environmental effects on optical instrument performance in the tropics and subtropics are totally different from those found when they are used in arctic regions. Individual parameters cause a variety of different and overlapping effects on instrument performance.

The manufacturer attempts to ensure, and the user naturally expects, that instruments will resist the likely rigours of their environment throughout their life. This expectation can be assessed by exposure of the instrument to a range of simulated environmental parameters under controlled laboratory conditions. The severity of these conditions is often increased to obtain meaningful results in a relatively short period of time.

In order to allow assessment and comparison of the response of optical instruments to appropriate environmental conditions, ISO 9022 contains details of a number of laboratory tests which reliably simulate a variety of different environments. The tests are based largely on IEC standards, modified where necessary to take into account features special to optical instruments.

As a result of continuous progress in all fields, optical instruments are no longer only precision-engineered optical products, but, depending on their range of application, also contain additional assemblies from other fields. For this reason, the principal function of the instrument is to be assessed to determine which International Standard should be used for testing. If the optical function is of primary importance, then ISO 9022 is applicable, but if other functions take precedence, then the appropriate International Standard in the field concerned should be applied. Cases can arise where application of both ISO 9022 and other appropriate International Standards will be necessary.



# Optics and photonics — Environmental test methods —

## Part 8:

# High internal pressure, low internal pressure, immersion

## 1 Scope

This part of ISO 9022 specifies the methods relating to the environmental tests of optical instruments including additional assemblies from other fields (e.g. mechanical, chemical, and electronic devices), under equivalent conditions, for their ability to resist the influence of high pressure, low pressure, or immersion.

The purpose of testing is to investigate to what extent the optical, climatic, mechanical, chemical, and electrical performance characteristics of the specimen are affected by high pressure, low pressure, or immersion.

## 2 Normative references

The following documents, in whole or in part, are normatively referenced in this document and are indispensable for its application. For dated references, only the edition cited applies. For undated references, the latest edition of the referenced document (including any amendments) applies.

ISO 9022-1, *Optics and photonics — Environmental test methods — Part 1: Definitions, extent of testing*

## 3 General information and test conditions

The following are the three different test methods used to test the pressure-resistance of optical instruments:

- conditioning method 80: high internal pressure;
- conditioning method 81: low internal pressure;
- conditioning method 82: immersion.

Environmental conditions for conditioning method 80: clean dry air or dry nitrogen, relative humidity less than 30 %. Conditioning method 82 shall be used for instruments that might undergo immersion during service. The immersion test shall be carried out in an open water container or in a water pressure chamber using softened or demineralized water. The immersion depth specified relates to the uppermost point of the specimen. The water temperature shall be between 10 °C and 25 °C. During exposure, the temperature of the specimen shall not be lower than the water temperature nor shall it exceed that temperature by more than 10 K.

## 4 Conditioning

### 4.1 Conditioning method 80: High internal pressure

See [Table 1](#).

### 4.2 Conditioning method 81: Low internal pressure

See [Table 2](#).

### 4.3 Conditioning method 82: Immersion

See [Table 3](#).

**Table 1 — Degrees of severity for conditioning method 80: High internal pressure**

Degree of severity	01	02	03	04	05	06	07	08	09	10	11	12	13
Difference from ambient pressure hPa	100 ± 2						400 ± 5						
Maximum pressure drop hPa	75	50	20	10	5	2	300	200	100	50	20	10	5
Exposure time min	10												
State of operation	1 or 2 <sup>a</sup>												

<sup>a</sup> See 5.4.

**Table 2 — Degrees of severity for conditioning method 81: Low internal pressure**

Degree of severity	01	02	03	04	05	06	07	08	09	10	11	12	13
Difference from ambient pressure hPa	100 ± 2						400 ± 5						
Maximum pressure drop hPa	75	50	20	10	5	2	300	200	100	50	20	10	5
Exposure time min	10												
State of operation	1 or 2 <sup>a</sup>												

<sup>a</sup> See 5.4.

**Table 3 — Degree of severity for conditioning method 82: Immersion**

Degree of severity	01	02	03	04	05	06
Immersion depths m	1	4	10	50	200	400
	Allowable deviation ±10 %					
Exposure time h	2					
State of operation	1 or 2					

## 5 Procedure

### 5.1 General

The test shall be conducted in accordance with the requirements of the relevant specification and with ISO 9022-1.

### 5.2 Conditioning method 82: Preconditioning of specimen and initial test

Prior to exposure, the specimen shall be conditioned at a temperature of 40 °C ± 2 °C and a relative humidity of less than 40 % for a period of 4 h.

### 5.3 Conditioning methods 80 and 81: Pressure change curve

If required by the relevant specification, a graphical representation of the pressure change time history shall be recorded during testing. In the event that a suitable recorder is not available, the pressure change curve shall be plotted from not less than 10 values measured at equal intervals (see [Annex A](#)).

## 5.4 State of operation 2

If, in the relevant specification, state of operation 2 is required for conditioning methods 80 and 81, the following points shall be taken into consideration:

- a) thermal changes within or on the specimen shall not exceed 1 K as, otherwise, the required measurement accuracy will be degraded;
- b) mechanical motions may be initiated from the outside (e.g. manually) thus, replacing state of operation 2;
- c) in the event that mechanical motion causes changes of volume with the specimen, the resulting discontinuities in the recording of the event shall be identified.

## 5.5 Conditioning method 82: Recovery and final test

After completion of exposure, the specimen shall be conditioned at a temperature of  $40\text{ °C} \pm 2\text{ °C}$  and a relative humidity of less than 40 % for a period of 4 h and then assessed in accordance with [5.6](#).

## 5.6 Conditioning method 82: Evaluation

Initial and final tests should not reveal moisture film on optical surfaces. Moisture film will be acceptable provided that it disappears during heating of the specimen and does not reappear within 24 h after completion of the test. The results of specimen evaluation shall be compared in accordance with [5.2](#) and [5.5](#). The relevant specification shall specify acceptable differences.

If, on account of the specimen design (e.g. closed casing), a visual inspection cannot reveal penetration of water, the relevant specification shall specify a method of detecting penetrated moisture.

## 6 Environmental test code

The environmental test code shall be as defined in ISO 9022-1, giving a reference to ISO 9022 and the codes for the conditioning method chosen, the degree of severity, and the state of operation.

**EXAMPLE** The environmental test of optical instruments for pressure-resistance in the event of internal low pressure, conditioning method 81, degree of severity 01, state of operation 1, is identified as:

**Environmental test ISO 9022-81-01-1**

## 7 Specification

The relevant specification shall contain the following details:

- a) environmental test code;
- b) number of specimens;
- c) preconditioning (see [5.2](#));
- d) type and scope of initial test (see [5.2](#));
- e) conditioning methods 80 and 81: if recording of a pressure change curve in accordance with [5.3](#) is required, criteria for evaluation;
- f) state of operation 2: period of operation;
- g) state of operation 2: type and scope of intermediate test;
- h) recovery (see [5.5](#));

- i) type and scope of final test (see [5.5](#));
- j) criteria for evaluation (see [5.6](#));
- k) type and scope of test report.

## Annex A (informative)

### Explanatory notes

For the sake of satisfactory functioning, it is essential that changes of temperature do not cause moisture films on internal surfaces since, otherwise, the optical performance would be considerably degraded and other effects such as corrosion or mould growth might be accelerated. This requirement can normally be satisfied by sealing the instrument before use with dry air or nitrogen and by defining the pressure-resistance of the instrument.

Therefore, in order to ensure proper functioning, it is necessary to investigate the pressure-resistance. Depending upon the air volume of the instrument and the number of enclosure interfaces or the functional bushings inserted into the enclosure wall (in other words, depending upon the number and type of enclosure sealings), reasonable pressure-resistance requirements need to be selected and defined choosing a mission-orientated environment and conditioning method.

Instruments used and transported and thus exposed to maximum stress in high-altitude environments therefore have to be pressure-tested at high internal pressure whereas instruments which are exposed to maximum stress in environments of low temperature or high external pressure have to be pressure-tested at low internal pressure (testing at low internal pressure also presents a higher degree of safety from contamination and increased internal humidity).

Skin diving or underwater instruments shall be immersion-tested.

Recording the pressure/time history from discrete data measured during testing at high internal pressure (conditioning method 80) or low internal pressure (conditioning method 81) permits an appropriate interpretation of the tightness measured and a reasonable determination of the expected service reliability.

The use of piezoelectric or piezoresistive pressure transducers, together with the associated measuring amplifiers, ensures a high degree of measurement accuracy. Wherever possible, the sensor should be installed within the test adapter in order to avoid air volumes outside the specimen. Moreover, this arrangement facilitates the connection of a recording unit (e.g. an X-T-recorder) thus, enabling immediate charting.

A schematic representation of a pressure test apparatus for test methods 80 and 81 is given in [Figure A.1](#).

[Figure A.2](#) shows a test connection for the pressure test.

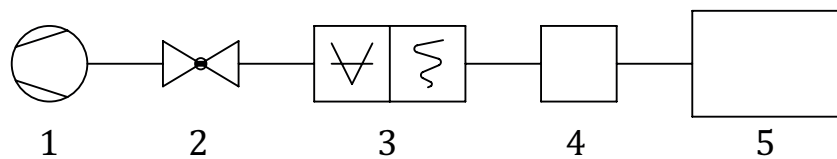

**Key**

- 1 pump
- 2 valve
- 3 vacuum-sensor with read-out and charting
- 4 test adapter
- 5 specimen

**Figure A.1 — Schematic representation of pressure test apparatus suitable for test methods 80 and 81**

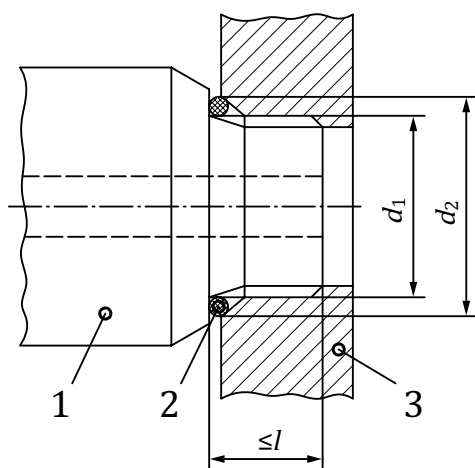

**Key**

- 1 test adapter
- 2 O-ring gasket
- 3 specimen

NOTE See [Table A.1](#) for thread values.

**Figure A.2 — Test connection for pressure test**

**Table A.1 — Thread values of test connection for pressure test**

Dimensions in millimetres

Thread $d_1$	M3	M6	M10	M16 × 1,5 <sup>a</sup>	M24 × 1,5 <sup>a</sup>	M36 × 1,5 <sup>a</sup>
$d_2$	6	9	14	21	29	42
$l$	5	8	12	15		
<sup>a</sup> Desiccator cartridge connection.						









# British Standards Institution (BSI)

BSI is the national body responsible for preparing British Standards and other standards-related publications, information and services.

BSI is incorporated by Royal Charter. British Standards and other standardization products are published by BSI Standards Limited.

## About us

We bring together business, industry, government, consumers, innovators and others to shape their combined experience and expertise into standards-based solutions.

The knowledge embodied in our standards has been carefully assembled in a dependable format and refined through our open consultation process. Organizations of all sizes and across all sectors choose standards to help them achieve their goals.

## Information on standards

We can provide you with the knowledge that your organization needs to succeed. Find out more about British Standards by visiting our website at [bsigroup.com/standards](http://bsigroup.com/standards) or contacting our Customer Services team or Knowledge Centre.

## Buying standards

You can buy and download PDF versions of BSI publications, including British and adopted European and international standards, through our website at [bsigroup.com/shop](http://bsigroup.com/shop), where hard copies can also be purchased.

If you need international and foreign standards from other Standards Development Organizations, hard copies can be ordered from our Customer Services team.

## Subscriptions

Our range of subscription services are designed to make using standards easier for you. For further information on our subscription products go to [bsigroup.com/subscriptions](http://bsigroup.com/subscriptions).

With **British Standards Online (BSOL)** you'll have instant access to over 55,000 British and adopted European and international standards from your desktop. It's available 24/7 and is refreshed daily so you'll always be up to date.

You can keep in touch with standards developments and receive substantial discounts on the purchase price of standards, both in single copy and subscription format, by becoming a **BSI Subscribing Member**.

**PLUS** is an updating service exclusive to BSI Subscribing Members. You will automatically receive the latest hard copy of your standards when they're revised or replaced.

To find out more about becoming a BSI Subscribing Member and the benefits of membership, please visit [bsigroup.com/shop](http://bsigroup.com/shop).

With a **Multi-User Network Licence (MUNL)** you are able to host standards publications on your intranet. Licences can cover as few or as many users as you wish. With updates supplied as soon as they're available, you can be sure your documentation is current. For further information, email [bsmusales@bsigroup.com](mailto:bsmusales@bsigroup.com).

## BSI Group Headquarters

389 Chiswick High Road London W4 4AL UK

## Revisions

Our British Standards and other publications are updated by amendment or revision.

We continually improve the quality of our products and services to benefit your business. If you find an inaccuracy or ambiguity within a British Standard or other BSI publication please inform the Knowledge Centre.

## Copyright

All the data, software and documentation set out in all British Standards and other BSI publications are the property of and copyrighted by BSI, or some person or entity that owns copyright in the information used (such as the international standardization bodies) and has formally licensed such information to BSI for commercial publication and use. Except as permitted under the Copyright, Designs and Patents Act 1988 no extract may be reproduced, stored in a retrieval system or transmitted in any form or by any means – electronic, photocopying, recording or otherwise – without prior written permission from BSI. Details and advice can be obtained from the Copyright & Licensing Department.

## Useful Contacts:

### Customer Services

**Tel:** +44 845 086 9001

**Email (orders):** [orders@bsigroup.com](mailto:orders@bsigroup.com)

**Email (enquiries):** [cservices@bsigroup.com](mailto:cservices@bsigroup.com)

### Subscriptions

**Tel:** +44 845 086 9001

**Email:** [subscriptions@bsigroup.com](mailto:subscriptions@bsigroup.com)

### Knowledge Centre

**Tel:** +44 20 8996 7004

**Email:** [knowledgecentre@bsigroup.com](mailto:knowledgecentre@bsigroup.com)

### Copyright & Licensing

**Tel:** +44 20 8996 7070

**Email:** [copyright@bsigroup.com](mailto:copyright@bsigroup.com)



...making excellence a habit.™