

BS ISO 8820-5:2015



BSI Standards Publication

Road vehicles — Fuse-links

Part 5: Fuse-links with axial terminals (Strip fuse-links) Types SF 30 and SF 51 and test fixtures

bsi.

...making excellence a habit.™

National foreword

This British Standard is the UK implementation of ISO 8820-5:2015. It supersedes BS ISO 8820-5:2007 which is withdrawn.

The UK participation in its preparation was entrusted to Technical Committee AUE/16, Data Communication (Road Vehicles).

A list of organizations represented on this committee can be obtained on request to its secretary.

This publication does not purport to include all the necessary provisions of a contract. Users are responsible for its correct application.

© The British Standards Institution 2015.
Published by BSI Standards Limited 2015

ISBN 978 0 580 81233 0
ICS 43.040.10; 43.180

Compliance with a British Standard cannot confer immunity from legal obligations.

This British Standard was published under the authority of the Standards Policy and Strategy Committee on 31 March 2015.

Amendments/corrigenda issued since publication

Date	Text affected
------	---------------

INTERNATIONAL
STANDARD

ISO
8820-5

Second edition
2015-03-15

Road vehicles — Fuse-links —

Part 5:

**Fuse-links with axial terminals (Strip
fuse-links) Types SF 30 and SF 51 and
test fixtures**

Véhicules routiers — Liaisons fusibles —

*Partie 5: Liaisons fusibles avec languettes axiales (liaisons fusibles
électriques) des types SF 30 et SF 51, et montages d'essai*



Reference number
ISO 8820-5:2015(E)

© ISO 2015



COPYRIGHT PROTECTED DOCUMENT

© ISO 2015

All rights reserved. Unless otherwise specified, no part of this publication may be reproduced or utilized otherwise in any form or by any means, electronic or mechanical, including photocopying, or posting on the internet or an intranet, without prior written permission. Permission can be requested from either ISO at the address below or ISO's member body in the country of the requester.

ISO copyright office
Case postale 56 • CH-1211 Geneva 20
Tel. + 41 22 749 01 11
Fax + 41 22 749 09 47
E-mail copyright@iso.org
Web www.iso.org

Published in Switzerland

Contents

Page

Foreword	iv
1 Scope	1
2 Normative references	1
3 Terms and definitions	1
4 Marking, labelling, and colour coding	1
5 Tests and requirements	2
5.1 General.....	2
5.1.1 General test conditions.....	2
5.1.2 Test sequence.....	3
5.1.3 Test cable sizes.....	3
5.2 Voltage drop.....	4
5.2.1 Purpose.....	4
5.2.2 Test.....	4
5.2.3 Requirement.....	4
5.3 Transient current cycling.....	5
5.3.1 Purpose.....	5
5.3.2 Test.....	5
5.3.3 Requirement.....	6
5.4 Environmental conditions.....	6
5.5 Operating time rating.....	6
5.5.1 Purpose.....	6
5.5.2 Test.....	6
5.5.3 Requirements.....	6
5.6 Current steps.....	7
5.6.1 Purpose.....	7
5.6.2 Test.....	7
5.6.3 Requirements.....	7
5.7 Breaking capacity.....	7
5.7.1 Purpose.....	7
5.7.2 Test.....	7
5.7.3 Requirement.....	8
5.8 Strength of terminals.....	8
5.8.1 Purpose.....	8
5.8.2 Test.....	8
5.8.3 Requirement.....	8
6 Dimensions and designation examples	9
6.1 Type SF 30.....	9
6.1.1 Dimensions.....	9
6.1.2 Designation example.....	9
6.2 Type SF 51.....	10
6.2.1 Dimensions.....	10
6.2.2 Designation example.....	10
7 Test fixture	10
7.1 General.....	10
7.2 Materials and dimensions.....	10
Bibliography	15

Foreword

ISO (the International Organization for Standardization) is a worldwide federation of national standards bodies (ISO member bodies). The work of preparing International Standards is normally carried out through ISO technical committees. Each member body interested in a subject for which a technical committee has been established has the right to be represented on that committee. International organizations, governmental and non-governmental, in liaison with ISO, also take part in the work. ISO collaborates closely with the International Electrotechnical Commission (IEC) on all matters of electrotechnical standardization.

The procedures used to develop this document and those intended for its further maintenance are described in the ISO/IEC Directives, Part 1. In particular the different approval criteria needed for the different types of ISO documents should be noted. This document was drafted in accordance with the editorial rules of the ISO/IEC Directives, Part 2 (see www.iso.org/directives).

Attention is drawn to the possibility that some of the elements of this document may be the subject of patent rights. ISO shall not be held responsible for identifying any or all such patent rights. Details of any patent rights identified during the development of the document will be in the Introduction and/or on the ISO list of patent declarations received (see www.iso.org/patents).

Any trade name used in this document is information given for the convenience of users and does not constitute an endorsement.

For an explanation on the meaning of ISO specific terms and expressions related to conformity assessment, as well as information about ISO's adherence to the WTO principles in the Technical Barriers to Trade (TBT) see the following URL: [Foreword - Supplementary Information](#)

The committee responsible for this document is ISO/TC 22, *Road vehicles*, Subcommittee SC 3, *Electric and electronic equipment*.

This second edition cancels and replaces the first edition (ISO 8820-5:2007), which has been technically revised.

ISO 8820 consists of the following parts, under the general title *Road vehicles — Fuse-links*:

- *Part 1: Definitions and general test requirements*
- *Part 2: User guidelines*
- *Part 3: Fuse-link with tabs (blade type) Type C (medium), Type E (high current) and Type F (miniature)*
- *Part 4: Fuse-links with female contacts (type A) and bolt-in contacts (type B) and their test fixtures*
- *Part 5: Fuse-links with axial terminals (Strip fuse-links) Types SF 30 and SF 51 and test fixtures*
- *Part 6 Single-bolt fuse-links*
- *Part 7: Fuse-links with tabs (Type G) with rated voltage of 450 V*
- *Part 8: Fuse-links with bolt-in contacts (Type H and J) with rated voltage of 450 V*
- *Part 9: Fuse-links with shortened tabs (Type K)*
- *Part 10: Fuse-links with tabs Type L (high current miniature)*

Road vehicles — Fuse-links —

Part 5:

Fuse-links with axial terminals (Strip fuse-links) Types SF 30 and SF 51 and test fixtures

1 Scope

This part of ISO 8820 specifies fuse-links with axial terminals (Strip fuse-links) Type SF 30 and SF 51 and test fixtures for fuses in road vehicles. It establishes, for these fuse-link types, the rated current, test procedures, performance requirements, and dimensions.

This part of ISO 8820 is applicable to fuse-links with a rated voltage of 32 V, a current rating of 30 A to 500 A, and a breaking capacity of 2 000 A intended for use in the electrical system of road vehicles with a nominal voltage of 12 V and/or 24 V.

This part of ISO 8820 is intended to be used in conjunction with ISO 8820-1 and with ISO 8820-2. The numbering of its Clauses corresponds to that of ISO 8820-1, whose requirements are applicable except where modified by requirements particular to this part of ISO 8820.

2 Normative references

The following documents, in whole or in part, are normatively referenced in this document and are indispensable for its application. For dated references, only the edition cited applies. For undated references, the latest edition of the referenced document (including any amendments) applies.

ISO 4017, *Fasteners — Hexagon head screws — Product grades A and B*

ISO 4032, *Hexagon regular nuts (style 1) — Product grades A and B*

ISO 7089, *Plain washers — Normal series — Product grade A*

ISO 8820-1, *Road vehicles — Fuse-links — Part 1: Definitions and general test requirements*

ISO 8820-2, *Road vehicles — Fuse-links — Part 2: User guidelines*

3 Terms and definitions

For the purposes of this document, the terms and definitions given in ISO 8820-1 apply.

4 Marking, labelling, and colour coding

The requirements given in [Table 1](#) and ISO 8820-1 shall apply.

Table 1 — Fuse-link colour coding

Fuse-link current rating A	Fuse-link type SF 30	Fuse-link type SF 51
30	orange	X
40	green	
50	red	
60	yellow	
70	brown	
80	white	red
100	blue	yellow
125	pink	green
150	grey	orange
175	light brown (tan)	white
200	violet	blue
225	X	light brown (tan)
250		pink
300		grey
350		dark green
400		violet
450		gold/dark yellow
500		brown

5 Tests and requirements

5.1 General

5.1.1 General test conditions

In addition to carrying out the test procedures in accordance with ISO 8820-1, the following criteria shall apply:

- tests shall be performed following the test sequences in [Table 2](#);
- the test fixtures for electrical tests shall be designed in accordance with [Figure 4](#) to [Figure 7](#). The connection resistance shall be a maximum of 1,0 mΩ for SF 30 fuse-links and a maximum of 0,35 mΩ for SF 51 fuse-links to ensure the proper function of the test fixture;
- terminals shall have a suitable finish which will ensure corrosion protection and shall have satisfactory mechanical and electrical properties.

Fuse-link type SF 30 with a rated current of 150 A...200 A and fuse-link type SF 51 with a rated current of 300 A ... 500 A shall only be used for short circuit protection and have to be tested with a cable, the insulation of which will withstand the test without deterioration.

5.1.2 Test sequence

Table 2 — Test sequence

No	Test	Clause	Sample groups ^a							
			1	2	3	4	5	6	7	
1	Dimensions	6	X	X	X					
2	Marking, labelling, and colour coding	4	X	X	X	X	X	X	X	
3	Terminal strength	5.8	X	X	X	X	X	X	X	
4	Fuse-link voltage drop	5.2	X	X	X					
5	Climatic load	5.4				X				
6	Chemical load	5.4					X			
7	Mechanical load	5.4						X		
8	Transient current cycling	5.3							X	
9	Fuse-link voltage drop	5.2				X	X	X	X	
10	Current step	5.6			X					
11	Breaking capacity	5.7	X							
12	Operating time rating	5.5	0,75 I_R , 1,0 I_R , or 1,1 I_R		X		X	X	X	X
			1,35 I_R or 1,5 I_R		Y ^b		Y	Y	Y	Y
			2,0 I_R		Y		Y	Y	Y	Y
			3,0 I_R or 3,5 I_R		Y		Y	Y	Y	Y
			5,0 I_R or 6,0 I_R		Y		Y	Y	Y	Y
13	Terminal strength (removal)	5.8	X	X	X	X	X	X	X	

^a Each sample group shall contain a minimum of eight fuse links.

^b For these operating time tests noted with a Y, the sample groups 2, 4, 5, 6, and 7 each current rating shall be divided equally. These fuses are intended to be subjected to a single operating time test only.

5.1.3 Test cable sizes

Test cable sizes shall be as given in [Table 3](#). All tests for a particular fuse-link rating shall be performed using the same cable size.

Test cable sizes are specified to allow comparative fuse-link tests to be carried out. The cable size specified does not necessarily indicate the size of cable to be used in the vehicle application.

Table 3 — Test cable sizes

Current rating A	Conductor cross sectional area ^a mm ²	
	for fuse-link types SF 30	fuse-link types SF 51
30	2,5	X
40	4,0	
50	6,0	
60		
70	10,0	
80		10,0
100	16,0	16,0
125	25,0	25,0
150		35,0
175		
200		50,0
225		
250	X	70,0
300		
350		
400		
450		
500		

^a Conductor material according ISO 6722.

5.2 Voltage drop

5.2.1 Purpose

This test defines and measures the energy consumption of the fuse-link which creates a temperature rise.

5.2.2 Test

The test given in ISO 8820-1 shall apply. Measure the voltage drop at the points as indicated (see [Figure 4](#) to [Figure 6](#)) using the test fixtures of [Clause 7](#).

This test shall be performed at 0,75 I_R for the following:

- SF 30 - 150A ... 200 A;
- SF 51 - 300 A ... 500A.

5.2.3 Requirement

The requirements given in [Table 4](#) shall apply.

Table 4 — Voltage drop

Current rating A	Max voltage drop mV		
	for fuse-link types SF 30	for fuse-link types SF 51	
30	105	X	
40	90		
50	80		
60			
70			
80	75	110	
100			
125			
150			
175	70		
200			
225			
250	X		80
300			
350			
400			
450			
500			

5.3 Transient current cycling

5.3.1 Purpose

This test evaluates the ability of the fuse-link to withstand the energy volume of transient pulses.

5.3.2 Test

[Figure 1](#) and the test given in ISO 8820-1 shall apply. At an elapsed time of 0,025 s on time, the current shall fall to a value between $1,65 I_R$ and $2,5 I_R$. At no time shall the steady-state current fall below $0,9 I_R$.

This test does not apply to fuse-links type SF 30 current ratings of 150 A and above and type SF 51 current ratings of 300 A and above. For those fuse-links, agreements have to be taken between manufacturer and supplier.

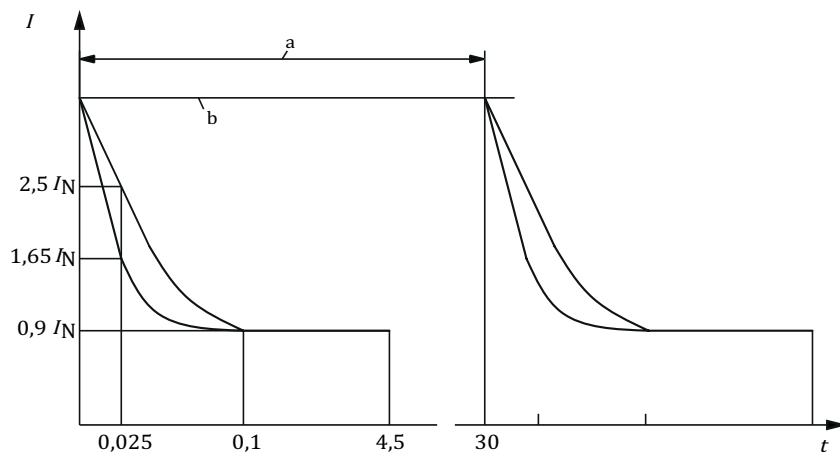

Key

I current

t time in s

a One cycle.

b Initial applied current $4,0 I_R$.

Figure 1 — Transient current cycling

5.3.3 Requirement

The requirements given in ISO 8820-1 shall apply.

5.4 Environmental conditions

The tests and requirements given in ISO 8820-1 shall apply

5.5 Operating time rating

5.5.1 Purpose

This test evaluates the ability of the fuse-links to function when subjected to electrical overloads.

5.5.2 Test

The test given in ISO 8820-1 shall apply.

5.5.3 Requirements

The requirements given in [Table 5](#) shall apply.

After activation, the current through the fuse-link shall not exceed 0,5 mA at the rated voltage of the fuse-link.

Table 5 — Operating times

Test currents	Operating times s							
	SF 30				SF 51			
	30 A ... 125 A		150 A ... 200 A		80 A ... 250 A		300 A ... 500 A	
	min	max	min	max	min	max	min	max
0,75 I_R	— ^b	—	360 000	∞	—	—	14 400	∞
I_R	360 000	∞	—	—	14 400	∞	—	—
1,1 I_R	14 400	∞	—	—	—	—	—	—
1,35 I_R	—	—	—	—	120	1 800	—	—
1,5 I_R	90	3 600	—	—	—	—	—	—
2,0 I_R	3	100	1	15	1	15	1	15
3,0 I_R	0,3	3	—	—	—	—	—	—
3,5 I_R	—	—	0,3	5	0,3	5	0,5	5
5,0 I_R	0,1	1	—	—	—	—	—	—
6,0 I_R^a	—	—	0,1	1	0,1	1	0,1	1

^a Not for ≥ 350 A.
^b Not specified.

5.6 Current steps

5.6.1 Purpose

This test evaluates the ability of the fuse-links' components to withstand the prolonged heating due to low level overloads.

5.6.2 Test

The test given in ISO 8820-1 shall apply.

NOTE This test does not apply for fuse types SF 30 – 150 A to 200 A ... SF 51 – 300 A ... 500 A.

5.6.3 Requirements

The requirement given in ISO 8820-1 shall apply. After activation, the current through the fuse-link shall not exceed 0,5 mA at the rated voltage of the fuse-link.

5.7 Breaking capacity

5.7.1 Purpose

This test evaluates the ability of the fuse-links to withstand the rated breaking current.

5.7.2 Test

The test given in ISO 8820-1 shall apply.

Test at 2 000 A with cable sizes as shown in [Table 3](#).

5.7.3 Requirement

The requirement given in ISO 8820-1 shall apply. After the test, the current through the fuse-link shall not exceed 0,5 mA at the rated voltage of the fuse-link.

5.8 Strength of terminals

5.8.1 Purpose

This test evaluates the ability of the fuse-links to withstand mechanical stress during insertion and removal.

5.8.2 Test

Install the fuse-links in the test fixture (see [Figure 4](#) to [Figure 6](#)) with the mounting torque according to [Table 6](#). This test is performed without cables and terminals.

Table 6 — Mounting torque

Fuse-link type	Mounting torque Nm
SF 30 – for M5 bolts	4,5 ± 1
SF 30 – for M6 bolts	6 ± 1
SF 51 – for M8 bolts	12 ± 1

For mounting in the vehicle, the specific procedure (greasing, surface materials, surface roughness, etc.) shall be agreed upon between the fuse-manufacturer, the fuse-box manufacturer, and the vehicle manufacturer.

NOTE Test number 13 in [Table 2](#) is just a removal from the test fixture.

5.8.3 Requirement

Fuse-links shall remain physically intact.

6 Dimensions and designation examples

6.1 Type SF 30

6.1.1 Dimensions

Dimensions in millimetres

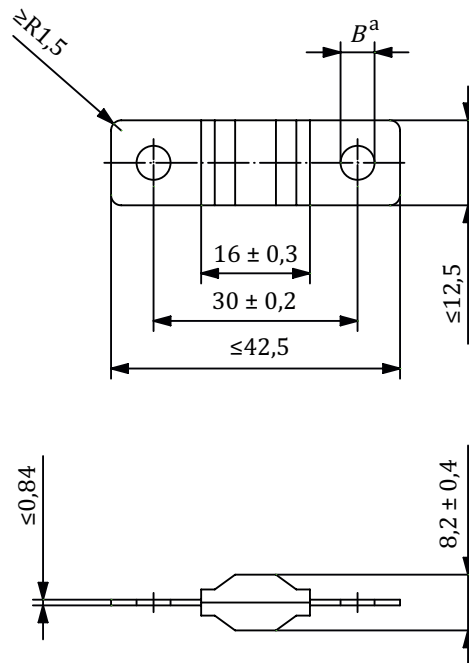

Key

B For fuse links with rated current ≤ 125 A, the hole B is for a bolt diameter of M5 and/or M6 and for fuse-links with a rated current > 125 A, the hole B is for a bolt diameter of M6

NOTE SF 30 fuses might have a hole which fits for a bolt diameter M5 or M6.

Figure 2 — Fuse-link type SF 30

6.1.2 Designation example

An example of the designation of a fuse-link type SF 30 for a rated current of 100 A and M6 bolt is

Fuse ISO 8820-SF 30-100-M6

6.2 Type SF 51

6.2.1 Dimensions

Dimensions in millimetres

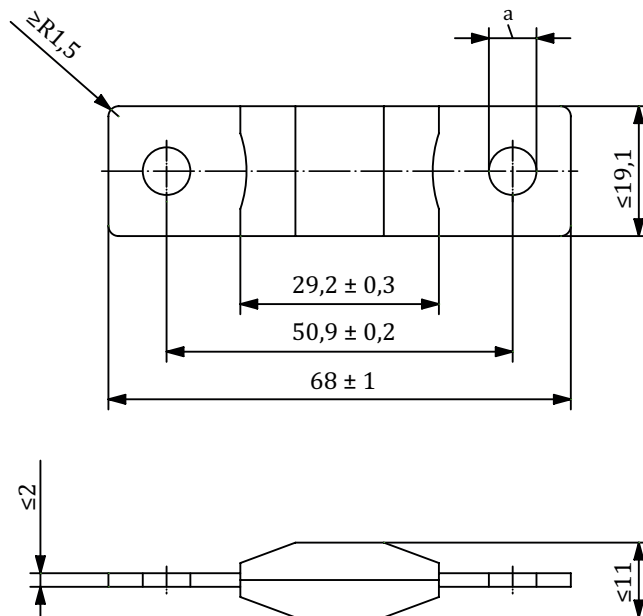

Key

a For bolt M8.

Figure 3 — Fuse-link type SF 51

6.2.2 Designation example

An example of the designation of a fuse-link type SF 51 for a rated current of 150 A is

Fuse ISO 8820-SF 51-150

7 Test fixture

7.1 General

This Clause establishes the overall dimensions, materials, finish, and coatings for the test fixture to perform electrical tests on fuse-links as specified herein.

7.2 Materials and dimensions

The test fixture shall conform to the material requirements and dimensions shown in [Table 7](#) to [Table 9](#) and [Figure 4](#) to [Figure 7](#). Alternative designs of test fixture are allowed in the case that the electrical and mechanical properties are equivalent.

Table 7 — Parts list and material specifications for M5 bolts

Reference no. in Figure 4	Description	Dimensions (see Figure)	Material specifications, finish, and coating	Quantity
1	Test fixture insulating body	7	Thermoset plastic	1
2	Bolt: ISO 4017-M5x20-8.8	—	Steel, gal. Zn	2

Table 7 (continued)

Reference no. in Figure 4	Description	Dimensions (see Figure)	Material specifications, finish, and coating	Quantity
3	Nut: ISO 4032-M5-8	—	Steel, gal. Zn	4
4	Washer ISO 7089-5-200 HV	—	Steel, gal. Zn	2

Dimensions in millimetres
Tolerances: in accordance with ISO 2768

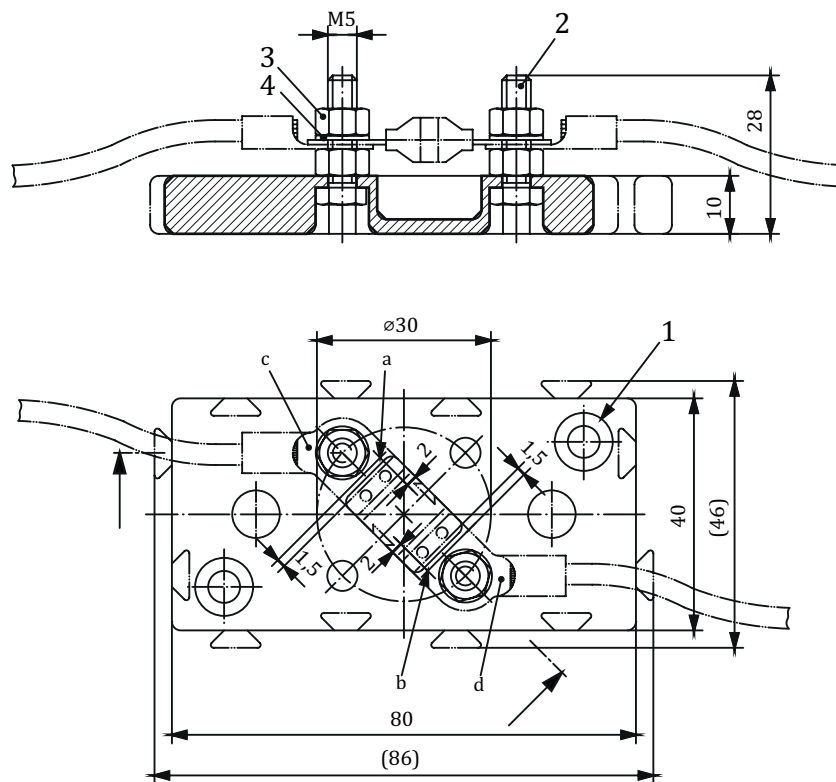

Key

- 1 Test fixture insulating body
- 2 Bolt: ISO 4017-M5x20-8,8
- 3 Nut: ISO 4032-M5-8
- 4 Washer: ISO 7089-5-200 HV

NOTE 1 Points a and b are measuring points for the voltage drop.

NOTE 2 Points a, c and b, d are the measuring points for connection resistance.

Figure 4 — Test fixture with M5 bolts for type SF 30 fuse-links

Table 8 — Parts list and material specifications with M6 bolts

Reference no. in Figure 5	Description	Dimensions (see Figure)	Material specifications, finish, and coating	Quantity
1	Test fixture insulating body	Z	Thermoset plastic	1
2	Bolt: ISO 4017-M6x20-8.8	—	Steel, gal. Zn	2
3	Nut: ISO 4032-M6-8	—	Steel, gal. Zn	4
4	Washer: ISO 7089-6-200HV	—	Steel, gal. Zn	2

Dimensions in millimetres
 Tolerances in accordance with ISO 2768

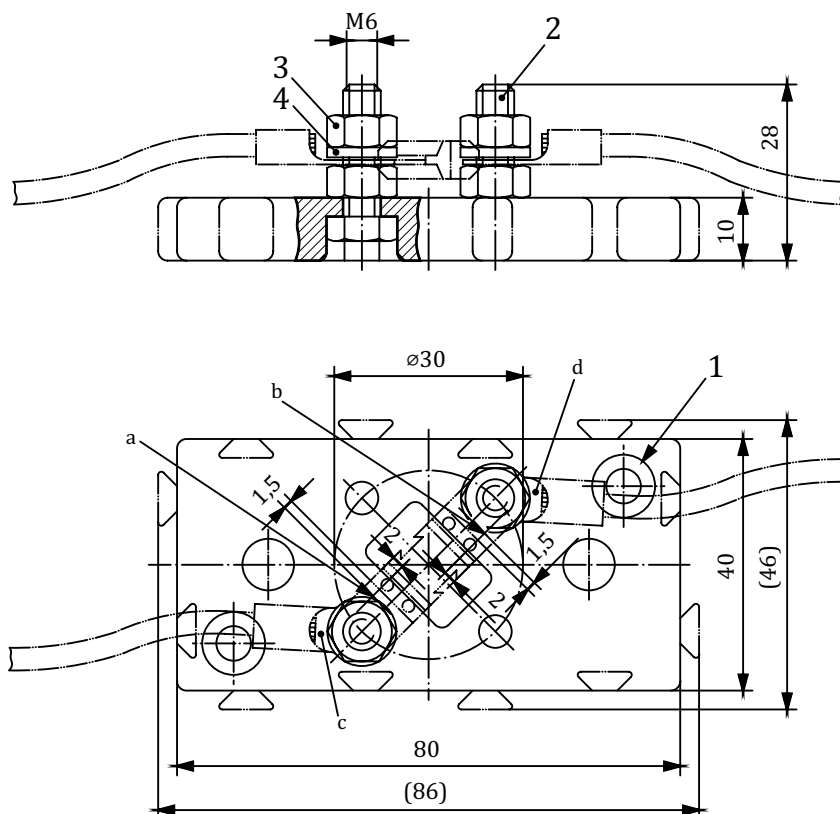

Key

- 1 Test fixture insulating body
- 2 Bolt: ISO 4017-M6x20-8,8
- 3 Nut: ISO 4032-M6-8
- 4 Washer: ISO 7089-5-200 HV

NOTE 1 Points a and b are measuring points for the voltage drop.

NOTE 2 Points a, c and b, d are the measuring points for connection resistance.

Figure 5 — Test fixture with M6 bolts for type SF 30 fuse-links

Table 9 — Parts list and material specifications with M8 bolts

Reference no. in Figure 6	Description	Dimensions (see Figure)	Material specifications, finish, and coating	Quantity
1	Test fixture insulating body	Z	Thermoset plastic	1
2	Bolt: ISO 4017-M8x30-8.8	—	Steel, gal. Zn	2
3	Nut: ISO 4032-M8-8	—	Steel, gal. Zn	4
4	Washer: ISO 7089-8-200HV	—	Steel, gal. Zn	2

Dimensions in millimetres
 Tolerances in accordance with ISO 2768

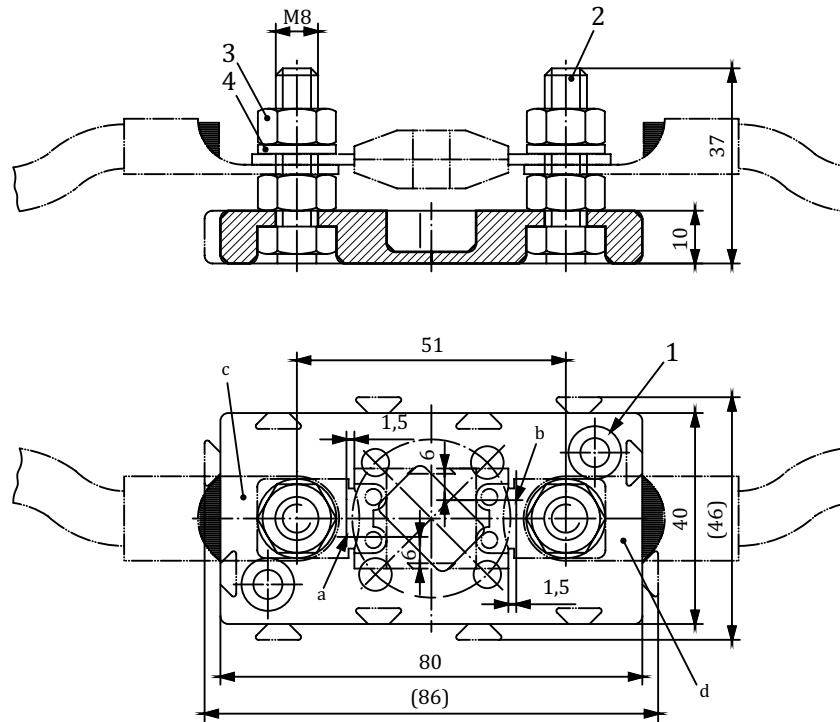

Key

- 1 Test fixture insulating body
- 2 Bolt: ISO 4017-M8x30-8,8
- 3 Nut: ISO 4032-M8-8
- 4 Washer: ISO 7089-5-200 HV

NOTE 1 Points a and b are measuring points for the voltage drop.

NOTE 2 Points a, c and b, d are the measuring points for connection resistance.

Figure 6 — Test fixture with M8 bolts for type SF 51 fuse-links

Bibliography

- [1] ISO 6722 (all parts), *Road vehicles — 60 V and 600 V single-core cables — Dimensions, test methods and requirements*

British Standards Institution (BSI)

BSI is the national body responsible for preparing British Standards and other standards-related publications, information and services.

BSI is incorporated by Royal Charter. British Standards and other standardization products are published by BSI Standards Limited.

About us

We bring together business, industry, government, consumers, innovators and others to shape their combined experience and expertise into standards-based solutions.

The knowledge embodied in our standards has been carefully assembled in a dependable format and refined through our open consultation process. Organizations of all sizes and across all sectors choose standards to help them achieve their goals.

Information on standards

We can provide you with the knowledge that your organization needs to succeed. Find out more about British Standards by visiting our website at bsigroup.com/standards or contacting our Customer Services team or Knowledge Centre.

Buying standards

You can buy and download PDF versions of BSI publications, including British and adopted European and international standards, through our website at bsigroup.com/shop, where hard copies can also be purchased.

If you need international and foreign standards from other Standards Development Organizations, hard copies can be ordered from our Customer Services team.

Subscriptions

Our range of subscription services are designed to make using standards easier for you. For further information on our subscription products go to bsigroup.com/subscriptions.

With **British Standards Online (BSOL)** you'll have instant access to over 55,000 British and adopted European and international standards from your desktop. It's available 24/7 and is refreshed daily so you'll always be up to date.

You can keep in touch with standards developments and receive substantial discounts on the purchase price of standards, both in single copy and subscription format, by becoming a **BSI Subscribing Member**.

PLUS is an updating service exclusive to BSI Subscribing Members. You will automatically receive the latest hard copy of your standards when they're revised or replaced.

To find out more about becoming a BSI Subscribing Member and the benefits of membership, please visit bsigroup.com/shop.

With a **Multi-User Network Licence (MUNL)** you are able to host standards publications on your intranet. Licences can cover as few or as many users as you wish. With updates supplied as soon as they're available, you can be sure your documentation is current. For further information, email bsmusales@bsigroup.com.

BSI Group Headquarters

389 Chiswick High Road London W4 4AL UK

Revisions

Our British Standards and other publications are updated by amendment or revision.

We continually improve the quality of our products and services to benefit your business. If you find an inaccuracy or ambiguity within a British Standard or other BSI publication please inform the Knowledge Centre.

Copyright

All the data, software and documentation set out in all British Standards and other BSI publications are the property of and copyrighted by BSI, or some person or entity that owns copyright in the information used (such as the international standardization bodies) and has formally licensed such information to BSI for commercial publication and use. Except as permitted under the Copyright, Designs and Patents Act 1988 no extract may be reproduced, stored in a retrieval system or transmitted in any form or by any means – electronic, photocopying, recording or otherwise – without prior written permission from BSI. Details and advice can be obtained from the Copyright & Licensing Department.

Useful Contacts:

Customer Services

Tel: +44 845 086 9001

Email (orders): orders@bsigroup.com

Email (enquiries): cservices@bsigroup.com

Subscriptions

Tel: +44 845 086 9001

Email: subscriptions@bsigroup.com

Knowledge Centre

Tel: +44 20 8996 7004

Email: knowledgecentre@bsigroup.com

Copyright & Licensing

Tel: +44 20 8996 7070

Email: copyright@bsigroup.com



...making excellence a habit.™