

Paper and board — Determination of roughness/smoothness (air leak methods) —

Part 3: Sheffield method

ICS 85.060

National foreword

This British Standard reproduces verbatim ISO 8791-3:2005 and implements it as the UK national standard.

The UK participation in its preparation was entrusted to Technical Committee PAI/11, Methods of test for paper, board and pulps, which has the responsibility to:

- aid enquirers to understand the text;
- present to the responsible international/European committee any enquiries on the interpretation, or proposals for change, and keep the UK interests informed;
- monitor related international and European developments and promulgate them in the UK.

A list of organizations represented on this committee can be obtained on request to its secretary.

Cross-references

The British Standards which implement international publications referred to in this document may be found in the *BSI Catalogue* under the section entitled “International Standards Correspondence Index”, or by using the “Search” facility of the *BSI Electronic Catalogue* or of British Standards Online.

This publication does not purport to include all the necessary provisions of a contract. Users are responsible for its correct application.

Compliance with a British Standard does not of itself confer immunity from legal obligations.

Summary of pages

This document comprises a front cover, an inside front cover, the ISO title page, pages ii to v, a blank page, pages 1 to 12, an inside back cover and a back cover.

The BSI copyright notice displayed in this document indicates when the document was last issued.

Amendments issued since publication

Amd. No.	Date	Comments

This British Standard was published under the authority of the Standards Policy and Strategy Committee on 16 March 2005

© BSI 16 March 2005

ISBN 0 580 45601 3

INTERNATIONAL
STANDARD

ISO
8791-3

Second edition
2005-02-15

**Paper and board — Determination of
roughness/smoothness (air leak
methods) —**

**Part 3:
Sheffield method**

*Papier et carton — Détermination de la rugosité/du lissé (méthodes du
débit d'air) —*

Partie 3: Méthode Sheffield



Reference number
ISO 8791-3:2005(E)

Contents

Page

Foreword.....	iv
Introduction	v
1 Scope.....	1
2 Normative references	1
3 Terms and definitions.....	1
4 Principle	2
5 Apparatus	2
6 Sampling	4
7 Conditioning	4
8 Preparation of test pieces	4
9 Calibration	4
9.1 Variable-area flow-measuring device.....	4
9.2 Electronic flow-measuring device.....	4
10 Procedure	4
10.1 Test atmosphere	4
10.2 Determination of roughness	5
11 Calculation and expression of results	5
12 Test report	5
Annex A (normative) Care and maintenance of test instrument with variable-area flowmeters	6
Annex B (normative) Calibration of flowmeters	7
Annex C (informative) Conversion table	11
Bibliography	12

Foreword

ISO (the International Organization for Standardization) is a worldwide federation of national standards bodies (ISO member bodies). The work of preparing International Standards is normally carried out through ISO technical committees. Each member body interested in a subject for which a technical committee has been established has the right to be represented on that committee. International organizations, governmental and non-governmental, in liaison with ISO, also take part in the work. ISO collaborates closely with the International Electrotechnical Commission (IEC) on all matters of electrotechnical standardization.

International Standards are drafted in accordance with the rules given in the ISO/IEC Directives, Part 2.

The main task of technical committees is to prepare International Standards. Draft International Standards adopted by the technical committees are circulated to the member bodies for voting. Publication as an International Standard requires approval by at least 75 % of the member bodies casting a vote.

Attention is drawn to the possibility that some of the elements of this document may be the subject of patent rights. ISO shall not be held responsible for identifying any or all such patent rights.

ISO 8791-3 was prepared by Technical Committee ISO/TC 6, *Paper, board and pulps*, Subcommittee SC 2, *Test methods and quality specifications for paper and board*.

This second edition cancels and replaces the first edition (ISO 8791-3:1990), which has been technically revised.

ISO 8791 consists of the following parts, under the general title *Paper and board — Determination of roughness/smoothness (air leak methods)*:

- *Part 1: General method*
- *Part 2: Bendtsen method*
- *Part 3: Sheffield method*
- *Part 4: Print-surf method*

Introduction

This part of ISO 8791 describes one of several methods of determining the roughness of paper and board by an air leak method. Since these methods are based on different geometrical designs and since they use different air pressures and subject the test piece to different clamping pressures, they give different numerical results. General requirements for such tests are described in ISO 8791-1^[1].

Paper and board — Determination of roughness/smoothness (air leak methods) —

Part 3: Sheffield method

1 Scope

This part of ISO 8791 specifies a method for the determination of the roughness of paper and board using the Sheffield apparatus.

The method is applicable to papers and boards which have Sheffield roughness values between 10 and about 3 000 ml/min. It is not suitable for soft papers which allow the lands of the test head to indent the surface, or for high air-permeance papers which allow a significant flow of air through the sheet, or for papers which will not lie flat during the test.

2 Normative references

The following referenced documents are indispensable for the application of this document. For dated references, only the edition cited applies. For undated references, the latest edition of the referenced document (including any amendments) applies.

ISO 186, *Paper and board — Sampling to determine average quality*

ISO 187, *Paper, board and pulps — Standard atmosphere for conditioning and testing and procedure for monitoring the atmosphere and conditioning of samples*

3 Terms and definitions

For the purposes of this document, the following terms and definitions apply.

3.1

Sheffield roughness

rate at which air flows between flat circular lands and the surface of a sheet of paper or board under specified conditions

NOTE 1 The roughness is expressed in millilitres per minute.

NOTE 2 The Sheffield unit is not defined, since it has been found that the scale units (Sheffield units) on different instruments can correspond to different air flows, and there is no precise physical definition. This part of ISO 8791 requires that the flowmeters be calibrated to give a flow rate in millilitres per minute.

4 Principle

A test piece is clamped between a flat plate and two flat concentric annular lands. Air is supplied at a specified pressure to the space between the two lands and the rate of air flow between the lands and the test piece is measured. The air flow rate is a measure of the roughness of the test piece.

5 Apparatus

The apparatus, an example of which is shown in Figure 1, shall consist of an air supply, an air pressure control and air flow measuring device, a test assembly which houses a flat plate, a measuring head fitted with test lands, and a mechanical device for bringing the lands into contact with the flat plate under a defined load.

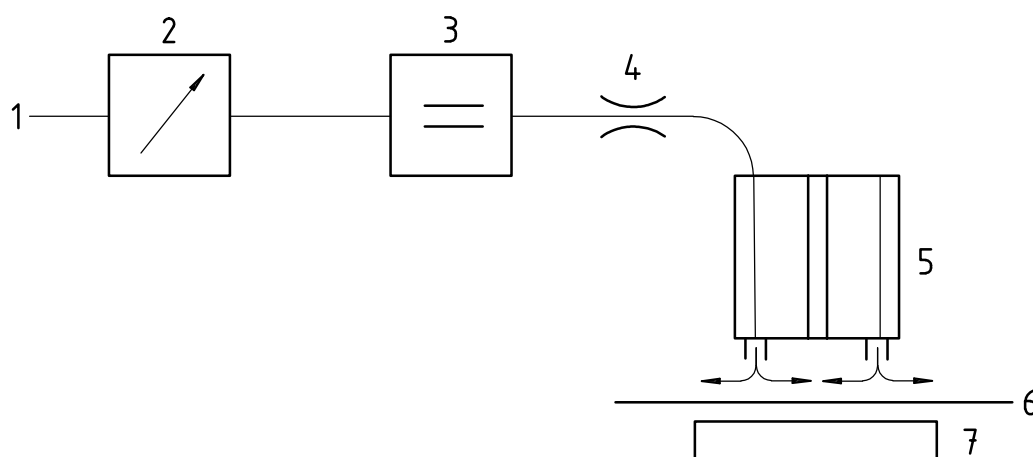

Key

- 1 air supply
- 2 pressure regulator
- 3 flow-measuring device
- 4 flow impedance
- 5 test assembly
- 6 test piece
- 7 flat plate

Figure 1 — Example of Sheffield apparatus

5.1 Air supply, free of water, oil and other contaminants, at a pressure of 420 kPa to 950 kPa. A small compressor using laboratory air is preferred to external compressed air.

5.2 Pressure regulating device, consisting of a primary regulator to reduce the pressure to between 205 kPa and 210 kPa and a further regulator to adjust the pressure at the measuring head to 10,3 kPa (variable-area flowmeters) or 9,85 kPa (electronic flowmeters).

5.3 Pressure manometer, with a range from 0 to 20 kPa to enable the air pressure at the measuring head to be set to the specified pressure within 2 % of the nominal value.

5.4 Flow-measuring device, of either a variable-area or an electronic type. The air flow shall be measurable to an accuracy of ± 5 % of the measured value.

5.4.1 Variable-area flow-measuring device, consisting of three variable-area flowmeters each having a tapered glass column containing a metering float suspended by the air flow in the column (see [3] in the Bibliography). The three columns shall be chosen such that they enable measurement to be made on a continuous scale of flow rate from 10 ml/min to 3 000 ml/min, with some overlap of scales between columns.

Each column shall be provided with a means of adjusting the flow rate (float-position knob) and a means of span calibration (calibrating knob). This type of instrument shall operate at a supply pressure of 10,3 kPa.

At air flow rates greater than 1 200 ml/min, the pressure drop in the Sheffield system is substantial and, to ensure reproducibility of results, it is necessary that the tubing used to connect the flowmeter to the measuring head be carefully controlled with a length of $1,50 \text{ m} \pm 0,01 \text{ m}$ and an internal diameter of $6,25 \text{ mm} \pm 0,25 \text{ mm}$. For the same reason, openings in valves and other fittings on the instrument must not be changed from those provided by the instrument manufacturer.

5.4.2 Electronic flow-measuring device, for measuring the air flow to the test assembly (measuring head). The inlet pressure to the measurement device shall be controlled at 9,85 kPa.

NOTE The 9,85 kPa pressure is the typical pressure measured downstream of variable-area flow tubes that have been calibrated using the zero and span adjustment air bleeds to atmosphere.

5.5 Test assembly

5.5.1 The measuring head, together with a dead weight, shall have a mass of $1\,640 \text{ g} \pm 2 \text{ g}$, shall have two concentric annular lands made of, or coated with, a corrosion-resistant material and be designed to contact the test piece. The annular lands shall have a total area of $97 \text{ mm}^2 \pm 3 \text{ mm}^2$; each land shall have a width of $0,380 \pm 0,010 \text{ mm}$. The outer diameters of the outer and inner lands shall be $47,70 \text{ mm} \pm 0,03 \text{ mm}$ and $34,37 \text{ mm} \pm 0,03 \text{ mm}$, respectively.

The test assembly, an example of which is shown in Figure 2, shall include a detachable measuring head mounted so that it can be brought into contact with a test piece placed on an optically flat plate.

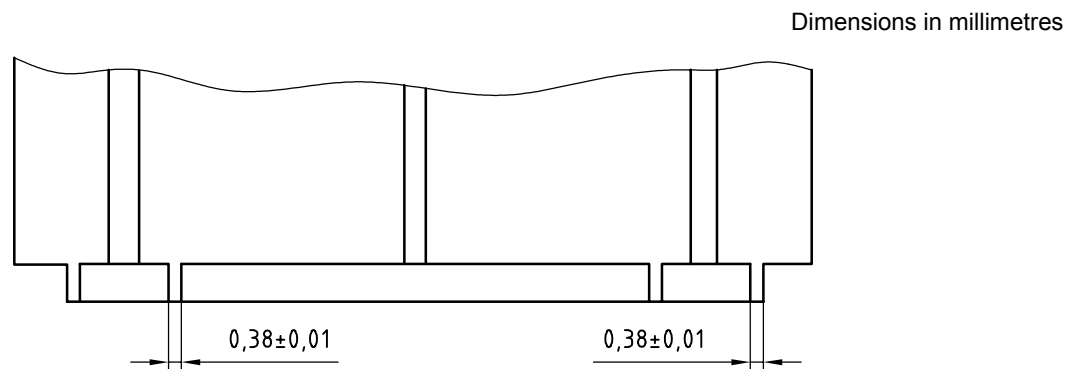

Figure 2 — Example of test assembly

The measuring head shall be connected to the air supply with an airtight seal and the air shall be fed into the gap between the two measuring lands through a narrow hole bored through the material of the measuring head. This can act as impedance in the measurement air line, see Figure 1 (4). The central space inside the inner land shall be vented to the atmosphere.

The test assembly shall have a suitable coupling through which the chosen flowmeter is connected to the tube leading to the measuring head. The tube connecting the measuring head to the instrument, and the tube connectors, have internal diameters that provide resistance to the air flow. Alteration of these components from those provided by the manufacturer may change the calibration and operation of the instrument.

5.5.2 The flat plate is usually glass and shall be free from surface flaws. The measuring lands shall be machined and the supporting plate shall be sufficiently flat so that, when the measuring lands are in contact with the plate in the absence of any test piece, the air flow rate does not exceed 10 ml/min.

5.6 Calibration plate device, if the instrument employs an electronic flow-measuring device, the plate device will enable the test assembly to be connected to an external calibration system (see Clause 9 and Annex B).

NOTE 1 Although this calibration plate is necessary only with electronic devices, it can also be used in instruments incorporating a variable-area flow-measuring device.

NOTE 2 Sheffield reference surface masters are available to check orifices for contamination and measuring heads for wear or damage, but these are not specified by this part of ISO 8791.

6 Sampling

Sampling is not included in this part of ISO 8791. If the mean quality of a lot is to be determined, sampling shall be in accordance with ISO 186. If the tests are made on another type of sample, make sure that the test pieces taken are representative of the sample received.

7 Conditioning

Condition the samples in accordance with ISO 187.

8 Preparation of test pieces

Cut at least 10 test pieces, each at least 100 mm × 100 mm for each surface to be tested, and identify the two sides (e.g. side one and side two). The test pieces shall be free from watermarks, creases, wrinkles, rubber marks, and other defects. Do not handle that part of the test piece which will become the test area.

9 Calibration

9.1 Variable-area flow-measuring device

Calibrate the instrument against an external flow-measuring device as described in B.1, and prepare a calibration graph or chart as described in B.2.

Calibrate the instrument sufficiently frequently to ensure that the reading does not deviate at any time by more than $\pm 5\%$ from the true value.

9.2 Electronic flow-measuring device

Carry out the internal adjustment of the flowmeter according to the manufacturer's instructions. Check the calibration of the instrument against an external flow-measuring device as described in B.1.

10 Procedure

10.1 Test atmosphere

Carry out all testing under the same atmospheric conditions as those used to condition the sample in accordance with ISO 187.

10.2 Determination of roughness

10.2.1 Ensure that the instrument is level on a surface free from vibrations. Check that the air pressure to the measuring head is correct (see 5.4.1 or 5.4.2). Check that the reading obtained against the glass plate (see 5.5.2) with no test piece present is less than 10 ml/min.

10.2.2 Place a test piece in the measuring gap and measure the roughness in accordance with the manufacturer's instructions. Record the result.

All papers are hygroscopic to some degree, and readings should be taken at the initial stabilization point to avoid any possible effect of the incoming air adding moisture to, or extracting moisture from, the test piece.

10.2.3 Repeat the measurement on the remaining test pieces.

11 Calculation and expression of results

11.1 If the instrument provides readings in "Sheffield units", convert each reading to an air-flow rate, in millilitres per minute, using the calibration chart or graph prepared as described in B.2.

11.2 Calculate the roughness, expressed as the mean flow rate to three significant figures, for each side to be tested.

11.3 Calculate the standard deviation or coefficient of variation of the flow rate, to two significant figures, for each side to be tested.

12 Test report

The test report shall include the following:

- a) reference to this part of ISO 8791;
- b) date and place of testing;
- c) all information necessary for complete identification of the sample;
- d) the type of instrument used and, if appropriate, the flowmeter range used;
- e) the arithmetic mean result (11.2);
- f) the standard deviation or coefficient of variation (see 11.3);
- g) any deviation from the procedure specified in this part of ISO 8791 which may have affected the result.

Annex A (normative)

Care and maintenance of test instrument with variable-area flowmeters

Weekly, or more often if required, check the cleanliness of the working orifices by testing against a spare manifold.

Check each orifice of the calibration orifice manifold for contamination. If necessary, clean with a suitable solvent, for example, petroleum ether (boiling point 60 °C to 100 °C).

If the floats tend to stick in the air flowmeter columns, this may be due to dirt or static electrical charges. Clean as indicated in the instrument manual.

Renew the rubber gaskets in the hose couplings at least once a year.

Annex B (normative)

Calibration of flowmeters

B.1 Calibration of flowmeters

B.1.1 General

The flowmeters may be calibrated with any instrument and procedure which provides a calibration accuracy to within 1,2 %.

One procedure for calibrating variable-area flowmeters uses a soap-bubble meter, Figure B.1, is described in ISO 11605^[2]. The method can also be used to calibrate electronic flow-measuring devices, provided a suitable attachment is available.

The principle of the method is that the movement of a soap bubble introduced into an air flow from the flow-measuring device being tested is timed between two marks in a volumeter, representing an accurately known volume, and the actual air-flow rate is calculated. This is repeated at other air flow rates until the whole flowmeter range of the instrument has been covered.

NOTE This method of calibration gives satisfactory accuracy from test atmospheric conditions which do not deviate appreciably from 101,3 kPa and 23 °C. For this reason, it is desirable, if possible, to choose a day for calibration when the meteorological conditions are favourable.

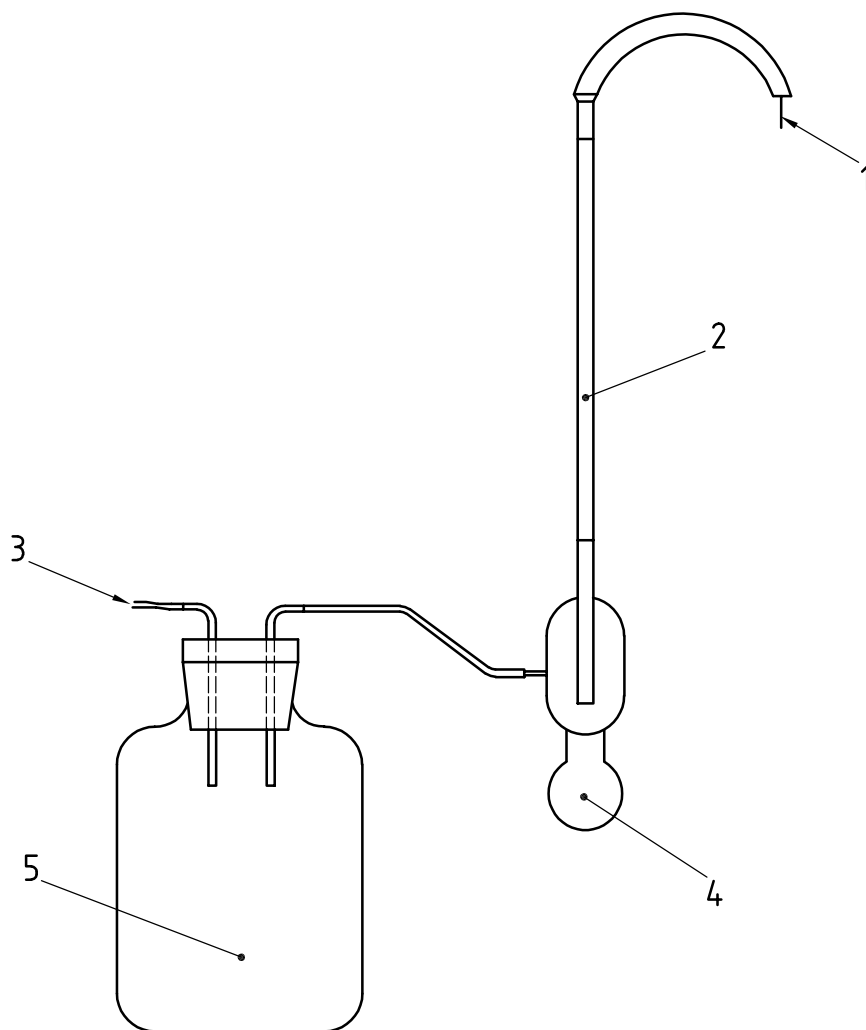
**Key**

- 1 needle valve
- 2 volumeter
- 3 connection point
- 4 rubber bulb
- 5 glass flask, of capacity 1 litre

Figure B.1 — Soap-bubble meter**B.1.2 Apparatus and materials****B.1.2.1 Soap-bubble meter consisting of the following:**

- glass flask or bottle, of capacity 1 litre;
- volumetric tube, with graduation marks indicating 50 ml, 1 000 ml and 2 000 ml; the different ranges may be achieved with replaceable volumeters (suitable designs are described in [4]);
- needle valve;
- glass and rubber tubing, of as large an internal diameter and as short a length as practicable to minimize pressure drop.

B.1.2.2 Stopwatch, capable of being read to 0,1 s.

B.1.2.3 Soap solution, 3 % to 5 % liquid detergent in distilled water.

B.1.2.4 Barometer, or other means of ascertaining the actual atmospheric pressure.

NOTE It may be sufficient to contact a local meteorological station to obtain information about the atmospheric pressure.

B.1.3 Procedure

Make sure that the instrument is level on a surface free from vibrations. Make sure that the internal adjustment of the flowmeter has been carried out according to the manufacturer's instructions.

B.1.3.1 Prior to performing the following calibration procedure, the variable-area flow tubes and the air leak adjustment valves on the older style instruments shall first be calibrated to Sheffield Units using calibration orifices provided by the manufacturer. In operation, the instrument shall always be checked against the manufacturer's calibration orifices, prior to using the flow tube, to ml/min calibration graph or chart.

To calibrate a variable-area flow-measuring device, disconnect the test assembly from the downstream end of the rubber or plastic tubing and connect the soap-bubble meter in its place. Set the valves to deliver air through the flowmeter to be calibrated and then through the soap-bubble meter. Adjust the needle valve to give a conveniently measurable air flow and ensure that the flow rate remains constant. Rapidly squeeze the rubber bulb at the bottom of the volumeter so that a soap bubble enters the volumeter tube. The volumeter range should be chosen so that the time taken for the bubble to pass from the first to the second graduation is longer than 30 s.

Record the reading x on the flowmeter scale and record the time, t , in seconds for the soap bubble to pass through the volume V .

Repeat the procedure at about six different air flow rates distributed over the upper 80 % of the flowmeter measurement range.

Record the atmospheric pressure p .

NOTE A better calibration may be achieved by leaving the measuring head in position and using a calibration plate device such as that used with an electronic flow-measuring instrument, since this set-up includes the restriction within the measuring head.

B.1.3.2 To calibrate an electronic flow-measuring device, connect the soap-bubble meter to the calibration plate device (5.6) placed beneath the measuring head. Set the valves to deliver air through the flowmeter to be calibrated and then through the soap-bubble meter. Adjust the needle valve to give a conveniently measurable air flow and ensure that the flow rate remains constant. Rapidly squeeze the rubber bulb at the bottom of the volumeter so that a soap bubble enters the volumeter tube. The volumeter range should be chosen so that the time taken for the bubble to pass from the first to the second graduation is longer than 30 s.

Record the reading x on the flowmeter scale and record the time, t , in seconds, for the soap bubble to pass through the volume V .

Repeat the procedure at about six different air flow rates distributed over the upper 80 % of the flowmeter measurement range.

Record the atmospheric pressure p .

B.1.4 Calculation

For each determination, calculate the flow rate q , in millilitres per minute, as

$$q = \frac{60 \times V}{t}$$

where

V is the known volume, in millilitres, between the two graduations on the volumeter;

t is the time, in seconds, taken for the soap bubble to go from the first to the second graduation.

If the actual atmospheric pressure differs by more than 5 % from the normal atmospheric pressure of 101,3 kPa, calculate the corrected flow rate q_o as follows:

$$q_o = q \frac{(p + 10,3)}{111,6} = 0,538(p + 10,3) \frac{V}{t}$$

where p is the actual atmospheric pressure.

NOTE 1 The pressure of 111,6 kPa is the sum of the normal atmospheric pressure, 101,3 kPa, and the nominal operating pressure, 10,3 kPa, at 23 °C.

NOTE 2 The air passing through the apparatus may pick up moisture from the walls of the soap-bubble meter and the air flow may thus be overestimated. The error is, however, appreciably less than the inherent errors associated with the Sheffield instrument and it may therefore be ignored.

B.2 Construction of a calibration graph

Construct a graph by plotting the scale reading x against the calculated air flow q or q_o for each flowmeter. The graph should be a straight line which can be represented by an equation of the form.

$$q = A + Bx$$

where

A and B are constants;

x is the scale reading, in Sheffield units.

This graph or equation can be used for conversion of the data to air flow rates, in millimetres per minute.

Annex C (informative)

Conversion table

**Table C.1 — Conversion of the traditional Sheffield units (SU) to SI units
(derived from a survey of 12 instruments) (see [5] in the Bibliography)**

Tube No. 3 SU	Air flow rate ml/min ^a	Tube No. 2 SU	Air flow rate ml/min ^a	Tube No. 1 SU	Air flow rate ml/min ^a
0	0	50	303	160	1 334
5	35	60	404	180	1 501
10	70	70	495	200	1 668
15	104	80	585	220	1 835
20	139	90	676	240	2 002
25	174	100	767	260	2 170
30	209	110	858	280	2 337
35	244	120	949	300	2 504
40	278	130	1 039	320	2 671
45	313	140	1 130	340	2 838
50	343	150	1 221	360	3 006
55	383	160	1 312	380	3 137
60	412	170	1 403	400	3 340
		180	1 493		
		190	1 584		
Sheffield tube No.		Recommended range Sheffield units, SU		Conversion to SI units, ml/min^a	
3		0 to 56		ml/min = 6,96 SU	
2		56 to 170		ml/min = 9,08 (SU) – 141	
1		170 to 400		ml/min = 8,36 (SU) + 4	
^a Air flow rate is measured in millilitres per minute (ml/min), referenced to 21 °C and 101,3 kPa.					

Bibliography

- [1] ISO 8791-1:1986, *Paper and board — Determination of roughness/smoothness (air leak methods) — Part 1: General method*
- [2] ISO 11605:1995, *Paper and board — Calibration of variable-area flowmeters*
- [3] LASHOF, T.W., MANDEL, J. and WORTHINGTON, W. Tappi 39: pp. 532-543 (1956)¹⁾
- [4] GOODERHAM, J.W. *J. Soc. Chem. Ind.* 63:351 (1944)
- [5] TAPPI test method T 538 om-01, *Roughness of paper and paperboard (Sheffield method)*, Tappi Press, Atlanta, GA, USA

1) This publication includes references to a device for overcoming the problem of the No. 3 tube.

BSI — British Standards Institution

BSI is the independent national body responsible for preparing British Standards. It presents the UK view on standards in Europe and at the international level. It is incorporated by Royal Charter.

Revisions

British Standards are updated by amendment or revision. Users of British Standards should make sure that they possess the latest amendments or editions.

It is the constant aim of BSI to improve the quality of our products and services. We would be grateful if anyone finding an inaccuracy or ambiguity while using this British Standard would inform the Secretary of the technical committee responsible, the identity of which can be found on the inside front cover.
Tel: +44 (0)20 8996 9000. Fax: +44 (0)20 8996 7400.

BSI offers members an individual updating service called PLUS which ensures that subscribers automatically receive the latest editions of standards.

Buying standards

Orders for all BSI, international and foreign standards publications should be addressed to Customer Services. Tel: +44 (0)20 8996 9001.
Fax: +44 (0)20 8996 7001. Email: orders@bsi-global.com. Standards are also available from the BSI website at <http://www.bsi-global.com>.

In response to orders for international standards, it is BSI policy to supply the BSI implementation of those that have been published as British Standards, unless otherwise requested.

Information on standards

BSI provides a wide range of information on national, European and international standards through its Library and its Technical Help to Exporters Service. Various BSI electronic information services are also available which give details on all its products and services. Contact the Information Centre.
Tel: +44 (0)20 8996 7111. Fax: +44 (0)20 8996 7048. Email: info@bsi-global.com.

Subscribing members of BSI are kept up to date with standards developments and receive substantial discounts on the purchase price of standards. For details of these and other benefits contact Membership Administration.
Tel: +44 (0)20 8996 7002. Fax: +44 (0)20 8996 7001.
Email: membership@bsi-global.com.

Information regarding online access to British Standards via British Standards Online can be found at <http://www.bsi-global.com/bsonline>.

Further information about BSI is available on the BSI website at <http://www.bsi-global.com>.

Copyright

Copyright subsists in all BSI publications. BSI also holds the copyright, in the UK, of the publications of the international standardization bodies. Except as permitted under the Copyright, Designs and Patents Act 1988 no extract may be reproduced, stored in a retrieval system or transmitted in any form or by any means – electronic, photocopying, recording or otherwise – without prior written permission from BSI.

This does not preclude the free use, in the course of implementing the standard, of necessary details such as symbols, and size, type or grade designations. If these details are to be used for any other purpose than implementation then the prior written permission of BSI must be obtained.

Details and advice can be obtained from the Copyright & Licensing Manager.
Tel: +44 (0)20 8996 7070. Fax: +44 (0)20 8996 7553.
Email: copyright@bsi-global.com.