

BS ISO 8600-2:2015



BSI Standards Publication

Endoscopes - Medical endoscopes and endotherapy devices

Part 2: Particular requirements for rigid
bronchoscopes

bsi.

...making excellence a habit.™

National foreword

This British Standard is the UK implementation of ISO 8600-2:2015. It supersedes BS ISO 8600-2:2002 which is withdrawn.

The UK participation in its preparation was entrusted to Technical Committee CPW/172, Optics and Photonics.

A list of organizations represented on this committee can be obtained on request to its secretary.

This publication does not purport to include all the necessary provisions of a contract. Users are responsible for its correct application.

© The British Standards Institution 2015. Published by BSI Standards Limited 2015

ISBN 978 0 580 85854 3

ICS 11.040.55

Compliance with a British Standard cannot confer immunity from legal obligations.

This British Standard was published under the authority of the Standards Policy and Strategy Committee on 30 April 2015.

Amendments issued since publication

Date	Text affected
------	---------------

INTERNATIONAL
STANDARD

BS ISO 8600-2:2015

ISO
8600-2

Second edition
2015-04-01

**Endoscopes - Medical endoscopes and
endotherapy devices —**

Part 2:
**Particular requirements for rigid
bronchoscopes**

*Endoscopes - Endoscopes médicaux et dispositifs d'endothérapie —
Partie 2: Exigences particulières pour bronchoscopes rigides*



Reference number
ISO 8600-2:2015(E)

© ISO 2015



COPYRIGHT PROTECTED DOCUMENT

© ISO 2015

All rights reserved. Unless otherwise specified, no part of this publication may be reproduced or utilized otherwise in any form or by any means, electronic or mechanical, including photocopying, or posting on the internet or an intranet, without prior written permission. Permission can be requested from either ISO at the address below or ISO's member body in the country of the requester.

ISO copyright office
Case postale 56 • CH-1211 Geneva 20
Tel. + 41 22 749 01 11
Fax + 41 22 749 09 47
E-mail copyright@iso.org
Web www.iso.org

Published in Switzerland

Contents

Page

Foreword	iv
Introduction	v
1 Scope	1
2 Normative references	1
3 Terms and definitions	1
4 Requirements	2
4.1 General.....	2
4.2 Dimensions.....	2
4.2.1 Working length.....	2
4.2.2 Total length.....	2
4.2.3 Maximum insertion portion width.....	2
4.3 Rigid ventilation bronchoscopes.....	3
4.4 Rigid jet-ventilation bronchoscopes.....	3
4.5 Side apertures.....	3
5 Testing	7
5.1 General.....	7
5.2 Test method for pressure drop.....	7
5.2.1 Purpose.....	7
5.2.2 Apparatus.....	7
5.2.3 Procedure.....	8
5.2.4 Expression of results.....	8
5.3 Test method for security of attachment of a jet-injector to the rigid bronchoscope.....	9
5.3.1 Purpose.....	9
5.3.2 Apparatus.....	9
5.3.3 Procedure.....	9
5.3.4 Expression of results.....	10
5.4 Test method for container pressure with an open-ended jet-injector bronchoscope.....	10
5.4.1 Purpose.....	10
5.4.2 Apparatus.....	10
5.4.3 Procedure.....	10
5.4.4 Expression of results.....	10
5.5 Test method for minimum instrument channel width.....	11
5.5.1 Purpose.....	11
5.5.2 Apparatus.....	11
5.5.3 Procedure.....	11
5.5.4 Expression of results.....	12
6 Marking	12
7 Instruction manual	12
8 Packaging	12
Annex A (informative) Rationale	13
Bibliography	15

Foreword

ISO (the International Organization for Standardization) is a worldwide federation of national standards bodies (ISO member bodies). The work of preparing International Standards is normally carried out through ISO technical committees. Each member body interested in a subject for which a technical committee has been established has the right to be represented on that committee. International organizations, governmental and non-governmental, in liaison with ISO, also take part in the work. ISO collaborates closely with the International Electrotechnical Commission (IEC) on all matters of electrotechnical standardization.

The procedures used to develop this document and those intended for its further maintenance are described in the ISO/IEC Directives, Part 1. In particular the different approval criteria needed for the different types of ISO documents should be noted. This document was drafted in accordance with the editorial rules of the ISO/IEC Directives, Part 2 (see www.iso.org/directives).

Attention is drawn to the possibility that some of the elements of this document may be the subject of patent rights. ISO shall not be held responsible for identifying any or all such patent rights. Details of any patent rights identified during the development of the document will be in the Introduction and/or on the ISO list of patent declarations received (see www.iso.org/patents).

Any trade name used in this document is information given for the convenience of users and does not constitute an endorsement.

For an explanation on the meaning of ISO specific terms and expressions related to conformity assessment, as well as information about ISO's adherence to the WTO principles in the Technical Barriers to Trade (TBT), see the following URL: [Foreword — Supplementary information](#).

The committee responsible for this document is ISO/TC 172, *Optics and photonics*, Subcommittee SC 5, *Microscopes and endoscopes*.

This second edition cancels and replaces the first edition (ISO 8600-2:2002), of which it constitutes a minor revision.

ISO 8600 consists of the following parts, under the general title *Endoscopes — Medical endoscopes and endoscopic accessories*:

- *Part 1: General requirements*
- *Part 2: Particular requirements for rigid bronchoscopes*
- *Part 3: Determination of field of view and direction of view of endoscopes with optics*
- *Part 4: Determination of maximum width of insertion portion*
- *Part 5: Determination of optical resolution of rigid endoscopes with optics*
- *Part 6: Vocabulary*
- *Part 7: Basic requirements for medical endoscopes of water-resistant type*

Introduction

Rigid bronchoscopes need to serve three simultaneous functions during endoscopic procedures

- as an endoscope with distal illumination to allow visualization of the larynx, trachea and bronchi, and views into the bronchial trees,
- as a sheath for a flexible or rigid endoscope, aspirator (suction channel), biopsy forceps, scissors, etc., and
- as a gas passage (airway) for the terminal part of an anaesthesia ventilation system or the upper respiratory tract.

Rigid bronchoscopes, therefore, are to have sufficiently large channels with low gas-flow resistance and an adequate gas supply from the breathing system of an anaesthetic and/or breathing machine, or from compressed air/oxygen gas sources. Particular attention therefore is paid to the life-sustaining ventilatory aspects of this part of ISO 8600.

Ideally, all rigid bronchoscopes are to be usable to ventilate the patient whenever clinically necessary either under general anaesthesia or not, by means of a ventilation connector and an end-cap for assisted/controlled ventilation or by means of a jet-injector for intermittent jet ventilation. In addition to the general features of rigid bronchoscopes, the ventilatory aspects of both rigid ventilation bronchoscopes and rigid jet-ventilation bronchoscopes are especially included in this part of ISO 8600.

Test methods other than those specified in this part of ISO 8600, but of equal or greater accuracy, may be used to verify compliance with the given requirements. However, in the event of a dispute, the methods specified in this part of ISO 8600 are to be used as the reference methods.

A rationale for the most important requirements is given in [Annex A](#). It is considered that knowledge of the reasons for the requirements will not only facilitate the proper application of this part of ISO 8600, but will expedite any subsequent revision.

Endoscopes - Medical endoscopes and endotherapy devices —

Part 2: Particular requirements for rigid bronchoscopes

1 Scope

This part of ISO 8600 specifies requirements for rigid bronchoscopes and their endoscopic accessories used in the practice of anaesthesia and medical endoscopy.

2 Normative references

The following documents, in whole or in part, are normatively referenced in this document and are indispensable for its application. For dated references, only the edition cited applies. For undated references, the latest edition of the referenced document (including any amendments) applies.

ISO 5356-1:1996, *Anaesthetic and respiratory equipment — Conical connectors — Part 1: Cones and sockets*

ISO 8600-1:2013, *Endoscopes — Medical endoscopes and endotherapy devices — Part 1: General requirements*

3 Terms and definitions

For the purposes of this document, the terms and definitions given in ISO 8600-1 and the following apply.

3.1

rigid bronchoscope

open straight tube-type rigid endoscope fitted with a means of illumination through the distal end and intended to be introduced into the tracheobronchial airway, having an internal lumen sufficiently large to permit free respiration of the patient

3.2

rigid ventilation bronchoscope

rigid bronchoscope, fitted with a removable end-cap at the proximal end of the open straight tube and having an internal lumen sufficiently large to permit ventilation of the patient through an integral ventilation connector

3.3

rigid jet ventilation bronchoscope

rigid bronchoscope provided with a jet-injector

Note 1 to entry: Rigid bronchoscopes provided with only a gas nipple should not be included within the category of jet-ventilation bronchoscopes, because the Venturi principle does not necessarily function sufficiently to ventilate the patient.

3.4

ventilation connector

breathing system connector

integral part of a rigid-ventilation bronchoscope that permits connection to a breathing system of an anaesthetic or breathing machine

3.5

end-cap

removable fitting at the proximal end of a rigid-ventilation bronchoscope to seal its lumen

3.6

jet-injector

narrow-lumen tubular device utilizing compressed gases (often using the Venturi principle) to provide intermittent positive gas pressure to the lungs of a patient

Note 1 to entry: Gases selected may include air, oxygen and/or other gases.

3.7

jet ventilation

artificial inflation of the lungs by intermittent release of compressed gases by means of a jet-injector within or towards the trachea and bronchi of a patient

3.8

maximum insertion portion width

maximum external width of an endoscope or endotherapy device throughout the length of the insertion portion to be inserted

Note 1 to entry: The maximum width of any expandable or transformable portion of the insertion portion is not considered as a maximum insertion portion width, such as balloons, controllable parts, jaws and the like having variable insertion portion widths.

Note 2 to entry: See also ISO 8600-6.

[SOURCE: ISO 8600-1:2013, definition 3.10]

3.9

total length

distance between the proximal and distal ends of a rigid bronchoscope

4 Requirements

4.1 General

Rigid bronchoscopes shall comply with the requirements specified in ISO 8600-1. In addition, rigid bronchoscopes shall also comply with the requirements specified in [4.2](#) and [4.5](#); rigid-ventilation bronchoscopes shall also comply with the requirements specified in [4.3](#) and rigid jet-ventilation bronchoscopes shall also comply with the requirements specified in [4.4](#).

4.2 Dimensions

4.2.1 Working length

The actual working length of a rigid bronchoscope shall be at least as long as, and not more than, 10 mm longer than the working length stated in the instructions for use provided by the manufacturer.

4.2.2 Total length

The total length shall be in the range ± 10 mm to the length stated in instructions for use.

4.2.3 Maximum insertion portion width

The maximum insertion portion width shall be in the range ± 1 mm stated in the instructions for use provided by the manufacturer.

4.3 Rigid ventilation bronchoscopes

4.3.1 A rigid ventilation bronchoscope shall be provided with an integral ventilation connector and an end-cap at its proximal end. Provision shall be made for insertion of endoscopes and endoscopic accessories through the end-cap. The end-cap shall not accidentally detach at an airway pressure of less than 4,0 kPa (40 cmH₂O).

An end-cap may incorporate a transparent window and/or may permit the insertion of an endoscope or endoscopic accessory through the opening or an airtight gasket. Removal or opening of the end-cap for accessory insertion may be achieved by the detachment, rotation or sliding of the end-cap.

4.3.2 A rigid ventilation bronchoscope shall be provided, in a side-arm, either with an integral ventilation connector or shall be provided with a detachable adapter which shall meet the requirements for 15 mm male conical connectors specified in ISO 5356-1 (see [Figure 1](#)). This shall not be a connector in which the internal lumen has been reduced. The ventilation connector, when fitted to the rigid ventilation bronchoscope, shall permit to-and-fro ventilation of the patient.

Adding a smaller connector to a 15 mm adapter creates a low dead-space connector. Users should be aware of the danger of using two connected low dead-space connectors, which may cause excessive flow resistance.

A ventilation connector may be located at either side of the rigid bronchoscope (see [Figure 1](#)) and may swivel around the shaft of the rigid bronchoscope.

4.4 Rigid jet-ventilation bronchoscopes

4.4.1 Rigid jet-ventilation bronchoscopes shall be provided with a jet-injector intended for jet ventilation.

Jet ventilation through a rigid bronchoscope is usually possible without a separate jet-injector port. [Figure 2](#) gives examples of different bronchoscopes where jet injection is possible.

4.4.2 When tested in accordance with [5.3](#), a jet-injector supplied with a bronchoscope shall withstand a minimum force of 20 N without becoming detached.

4.4.3 When tested in accordance with [5.4](#), the container pressure generated by a rigid jet-ventilation bronchoscope with any jet-injector provided by the manufacturer shall not exceed 6,0 kPa (60 cmH₂O).

If the bronchoscopist uses jet-injectors other than those provided by the manufacturer, he/she is responsible for its function and performance.

The ventilation pressure developed by any jet-injector depends on the characteristics of the bronchoscope with which it is used or tested. Users should be aware that ventilation pressure can be greatly increased by insertion of any obstruction, e.g. an aspirator or forceps, into the lumen of the rigid bronchoscope.

4.5 Side apertures

4.5.1 Side apertures, if provided, shall be located on the rigid bronchoscope no closer than 5 % of the working length from the distal tip.

4.5.2 The minimum total area of the side apertures shall not be less than the cross-sectional area of the minimum instrument channel width.

4.5.3 The side apertures shall have a smooth rounded finish.

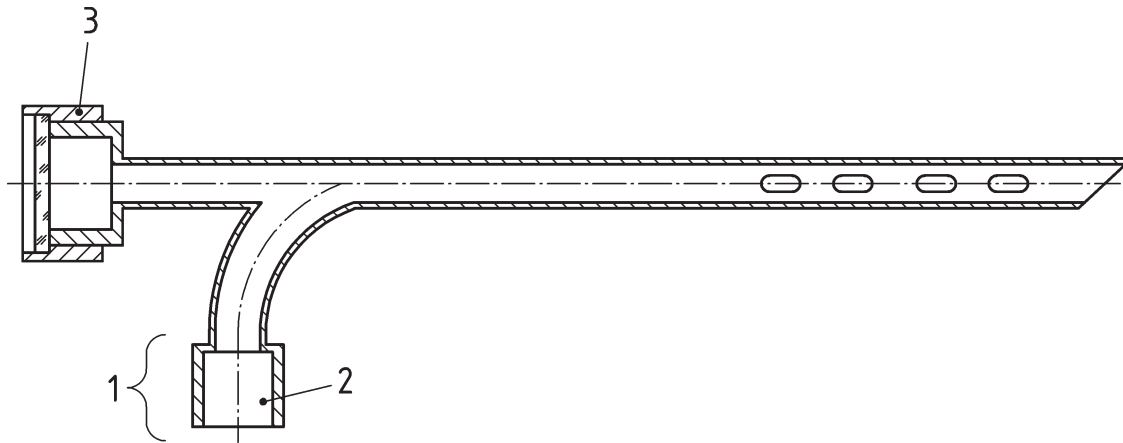

Key

- 1 connector for respiration and jet ventilation
- 2 15 mm male conical connector
- 3 end-cap closed

Figure 1 — Rigid ventilation bronchoscope with integrated ventilation connector

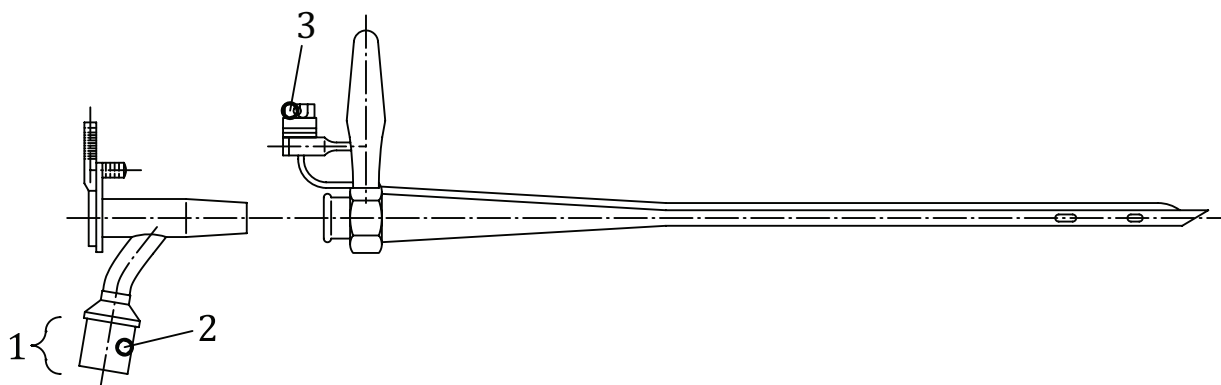

Key

- 1 connector for respiration and jet ventilation
- 2 15 mm male conical connector
- 3 fibre optic light guide

Figure 2 — Rigid ventilation bronchoscope with detachable ventilation connector — Detached

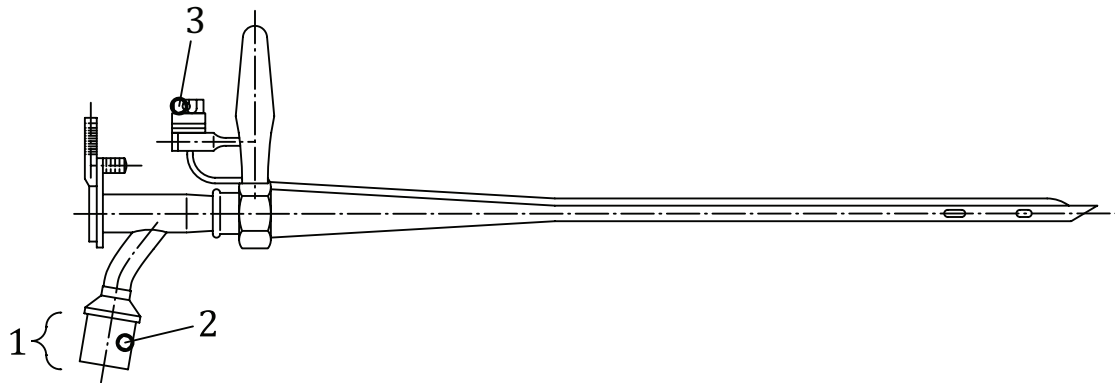

Key

- 1 connector for respiration and jet ventilation
- 2 15 mm male conical connector
- 3 fibre optic light guide

Figure 3 — Rigid ventilation bronchoscope with detachable ventilation connector — Assembled

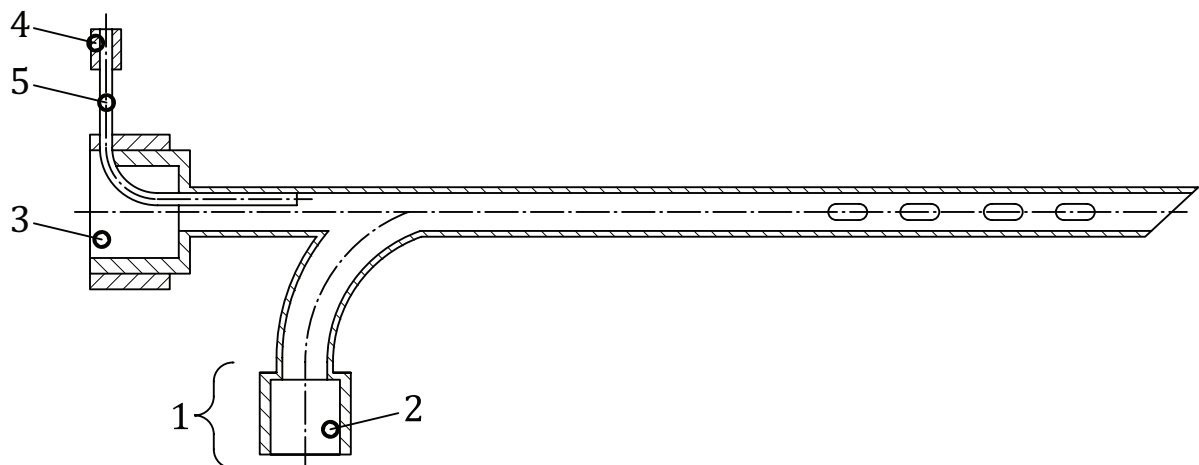

Key

- 1 connector for respiration and jet ventilation
- 2 15 mm male conical connector
- 3 open end
- 4 connector for jet-ventilation tubing
- 5 jet-injector

Figure 4 — Rigid bronchoscopes — Jet ventilation tubing

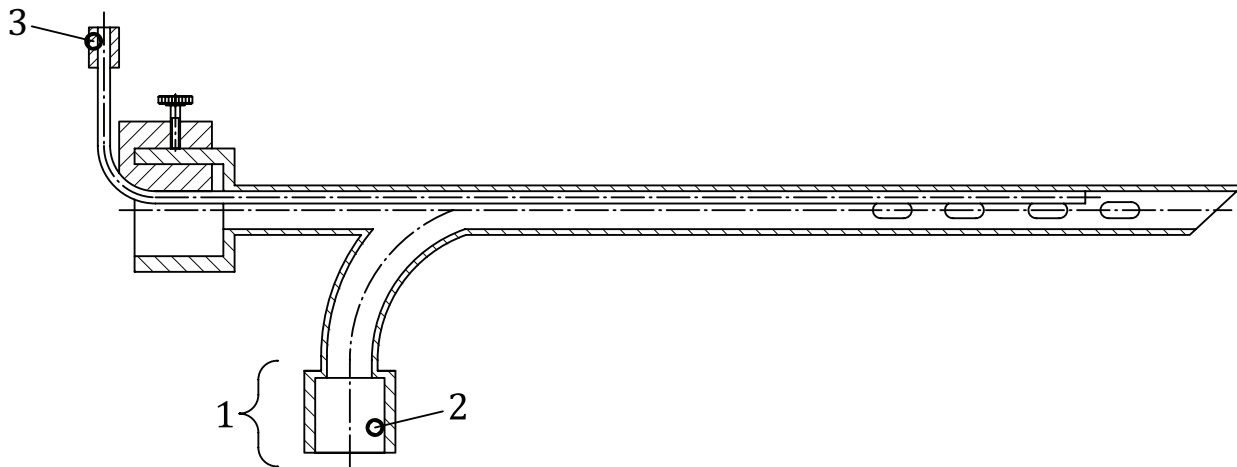

Key

- 1 connector for respiration and jet ventilation
- 2 15 mm male conical connector
- 3 long jet-injector with specific lock

Figure 5 — Rigid bronchoscopes — Long jet-injector with specific lock

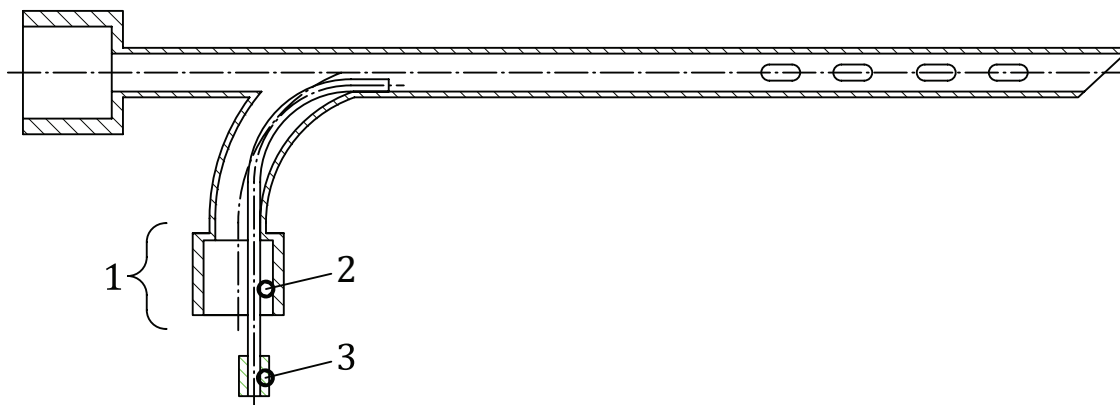

Key

- 1 connector for respiration and jet ventilation
- 2 15 mm male conical connector
- 3 jet-injector inserted through ventilation

Figure 6 — Rigid bronchoscopes — Jet injector inserted through ventilation

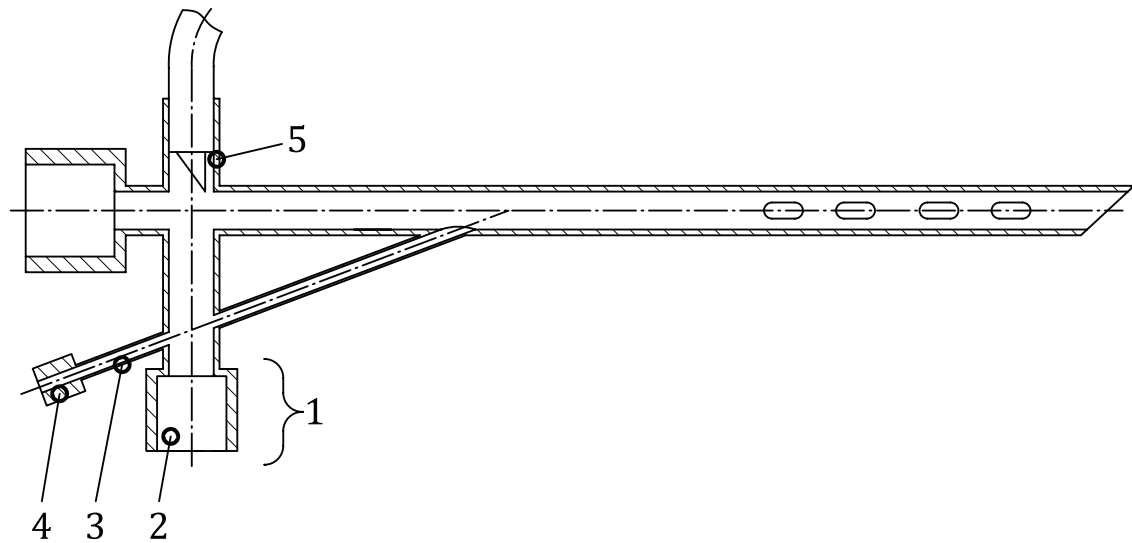

Key

- 1 connector for respiration and jet ventilation
- 2 15 mm male conical connector
- 3 channel for insertion of jet-injector
- 4 connector for jet-injector
- 5 prism in retracted position

Figure 7 — Rigid bronchoscopes — Jet injector

5 Testing

5.1 General

In addition to the test methods specified in ISO 8600-1:2013, Clause 5 (where applicable), the test methods specified in [5.2](#) to [5.5](#) apply.

5.2 Test method for pressure drop

5.2.1 Purpose

To determine the pressure drop through the rigid bronchoscope by introducing airflow at a specific flow rate and measuring the corresponding pressure drop expressed as gauge pressure (kPa).

5.2.2 Apparatus

5.2.2.1 Flow-measuring device, capable of measuring flows up to 70 l/min and having an accuracy of $\pm 5\%$.

5.2.2.2 Pressure-measuring device, having a time constant >10 s and an accuracy of $\pm 0,2$ kPa (± 2 cmH₂O).

5.2.2.3 Buffer reservoir, comprising a sealed jar of 5 l capacity with the air inlet placed near the bottom of the jar and the opening for the bronchoscope at the top of the jar (see [Figure 8](#)).

The open end of the tubing to the pressure-measuring device shall be placed in the jar halfway down and near the side of the jar.

5.2.3 Procedure

5.2.3.1 Carry out the test at (20 ± 3) °C.

5.2.3.2 Set up the apparatus as shown in [Figure 8](#) with the rigid bronchoscope inserted, ensuring that all seals are tight. If a prism is provided (see [Figure 7](#), key 5), ensure that it is fully advanced into the lumen of the rigid bronchoscope.

5.2.3.3 Adjust the airflow to the flow specified in [Table 1](#) and maintain this flow for 30 s.

[Table 1](#) gives typical values of the relationship between tube diameter, total length, flowrate and pressure drop.

Table 1 — Typical values of the relationship between tube diameter, total length, flowrate and pressure drop

Tube diameter (minimum insertion portion width) mm	Tube total length mm	Typical air flowrate l/min	Typical pressure drop kPa	
3,0	200	20	4,0	
	300		5,8	
3,5	200		30	2,3
	300			3,1
4,0	200	30	2,9	
	300		3,6	
4,5	200		40	1,7
	300			2,1
5,0	200	40	1,9	
	300		2,2	
5,5	200		50	1,3
	300			1,5
6,0	200	50	1,3	
	300		1,5	
6,5	200		50	0,9
	300			1,2
7,0	200	50	0,6	
	300		0,7	
7,5	200	50	0,4	
	300		0,5	

5.2.4 Expression of results

Record the reading on the pressure-measuring device.

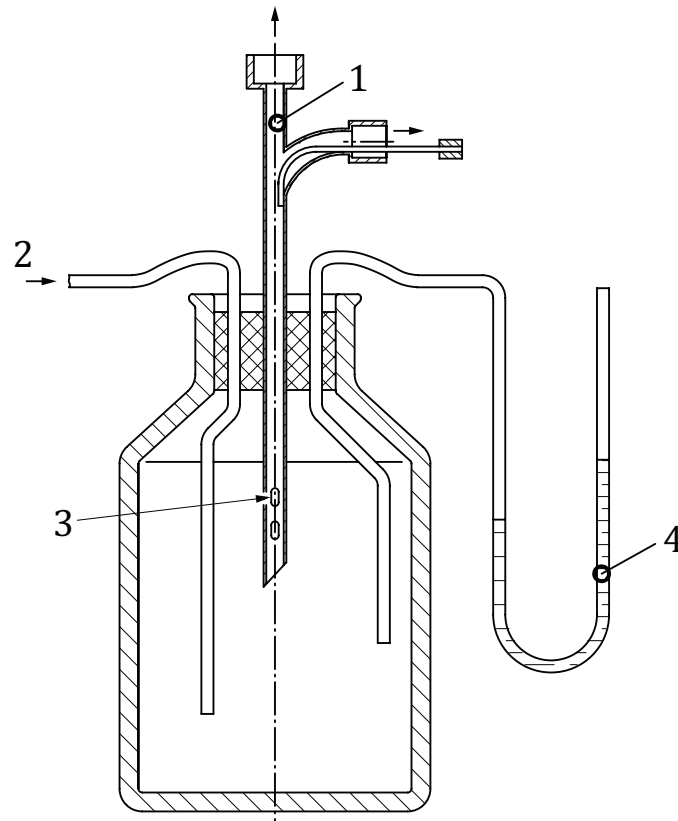

Key

- 1 rigid bronchoscope
- 2 air from flow measuring device
- 3 side holes to be within reservoir
- 4 pressure measuring device (e.g. water manometer)

Figure 8 — Apparatus for measuring pressure drop through a rigid bronchoscope

5.3 Test method for security of attachment of a jet-injector to the rigid bronchoscope

5.3.1 Purpose

The security of attachment is tested by applying a force in the axis of the jet-injector connection.

5.3.2 Apparatus

5.3.2.1 Rigid jet-injection bronchoscope, and jet-injector provided by the manufacturer.

5.3.2.2 Means, of applying a force of 20 N to the linear axis of the jet-injector connection.

5.3.2.3 Bracket, to hold a rigid jet-ventilation bronchoscope so that the jet-injector channel is in a vertical position.

5.3.3 Procedure

5.3.3.1 Carry out the test at $(20 \pm 3) ^\circ\text{C}$.

5.3.3.2 Attach the jet-injector to the rigid jet-ventilation bronchoscope as recommended by the manufacturer.

5.3.3.3 Mount the rigid jet-ventilation bronchoscope so that the jet-injector channel is in the vertical position (see [Figure 8](#)). Hang masses vertically to pull in the line of the axis of the jet-injector channel until a force of 20 N is reached or the jet-injector separates from the bronchoscope.

5.3.4 Expression of results

Note whether or not separation of jet-injector from the bronchoscope has occurred at the maximum test force (20 N).

5.4 Test method for container pressure with an open-ended jet-injector bronchoscope

5.4.1 Purpose

To determine the maximum air driving pressure to the jet-injector which provides a container pressure not exceeding 6,0 kPa (60 cmH₂O). The driving pressure is the static pressure downstream of the adjustable regulator.

5.4.2 Apparatus

See [Figure 9](#).

5.4.2.1 Rigid jet-ventilation bronchoscope.

5.4.2.2 Adjustable pressure regulator, (with 400 kPa supply).

5.4.2.3 4 l test container, which incorporates a test pressure gauge with a range of 0 kPa to 10,0 kPa (0 cmH₂O to 100 cmH₂O) and an accuracy of $\pm 0,2$ kPa ($\pm 2,0$ cmH₂O) and a sealed aperture that permits insertion of the patient end of the bronchoscope under test.

5.4.2.4 Clamp, to hold the bronchoscope in a test position. If a prism is provided (see [Figure 7](#), key 5), ensure that it is fully advanced into the lumen of the rigid bronchoscope.

5.4.3 Procedure

5.4.3.1 Carry out the test at (20 ± 3) °C.

5.4.3.2 Set the adjustable pressure regulator at 100 kPa, switch on the air line for 10 s and observe the container pressure. If the container pressure is greater than 6,0 kPa (60 cmH₂O), decrease the air driving pressure in increments of 10 kPa until the container pressure is less than 6,0 kPa (60 cmH₂O). If the container pressure is less than 6,0 kPa (60 cmH₂O), increase the air driving pressure in increments of 10 kPa until the container pressure exceeds 6,0 kPa (60 cmH₂O), or an air driving pressure of 400 kPa is reached, whichever comes first.

5.4.4 Expression of results

Record the maximum air driving pressure to the jet-injector which does not produce a container pressure greater than but the closest to 6,0 kPa (60 cmH₂O). This value is the maximum allowable air driving pressure (see [4.4.3](#)).

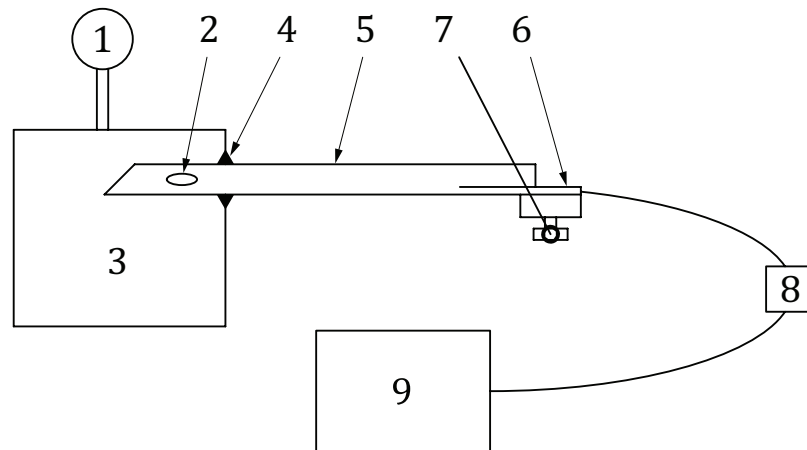

Key

- 1 test pressure gauge
- 2 side holes which are to be within test box
- 3 4 l test container
- 4 sealed aperture
- 5 bronchoscope under test
- 6 jet-injector
- 7 lock
- 8 ON/OFF switch
- 9 adjustable pressure regulator

Figure 9 — Schematic apparatus for testing maximum air driving pressure to a jet-injector in a rigid jet-ventilation bronchoscope

5.5 Test method for minimum instrument channel width

5.5.1 Purpose

The minimum instrument channel width is determined by passage of a calibrated measuring device such as a steel ball through the rigid bronchoscope. If a light carrier is provided, the measurement shall be made with the light carrier in place.

5.5.2 Apparatus

5.5.2.1 Stand with clamp, to hold the bronchoscope with its axis in a vertical position with the proximal end up.

5.5.2.2 Steel ball, with a diameter of $\left(100 \begin{smallmatrix} -1 \\ 0 \end{smallmatrix}\right)\%$ the minimum instrument channel width of the rigid bronchoscope under test.

5.5.3 Procedure

5.5.3.1 Carry out the test at $(20 \pm 3) ^\circ\text{C}$.

5.5.3.2 Clamp the bronchoscope in a vertical position with the proximal end uppermost. Drop the steel ball through the lumen of the bronchoscope. The steel ball shall pass freely through the lumen.

5.5.4 Expression of results

Record whether or not the steel ball passes freely through the lumen of the bronchoscope.

6 Marking

Rigid bronchoscopes shall be marked in accordance with ISO 8600-1.

7 Instruction manual

7.1 ISO 8600-1:2013, Clause 7 applies, together with the following.

- a) Items e) 4), f), h) 1), and h) 2) of ISO 8600-1:2013, Clause 7 do not apply.
- b) Item e) 3) of ISO 8600-1:2013, Clause 7 is amended as follows:
 - maximum insertion portion width and working length; the following precaution shall be given in the instruction manual, if necessary: “There is no guarantee that instruments selected solely using maximum insertion portion width and working length will be compatible in combination.”
- c) Item e) of ISO 8600-1:2013, Clause 7 is amended by the addition of the following:
 - the relationship between the minimum instrument channel width, flow rate and maximum pressure developed by the instrument when tested in accordance with [5.2](#).
- d) Item b) of ISO 8600-1:2013, Clause 7 applies together with the following:
 - 1) a statement whether the rigid bronchoscope is applicable to controlled/assisted ventilation or jet-ventilation, or both;
 - 2) a statement of the maximum air driving pressure as determined in [5.4](#) for rigid jet-ventilation bronchoscopes.
- e) Item h) of ISO 8600-1:2013, Clause 7 is amended as follows:
 - “precautions and instructions applicable for the intended uses of the instrument, including those related to electrical, electronic, electro-optical, electro-medical, electro-acoustical or ventilation apparatus intended to be used with the instrument.”

7.2 The maximum pressure as measured in accordance with [5.4](#) when that pressure is less than 400 kPa.

7.3 When a jet-injector is used with a rigid ventilation bronchoscope that has no side-holes, the operator shall be informed of changes in gas dynamics that can result in a potential increase of lung insufflation pressure.

8 Packaging

Rigid bronchoscopes should be packaged as specified in ISO 8600-1.

Annex A (informative)

Rationale

A.1 General

This Annex provides a rationale for some requirements of this part of ISO 8600 and is intended for those who are familiar with the subject of this part of ISO 8600 but who have not participated in its development. An understanding of the rationale underlying these requirements is considered to be essential for their proper application.

Clause 1 This clause defines the scope of this part of ISO 8600, where all rigid bronchoscopes are covered, while they should be usable as rigid ventilation bronchoscopes or rigid jet-ventilation bronchoscopes respectively, as defined in, or both, whenever needed to ventilate patients.

Clause 2 The rigid ventilation bronchoscope is an instrument employed by the otolaryngologist, thoracic surgeon and chest physician as well as the anaesthetist and may be used in the presence of other anaesthetic and respiratory equipment. The rigid bronchoscope provides a channel for air passage to and/or from the lungs of the patient. ISO 5356-1 especially specifies dimensions of connectors used with other anaesthetic and respiratory equipment.

4.2 The length of a rigid bronchoscope is an important characteristic for use in the selection of a particular instrument to conform to anatomical attributes. The working length is of most concern. This requirement defines the labelled working length as the minimum and permits the actual working length to be up to 10 mm longer than the labelled working length.

4.3.1 The availability of a safe, secure but interchangeable connection between the rigid bronchoscope and the breathing system of an anaesthetic or breathing machine is an essential function of ventilation connectors. This can be achieved by an integral side-arm type connector (15 mm male conical) or by using a detachable adapter with the same connector (in accordance with ISO 5356-1) in the side arm.

Provision should be made to allow an operator the access from the side. Ventilation connectors in a side arm which allows some rotation (swivel) around the shaft of the bronchoscope permits better manoeuvrability for both bronchoscopist and anaesthetist.

4.4.1 It is important that a means of jet ventilation is available to manage the patient when frequent suctioning, diathermy, laser ablation or biopsy is required. In these circumstances, an open bronchoscope is needed but the patient still has to be ventilated. The usual method for achieving this is jet ventilation.

4.4.2 A robust connection is required to withstand the sudden loading of repeated jetting.

4.4.3 If the intra-thoracic pressure exceeds 6,0 kPa (60 cmH₂O), the risk of pneumothorax becomes clinically significant. At 10 kPa (100 cmH₂O), the risk becomes substantial. Unfortunately, many patients who require bronchoscopy have abnormal lungs, but also many have a low compliance. Thus, a compromise value of 6,0 kPa (60 cmH₂O) has been set for the test. The use of jetting should always be adjusted to allow for variations in the patient's condition.

The responsibility in safety of jet-ventilation rests entirely with the physician.

4.5.1 Side apertures reduce the build-up in pressure if the tip is occluded or down into one bronchus. The intent is to have extensive openings which will optimize the ventilation of both lungs even when the bronchoscope is inserted down only into one bronchus.

4.5.2 A large total area of the side apertures helps to reduce the intrathoracic pressure if the tip is occluded or down into one bronchus. The intent is to optimize the ventilation of both lungs even when bronchoscopy and associated procedures are being done down only into one bronchus.

4.5.3 A rough finish or sharp edge to the apertures can result in incidental coring or excision of bronchial epithelium.

5.2 All rigid bronchoscopes should allow adequate ventilation for the patient, either as spontaneous ventilation or as controlled ventilation. As resistance to breathing increases, more effort is required with spontaneous ventilation and thus the risk of hypercarbia and hypoxia increases. With jet ventilation, as resistance increases, the tidal volume of respiration decreases and hypercarbia and hypoxia can occur. Similarly, an increased resistance with controlled ventilation means that inadequate expiration can occur during the bronchoscopy. This may not decrease ventilation but can cause a rise in intrathoracic pressure which itself can reduce cardiac output. It may be especially so with a jet-ventilation bronchoscope causing higher expiratory resistance. The bronchoscope resistance specified is the highest that can be used without a considerable risk of causing major physiological changes. Bronchoscopes which are intended for a range of patients should conform to the lowest resistance figures; e.g. a small bronchoscope suitable for use with adolescents and children should have a flow resistance of not more than 1,8 kPa (18 cmH₂O) at the specified flowrate.

7.1 c) Some ventilation apparatus are purely mechanical.

7.1 d) This is to minimize the risk of pneumothorax as outlined in the rationale for [4.4.3](#), using the commonly available supply pressure or less pressure. It sets an upper limit for the risk.

Bibliography

- [1] ISO 8600-6, *Optics and photonics — Medical endoscopes and endotherapy devices — Part 6: Vocabulary*

British Standards Institution (BSI)

BSI is the national body responsible for preparing British Standards and other standards-related publications, information and services.

BSI is incorporated by Royal Charter. British Standards and other standardization products are published by BSI Standards Limited.

About us

We bring together business, industry, government, consumers, innovators and others to shape their combined experience and expertise into standards-based solutions.

The knowledge embodied in our standards has been carefully assembled in a dependable format and refined through our open consultation process. Organizations of all sizes and across all sectors choose standards to help them achieve their goals.

Information on standards

We can provide you with the knowledge that your organization needs to succeed. Find out more about British Standards by visiting our website at bsigroup.com/standards or contacting our Customer Services team or Knowledge Centre.

Buying standards

You can buy and download PDF versions of BSI publications, including British and adopted European and international standards, through our website at bsigroup.com/shop, where hard copies can also be purchased.

If you need international and foreign standards from other Standards Development Organizations, hard copies can be ordered from our Customer Services team.

Subscriptions

Our range of subscription services are designed to make using standards easier for you. For further information on our subscription products go to bsigroup.com/subscriptions.

With **British Standards Online (BSOL)** you'll have instant access to over 55,000 British and adopted European and international standards from your desktop. It's available 24/7 and is refreshed daily so you'll always be up to date.

You can keep in touch with standards developments and receive substantial discounts on the purchase price of standards, both in single copy and subscription format, by becoming a **BSI Subscribing Member**.

PLUS is an updating service exclusive to BSI Subscribing Members. You will automatically receive the latest hard copy of your standards when they're revised or replaced.

To find out more about becoming a BSI Subscribing Member and the benefits of membership, please visit bsigroup.com/shop.

With a **Multi-User Network Licence (MUNL)** you are able to host standards publications on your intranet. Licences can cover as few or as many users as you wish. With updates supplied as soon as they're available, you can be sure your documentation is current. For further information, email bsmusales@bsigroup.com.

BSI Group Headquarters

389 Chiswick High Road London W4 4AL UK

Revisions

Our British Standards and other publications are updated by amendment or revision.

We continually improve the quality of our products and services to benefit your business. If you find an inaccuracy or ambiguity within a British Standard or other BSI publication please inform the Knowledge Centre.

Copyright

All the data, software and documentation set out in all British Standards and other BSI publications are the property of and copyrighted by BSI, or some person or entity that owns copyright in the information used (such as the international standardization bodies) and has formally licensed such information to BSI for commercial publication and use. Except as permitted under the Copyright, Designs and Patents Act 1988 no extract may be reproduced, stored in a retrieval system or transmitted in any form or by any means – electronic, photocopying, recording or otherwise – without prior written permission from BSI. Details and advice can be obtained from the Copyright & Licensing Department.

Useful Contacts:

Customer Services

Tel: +44 845 086 9001

Email (orders): orders@bsigroup.com

Email (enquiries): cservices@bsigroup.com

Subscriptions

Tel: +44 845 086 9001

Email: subscriptions@bsigroup.com

Knowledge Centre

Tel: +44 20 8996 7004

Email: knowledgecentre@bsigroup.com

Copyright & Licensing

Tel: +44 20 8996 7070

Email: copyright@bsigroup.com



...making excellence a habit.™