

Compressed air —

Part 2: Test methods for oil aerosol content

ICS 71.100.20

National foreword

This British Standard was published by BSI. It is the UK implementation of ISO 8573-2:2007. It supersedes BS ISO 8573-2:1996 which is withdrawn.

The UK participation in its preparation was entrusted by Technical Committee MCE/8, Compressors, pneumatic tools, pneumatic machines and vacuum technology, to Panel MCE/8/-/3, Air quality.

A list of organizations represented on MCE/8/-/3 can be obtained on request to its secretary.

This publication does not purport to include all the necessary provisions of a contract. Users are responsible for its correct application.

Compliance with a British Standard cannot confer immunity from legal obligations.

This British Standard was published under the authority of the Standards Policy and Strategy Committee on 28 February 2007

© BSI 2007

ISBN 978 0 580 50283 5

Amendments issued since publication

Amd. No.	Date	Comments

INTERNATIONAL
STANDARD

ISO
8573-2

Second edition
2007-02-01

Compressed air —

Part 2:

Test methods for oil aerosol content

Air comprimé —

Partie 2: Méthodes d'essai pour la détermination de la teneur en aérosols d'huile



Reference number
ISO 8573-2:2007(E)

Contents

Page

Foreword.....	iv
1 Scope	1
2 Normative references	1
3 Terms and definitions	1
4 Units	2
5 Reference conditions	2
6 Guide for selection of test method	2
7 General description of test equipment and method	2
7.1 Method A	2
7.2 Method B	4
8 Test procedure — Method A	8
8.1 General	8
8.2 Measuring procedure	8
8.3 Calculation of test results	11
8.4 Presentation of results	11
9 Test procedures — Method B	11
9.1 Oil vapour	11
9.2 Maximum air velocity	11
9.3 Temperature	11
9.4 Handling	12
9.5 Blank sample	12
9.6 Preparation	12
9.7 Test method B1	12
9.8 Test method B2	13
10 Analytical procedure for methods B1 and B2	13
10.1 Principle	13
10.2 Solvent	14
10.3 Apparatus	14
10.4 Procedure — Analysis of oil collected by the membrane	14
11 Test result processing	16
11.1 Preparation of the calibration graph	16
11.2 Calculation of test results	18
12 Uncertainty of the method	18
Annex A (informative) Typical test report	19
Annex B (informative) Typical equipment layout and dimensional details	20
Bibliography	25

Foreword

ISO (the International Organization for Standardization) is a worldwide federation of national standards bodies (ISO member bodies). The work of preparing International Standards is normally carried out through ISO technical committees. Each member body interested in a subject for which a technical committee has been established has the right to be represented on that committee. International organizations, governmental and non-governmental, in liaison with ISO, also take part in the work. ISO collaborates closely with the International Electrotechnical Commission (IEC) on all matters of electrotechnical standardization.

International Standards are drafted in accordance with the rules given in the ISO/IEC Directives, Part 2.

The main task of technical committees is to prepare International Standards. Draft International Standards adopted by the technical committees are circulated to the member bodies for voting. Publication as an International Standard requires approval by at least 75 % of the member bodies casting a vote.

Attention is drawn to the possibility that some of the elements of this document may be the subject of patent rights. ISO shall not be held responsible for identifying any or all such patent rights.

ISO 8573-2 was prepared by Technical Committee ISO/TC 118, *Compressors and pneumatic tools, machines and equipment*, Subcommittee SC 4, *Quality of compressed air*.

This second edition cancels and replaces the first edition (ISO 8573-2:1996), which has been technically revised.

ISO 8573 consists of the following parts, under the general title *Compressed air*:

- *Part 1: Contaminants and purity classes*
- *Part 2: Test methods for oil aerosol content*
- *Part 3: Test methods for measurement of humidity*
- *Part 4: Test methods for solid particle content*
- *Part 5: Test methods for oil vapour and organic solvent content*
- *Part 6: Test methods for gaseous contaminant content*
- *Part 7: Test method for viable microbiological contaminant content*
- *Part 8: Test methods for solid particle content by mass concentration*
- *Part 9: Test methods for liquid water content*

Compressed air —

Part 2: Test methods for oil aerosol content

1 Scope

This part of ISO 8573 specifies test methods for the sampling and quantitative analysis of oil aerosols and liquid oil that can typically be present in compressed air. Test methods for oil vapour are excluded from this part of ISO 8573 as they are covered by ISO 8573-5.

Two different methods are described, method A and method B. Method B is subdivided into two parts to clearly distinguish between procedures for obtaining the quantity of oil for analysis.

2 Normative references

The following referenced documents are indispensable for the application of this document. For dated references, only the edition cited applies. For undated references, the latest edition of the referenced document (including any amendments) applies.

ISO 8573-1, *Compressed air — Part 1: Contaminants and purity classes*

ISO 8573-5, *Compressed air — Part 5: Test methods for oil vapour and organic solvent content*

ISO 12500-1, *Filters for compressed air — Test method — Part 1: Oil aerosols*

3 Terms and definitions

For the purposes of this document, the terms and definitions given in ISO 8573-1 and the following apply.

3.1

oil

mixture of hydrocarbons composed of six or more carbon atoms, i.e., C₆₊

3.2

oil aerosol

mixture of liquid oil suspended in a gaseous medium having negligible fall velocity/settling velocity

3.3

wall flow

that proportion of liquid contamination no longer suspended within the air flow of the pipe

4 Units

General use of SI units (Système international d'unités; see ISO 1000) as given throughout this International Standard is recommended. However, in agreement with accepted practice in the pneumatic field, some non-preferred SI units, accepted by ISO, are also used.

$$1 \text{ bar} = 100\,000 \text{ Pa}$$

NOTE Bar(e) is used to indicate effective pressure above atmospheric.

$$1 \text{ l (litre)} = 0,001 \text{ m}^3$$

5 Reference conditions

Reference conditions for oil aerosol content volume statements are as follows:

air temperature	20 °C
absolute air pressure	100 kPa [1 bar (a)]
relative water vapour pressure	0

6 Guide for selection of test method

The test methods may be used at any point in the compressed air system. The choice between methods A and B depends upon the actual level of oil contamination present in the compressed air system, as shown in Table 1. Where wall flow is present, then method A shall be used.

Table 1 — Guide for the selection of test method

Parameter	Method A Full flow	Method B1 Full flow	Method B2 Partial flow
Contamination range	1 mg/m ³ to 40 mg/m ³	0,001 mg/m ³ to 10 mg/m ³	0,001 mg/m ³ to 10 mg/m ³
Max. velocity in filter	See 7.1.2.10	1 m/s	1 m/s
Sensitivity	0,25 mg/m ³	0,001 mg/m ³	0,001 mg/m ³
Accuracy	± 10 % of actual value	± 10 % of actual value	± 10 % of actual value
Max. temperature	100 °C	40 °C	40 °C
Testing time (typical)	50 h to 200 h	2 min to 10 h	2 min to 10 h
Filter construction	Coalescing line filter	Three-layer membrane	Three-layer membrane

7 General description of test equipment and method

7.1 Method A

7.1.1 General

This test method is suitable for full flow and samples all of the air flow that is passed through two high-efficiency coalescing filters in series and measures oil in both aerosol and wall-flow forms. It is unsuitable for performing measurements in systems where steady-state flow, temperature and pressure cannot be maintained.

This test method may be used at any point in a compressed-air system where heavy contamination levels of oil are believed to exist.

The test equipment shall be in good working order. Bends and elbows are not permitted. All valves shall be closed and the test equipment checked for leaks by pressurizing, by opening the shut-off valve (key item 2 in Figure 1).

7.1.2 Test equipment

7.1.2.1 General description

The typical arrangement of equipment used in Method A is shown in Figure 1. The test equipment should not influence the collection sample.

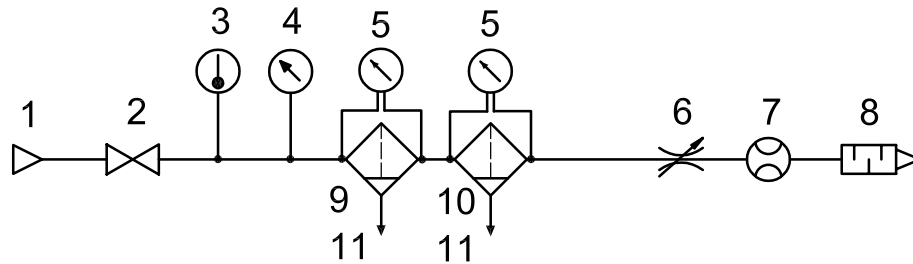

Key

1	compressed air sampling point	7	flow sensing/measuring
2	full-flow ball valve	8	silencer
3	temperature sensing/measuring	9	sampling filter
4	pressure sensing/measuring	10	back-up filter
5	differential pressure gauge	11	liquid collection
6	multi-turn flow control valve		

Figure 1 — Typical arrangement for method A

7.1.2.2 Compressed air sampling point (Figure 1, key item 1)

The compressed-air sampling point is a test point at a nominated site in the compressed-air system under investigation.

7.1.2.3 Shut-off valve (Figure 1, key item 2)

This is an optional item for convenient connection to the test point.

7.1.2.4 Temperature sensing/measuring (Figure 1, key item 3)

A temperature sensing/indicating device is used to indicate the compressed air sampling point temperature at the time of the test.

7.1.2.5 Pressure sensing/measuring (Figure 1, key item 4)

A pressure-sensing/indicating device is used to confirm that the coalescing filters are operating within manufacturer's specifications.

7.1.2.6 Differential pressure gauge (Figure 1, key item 5)

These gauges determine the pressure drop across the sample and back-up filters.

7.1.2.7 Flow control valve (Figure 1, key item 6)

In order to adjust the flow accurately, a valve with fine adjustment is required.

7.1.2.8 Flow sensing/measuring (Figure 1, key item 7)

A suitable flow meter with an accuracy of $\pm 5\%$ of the actual value is used to determine the air sample volume, which shall be referred to reference conditions; see Figure 1, key item 7.

7.1.2.9 Silencer (Figure 1, key item 8)

This is to limit the noise during the test and assist in meeting any local noise-reduction requirements.

7.1.2.10 Sampling filter (Figure 1, key item 9)

The sampling filter is a high-efficiency, coalescing filter capable of removing the oil whose concentration is being measured from the upstream concentration and of reducing the downstream concentration to $0,01 \text{ mg/m}^3$ or less as determined by ISO 12500-1.

Flow rate through the sampling filter shall not exceed the manufacturers' recommendation for the test pressure.

The measurements are only valid once the filter has reached steady state conditions.

7.1.2.11 Back-up filter (Figure 1, key item 10)

This filter is identical to the sampling filter and, in the event of malfunction of the sampling filter, collects any oil, that passes through it.

7.1.2.12 Liquid collection (Figure 1, key item 11)

The liquid collected in the sampling or back-up filters (items 9 and 10, respectively), is discharged to a suitable measuring device, graduated in millilitres.

Necessary precautions when discharging the liquid include care in controlling the liquid flow and any subsequent rapid escape of compressed air that can cause the collected oil to foam. In addition, if air bubbles appear in the collected liquid, then allow time for settling before taking a reading. The mass of the oil can be directly measured in milligrams by weighing.

7.2 Method B

The method is subdivided into procedures B1 and B2. Method B2 uses the same test equipment employed in method B1; with the addition of a sampling probe to allow partial-flow sampling under isokinetic conditions from the main pipe flow if the velocity constraints of method B1 are exceeded. Accuracy and limitations are as stated in method B1.

7.2.1 Method B1 — Full-flow sampling

Method B1 deals with the sampling and analysis of oil aerosols at constant flow rate. Within the constraints detailed above, this method permits the quantification of oil aerosols present in a compressed air system, provided wall-flow contamination is not present.

All of the air flow is diverted through the test equipment via suitable in-line valves, which have been previously checked to ensure they do not contribute to the level of oil contamination already present. As this method concerns the measurement of relatively low concentrations of oil in air, particular attention shall be paid to the cleanliness of the test equipment and other precautions shall be taken, e.g. valve purging and stabilization to constant test conditions. Good analytical techniques help improve the confidence level of the measurements.

The optimum duration of a test measurement may be determined after an initial test to determine the approximate oil concentration present. When carrying out full-flow tests, it is possible to route the air back into the compressed air system, preventing loss of the product. Conversely, it is also possible to vent the flow to the atmosphere. Flow measurement is required to determine the volume of air used during the test, whichever method is adopted. As the test apparatus is portable, different test locations may be chosen provided the stated parameters are not exceeded and suitable valving for insertion of the test equipment into the circuit exists. Obvious precautions to prevent shock depressurization, which can damage the test filter membrane, or ingress of atmospheric contamination are necessary.

The sampling and analysing equipment used as described give an accuracy of better than $\pm 10\%$ over the range from $0,001 \text{ mg/m}^3$ to approximately 10 mg/m^3 oil content with a minimum sampling time calculated to collect sufficient oil to meet the requirements of the oil mass-per-volume of solvent as stated in 11.2.1. The upper limit for the air velocity (at operating pressure) in front of the test membrane is 1 m/s . The test is performed under full-flow conditions.

At very low oil concentration the recommended sampling time is increased to 1 h or more.

7.2.1.1 Test equipment

A general arrangement of typical test equipment is shown in Figure 2.

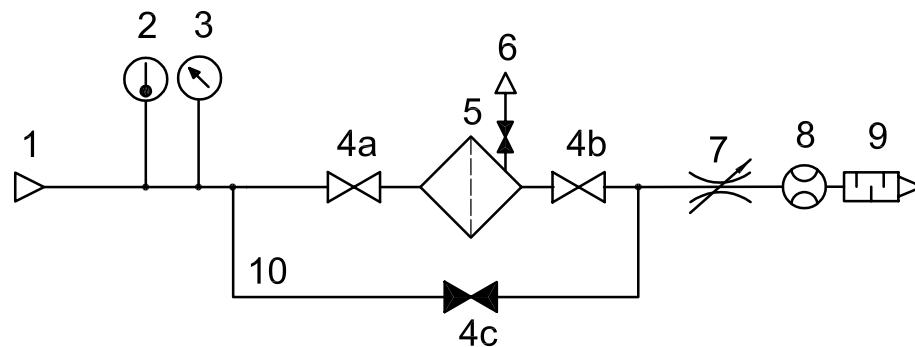

Key

1	compressed-air sampling point	6	membrane holder depressurising valve
2	temperature sensing/measuring	7	multi-turn flow control valve
3	pressure sensing/measuring	8	flow sensing/measuring
4a to 4c	full-flow ball valves	9	silencer
5	membrane holder	10	bypass pipe

Figure 2 — Typical arrangement for method B1

7.2.1.1.1 Membrane

In order to obtain good measuring accuracy, a high-efficiency micro-fibreglass membrane should be used. Where the membrane utilizes a binder, this shall not affect the results of the analysis. To achieve the accuracy specified for this method, three layers of membrane in series and in intimate contact shall be used and the membrane shall meet the requirements given in Table 2.

Table 2 — High-efficiency micro-fibreglass membrane

Parameter	Specification
Surface mass, g/m^2	80 to 100
Particle penetration, %	$< 0,0005$

7.2.1.1.2 Membrane support

In order to prevent the collection membrane from bursting, it shall be supported by a robust, inert material that is sufficiently strong to withstand the differential pressures of the membranes in use during the test. The pressure-drop losses from the support should be minimized to allow the test compressed air flow to pass with a minimum of resistance; see Figure B.3.

7.2.1.1.3 Pipes and valves

It is important that the pipe inner diameter from the connection point in the compressed air system to the membrane holder be constant and crevice free to minimize system loss.

The shut-off valves (key items 4a to 4c in Figure 2) should be full-flow ball type and the hole in the ball should have approximately the same diameter as the pipe.

The bypass pipe may consist of a flexible tube and although full-flow ball valve (key items 4a to 4c in Figure 2) is indicated, this may be of any convenient type.

7.2.1.1.4 Membrane holder

Any readily available membrane holder that accepts circular membranes may be used, taking note of 7.2.1.1.5. A general diagram of a typical membrane holder and description are given in Figure B.4.

7.2.1.1.5 Construction materials

Aluminium and its alloys shall not be used for any component that can come into contact with the solvents.

7.2.2 Method B2 — Partial-flow sampling

7.2.2.1 General

It is necessary to know both main pipe flow and sample flows to define the test conditions.

This method employs a sampling probe, which is inserted into any section of the compressed air system using suitable connections and valves and allows a sample of air to be taken from the main pipe flow under identical velocity conditions. The probe may be inserted to an approximately central position across the main pipe diameter and it is recommended that a number of preliminary tests be made.

The pressure seals used in the probe/holder connectors shall not release any hydrocarbon into solution when immersed in the analysing solvent. It is impractical to return the sample flow to the main pipe flow downstream from the membrane holder, and it is usual to vent this flow to atmosphere.

A typical probe design is shown in Figure B.3.

7.2.2.2 Test equipment

A general arrangement of typical test equipment is shown in Figure 3.

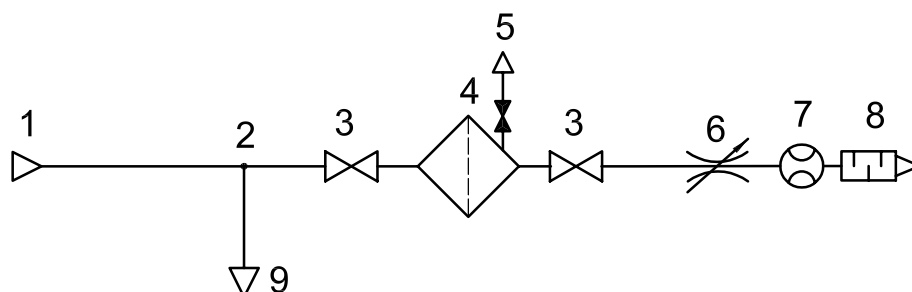

Key

- | | | |
|------------------------------------|--|--------------------------------------|
| 1 compressed air supply (upstream) | 4 membrane holder | 7 flow sensing/measuring |
| 2 isokinetic probe insertion point | 5 membrane holder depressurising valve | 8 silencer |
| 3 full-flow ball valve | 6 multi-turn flow control valve | 9 compressed air supply (downstream) |

Figure 3 — Typical arrangement for method B2

7.2.2.3 Compressed air flow-rates

The air velocities within the main pipeline and within the probe shall be identical throughout the sampling period. This is accomplished through adjustment of the flow controllers to provide appropriate readings on the flow meters.

Verification of identical pipe and probe velocities can be evaluated by the following procedures.

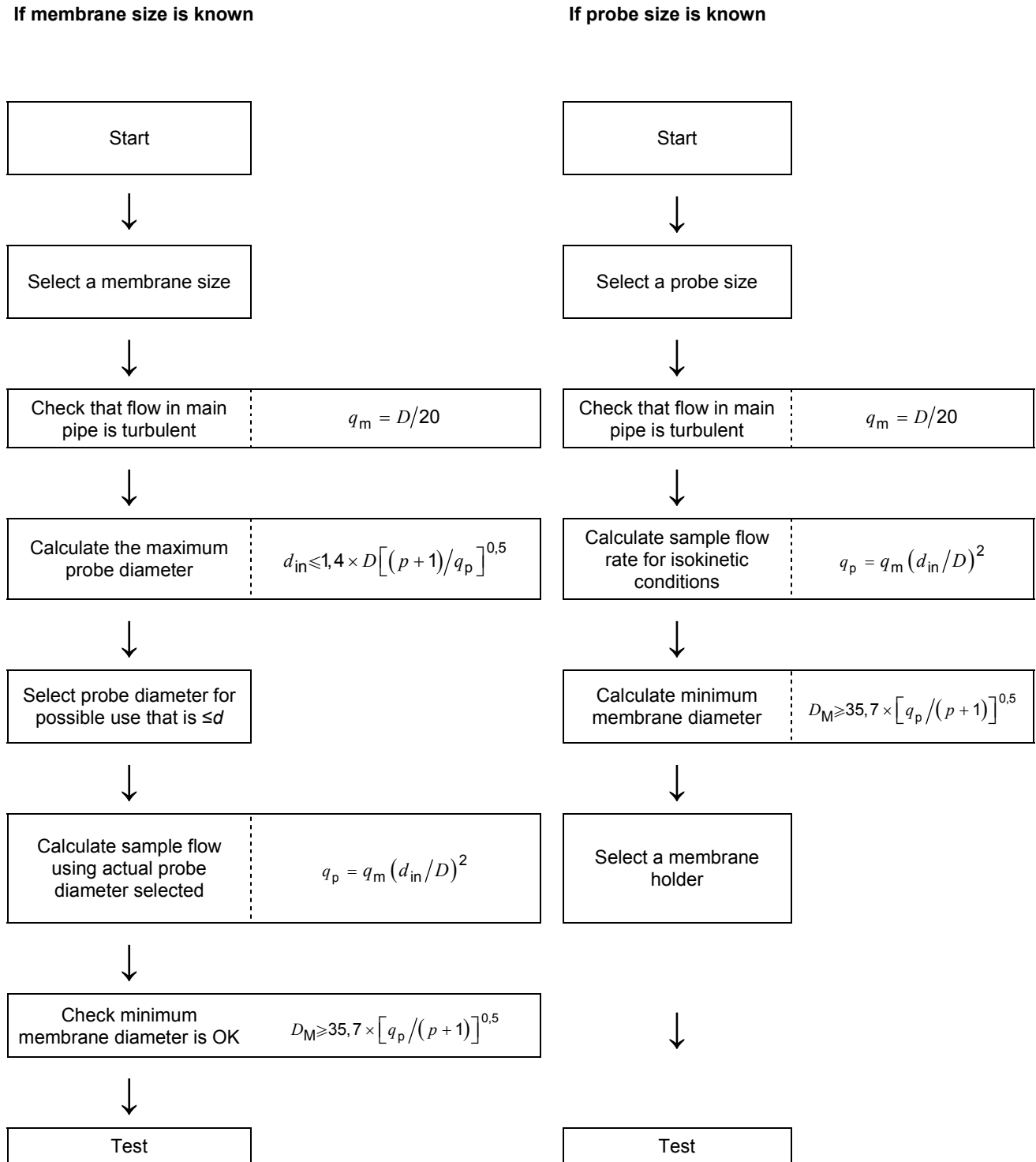

where

q_m is the flow in main pipe, expressed in litres per second (at reference conditions)

q_p is the flow in probe, expressed in litres per second (at reference conditions)

d_{in} is the internal diameter of probe, expressed in millimetres

D is the internal diameter of pipe, expressed in millimetres

D_M is the membrane diameter, expressed in millimetres

p is the system pressure, expressed in pascals [bar(e)]

8 Test procedure — Method A

8.1 General

8.2 Measuring procedure

8.2.1 Start-up

All valves should be in the closed position at the beginning of the test.

Open shut-off valve (key item 2, Figure 1) fully to pressurize the test equipment. Adjust flow using flow control valve (key item 6, Figure 1) to required flow conditions shown on the flow sensing/measuring device (key item 7, Figure 1).

Close valves to liquid collection (key items 11, Figure 1).

8.2.2 Stabilizing sampling filter

The sampling filter element (key item 9, Figure 1) operates in a saturated condition and time shall be allowed for this condition to be reached.

Measurement shall be taken only when the differential pressure of the sampling filter reaches the stable part of the graph (Figure 4) and oil is visible in the filter bowl of the sampling filter (key item 9, Figure 1).

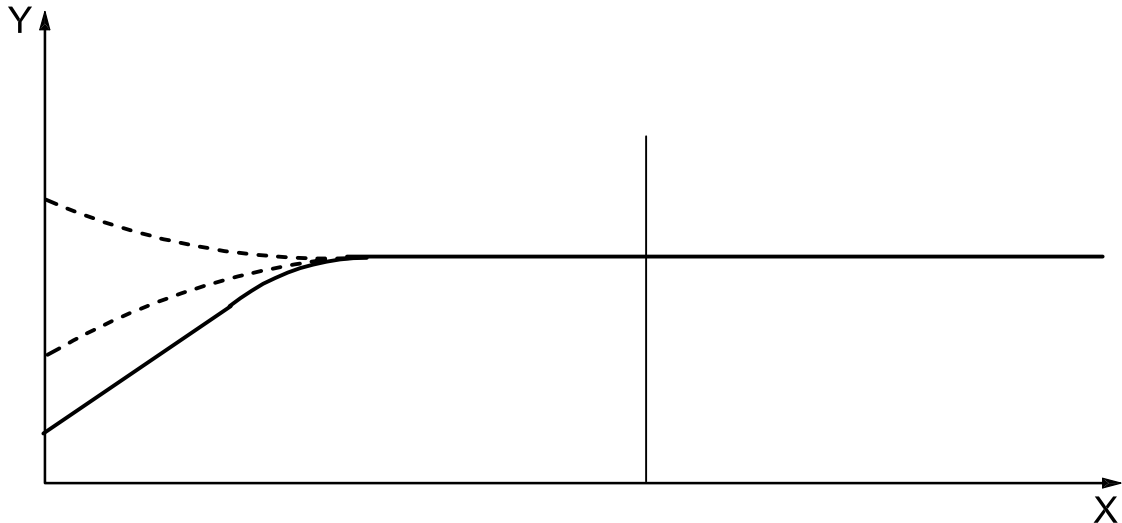
**Key**

X time

Y pressure drop across sampling filter

— characteristic curve for unused sampling filter

- - - characteristic curve for previously used sampling filter

Figure 4 — Characteristic curves for sampling filters

A stable pressure drop is indicated by the differential pressure gauge (key item 5, Figure 1). An unused sampling filter takes longer to reach a stable condition than a filter that has previously been used. The time required to reach a stable pressure drop depends on the oil/water loading.

8.2.3 Oil measurement

Drain the oil for measurement from sampling filter (key item 9, Figure 1) and collect the liquid in a suitable volumetric measuring device. Measuring intervals depend upon the amount of liquid collected. Allow the collected oil to separate in order to avoid incorrect readings due to foaming, and take care during measurement to account for the meniscus. Alternatively, the collected oil may be weighed and the mass recorded in milligrams.

The first sampling filter (key item 9, Figure 1) collects the oil to the required accuracy. The back-up filter (key item 10, Figure 1) is used to ensure the first sampling filter has functioned correctly. Any sign of oil in the second filter indicates that it is necessary to replace the first filter element.

8.2.4 Oil/water measurements

The condensed liquid shall always be collected in a container compatible with the liquid collected.

The liquid collected consists of water, oil/water, emulsion and oil. Depending on the type of oil, separation of the oil/water emulsion can occur, allowing the water to be drained off and the oil to be measured; see Figure 5.

If a water/oil emulsion zone occurs, drain the oil-free water then add a measured quantity of solvent and stir to dissolve the oil; see Figure 6.

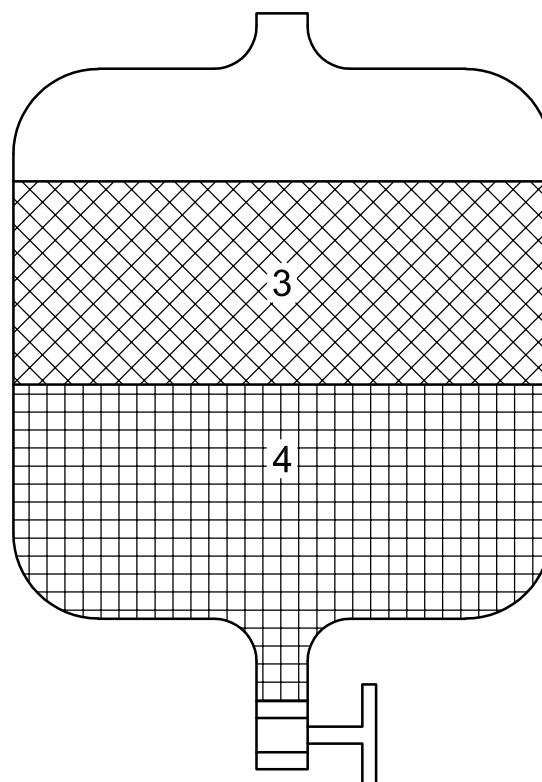
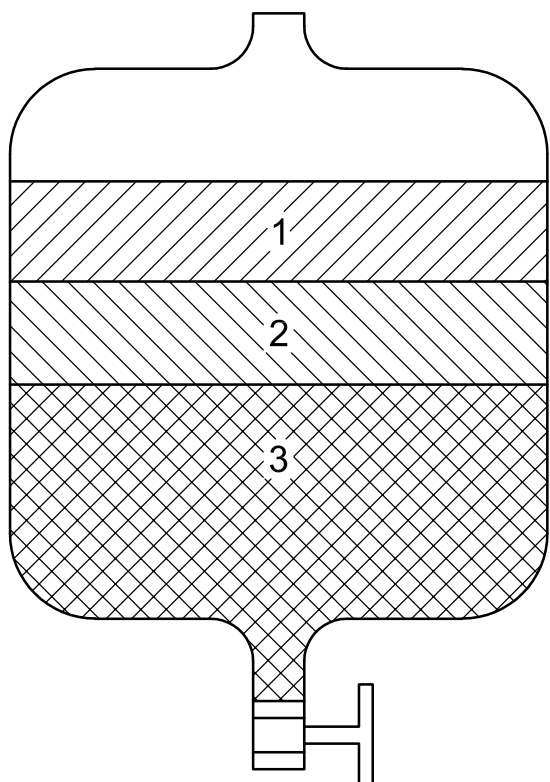
**Key**

- | | |
|----------------------|------------------------|
| 1 oil | 3 water |
| 2 oil/water emulsion | 4 oil/solvent solution |

IMPORTANT — Observe manufacturer's safety instructions and ensure that collection columns are compatible with the solvent.

Figure 5 — Oil/water separator

Figure 6 — Oil-solvent/water separator

Drain the heavier oil/solvent solution and measure the actual quantity of oil collected by subtracting the measured quantity of solvent from the total.

It is not necessary to expose the test-collection columns to solvent; if a series of measurements is made, the amount of sample remaining in the collection columns is a constant, so material is lost only from the first result.

NOTE Information on the measurement of the water content in an oil emulsion can be found in the Reference [2].

8.2.5 Air flow-rate (discharge)

The air flow-rate measurement should have an accuracy of better than 5 % of the actual flow.

8.2.6 Temperature

The temperature is measured in degrees Celsius with an accuracy of better than 1 °C.

8.3 Calculation of test results

8.3.1 General

The accuracy of the test is dependant on the volume of oil collected and increases with increasing volume of oil. It is necessary to ensure that results are stable, repeatable and presented in a form that shows that this has been achieved.

8.3.2 Oil content

When the volume of the collected oil is measured, the oil content, X , in milligrams oil per cubic metre air, is calculated using Equation (1):

$$X = \frac{V \times \rho}{q \times H \times 3,6} \quad (1)$$

where

V is the volume of oil collected, expressed in millilitres;

ρ is the specific density of the oil, expressed in kilograms per cubic metre;

q is the air flow-rate, expressed in litres per second at reference conditions; see Clause 5;

H is the duration of the test, expressed in hours.

When the mass of the collected oil is measured, the oil content, X , is calculated using Equation (2):

$$X = \frac{m}{q \times H \times 3,6} \quad (2)$$

where m is the mass of oil, expressed in milligrams.

8.4 Presentation of results

Data to be recorded and their form of presentation are shown in Annex A.

9 Test procedures — Method B

9.1 Oil vapour

To prevent condensation of oil vapour, isothermal conditions should be maintained between the main stream and the sample stream for the period of the test.

9.2 Maximum air velocity

The velocity of the air through the membrane shall not exceed 1 m/s at operating pressure.

The pressure applied during the test procedure should not exceed the pressure capacity of the membrane holder.

9.3 Temperature

The temperature is measured in degrees Celsius with accuracy better than 1 °C.

9.4 Handling

Clean membranes shall be stored such that they are protected against dust and atmospheric contamination. The use of a pair of tweezers is recommended when the membrane is placed in and taken out of the membrane holder. After the measurement is completed and before analysis, the exposed membrane shall be stored and protected from dust. A clean glass petri dish is most suitable. Do not store the membrane in containers made from organic or hydrocarbon materials. If several hours elapse between measuring and analysis, the membrane should be stored in a cool place.

9.5 Blank sample

In order to check that the membranes are clean, choose a new membrane at random. Analyse this membrane to make sure that it does not contain oil.

9.6 Preparation

Ensure there is no hydrocarbon contamination of the membrane holder or components caused by degreasing procedures. Once the holder has been cleaned, handle it only using polyethylene gloves to protect from finger-borne grease contamination. Using tweezers, pre-load the holder with three layers of suitable sampling discs (see Clause B.3) and insert a suitable seal on the inlet flow side of the outside diameter of the sampling disc to provide an integral seal.

The chamber may then be suitably clamped externally to allow pressurization to system pressure. Mount the holder in the test pipe as shown schematically in Figure B.3.

The test equipment shall be completely free from oil, hydrocarbons and other contaminants before it is connected to the system. This is particularly important for the parts between the connection point and the membrane holder, which should be very carefully cleaned. Bends are not permitted within a distance of ten pipe diameters from the measuring equipment.

The assembly should not contribute any hydrocarbon background of its own; checks to establish this can be performed by analysis of the solvent used to cleanse the assembly prior to use.

9.7 Test method B1

9.7.1 Where the concentration of oil aerosol is unknown, an initial test can be carried out to establish the approximate level.

9.7.2 The aerosol oil content is measured by means of a collection membrane (see Figure 2 and 7.2.1.1), which is placed in the membrane holder. Before inserting the membrane, divert the air through the bypass tube as follows.

- a) Turn full-flow ball valve in the bypass pipe (key item 4c, Figure 2) to the open position.
- b) Shut valves (key items 4a, and 4b, Figure 2).
- c) Evacuate the membrane holder by means of the valve (key item 6, Figure 2). The air flow is now diverted through the bypass tube (key item 10, Figure 2).
- d) Open the membrane holder and place three layers of membrane and a supporting disc in the holder (the disc shall be placed after the membrane; see also Figure B.3).
- e) Shut valve (key item 6, Figure 2) and insert the membrane holder.

9.7.3 The aerosol measuring device is now ready and is used in the following way.

- a) Open valve (key item 4a, Figure 2) carefully, so that the membrane holder is pressurized.
- b) Turn valve (key item 4b, Figure 2) to the open position and carefully close valve (key item 4c, Figure 2), the flow control valve (key item 7, Figure 2) having been pre-set to provide the required flow through the sampling membrane. To calculate the maximum flow rate through the membrane so that the velocity of 1 m/s is not exceeded, see 7.2.1.
- c) Measure the time required for collection, which should be at least 2 min, stop the test by opening valve (key item 4c, Figure 2) and closing valve (key item 4b, Figure 2).
- d) Shut valve (key item 4a, Figure 2) and evacuate the membrane holder using valve (key item 6, Figure 2).
- e) Take out the membrane, place it in a hydrocarbon-free container and protect it from contaminants.

For methods of analysis and calculation of the amount of oil present, see Clause 11.

9.8 Test method B2

9.8.1 Selection of probe

The air flow shall be sampled and tested using the method described in Annex B.2.

10 Analytical procedure for methods B1 and B2

10.1 Principle

The oil collected on the membrane or membrane holder is dissolved in a suitable optical-grade solvent and the amount determined by infrared spectrometry (see Figure 7).

The concentration of oil in solution is proportional to the absorbance of infrared (IR) light at three wave numbers characteristic for oil. These are normally $2\,960\text{ cm}^{-1}$, $2\,925\text{ cm}^{-1}$ and $2\,860\text{ cm}^{-1}$, but they are dependant on the type of oil.

The absorbance, A , a dimensionless ratio, is calculated as given in Equation (3):

$$A = \lg \left(\frac{I_0^3}{I_1 I_2 I_3} \right) \quad (3)$$

where

I_0 is the baseline light intensity (solvent);

I_1, I_2, I_3 are the light intensities at the three characteristic wave numbers (solution).

The absorbance is then compared with the graph of absorbencies calculated similarly for solutions of known concentration.

If more than three peaks are present in the spectrum of interest, then the same three peaks used during calibration should be employed in the analysis.

10.2 Solvent

For the purpose of oil extraction from the membranes and holder, a solvent shall be chosen that has a good solvency for the oil in question, contains no C-H bonds in its chemical composition and has an optical transparency at the infrared wave numbers in the range of $3\,400\text{ cm}^{-1}$ to $2\,500\text{ cm}^{-1}$. The reagents should be handled with care and in accordance with manufacturer or supplier instructions. The solvents chosen should be specifically prepared for use in infrared spectroscopy.

10.3 Apparatus

10.3.1 Infrared spectrometer

Double-beam or Fourier-transform infrared spectrometer covering a wave number range of at least $3\,400\text{ cm}^{-1}$ to $2\,500\text{ cm}^{-1}$ and with a transmittance reproducibility of better than 0,3 %.

10.4 Procedure — Analysis of oil collected by the membrane

Wash the membrane to ensure that there is no trace of oil present on the membrane.

Record the spectrum from $3\,400\text{ cm}^{-1}$ to $2\,500\text{ cm}^{-1}$.

NOTE A typical IR spectrum is shown in Figure 7.

Determine the amount of oil collected by the membrane using the calibration graph obtained (see 11.1 and Figure 8).

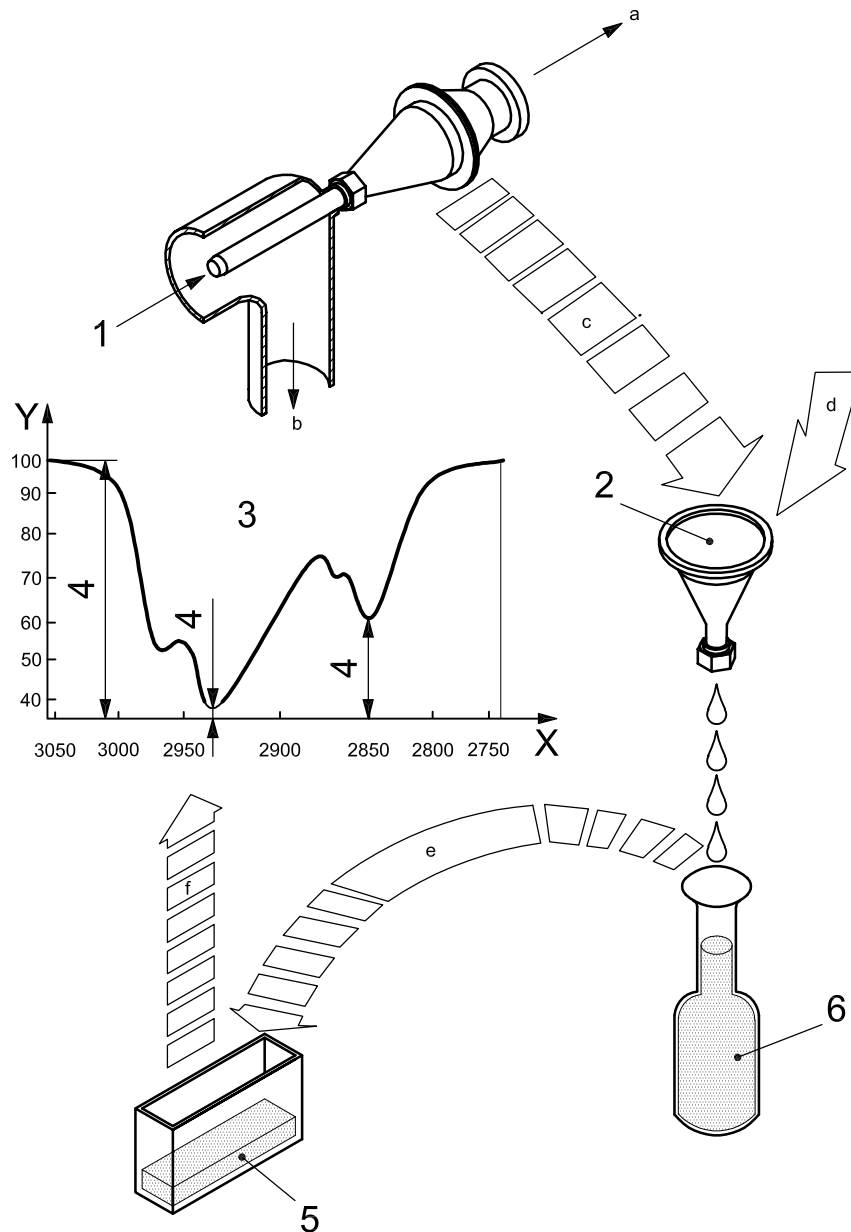

Key

- 1 isokinetic probe
- 2 membrane
- 3 typical infrared spectrum
- X wave number, expressed in reciprocal centimetres
- Y transmittance, expressed in percent
- 4 wave numbers for the three absorbance bands
- 5 infrared spectrometer cell
- 6 oil plus solvent
- a To flow meter and control valve.
- b To main flow meter.
- c Remove membrane holder and membrane.
- d Add solvent; see 10.2.
- e Fill cell with sample.
- f To infrared spectrometer.

Figure 7 — Analytical test method

11 Test result processing

11.1 Preparation of the calibration graph

Using an analytical balance or other precision weighing instrument with a resolution of no less than 0,1 mg, weigh out 100 mg of the oil under investigation and dilute it to a volume of 100 ml with clean solvent to give a stock solution with an oil concentration of 1 mg/ml.

From this initial stock solution, prepare several calibration samples that span the expected range of oil concentrations. Calibration samples should be prepared by measuring a prescribed volume of the initial solution and diluting it with clean solvent to a volume of 50 ml. Prescribed volumes of the initial stock solution and the resulting oil concentrations of the diluted calibration samples are shown in Table 3.

Table 3 — Dilution of the standard solution

Volume of initial stock solution ml	Oil concentration of the diluted calibration sample µg/ml
0,1	2
0,5	10
1,0	20
2,0	40
3,5	70
5,0	100

It should be noted that the resulting concentrations shown in Table 3 assume that the mass of oil measured is exactly 100 mg. In practice, this is unlikely and resulting concentrations should be calculated based on the actual mass of the oil weighed out.

For each calibration sample, record a spectrum and calculate the absorbance in accordance with 10.1. Using the results, construct a calibration curve by plotting absorbance against oil concentration, as shown in Figure 8.

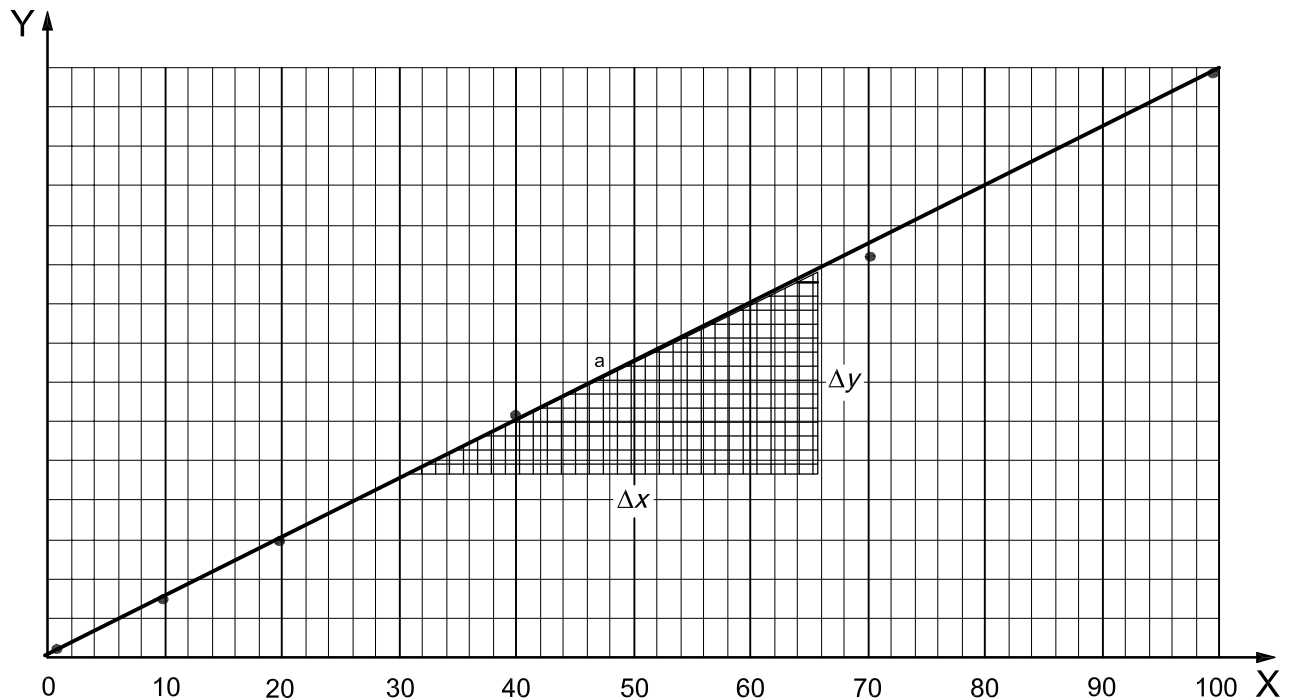
**Key**

X oil concentration, expressed in micrograms per millilitre

Y absorbance, A , equal to $\lg\left(I_0^3/I_1I_2I_3\right)$

^a The calibration coefficient, C , is equal to the slope, m , which is also equal to Δy divided by Δx .

Figure 8 — Calibration curve

A straight line of the form

$$y = mx + c$$

shall be constructed through the data set and which intersects the x axis at c (in this case, the origin $c = 0$).

where

m is the slope of the curve, equal to Δy divided by Δx ;

c is the x axis intercept of the curve, in this case, the origin; the absorbance equals 0 when the oil concentration is 0.

A linear least-squares regression shall be used to construct the best-fitting straight line. The computed accuracy, as indicated by the coefficient of determination, R^2 , shall be no less than 0,995; otherwise, the analysis shall be repeated. The resulting calibration coefficient, C , is determined from the slope, m , of the curve.

The calibration curve varies according to the degree of oxidation the oil has undergone. Where possible, therefore, use oils of known origin taken from the compressor or other known source at the time of test to prepare the calibration graph.

The calibration curve is valid only for the specific oil analysed. A separate calibration curve shall be constructed for each different oil and also for each different manufacturing batch of the same oil.

NOTE The R^2 value represents the deviations of the data points from the straight line and indicates how well the data fit this line; when multiplied by 100, the R^2 value gives a percentage degree of fit, in this case to a straight line.

11.2 Calculation of test results

11.2.1 General

The length of the oil collection-times are based on the time required to accumulate enough oil such that the solvent extraction of the oil from the membranes results in solutions with a range of oil concentrations of 2 µg/ml to 100 µg/ml. Since, when commencing the test, the concentration of oil in the compressed air and, subsequently, the rate of collection on the membranes is unknown, several tests can be required to establish a suitable test time. It is recommended that the test times be kept short initially to prevent gross contamination levels building up on the pipework and fittings of the test equipment.

11.2.2 Oil content

The oil content, X , expressed in milligrams per cubic metre air, is calculated using Equation (6):

$$X = \frac{A \times V_s}{C \times q \times H \times 3\,600} \quad (6)$$

where

A is the absorbance, as calculated in 10.1;

V_s is the volume of oil and solvent collected after solvent extraction of the membranes and holder, expressed in millilitres;

C is the calibration coefficient, as determined from the slope, m , of the calibration curve in 11.1;

q is the air flow-rate, expressed in litres per second at reference conditions; see Clause 5;

H is the duration of the test, expressed in hours.

12 Uncertainty of the method

Using the test apparatus as described for methods B1 and B2, the uncertainty of the method is better than $\pm 10\%$ of the measured value and the range is from 0,001 mg/m³ to 10 mg/m³ with free-air volume and sampling times from 10 h to 2 min, respectively.

Annex A (informative)

Typical test report

When measured under the conditions mentioned below, the compressed air sample, analysed according to method (A, B1 or B2) has been found to contain mg/m³ of oil in liquid or aerosol form.

Conditions:

The sample was taken from (e.g. receiver, main pipe, branch pipe, etc.).

At the sampling point, the following conditions prevailed:

Pressure:	kPa [bar (e)]
Temperature:	°C
Estimated flow rate:	l/s

The compressed-air system had the following configuration (specify if appropriate)

Equipment
Piping
Load condition

Compressor 1 was running at	% load
Compressor 2 was running at	% load
Compressor 3 was running at	% load
Compressor <i>n</i> was running at	% load

Annex B (informative)

Typical equipment layout and dimensional details

B.1 Method B1

The general arrangement of the test equipment at the point of measurement is shown in Figure B.1. The membrane holder shown is that for which a design is included in Clause B.3. The type of holder may actually be any commercially available type which utilizes the same circular membrane as in the holder (key item 5).

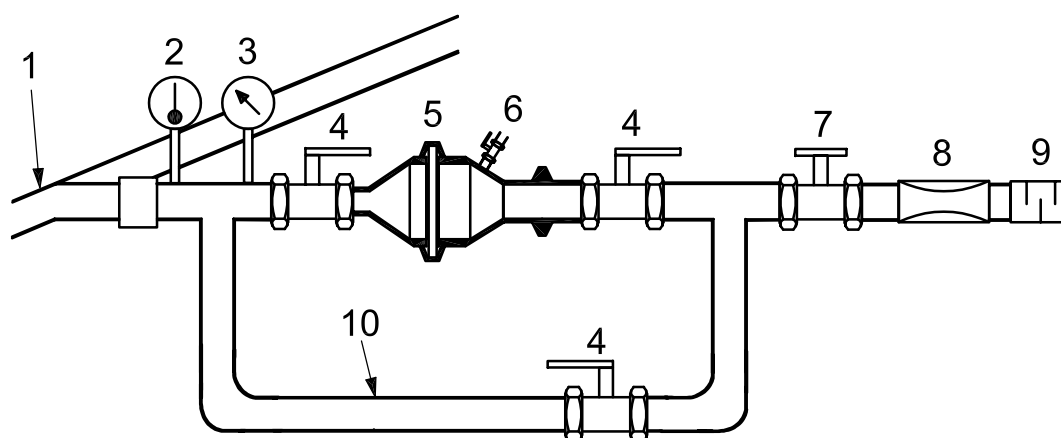

Key

- | | |
|---------------------------------|--|
| 1 compressed-air sampling point | 6 membrane-holder depressurising valve |
| 2 temperature sensing/measuring | 7 multi-turn flow-control valve |
| 3 pressure sensing/measuring | 8 flow sensing/measuring |
| 4 full-flow ball valve | 9 silencer |
| 5 membrane holder | 10 bypass pipe |

Figure B.1 — Typical test equipment for method B1

B.2 Method B2

B.2.1 Isokinetic sampling — General

The probe and membrane holder should be conditioned to be at the same temperature as the test air, otherwise condensation can occur.

Isokinetic sampling devices should exhibit the following characteristics.

- The probe should be a minimum distance of ten pipe diameters from upstream bends or restrictions and three diameters from downstream bends or restrictions.
- The size of the probe should not influence the air stream. The nozzles may vary in shape and construction.
- Precautions are necessary to prevent surface condensation of oil vapours unless the internal surfaces are washed with solvent.
- Turbulent flow conditions within the main air stream are required for sampling (Reynolds number greater than 4 000).

In normal industrial use, compressed air is in a state of turbulent flow, which occurs when the flow, q , expressed in litres per second at actual conditions, in the pipe meets the condition in Equation (B.1):

$$q > D/20 \quad (\text{B.1})$$

where D is the pipe bore, expressed in millimetres.

B.2.2 Equipment set-up for isokinetic sampling

The set-up for the isokinetic sampling probe at the insertion point of the compressed air system under investigation is shown in Figure B.2.

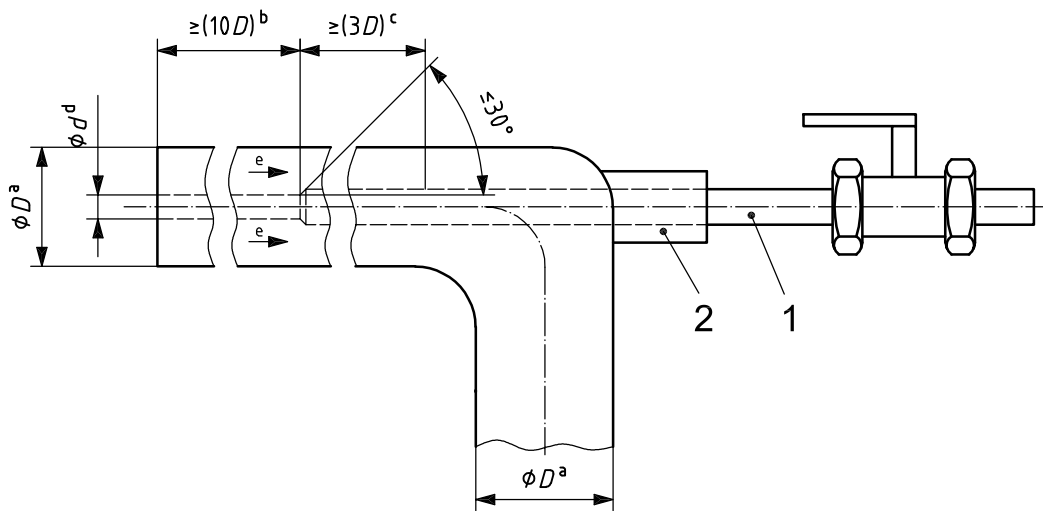

Key

- | | | | |
|---|---|---|---|
| 1 | sampling probe in the main pipe | c | probe insertion point at minimum of $\geq 3 \times D$ |
| 2 | adjustable gland to allow adjustment of probe | d | internal probe diameter, d_{in} |
| a | main pipe inside diameter, D | e | direction of air flow |
| b | minimum straight length in front of probe, $\geq 10 \times D$ | | |

Figure B.2 — Set-up of probe insertion for isokinetic sampling

For sampling from high-flow systems, isokinetic sampling may be used when wall-flow is not present.

The test set-up for isokinetic sampling is comprised of elements as shown in Figure B.3. The valve (key item 5) and flow meter (key item 6) allow adjustment and measurement of sample flow, respectively.

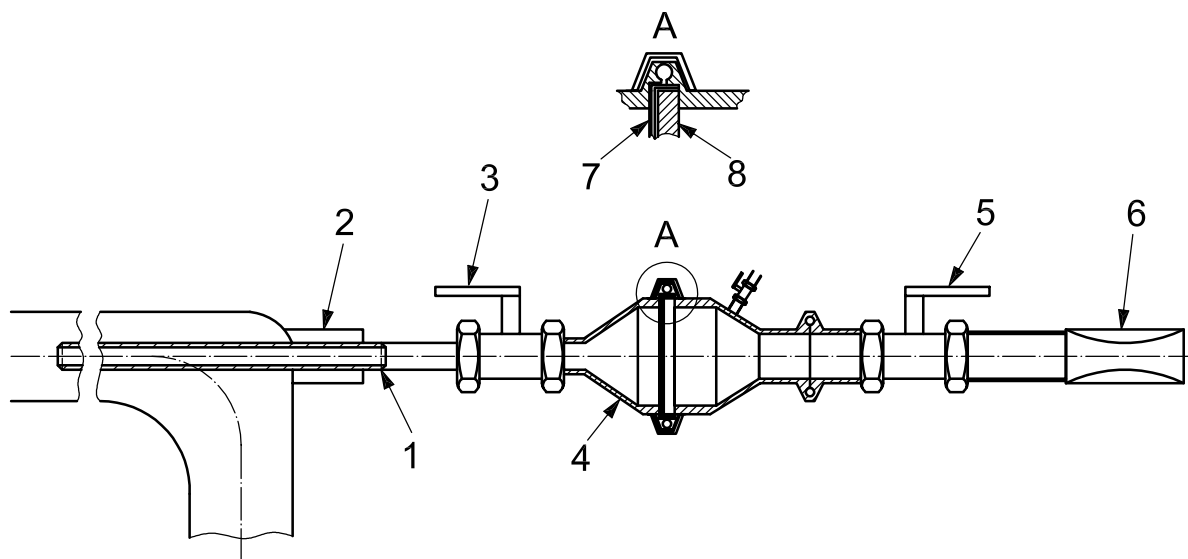

Key

- 1 probe
- 2 nozzle with gland
- 3 full-flow ball valve
- 4 membrane holder
- 5 multi-turn flow control valve
- 6 flow sensing/measuring
- 7 three membrane layers
- 8 stainless steel support disc (thickness 3 mm)

Figure B.3 — Equipment set-up for method B2, isokinetic sampling
(shown for bend insertion of probe)

B.3 Design of membrane holder

Figure B.4 provides guidance on the dimensioning of the various elements used in the construction of the membrane holder. The design shown in Figure B.4 facilitates the use of a 55 mm membrane.

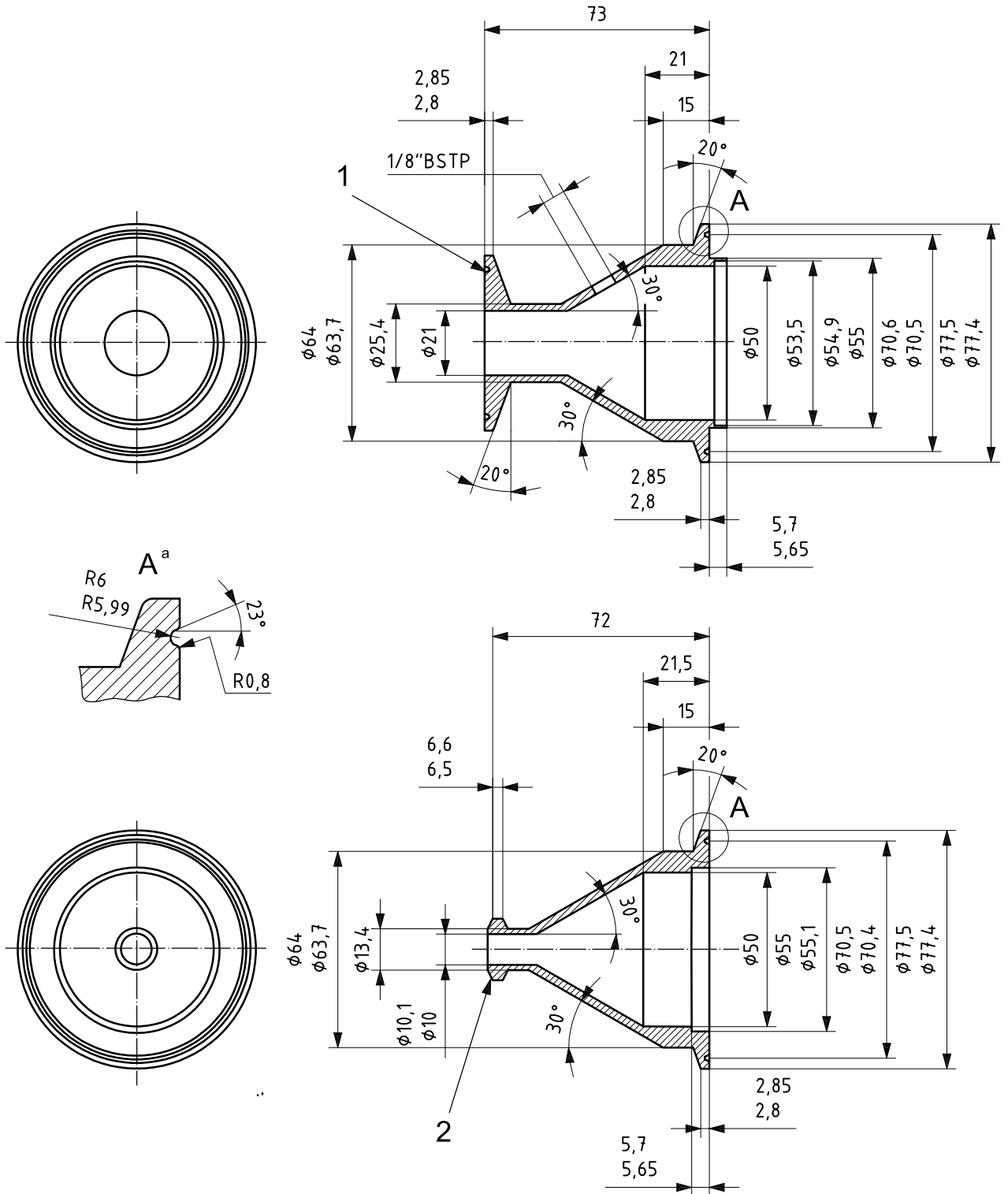

Key

- 1 typical crevice-free joint
- 2 crevice-free dairy joint to suit probe
- a Typical crevice-free joint.

Figure B.4 — Typical membrane holder

B.4 Design of the isokinetic probe

The general construction of the probe is shown in Figure B.5 and is intended for use at reference conditions at 700 kPa (7 bar) and a velocity of 0,16 m/s when used with a suitable membrane holder designed for a 55 mm diameter standard disc.

The probe should be of circular cross-section, the open end having a thickness of less than 1,5 mm and the internal and external surfaces having an inclination not greater than 30° to the axis of the nozzle; see Figure B.5.

The angle at the nozzle minimizes the effect of impact onto the end of the probe.

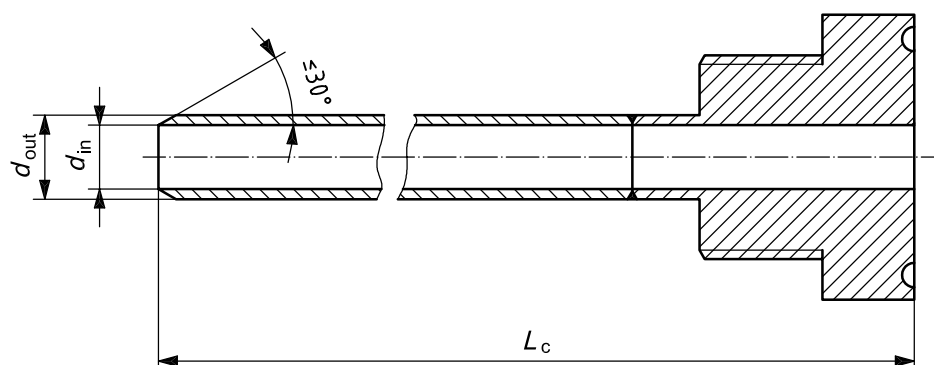

Typical probe sizes	d_{in}	d_{out}	L_c
1	7	9,6	200
2	10	12,6	200
3	17	19,6	400

Figure B.5 — Typical isokinetic sampling probes

B.5 Probe installation

An isokinetic sampling probe should not create a problem, providing the general design in Figure B.5 is followed. A simple compression seal may be used, provided a fluorocarbon elastomer (or similar) seal is used to prevent contamination during the analysis procedure.

This seal shall be capable of maintaining the probe in the pipe up to the maximum working pressure. Ideally this gland should allow insertion of the probe to differing lengths if necessary.

Bibliography

- [1] ALLEN, T. Particle size measurement, Chapman and Hall, Third Edition, 1981. ISBN 0412154102 (British Library)¹⁾
- [2] ASTM D 3921-96(2003)e1²⁾, *Standard Test Method for Oil and Grease and Petroleum Hydrocarbons in Water*
- [3] ISO 1000, *SI units and recommendations for the use of their multiples and of certain other units*

1) The British Library, St Pancras, 96 Euston Road, London, NW1 2DB, Phone: +44 (0)870 444 1500, UK, website: <http://www.bl.uk/index.shtml>.

2) ASTM International, 100 Barr Harbor Drive, PO Box C700, West Conshohocken, PA, 19428-2959 USA Phone: (610) 832-9585, Fax: (610) 832-9555, website: <http://www.astm.org>.

BSI — British Standards Institution

BSI is the independent national body responsible for preparing British Standards. It presents the UK view on standards in Europe and at the international level. It is incorporated by Royal Charter.

Revisions

British Standards are updated by amendment or revision. Users of British Standards should make sure that they possess the latest amendments or editions.

It is the constant aim of BSI to improve the quality of our products and services. We would be grateful if anyone finding an inaccuracy or ambiguity while using this British Standard would inform the Secretary of the technical committee responsible, the identity of which can be found on the inside front cover.
Tel: +44 (0)20 8996 9000. Fax: +44 (0)20 8996 7400.

BSI offers members an individual updating service called PLUS which ensures that subscribers automatically receive the latest editions of standards.

Buying standards

Orders for all BSI, international and foreign standards publications should be addressed to Customer Services. Tel: +44 (0)20 8996 9001.
Fax: +44 (0)20 8996 7001. Email: orders@bsi-global.com. Standards are also available from the BSI website at <http://www.bsi-global.com>.

In response to orders for international standards, it is BSI policy to supply the BSI implementation of those that have been published as British Standards, unless otherwise requested.

Information on standards

BSI provides a wide range of information on national, European and international standards through its Library and its Technical Help to Exporters Service. Various BSI electronic information services are also available which give details on all its products and services. Contact the Information Centre.
Tel: +44 (0)20 8996 7111. Fax: +44 (0)20 8996 7048. Email: info@bsi-global.com.

Subscribing members of BSI are kept up to date with standards developments and receive substantial discounts on the purchase price of standards. For details of these and other benefits contact Membership Administration.
Tel: +44 (0)20 8996 7002. Fax: +44 (0)20 8996 7001.
Email: membership@bsi-global.com.

Information regarding online access to British Standards via British Standards Online can be found at <http://www.bsi-global.com/bsonline>.

Further information about BSI is available on the BSI website at <http://www.bsi-global.com>.

Copyright

Copyright subsists in all BSI publications. BSI also holds the copyright, in the UK, of the publications of the international standardization bodies. Except as permitted under the Copyright, Designs and Patents Act 1988 no extract may be reproduced, stored in a retrieval system or transmitted in any form or by any means – electronic, photocopying, recording or otherwise – without prior written permission from BSI.

This does not preclude the free use, in the course of implementing the standard, of necessary details such as symbols, and size, type or grade designations. If these details are to be used for any other purpose than implementation then the prior written permission of BSI must be obtained.

Details and advice can be obtained from the Copyright & Licensing Manager.
Tel: +44 (0)20 8996 7070. Fax: +44 (0)20 8996 7553.
Email: copyright@bsi-global.com.