



BSI Standards Publication

Reciprocating internal combustion engine driven alternating current generating sets

Part 9: Measurement and evaluation of mechanical vibrations

National foreword

This British Standard is the UK implementation of ISO 8528-9:2017. It supersedes BS 7698-9:1996, which is withdrawn.

The UK participation in its preparation was entrusted to Technical Committee MCE/14, RIC engines.

A list of organizations represented on this committee can be obtained on request to its secretary.

This publication does not purport to include all the necessary provisions of a contract. Users are responsible for its correct application.

© The British Standards Institution 2017
Published by BSI Standards Limited 2017

ISBN 978 0 580 85456 9

ICS 29.160.40; 17.160; 27.020

Compliance with a British Standard cannot confer immunity from legal obligations.

This British Standard was published under the authority of the Standards Policy and Strategy Committee on 31 July 2017.

Amendments/corrigenda issued since publication

Date	Text affected
------	---------------

INTERNATIONAL
STANDARD

ISO
8528-9

Second edition
2017-07

**Reciprocating internal combustion
engine driven alternating current
generating sets —**

Part 9:
**Measurement and evaluation of
mechanical vibrations**

*Groupes électrogènes à courant alternatif entraînés par moteurs
alternatifs à combustion interne —*

Partie 9: Mesurage et évaluation des vibrations mécaniques



Reference number
ISO 8528-9:2017(E)



COPYRIGHT PROTECTED DOCUMENT

© ISO 2017, Published in Switzerland

All rights reserved. Unless otherwise specified, no part of this publication may be reproduced or utilized otherwise in any form or by any means, electronic or mechanical, including photocopying, or posting on the internet or an intranet, without prior written permission. Permission can be requested from either ISO at the address below or ISO's member body in the country of the requester.

ISO copyright office
Ch. de Blandonnet 8 • CP 401
CH-1214 Vernier, Geneva, Switzerland
Tel. +41 22 749 01 11
Fax +41 22 749 09 47
copyright@iso.org
www.iso.org

Contents

	Page
Foreword	iv
1 Scope	1
2 Normative references	1
3 Terms and definitions	1
4 Symbols and abbreviated terms	1
5 Regulations and additional requirements	2
6 Measuring devices	2
7 Location of measuring points and direction of measurements	3
8 Operating conditions during measurement	3
9 Evaluation of results	3
10 Test report	4
Annex A (informative) Typical generating set configurations	5
Annex B (informative) Remarks on the assessment of vibrations of the generating set	8
Annex C (informative) Vibration values	9
Annex D (informative) Measuring report	10
Bibliography	12

Foreword

ISO (the International Organization for Standardization) is a worldwide federation of national standards bodies (ISO member bodies). The work of preparing International Standards is normally carried out through ISO technical committees. Each member body interested in a subject for which a technical committee has been established has the right to be represented on that committee. International organizations, governmental and non-governmental, in liaison with ISO, also take part in the work. ISO collaborates closely with the International Electrotechnical Commission (IEC) on all matters of electrotechnical standardization.

The procedures used to develop this document and those intended for its further maintenance are described in the ISO/IEC Directives, Part 1. In particular the different approval criteria needed for the different types of ISO documents should be noted. This document was drafted in accordance with the editorial rules of the ISO/IEC Directives, Part 2 (see www.iso.org/directives).

Attention is drawn to the possibility that some of the elements of this document may be the subject of patent rights. ISO shall not be held responsible for identifying any or all such patent rights. Details of any patent rights identified during the development of the document will be in the Introduction and/or on the ISO list of patent declarations received (see www.iso.org/patents).

Any trade name used in this document is information given for the convenience of users and does not constitute an endorsement.

For an explanation on the voluntary nature of standards, the meaning of ISO specific terms and expressions related to conformity assessment, as well as information about ISO's adherence to the World Trade Organization (WTO) principles in the Technical Barriers to Trade (TBT) see the following URL: www.iso.org/iso/foreword.html.

This document was prepared by ISO/TC 70, *Internal combustion engines*.

This second edition cancels and replaces the first edition (ISO 8528-9:1995), which has been technically revised.

A list of all parts in the ISO 8528 series can be found on the ISO website

Reciprocating internal combustion engine driven alternating current generating sets —

Part 9: Measurement and evaluation of mechanical vibrations

1 Scope

This document describes a procedure for measuring and evaluating the external mechanical vibration behaviour of generating sets at the measuring points stated in this document.

It applies to RIC engine driven a.c. generating sets for fixed and mobile installations with rigid and/or resilient mountings. It is applicable for land and marine use, excluding generating sets used on aircraft or those used to propel land vehicles and locomotives.

For some specific applications (essential hospital supplies, high rise buildings, etc.) supplementary requirements may be necessary. The provisions of this document are intended to be regarded as a basis for such applications.

For generating sets driven by other reciprocating-type prime movers (e.g. sewage gas engines, steam engines), the provisions of this document are intended to be regarded as a basis for such applications.

2 Normative references

The following documents are referred to in the text in such a way that some or all of their content constitutes requirements of this document. For dated references, only the edition cited applies. For undated references, the latest edition of the referenced document (including any amendments) applies.

ISO 2041, *Mechanical vibration, shock and condition monitoring — Vocabulary*

ISO 8528-5:2013, *Reciprocating internal combustion engine driven alternating current generating sets — Part 5: Generating sets*

3 Terms and definitions

For the purposes of this document, the terms and definitions given in ISO 2041 and the following apply.

ISO and IEC maintain terminological databases for use in standardization at the following addresses:

— IEC Electropedia: available at <http://www.electropedia.org/>

— ISO Online browsing platform: available at <http://www.iso.org/obp>

3.1

vibration severity

generic term that designates a value or set of values, such as a maximum value, average value or rms value, or other parameter that is descriptive of the vibration

Note 1 to entry: It may refer to instantaneous values or average values.

4 Symbols and abbreviated terms

For the purposes of this document the following symbols apply.

n_r	Declared engine speed
f	Frequency
s	Displacement
t	Time
v	Velocity
w	Angular velocity
x	Axial co-ordinate
y	Transverse co-ordinate
z	Vertical co-ordinate

The following subscripts are used in conjunction with the vibration quantities v and s .

rms	Value of vibration quantity
x	Measured value of vibration quantity in the axial direction
y	Measured value of vibration quantity in the transverse direction
z	Measured value of vibration quantity in the vertical direction
1, 2 ... n	Progressive values

5 Regulations and additional requirements

5.1 For a.c. generating sets used on board ships and offshore installations which are required to comply with rules of a classification society, the additional requirements of the classification society shall be observed. The classification society shall be stated by the customer prior to placing the order.

For a.c. generating sets in unclassified equipment, such additional requirements are in each case subject to agreement between the manufacturer and customer.

5.2 If special requirements from regulations of any other authority, e.g. inspecting and/or legislative authorities, are required to be met, the authority shall be stated by the customer prior to placing the order.

Any further additional requirements shall be subject to agreement between the manufacturer and customer prior to placing the order.

6 Measuring devices

The measuring system shall provide the rms values of displacement and velocity with an accuracy of $\pm 10\%$ over the range 10 Hz to 1 000 Hz and an accuracy of $-20\%/+10\%$ over the range 2 Hz to 10 Hz. These values may be obtained from a single sensor whose signal is either integrated or differentiated, depending on the outcome of the measuring device, to derive the quantities not directly measured, provided the accuracy of the measuring system is not adversely affected.

The accuracy of measurement is also affected by the method of connection between the transducer and the object being measured. Both the frequency response and the measured vibration are affected by the method of attaching the transducer. It is especially important to maintain good attachment between the transducer and the point on the generating set being measured when vibration levels are high.

7 Location of measuring points and direction of measurements

Figure 1 shows the recommended points of vibration measurement in generating sets. The specifications apply as appropriate for other types of design. If possible, measurements shall be taken at these points in the three main directions, defined by x, y and z.

Figure 1 shows the approximate positions of the measuring points which have to be located on the solid engine block and on solid areas of the generator main body in order to avoid measuring local structural vibrations.

If experience with similar sets has shown at which points the maximum vibration severity is to be expected, not all the points given in Figure 1 need necessarily be measured.

The vertical in-line engine shown is given as an example only. Measuring points 1 to 4 are applicable as appropriate for other types of engine, e.g. V-engines, horizontal engines.

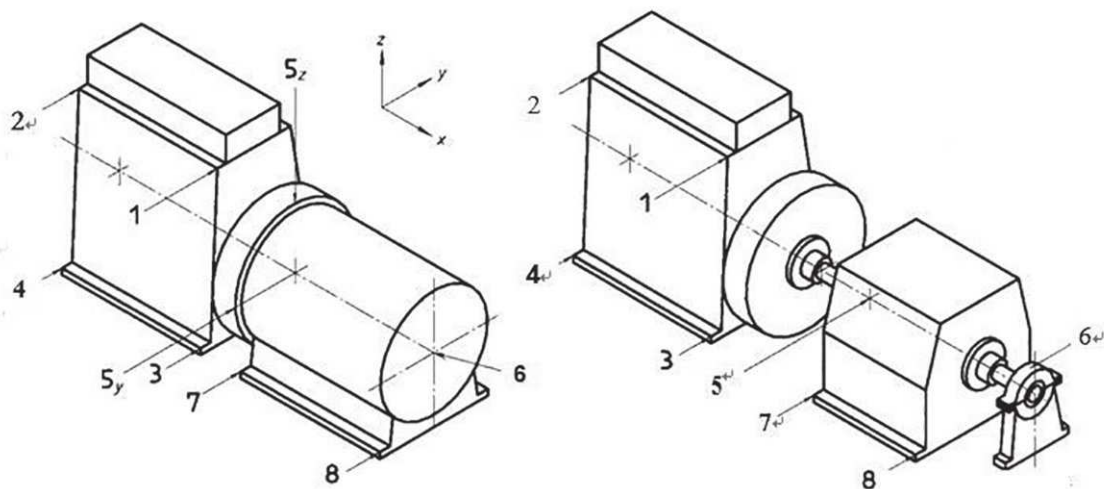

a) Generating set driven by a vertical in-line engine with flange housing coupled generator with integral bearings

b) Generating set driven by a vertical in-line engine and a generator with pedestal bearings

Key

- 1, 2 front end top edge and back end top edge
- 3, 4 front and rear lower edge of engine cylinder block
- 5, 6 generator main bearing housing (5 may also be the flange housing for single bearing machines)
- 7, 8 generator (main body) mounting points

Figure 1 — Arrangement of measuring points

8 Operating conditions during measurement

The measurements shall be taken with the generating set *under steady state conditions* at its operating temperature and rated frequency at rated power. If the rated power of the generating set is not attainable, it should be tested at the maximum power that can be attained.

9 Evaluation of results

The main excitation frequencies of the RIC engine are found in the range 2 Hz to 300 Hz. However, when considering the overall generating set structure and components, a range of 2 Hz to 1 000 Hz is required to evaluate the vibration.

Additional testing may be necessary to ensure that no local structural resonances contribute to the measurement result.

Assessment of the potential effects of vibration are made by reference to [Table C.1](#) which gives rms values of vibration displacement and velocity. These values may be used as guidelines for evaluating the measured vibration levels.

Experience has shown that with a standard design of generating set structure and components, damage would not be expected if vibration levels remain below value 1.

If the vibration levels fall between values 1 and 2, assessment of the generating set structure and components may be required along with an agreement between the generating set manufacturer and the component supplier in order to ensure reliable operation.

In some cases vibration levels can be above value 2 but only if individual special designs of generating set structure and components are applied.

In all cases the generating set manufacturer shall remain responsible for the compatibility between each of the generating set components in accordance with ISO 8528-5:2013.

10 Test report

The indicated measurement results shall include the main data of the generating set and the measuring equipment used. These data can be referenced in [Annex D](#) to make a record.

Annex A (informative)

Typical generating set configurations

There are a number of possibilities for the assembly of a reciprocating internal combustion engine and a generator. [Figures A.1](#) to [A.6](#) show examples of typical configurations.

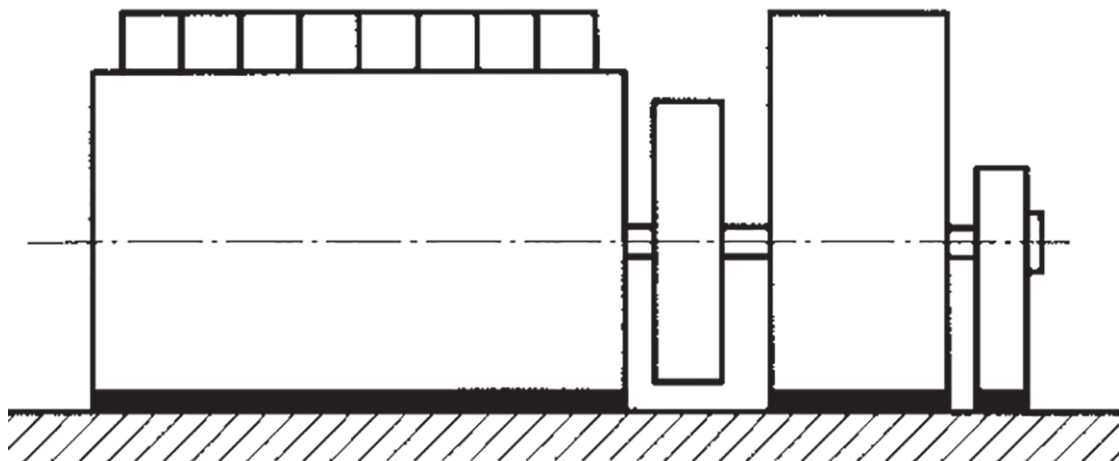

Figure A.1 — Engine and generator rigidly mounted

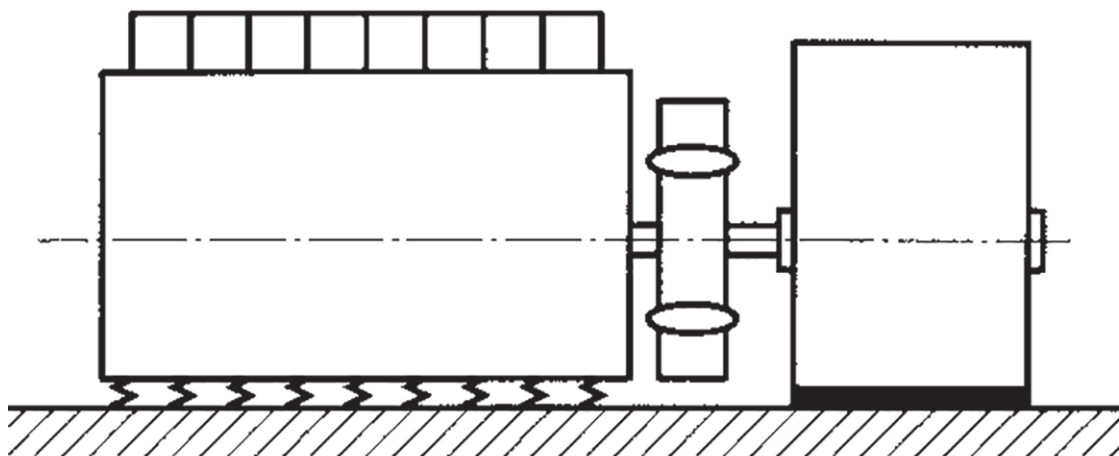

Figure A.2 — Engine resiliently mounted, generator rigidly mounted, flexible coupling

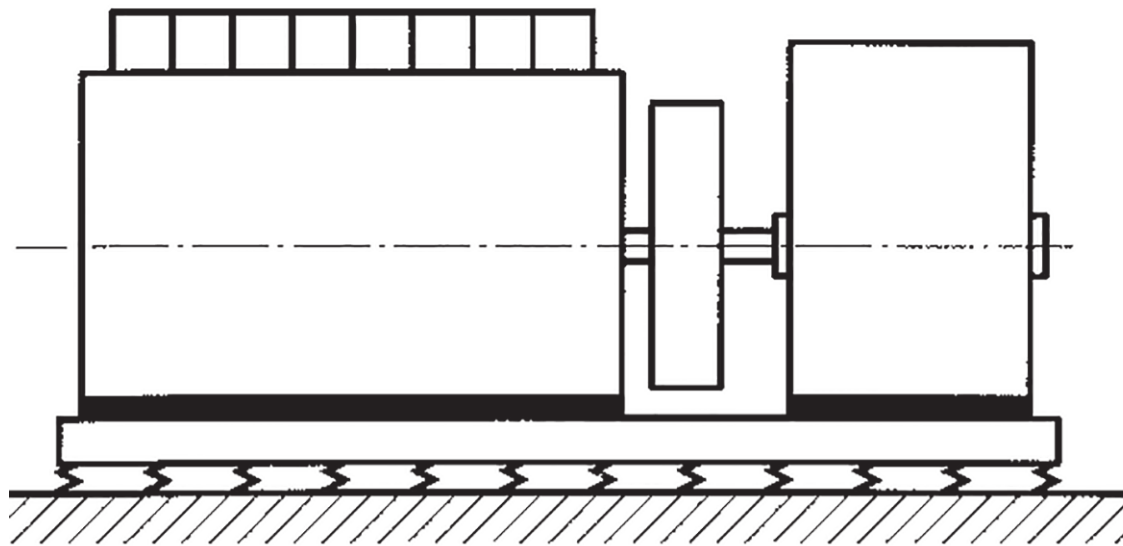

Figure A.3 — Engine and generator rigidly mounted on resiliently mounted base frame

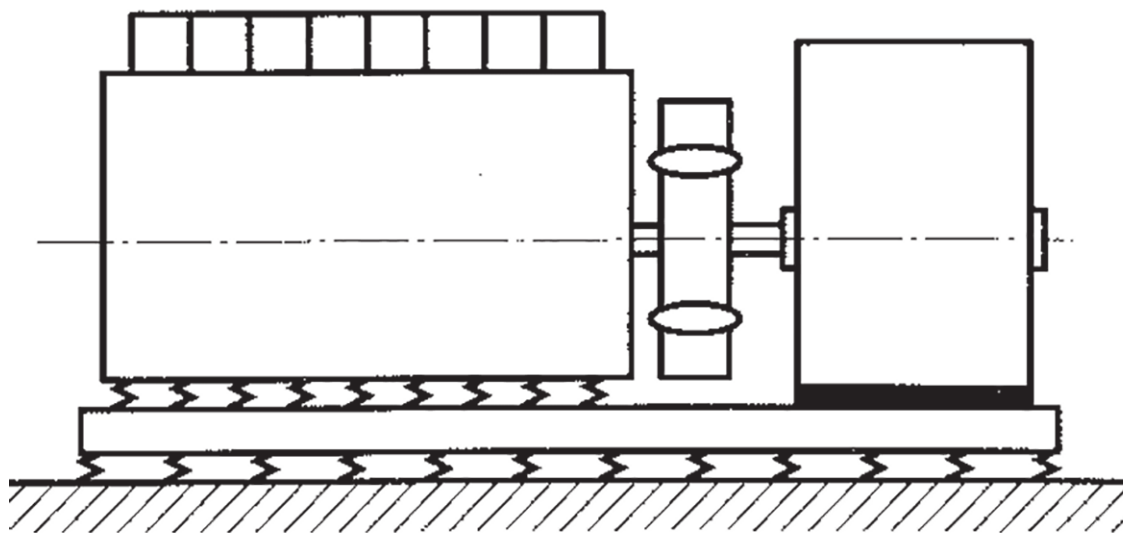

Figure A.4 — Engine resiliently mounted, generator rigidly mounted on resiliently mounted base frame, flexible coupling

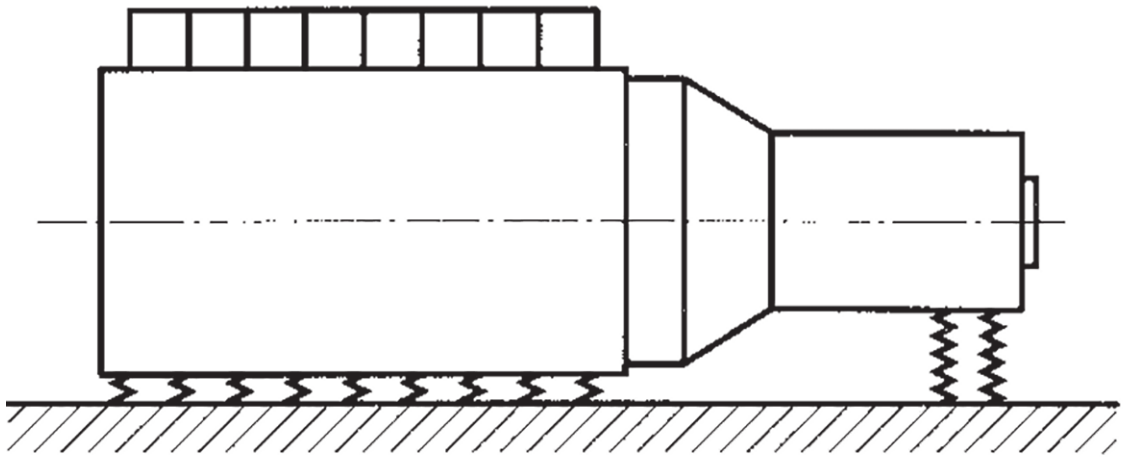

Figure A.5 — Assembly with flange housing and resilient mounting on the engine and generator

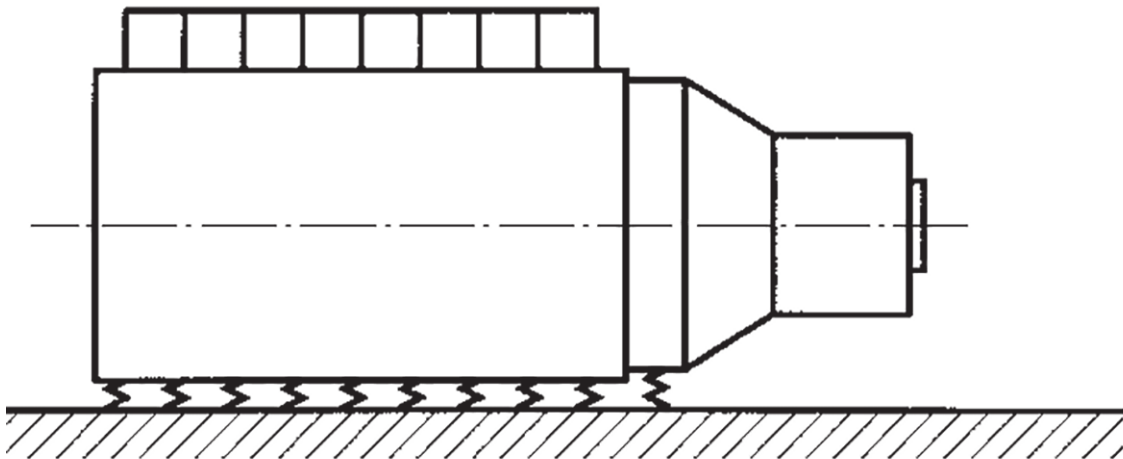

Figure A.6 — Assembly with flange housing and resilient mounting of the engine

Annex B **(informative)**

Remarks on the assessment of vibrations of the generating set

Generators operating in RIC driven generating sets exhibit higher values of vibration severity compared to those driven by rotating prime movers.

Typical features of RIC engines are the oscillating masses, torque fluctuation and pulsating forces in the associated pipe-work. All these features exert considerable alternating forces on the main supports and give rise to high vibration amplitudes on the main frame. The vibration amplitudes are generally higher than those for rotating machinery, but they are largely influenced by the design features of the generating sets.

The vibration values determined by using this document allow us to make a general statement on the vibration behaviour of the generating set and a general assessment of the running behaviour and the vibration interactions of the total set. However, the determined vibration values do not allow us to make a statement on the mechanical stresses of fixed or moving parts of the generating sets.

The determined values of vibration severity do not allow us to make a statement of the torsional and linear vibration behaviour of the shaft system either.

Even if accurate assessment of mechanical stresses in the generating set by using vibration measurement is not possible, experience has shown that the vibration level above which important parts of the generating set are mechanically damaged by undue vibration stress is usually significantly higher than the level which is accepted as “usual” from experience with similar generating sets.

However, if the above “usual” ranges are exceeded, damage to additional attachments and connecting parts of the generating set, as well as to governing and monitoring devices, etc., may occur.

The sensitivity of these components depends on their design and how they are mounted. Thus, in some individual cases, it may be difficult to avoid problems even when the assessment value lies in the “usual” range. Such problems have to be rectified by specific “local measures” on the generating set (e.g. by elimination of mounted component resonances).

Annex C (informative)

Vibration values

[Table C.1](#) shows rms values for displacement and vibration velocity of RIC engine driven a.c. generating sets (frequency range: 2 Hz to 1 000 Hz for displacement, 10 Hz¹⁾ to 1 000 Hz for velocity)

Table C.1

Declared engine speed n_r	Rated power output of the generating set		Vibration displacement ²⁾			Vibration velocity		
			S_{rms} (2 Hz to 1 000 Hz)			v_{rms} (10 Hz to 1 000 Hz)		
min ⁻¹	(cos $\phi = 0,8$) kV·A	kW	RIC engine ³⁾⁴⁾ mm	Generator ³⁾		RIC engine ^{3) 4)} mm/s	Generator ³⁾	
				value 1 mm	value 2 mm		value 1 mm/s	value 2 mm/s
2 000 $\leq n_r \leq 3\ 600$	≤ 15 (1-cylinder engine)	≤ 12 (1-cylinder engine)	—	1,11	1,27	—	70	80
	≤ 50	≤ 40	—	0,8	0,95	—	50	60
	> 50	> 40	—	0,64 ⁵⁾	0,8 ⁵⁾	—	40 ⁵⁾	50 ⁵⁾
1 300 $\leq n_r$ < 2 000	≤ 10	≤ 8	—	—	—	—	-	—
	> 10 but ≤ 50	> 8 but ≤ 40	—	0,64	—	—	40	—
	> 50 but ≤ 125	> 40 but ≤ 100	—	0,4	0,48	—	25	30
	> 125 but ≤ 250	> 100 but ≤ 200	—	0,4	0,48	45	25	30
	> 250	> 200	0,72	0,32	0,45	45	20	28
720 $\leq n_r$ < 1 300	≥ 250 but $\leq 1\ 250$	≥ 200 but $\leq 1\ 000$	0,72	0,32	0,39	45	20	24
	$> 1\ 250$	$> 1\ 000$	0,72	0,29	0,35		18	22
$n_r \leq 720$	$> 1\ 250$	$> 1\ 000$	0,72	0,24 (0,16) ⁶⁾	0,24 (0,24) ⁶⁾		15 (10) ⁶⁾	20 (15) ⁶⁾

1) At least 0,5 th order/ 10 Hz due to disturbance effects of acceleration sensors.

2) S_{rms} is determined from the following equations by using the values given in the table for v_{rms} .

$$S_{rms} = 0,0159 \times v_{rms} \text{ (at 10 HZ)}$$

3) In the case of flange housing coupled generating sets the values measured at point 5 [see [Figure 1 a\)](#)] shall meet the values for generators.

4) The stated values for RIC engines are applicable for engines with power outputs of more than 100 kW. For smaller engines with power outputs below 100 kW, no typical values exist.

5) These values are subject to agreement between the manufacturer and customer.

6) The values given in parentheses are applied to generators mounted on solid concrete foundations. In these cases the axial measurement for points 7 and 8 in [Figure 1 a\)](#) and b) shall be 50 % of the values given in parentheses.

Annex D (informative)

Measuring report

D.1 General data

Company responsible for the measurement:	Customer/User:
Report No.:	Place of measurement:
Date:	Operator:

Table D.1 — Data of the RIC engine and generator to be measured

	RIC engine	Generator
Manufacturer		
Type		
Manufacturing No.		
Declared or rated powerkW kVA cosØ =
Declared or rated speed		
Declared or rated frequencymin ⁻¹min ⁻¹
Construction design	<input type="checkbox"/> In-line engine <input type="checkbox"/> V-engine	<input type="checkbox"/> IMB 20 ¹⁾ <input type="checkbox"/> IMB 520 <input type="checkbox"/> IMB 16 <input type="checkbox"/> Others: <input type="checkbox"/> IMB 3
Number of	Cylinders:	Bearings:
Operating system	<input type="checkbox"/> Two-stroke <input type="checkbox"/> Four-stroke	<input type="checkbox"/> Synchronous <input type="checkbox"/> Asynchronous
Coupling arrangement	<input type="checkbox"/> Flexible plate coupling <input type="checkbox"/> Direct coupling <input type="checkbox"/> Elastic coupling	
1) Abbreviation for type of construction and mounting of generators according to IEC 60034-7, code I.		

D.2 Data of configuration

Foundation drawing

No.:

Company responsible:

Types of configuration

Engine	Generator	Foundation	Base frame (if applicable)	Flange housing
<input type="checkbox"/> rigid	<input type="checkbox"/> rigid	<input type="checkbox"/> rigid	<input type="checkbox"/> rigid	<input type="checkbox"/> yes
<input type="checkbox"/> resilient	<input type="checkbox"/> resilient	<input type="checkbox"/> resilient	<input type="checkbox"/> resilient	<input type="checkbox"/> no

D.3 Measuring positions

The measuring positions and their numbering conform to those shown above [Figure 1](#). Additional measuring positions should be numbered continually and shall be marked on a drawing. It is recommended that all measuring positions be inserted in a detailed drawing.

D.4 Measurement results

Data records, diagrams and spectra, when applicable and required, shall be attached.

Table D.2 — Measurement equipment

Component	Manufacturer	Type	Remarks
Sensor			
Measuring indicator set			
Recording instruments			
Calibration apparatus			

NOTE Terms are according to ISO 2954.

Table D.3 — Particulars of measuring equipment

Mechanical connection	<input type="checkbox"/> screwed <input type="checkbox"/> hand held <input type="checkbox"/> cemented <input type="checkbox"/> magnetic		
Measured value	<input type="checkbox"/> displacement <input type="checkbox"/> velocity <input type="checkbox"/> acceleration		
Recorded value	<input type="checkbox"/> displacement <input type="checkbox"/> velocity <input type="checkbox"/> acceleration		
Measuring range	amplitude:	frequency:	
Frequency analyzer/filter	linear range:	pass-band: ...	
Data for evaluation of measuring records (e.g. amplification, rate of feed):			
Remarks:			

Table D.4 — Measurement results

Power:kW	Ambient temperature: °C						
Speed: min ⁻¹	Type of fuel:						
Measuring point No.	rms overall values (2 Hz to 1 000 Hz) ¹⁾						Remarks
	Direction of measurement						
	axial (x)		transverse (y)		vertical (z)		
	s	v	s	v	s	v	
	mm	mm/s	mm	mm/s	mm	mm/s	
1) Either measured or calculated.							

Bibliography

- [1] ISO 2954:2012, *Mechanical vibration of rotating and reciprocating machinery — Requirements for instruments for measuring vibration severity*
- [2] ISO 8528-1:2005, *Reciprocating internal combustion engine driven alternating current generating sets — Part 1: Application, ratings and performance*
- [3] ISO 10816-6:1995, *Mechanical vibration — Evaluation of machine vibration by measurements on non-rotating parts — Part 6: Reciprocating machines with power ratings above 100 kW*

British Standards Institution (BSI)

BSI is the national body responsible for preparing British Standards and other standards-related publications, information and services.

BSI is incorporated by Royal Charter. British Standards and other standardization products are published by BSI Standards Limited.

About us

We bring together business, industry, government, consumers, innovators and others to shape their combined experience and expertise into standards-based solutions.

The knowledge embodied in our standards has been carefully assembled in a dependable format and refined through our open consultation process. Organizations of all sizes and across all sectors choose standards to help them achieve their goals.

Information on standards

We can provide you with the knowledge that your organization needs to succeed. Find out more about British Standards by visiting our website at bsigroup.com/standards or contacting our Customer Services team or Knowledge Centre.

Buying standards

You can buy and download PDF versions of BSI publications, including British and adopted European and international standards, through our website at bsigroup.com/shop, where hard copies can also be purchased.

If you need international and foreign standards from other Standards Development Organizations, hard copies can be ordered from our Customer Services team.

Copyright in BSI publications

All the content in BSI publications, including British Standards, is the property of and copyrighted by BSI or some person or entity that owns copyright in the information used (such as the international standardization bodies) and has formally licensed such information to BSI for commercial publication and use.

Save for the provisions below, you may not transfer, share or disseminate any portion of the standard to any other person. You may not adapt, distribute, commercially exploit, or publicly display the standard or any portion thereof in any manner whatsoever without BSI's prior written consent.

Storing and using standards

Standards purchased in soft copy format:

- A British Standard purchased in soft copy format is licensed to a sole named user for personal or internal company use only.
- The standard may be stored on more than 1 device provided that it is accessible by the sole named user only and that only 1 copy is accessed at any one time.
- A single paper copy may be printed for personal or internal company use only.

Standards purchased in hard copy format:

- A British Standard purchased in hard copy format is for personal or internal company use only.
- It may not be further reproduced – in any format – to create an additional copy. This includes scanning of the document.

If you need more than 1 copy of the document, or if you wish to share the document on an internal network, you can save money by choosing a subscription product (see 'Subscriptions').

Reproducing extracts

For permission to reproduce content from BSI publications contact the BSI Copyright & Licensing team.

Subscriptions

Our range of subscription services are designed to make using standards easier for you. For further information on our subscription products go to bsigroup.com/subscriptions.

With **British Standards Online (BSOL)** you'll have instant access to over 55,000 British and adopted European and international standards from your desktop. It's available 24/7 and is refreshed daily so you'll always be up to date.

You can keep in touch with standards developments and receive substantial discounts on the purchase price of standards, both in single copy and subscription format, by becoming a **BSI Subscribing Member**.

PLUS is an updating service exclusive to BSI Subscribing Members. You will automatically receive the latest hard copy of your standards when they're revised or replaced.

To find out more about becoming a BSI Subscribing Member and the benefits of membership, please visit bsigroup.com/shop.

With a **Multi-User Network Licence (MUNL)** you are able to host standards publications on your intranet. Licences can cover as few or as many users as you wish. With updates supplied as soon as they're available, you can be sure your documentation is current. For further information, email subscriptions@bsigroup.com.

Revisions

Our British Standards and other publications are updated by amendment or revision.

We continually improve the quality of our products and services to benefit your business. If you find an inaccuracy or ambiguity within a British Standard or other BSI publication please inform the Knowledge Centre.

Useful Contacts

Customer Services

Tel: +44 345 086 9001

Email (orders): orders@bsigroup.com

Email (enquiries): cservices@bsigroup.com

Subscriptions

Tel: +44 345 086 9001

Email: subscriptions@bsigroup.com

Knowledge Centre

Tel: +44 20 8996 7004

Email: knowledgecentre@bsigroup.com

Copyright & Licensing

Tel: +44 20 8996 7070

Email: copyright@bsigroup.com

BSI Group Headquarters

389 Chiswick High Road London W4 4AL UK