

BS ISO 8513:2016



BSI Standards Publication

Plastics piping systems — Glass-reinforced thermosetting plastics (GRP) pipes — Test methods for the determination of the initial longitudinal tensile strength

bsi.

...making excellence a habit.™

National foreword

This British Standard is the UK implementation of ISO 8513:2016. It supersedes BS ISO 8513:2014 which is withdrawn.

The UK participation in its preparation was entrusted to Technical Committee PRI/88/2, Plastics piping for pressure applications.

A list of organizations represented on this committee can be obtained on request to its secretary.

This publication does not purport to include all the necessary provisions of a contract. Users are responsible for its correct application.

© The British Standards Institution 2016.
Published by BSI Standards Limited 2016

ISBN 978 0 580 87693 6

ICS 23.040.20

Compliance with a British Standard cannot confer immunity from legal obligations.

This British Standard was published under the authority of the Standards Policy and Strategy Committee on 29 February 2016.

Amendments/corrigenda issued since publication

Date	Text affected
------	---------------

Plastics piping systems — Glass-reinforced thermosetting plastics (GRP) pipes — Test methods for the determination of the initial longitudinal tensile strength

Systèmes de canalisations en plastiques — Tubes en plastiques thermodurcissables renforcés de verre (PRV) — Méthodes d'essai pour la détermination de la force en traction longitudinale





COPYRIGHT PROTECTED DOCUMENT

© ISO 2016, Published in Switzerland

All rights reserved. Unless otherwise specified, no part of this publication may be reproduced or utilized otherwise in any form or by any means, electronic or mechanical, including photocopying, or posting on the internet or an intranet, without prior written permission. Permission can be requested from either ISO at the address below or ISO's member body in the country of the requester.

ISO copyright office
Ch. de Blandonnet 8 • CP 401
CH-1214 Vernier, Geneva, Switzerland
Tel. +41 22 749 01 11
Fax +41 22 749 09 47
copyright@iso.org
www.iso.org

Contents

	Page
Foreword	iv
Introduction	v
1 Scope	1
2 Terms and definitions	1
3 Principle	2
4 Apparatus	3
5 Test pieces	3
5.1 General.....	3
5.2 Strip test piece (method A).....	4
5.2.1 Shape.....	4
5.2.2 Dimensions.....	4
5.2.3 Use of built-up ends.....	6
5.3 Pipe section test pieces (method B).....	6
5.4 Number of test pieces.....	6
6 Conditioning	6
7 Test temperature	6
8 Procedure (methods A and B)	7
9 Calculation	7
9.1 For strip test pieces (method A).....	7
9.2 For pipe test pieces (method B).....	7
10 Test report	8
Annex A (informative) Determination of longitudinal properties for helically filament-wound thin wall pipe	9
Bibliography	11

Foreword

ISO (the International Organization for Standardization) is a worldwide federation of national standards bodies (ISO member bodies). The work of preparing International Standards is normally carried out through ISO technical committees. Each member body interested in a subject for which a technical committee has been established has the right to be represented on that committee. International organizations, governmental and non-governmental, in liaison with ISO, also take part in the work. ISO collaborates closely with the International Electrotechnical Commission (IEC) on all matters of electrotechnical standardization.

The procedures used to develop this document and those intended for its further maintenance are described in the ISO/IEC Directives, Part 1. In particular the different approval criteria needed for the different types of ISO documents should be noted. This document was drafted in accordance with the editorial rules of the ISO/IEC Directives, Part 2 (see www.iso.org/directives).

Attention is drawn to the possibility that some of the elements of this document may be the subject of patent rights. ISO shall not be held responsible for identifying any or all such patent rights. Details of any patent rights identified during the development of the document will be in the Introduction and/or on the ISO list of patent declarations received (see www.iso.org/patents).

Any trade name used in this document is information given for the convenience of users and does not constitute an endorsement.

For an explanation on the meaning of ISO specific terms and expressions related to conformity assessment, as well as information about ISO's adherence to the WTO principles in the Technical Barriers to Trade (TBT) see the following URL: [Foreword - Supplementary information](#).

The committee responsible for this document is ISO/TC 138, *Plastics pipes, fittings and valves for the transport of fluids*, Subcommittee SC 6, *Reinforced plastics pipes and fittings for all applications*.

This third edition cancels and replaces the second edition (ISO 8513:2014) which has been technically revised.

Introduction

Although this International Standard was revised in 2014, it was found necessary to again revise to correct several small errors in presentation and to revise the allowable testing speed (crosshead movement) range. A review of ISO testing standards for glass-reinforced thermosetting plastics (GRP) materials and the results of a recent testing program indicated that a testing speed of 2 mm/min to 5 mm/min is more appropriate. Also, evidence was presented that method C, the plate method, lead to results that were frequently from shear failures rather than tensile failures and lead to a falsely high prediction of Longitudinal Tensile Strength. Method C has been removed from this edition. Also, the term “Apparent” was removed from the title as it seemed to have no clear meaning.

Plastics piping systems — Glass-reinforced thermosetting plastics (GRP) pipes — Test methods for the determination of the initial longitudinal tensile strength

1 Scope

This International Standard specifies two test methods for determining the longitudinal tensile properties of glass-reinforced thermosetting plastics (GRP) pipes. The properties which can be determined are

- the longitudinal tensile strength, and
- the percentage ultimate elongation.

Method A uses, for the test piece(s), a longitudinal strip cut from a pipe.

Method B uses a specified length of the full cross-section of the pipe.

Method A is applicable to pipes with a nominal size of DN 50 or greater with circumferentially wound filaments, with or without chopped glass and/or woven rovings and/or fillers, and to centrifugally cast pipes. It is applicable to pipes with helically wound filaments with a nominal size of DN 200 or greater.

Method B is applicable to all types of GRP pipe. It is usually used for pipes with a nominal size up to and including DN 150.

Results from one method are not necessarily equal to the results derived from any of the alternative methods. However, all methods have equal validity.

[Annex A](#) describes additional considerations for method B that have been found useful for the testing of thin-walled helically wound pipes and can be used to supplement the basic text.

NOTE This International Standard does not address the determination of longitudinal tensile modulus. Due to the multi-layer construction of many GRP pipes, the accurate measurement of strain, necessary for modulus determination, can be very difficult. If it is desired to determine longitudinal modulus, see ISO 527-4 and/or ISO 527-5.

2 Terms and definitions

For the purposes of this document, the following terms and definitions apply.

2.1

helical wound

refers to filament-wound pipes made with a balanced winding angle

Note 1 to entry: Sometimes called cross wound.

2.2

longitudinal tensile strength

σ_{LA}^*

σ_{LB}^*

maximum tensile force in the longitudinal direction per unit mean circumference at failure

Note 1 to entry: It is expressed in newtons per millimetre of the circumference (N/mm).

Note 2 to entry: The subscripts A and B denote the method of test used.

2.3 mean circumference

circumference corresponding to the mean diameter multiplied by π ($\pi \approx 3,141\ 6$)

Note 1 to entry: It is expressed in millimetres.

2.4 mean diameter

d_m
diameter of the circle corresponding with the middle of the pipe wall cross-section

Note 1 to entry: It is given by any of the following:

- a) the average of the external diameter of the pipe minus the average of the wall thickness;
- b) the external circumference of the pipe divided by π ($\pi \approx 3,141\ 6$) minus the average of the wall thickness;
- c) the average of the internal diameter of the pipe plus the average of the wall thickness.

Note 2 to entry: It is expressed in millimetres.

2.5 ultimate longitudinal tensile stress

$\sigma_{L,ULT}$
maximum longitudinal tensile force per unit cross-sectional area at failure

Note 1 to entry: It is expressed in newtons per square millimetre (N/mm).

2.6 ultimate elongation

ε_L
elongation coincident with the ultimate longitudinal tensile stress

Note 1 to entry: For the purposes of this International Standard, the measurement of elongation is limited to measurement of the movement of the tensile testing machine cross-heads.

Note 2 to entry: It is expressed as a percentage of an initial gauge length or free length of a test piece.

3 Principle

Test pieces comprising either strips cut longitudinally from a pipe wall segment (method A) or a specified length of pipe (method B) are subjected to extension in the longitudinal direction at a constant speed such that fracture occurs within a specified time.

The tensile properties are determined using the initial dimensions of the test piece, the tensile force, and the cross-head movement.

NOTE It is assumed that the following test parameters are set by the standard making reference to this International Standard:

- a) the methods to be used, i.e. method A or method B;
- b) the number of test pieces (see [5.4](#));
- c) if applicable, the requirements for conditioning, e.g. temperature, humidity, time, and associated tolerances (see [Clause 6](#));
- d) the test temperature and its tolerance (see [Clause 7](#));
- e) the properties to be measured (see [Clause 8](#)).

4 Apparatus

4.1 Tensile-testing machine, of the constant rate of cross-head movement type, incorporating the following features:

- a) a fixed part, fitted with a grip to hold one end of the test piece without permitting any longitudinal movement thereof, and a moveable part, incorporating a grip to hold the other end of the test piece during extension [the fixed and moving parts and their associated grips (see 4.2) shall enable the test piece to be aligned when a force is applied so that its longitudinal axis coincides with the direction of this force];
- b) a drive mechanism, capable of imparting a constant speed (see 8.3) to the moving part;
- c) a force indicator, capable of measuring the force applied to a test piece which is held in the grips (the mechanism shall be free from significant inertia lag at the necessary speed of testing and shall indicate or record force, or consequent stress, with an accuracy of within ± 1 % of the value to be measured);
- d) a means to measure the cross-head movement as a function of the applied load.

4.2 Grips, for holding the test piece.

Each of the two grips shall be capable of holding one end of the test piece without slip or crushing to an extent that will affect the results obtained. Grips which tighten automatically might be suitable. Typical grips for a pipe section test piece (see 5.3) are shown in Figure 1.

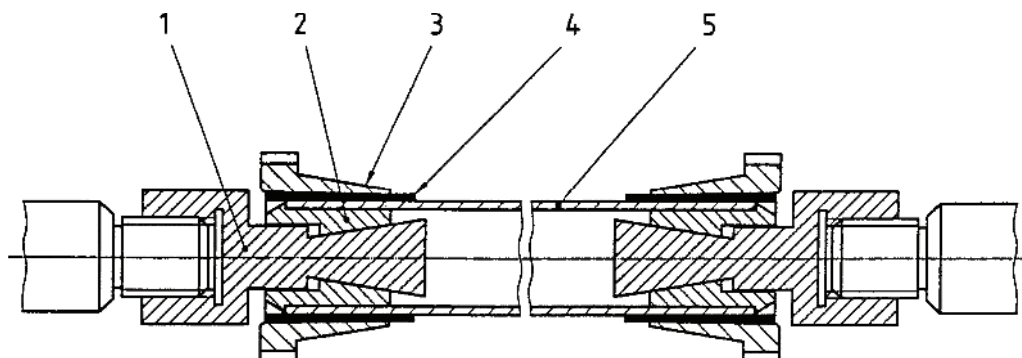

Key

- 1 mandrel
- 2 segmented grips
- 3 sleeve
- 4 reinforcing band
- 5 test piece

Figure 1 — Typical grips for a pipe section test piece (method B)

4.3 Dimension measurement devices, capable of measuring the necessary dimensions of the test piece (e.g. length, width, wall thickness) to an accuracy of half the accuracy required in Clause 8 for measurements, e.g. a measuring accuracy of $\pm 0,1$ mm requires a device accuracy of $\pm 0,05$ mm.

5 Test pieces

5.1 General

The test piece shall be a strip or dumbbell conforming to 5.2, or a pipe section conforming to 5.3.

The test piece shall be obtained in such a way that it is not damaged.

The test piece width guidelines might, of necessity, need to be altered for thick wall pipes to smaller values to reflect the testing machine capacity. This is due to some GRP pipes being made in very high thickness to address high pressure and large diameter applications. The testing of such narrower samples will lead to a more conservative indication of strength for thick wall pipes.

For thick wall test pieces, it might also be necessary to clamp the specimen on the cut cross-section sides to allow the specimen to fit into the testing grips.

For pipes with a layered wall construction, it might also be necessary to reinforce the gripped ends to obtain a more even distribution of tensile force.

For pipes reinforced in the axial direction with tapes, fabrics, or mats of a fixed width, it might be necessary to increase the test sample length to ensure that a cross-section with the minimum number of layers of reinforcement (the apparent lowest strength area) falls within the gauge length.

NOTE The test pieces for method A can be cut from a ring previously used for the determination of the initial specific ring stiffness.

5.2 Strip test piece (method A)

5.2.1 Shape

Each test piece shall be a strip cut in the longitudinal direction of the pipe and either shaped to the dimensions of the applicable dumbbell as shown in [Figure 2](#) or a parallel-sided (rectangular) test piece as shown in [Figure 3](#).

5.2.2 Dimensions

5.2.2.1 Length

The length, l , of the test piece shall be (300 ± 15) mm (see [Figure 2](#) and [Figure 3](#)).

5.2.2.2 Shaped strip

The gauge length, l_G , of the test piece shall be as follows (see [Figure 2](#)):

$$100 \text{ mm} \leq l_G \leq 150 \text{ mm} \quad (1)$$

The radius, R , shall be machined to conform to the following limits (see [Figure 2](#)):

$$50 \text{ mm} \leq R \leq 70 \text{ mm} \quad (2)$$

The width, b_G , of the test piece within the gauge length shall conform to the following requirements (see [Figure 2](#) and [5.2.1](#)):

$$b_G = (10 \pm 1) \text{ mm for DN} \leq 150 \quad (3)$$

$$b_G = (25 \pm 1) \text{ mm for DN} > 150 \quad (4)$$

The total width, b , of the test piece shall conform to the following requirements (see [Figure 2](#)):

$$b = (18 \pm 2) \text{ mm for DN} \leq 150 \quad (5)$$

$$b = (40 \pm 2) \text{ mm for DN} > 150 \quad (6)$$

The above width guidelines might need to be reduced to accommodate thick wall pipes (see 5.1).

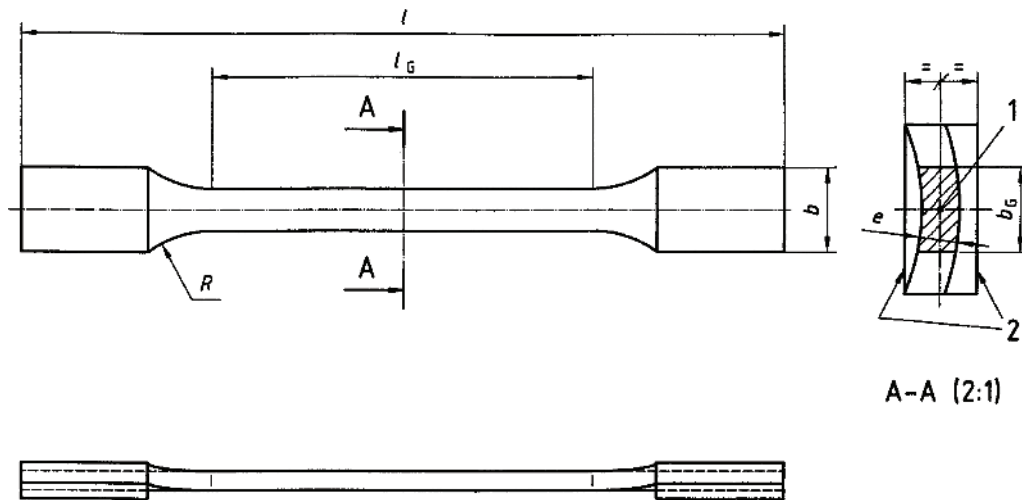

Key

- 1 centroid of gauge length cross-section
- 2 ends built up with plain or reinforced thermoset resin and trimmed flat and parallel, if required
- e* wall thickness
- l* test sample length
- l_G* gauge length
- b* total test sample width
- b_G* width of gauge length
- R* radius

Figure 2 — Shaped test piece dimensions (method A)

5.2.2.3 Parallel-sided strip

The width, *b_G*, of the test piece within the gauge length shall conform to the following requirements (see Figure 3). The gauge length, *l_G*, shall be the non-built up area between the grips.

The width, *b* (equal to the gauge width *b_G*), of the test piece shall be as follows (see Figure 3):

$$b_G = (10 \pm 1) \text{ mm for DN} \leq 150 \quad (7)$$

$$b_G = (25 \pm 1) \text{ mm for DN} > 150 \quad (8)$$

The above width guidelines might need to be reduced to accommodate thick wall pipes (see 5.1).

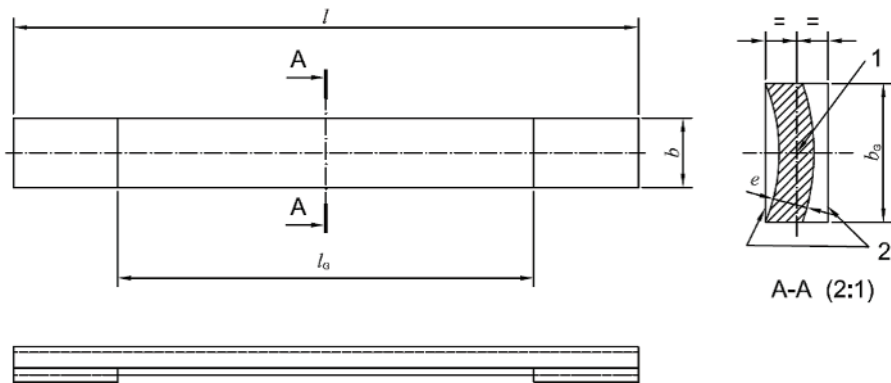

Key

- 1 centroid of gauge length cross-section
- 2 ends built up with plain or reinforced thermoset resin and trimmed flat and parallel, if required
- e wall thickness
- l test sample length
- l_G gauge length
- b test sample width = gauge width b_G

Figure 3 — Parallel-sided strip test piece dimensions (method A)

5.2.3 Use of built-up ends

Unless grips (see 4.2) with close-fitting curved jaws are to be used, and if the manufacturer elects to utilize built-up ends, build up the thickness of the test piece ends over the grip length with a suitable thermosetting resin with or without reinforcement.

When cured, machine the built-up ends flat and parallel and ensure that the centroid of the gauge length cross-section (see Figure 2 and Figure 3) will lie on the loading centreline of the testing machine when gripped.

5.3 Pipe section test pieces (method B)

Each test piece (see Figure 1) shall be a full section of the pipe with a minimum length of 450 mm

5.4 Number of test pieces

The number of test pieces shall be as specified in the referring standard.

6 Conditioning

Unless otherwise specified in the referring standard, store the test pieces at the test temperature (see Clause 7) for at least 0,5 h prior to testing.

7 Test temperature

Conduct the applicable procedure given in Clause 8 at the temperature specified in the referring standard.

8 Procedure (methods A and B)

8.1 For a strip test piece (method A), measure and record to the nearest 0,1 mm the wall thickness e and the widths b and b_G , as applicable, of the test piece, at the centre of the gauge length.

For a pipe test piece (method B), measure and record either the internal or the external diameter and the average wall thickness of the test piece by taking three measurements equally spaced around the circumference at both ends of the pipe section.

8.2 Place the test piece in the tensile-testing machine (4.1) so that the axial alignment coincides with the direction of pull and clamp the grips (4.2) uniformly and sufficiently tight to prevent slipping of the test piece.

8.3 Load the test piece by separating the grips at a constant speed of between 2 mm/min to 5 mm/min and record forces and corresponding elongations at appropriate intervals. Record the maximum force sustained by the test piece, in newtons.

8.4 Discard any test pieces which have slipped in the grips and those for which rupture has occurred outside the gauge length, and repeat the test(s) on a corresponding number of test pieces conforming to 5.2, 5.3 or 5.4.

NOTE If failures occur outside the gauge length, it is allowed to include such failures if the resulting average strength is increased.

9 Calculation

9.1 For strip test pieces (method A)

9.1.1 For each test piece, calculate the initial longitudinal tensile strength, $\sigma_{LA,i}^*$, in N/mm of the circumference, using Formula (9):

$$\sigma_{LA,i}^* = \frac{F}{b_G} \quad (9)$$

where

F is the maximum force in N;

b_G is the gauge width of the test piece, in mm;

i is the number of the test piece.

Calculate the average initial longitudinal tensile strength, $\sigma_{LA,i}^*$, of the test pieces and, if applicable, the standard deviation.

9.1.2 For each test piece, calculate the percentage ultimate elongation. For all the test pieces, determine the average percentage ultimate elongation and the standard deviation, if applicable.

9.2 For pipe test pieces (method B)

9.2.1 For each test piece, calculate the initial longitudinal tensile strength, $\sigma_{LB,i}^*$, in N/mm of the circumference, using Formula (10):

$$\sigma_{LB,i}^* = \frac{F}{\pi \times d_m} \quad (10)$$

where

- F is the maximum force, in N;
- d_m is the mean diameter (see 2.4), in mm;
- i is the number of the test piece.

Calculate the average initial longitudinal tensile strength, σ_{LB}^* , of the test pieces and, if applicable, the standard deviation.

9.2.2 For each test piece, calculate the percentage ultimate elongation, $\varepsilon_{L,i}$. For all the test pieces, determine the average percentage ultimate elongation, ε_L , and the standard deviation, if applicable.

10 Test report

The test report shall include the following information:

- a) a reference to this International Standard, i.e. ISO 8513:2016, and to the referring standard;
- b) all details necessary for full identification of the pipe tested;
- c) the test method used, i.e. method A or method B;
- d) in the case of a strip test piece, whether it was parallel-sided or shaped and whether or not the ends were built-up;
- e) the average wall thickness and the length of each test piece and other relevant dimensions, as applicable;
- f) the number of test pieces;
- g) the positions in the pipe from which the test pieces were obtained;
- h) the temperature during the test;
- i) the rate of loading;
- j) the elapsed time to failure;
- k) the individual value(s) for the initial longitudinal tensile strength and/or the ultimate longitudinal tensile stress, the average value and, if applicable, the standard deviation;
- l) the individual percentage ultimate elongation and the gauge length over which the elongation was measured and the average percentage ultimate elongation and, if applicable, the standard deviation;
- m) the results of any load/elongation in either graphical or numerical form;
- n) a description of the appearance of the test pieces after testing;
- o) any factors which might have influenced the results, such as any incidents or operating details not specified in this International Standard;
- p) the date of the test.

Annex A (informative)

Determination of longitudinal properties for helically filament-wound thin wall pipe

A.1 General

This Annex can be useful for the determination of longitudinal tensile properties of helical filament wound small-diameter thin wall pipe tested by method B. Only those exceptions or additions to the base standard are addressed in this Annex.

A.2 Method B

Testing of thin wall pipe can lead to buckling of the pipe before longitudinal tensile failure. Therefore, an internal “core” support can be used to prevent buckling failure (see [Figure A.1](#))

Obtaining a tight grip on a thin wall pipe can be difficult and reinforcing the gripped area with metallic tabs cut from a section of aluminium pipe has been found effective in preventing grip failures. The tabs are bonded to the test specimen using glass fibre fabric tape and thermosetting resin. A typical example to illustrate preparation of metal tabs is shown in [Figure A.2](#). An example of the application of the fabric tape is shown in [Figure A.3](#). The suggested boundary configuration, which is to taper the tape build up over approximately 30 mm, is shown in [Figure A.4](#).

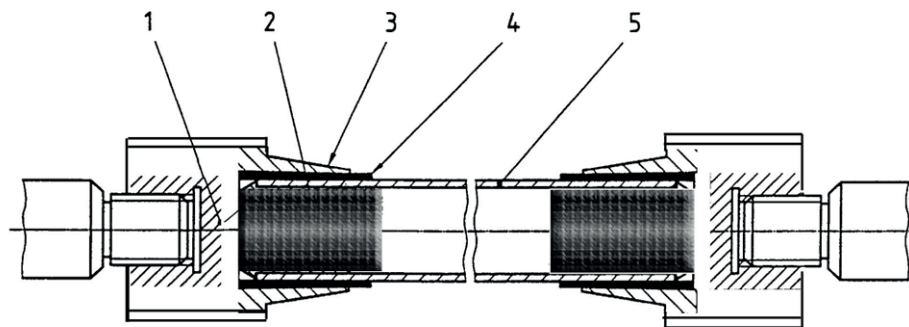

Key

- 1 core
- 2 segmented grips
- 3 sleeve
- 4 reinforcing band (metallic)
- 5 test piece

Figure A.1 — Typical grips for a pipe section test piece

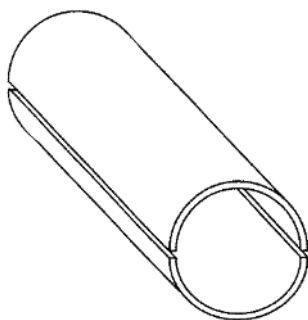

Figure A.2 — Preparation of metallic tabs

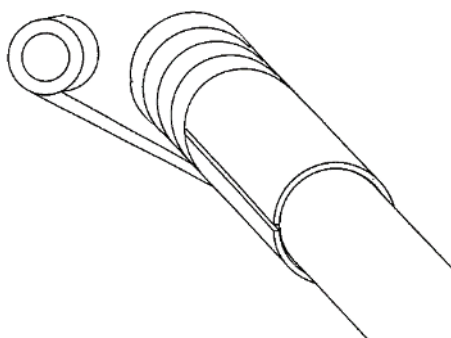
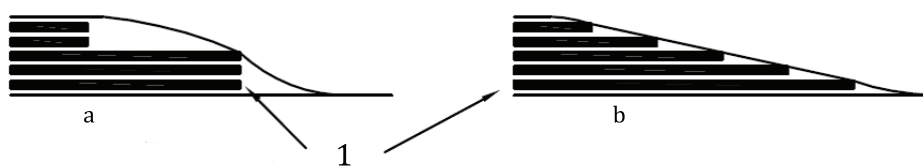

Figure A.3 — Winding tape over the tabs



Key

- 1 fabric material
- a Not recommended.
- b Recommended.

Figure A.4 — Suggested configuration of the boundary between tab and cylinder

Bibliography

- [1] ISO 527-4, *Plastics — Determination of tensile properties — Part 4: Test conditions for isotropic and orthotropic fibre-reinforced plastic composites*
- [2] ISO 527-5, *Plastics — Determination of tensile properties — Part 5: Test conditions for unidirectional fibre-reinforced plastic composites*

British Standards Institution (BSI)

BSI is the national body responsible for preparing British Standards and other standards-related publications, information and services.

BSI is incorporated by Royal Charter. British Standards and other standardization products are published by BSI Standards Limited.

About us

We bring together business, industry, government, consumers, innovators and others to shape their combined experience and expertise into standards-based solutions.

The knowledge embodied in our standards has been carefully assembled in a dependable format and refined through our open consultation process. Organizations of all sizes and across all sectors choose standards to help them achieve their goals.

Information on standards

We can provide you with the knowledge that your organization needs to succeed. Find out more about British Standards by visiting our website at bsigroup.com/standards or contacting our Customer Services team or Knowledge Centre.

Buying standards

You can buy and download PDF versions of BSI publications, including British and adopted European and international standards, through our website at bsigroup.com/shop, where hard copies can also be purchased.

If you need international and foreign standards from other Standards Development Organizations, hard copies can be ordered from our Customer Services team.

Subscriptions

Our range of subscription services are designed to make using standards easier for you. For further information on our subscription products go to bsigroup.com/subscriptions.

With **British Standards Online (BSOL)** you'll have instant access to over 55,000 British and adopted European and international standards from your desktop. It's available 24/7 and is refreshed daily so you'll always be up to date.

You can keep in touch with standards developments and receive substantial discounts on the purchase price of standards, both in single copy and subscription format, by becoming a **BSI Subscribing Member**.

PLUS is an updating service exclusive to BSI Subscribing Members. You will automatically receive the latest hard copy of your standards when they're revised or replaced.

To find out more about becoming a BSI Subscribing Member and the benefits of membership, please visit bsigroup.com/shop.

With a **Multi-User Network Licence (MUNL)** you are able to host standards publications on your intranet. Licences can cover as few or as many users as you wish. With updates supplied as soon as they're available, you can be sure your documentation is current. For further information, email bsmusales@bsigroup.com.

Revisions

Our British Standards and other publications are updated by amendment or revision.

We continually improve the quality of our products and services to benefit your business. If you find an inaccuracy or ambiguity within a British Standard or other BSI publication please inform the Knowledge Centre.

Copyright

All the data, software and documentation set out in all British Standards and other BSI publications are the property of and copyrighted by BSI, or some person or entity that owns copyright in the information used (such as the international standardization bodies) and has formally licensed such information to BSI for commercial publication and use. Except as permitted under the Copyright, Designs and Patents Act 1988 no extract may be reproduced, stored in a retrieval system or transmitted in any form or by any means – electronic, photocopying, recording or otherwise – without prior written permission from BSI. Details and advice can be obtained from the Copyright & Licensing Department.

Useful Contacts:

Customer Services

Tel: +44 845 086 9001

Email (orders): orders@bsigroup.com

Email (enquiries): cservices@bsigroup.com

Subscriptions

Tel: +44 845 086 9001

Email: subscriptions@bsigroup.com

Knowledge Centre

Tel: +44 20 8996 7004

Email: knowledgecentre@bsigroup.com

Copyright & Licensing

Tel: +44 20 8996 7070

Email: copyright@bsigroup.com

BSI Group Headquarters

389 Chiswick High Road London W4 4AL UK

