

Self-propelled machinery for forestry — Laboratory tests and performance requirements for roll-over protective structures

Part 1: General machines

ICS 65.060.80

National foreword

This British Standard is the UK implementation of ISO 8082-1:2009. It supersedes BS ISO 8082:2003 which is withdrawn.

The UK participation in its preparation was entrusted to Technical Committee AGE/29, Forestry machinery.

A list of organizations represented on this committee can be obtained on request to its secretary.

This publication does not purport to include all the necessary provisions of a contract. Users are responsible for its correct application.

Compliance with a British Standard cannot confer immunity from legal obligations.

This British Standard was published under the authority of the Standards Policy and Strategy Committee on 30 September 2009

© BSI 2009

ISBN 978 0 580 65801 3

Amendments/corrigenda issued since publication

Date	Comments

INTERNATIONAL STANDARD

ISO
8082-1

First edition
2009-08-15

Self-propelled machinery for forestry — Laboratory tests and performance requirements for roll-over protective structures —

Part 1: General machines

Machines forestières automotrices — Essais de laboratoire et exigences de performance pour les structures de protection au retournement —

Partie 1: Machines communes



Reference number
ISO 8082-1:2009(E)

PDF disclaimer

This PDF file may contain embedded typefaces. In accordance with Adobe's licensing policy, this file may be printed or viewed but shall not be edited unless the typefaces which are embedded are licensed to and installed on the computer performing the editing. In downloading this file, parties accept therein the responsibility of not infringing Adobe's licensing policy. The ISO Central Secretariat accepts no liability in this area.

Adobe is a trademark of Adobe Systems Incorporated.

Details of the software products used to create this PDF file can be found in the General Info relative to the file; the PDF-creation parameters were optimized for printing. Every care has been taken to ensure that the file is suitable for use by ISO member bodies. In the unlikely event that a problem relating to it is found, please inform the Central Secretariat at the address given below.



COPYRIGHT PROTECTED DOCUMENT

© ISO 2009

All rights reserved. Unless otherwise specified, no part of this publication may be reproduced or utilized in any form or by any means, electronic or mechanical, including photocopying and microfilm, without permission in writing from either ISO at the address below or ISO's member body in the country of the requester.

ISO copyright office
Case postale 56 • CH-1211 Geneva 20
Tel. + 41 22 749 01 11
Fax + 41 22 749 09 47
E-mail copyright@iso.org
Web www.iso.org

Published in Switzerland

Contents

Page

Foreword	iv
1 Scope	1
2 Normative references	1
3 Terms, definitions and symbols	2
4 Static laboratory tests	4
5 Performance requirements	11
6 Reporting results	13
Annex A (normative) Test report for ISO 8082-1	14
Bibliography	16

Foreword

ISO (the International Organization for Standardization) is a worldwide federation of national standards bodies (ISO member bodies). The work of preparing International Standards is normally carried out through ISO technical committees. Each member body interested in a subject for which a technical committee has been established has the right to be represented on that committee. International organizations, governmental and non-governmental, in liaison with ISO, also take part in the work. ISO collaborates closely with the International Electrotechnical Commission (IEC) on all matters of electrotechnical standardization.

International Standards are drafted in accordance with the rules given in the ISO/IEC Directives, Part 2.

The main task of technical committees is to prepare International Standards. Draft International Standards adopted by the technical committees are circulated to the member bodies for voting. Publication as an International Standard requires approval by at least 75 % of the member bodies casting a vote.

Attention is drawn to the possibility that some of the elements of this document may be the subject of patent rights. ISO shall not be held responsible for identifying any or all such patent rights.

ISO 8082-1 was prepared by Technical Committee ISO/TC 23, *Tractors and machinery for agriculture and forestry*, Subcommittee SC 15, *Machinery for forestry*.

This first edition of ISO 8082-1 cancels and replaces ISO 8082:2003, of which it constitutes a minor revision. Whereas machines having a rotating platform with cab and boom on the platform remain excluded from the scope of this part of ISO 8082, the restructuring of the standard into discrete parts allows those machines to be addressed in ISO 8082-2.

ISO 8082 consists of the following parts, under the general title *Self-propelled machinery for forestry — Laboratory tests and performance requirements for roll-over protective structures*:

- *Part 1: General machines*
- *Part 2: Machines having a rotating platform with a cab and boom on the platform*

Self-propelled machinery for forestry — Laboratory tests and performance requirements for roll-over protective structures —

Part 1: General machines

1 Scope

This part of ISO 8082 establishes a consistent, reproducible means of evaluating the force–deflection characteristics of roll-over protective structures (ROPS) on self-propelled forestry machines under static loading, and prescribes performance requirements for a representative specimen under such loading. It is applicable to forwarders, skidders, feller-bunchers, processors, harvesters and log loaders, as defined in ISO 6814. It is not applicable to machines having a rotating platform with a cab and boom on the platform, which are addressed by ISO 8082-2.

NOTE The requirement levels and testing procedures of this part of ISO 8082 are the same as those of ISO 3471 [2].

2 Normative references

The following referenced documents are indispensable for the application of this document. For dated references, only the edition cited applies. For undated references, the latest edition of the referenced document (including any amendments) applies.

ISO 148-1, *Metallic materials — Charpy pendulum impact test — Part 1: Test method*

ISO 898-1, *Mechanical properties of fasteners made of carbon steel and alloy steel — Part 1: Bolts, screws and studs with specified property classes — Coarse thread and fine pitch thread*

ISO 898-2:1992, *Mechanical properties of fasteners — Part 2: Nuts with specified proof load values — Coarse thread*

ISO 3164, *Earth-moving machinery — Laboratory evaluations of protective structures — Specifications for deflection-limiting volume*

ISO 6814, *Machinery for forestry — Mobile and self-propelled machinery — Terms, definitions and classification*

3 Terms, definitions and symbols

For the purposes of this document, the following terms, definitions and symbols (see Table 1) apply.

3.1 roll-over protective structure ROPS

system of structural members whose primary purpose is to reduce the possibility of a seat-belted operator being crushed should the machine roll over

NOTE These structural members include any subframe, bracket, mounting, socket, bolt, pin, suspension or flexible shock absorber used to secure the system to the machine frame, but exclude mounting provisions that are integral with the machine frame.

3.2 deflection-limiting volume DLV

orthogonal approximation of a large, seated, male operator as defined in ISO 3411 wearing normal clothing and a protective helmet

3.3 falling-object protective structure FOPS

system of structural members arranged in such a way as to provide operators with reasonable protection from falling objects (e.g. trees, rocks)

3.4 operator protective structure OPS

system of structural members arranged in such a way as to minimize the possibility of operator injury from penetrating objects (such as whipping saplings, branches and broken winch lines)

3.5 simulated ground plane SGP

flat surface on which, after rolling, a forestry machine is assumed to come to rest

3.5.1 lateral simulated ground plane LSGP

for a machine coming to rest on its side, the plane 15° away from the DLV about the horizontal axis within the plane established in the vertical plane passing through the outermost point

See Figure 1.

NOTE The LSGP is established on an unloaded ROPS and moves with the member to which load is applied while maintaining its 15° angle with respect to the vertical.

3.5.2 vertical simulated ground plane VSGP

⟨rollbar ROPS⟩ for a machine coming to rest in an upside-down position, the plane defined by the top cross-member of the ROPS and that front (or rear) part of the machine likely to come in contact with flat ground at the same time as the ROPS and capable of supporting the upside-down machine

NOTE The VSGP moves with the deformed ROPS.

**3.6
 machine mass**

m

maximum mass declared by the manufacturer, including attachments in the operating condition and with tools, ROPS and all reservoirs filled, but excluding towed equipment (e.g. chippers, planters, discs) and any load that could be carried on the machine

Table 1 — Symbols

Symbol	Description	Unit
<i>U</i>	Energy absorbed by the structure, related to machine mass	J
<i>F</i>	Force	N
<i>m</i>	Machine mass	kg
Δ	Deflection of ROPS	mm

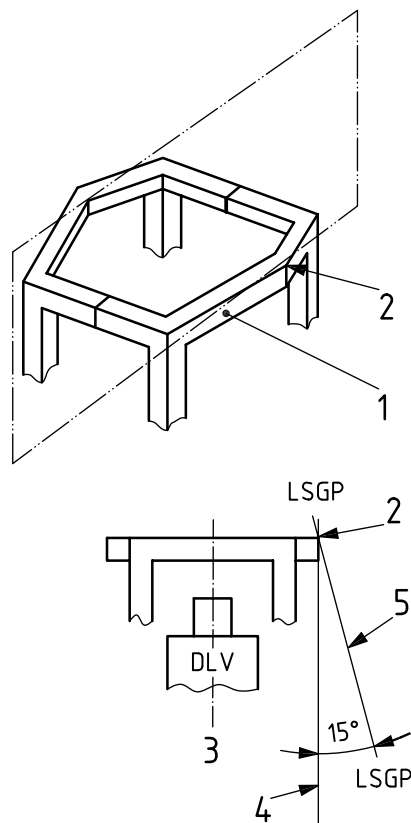

Key

- 1 upper ROPS member to which the lateral load is applied
- 2 outermost point from the end view of member (1)
- 3 vertical plane parallel to the machine longitudinal centreline through line (4)
- 4 vertical line through point (2)
- 5 lateral simulated ground plane

Figure 1 — Determination of lateral simulated ground plane (LSGP)

4 Static laboratory tests

CAUTION — Some of the tests specified in this part of ISO 8082 involve the use of processes which could lead to a hazardous situation.

4.1 Facilities

Facilities for securing the ROPS/machine frame assembly to the bedplate, as specified in the following, and for applying lateral, longitudinal and vertical loads, shall be provided.

The DLV and its location shall be in accordance with ISO 3164. The DLV shall be fixed firmly to the same part of the machine to which the operator's seat is normally secured, and shall remain there during the entire formal test period. For machines with a reversible operator's position, the DLV is to be considered as the combined clearance zones for the two positions.

4.2 Instruments

The test apparatus shall be equipped with instruments for measuring the force applied to the protective structure and the deflection (deformation) of the structure. The instrument accuracy shall be in accordance with Table 2.

Table 2 — Instrument accuracy requirements

Measurement	Accuracy ^a
Deflection of ROPS	± 5 % of maximum deflection measured
Force applied to ROPS	± 5 % of maximum force measured

^a The percentages are nominal ratings of the accuracy of the instrumentation and shall not be taken to indicate that a compensating overtest is required.

4.3 Apparatus

4.3.1 General

4.3.1.1 Assembly of ROPS to machine frame

The ROPS shall be attached to the machine frame or body as it would be on an operating machine. A complete machine is not required for the evaluation; however, the machine frame or body and ROPS mounting shall represent an operating installation. All normally detachable windows, panels, doors and other non-structural elements shall be removed so that they neither contribute to, nor detract from, the structural evaluation.

4.3.1.2 ROPS/machine attachment to bedplate

The ROPS/machine-frame assembly shall be secured to the bedplate so that the members connecting the assembly and bedplate experience minimal deflection during testing. During lateral loading, the ROPS/machine-frame assembly shall not receive any support from the bedplate, other than that due to the initial attachment.

Connections to the bedplate shall be directly from the machine frame at or near the front-axle support and the rear drive support. For articulated machines, if both frames are used in the evaluation, the hinge shall be locked so that the frames are in a straight line. If the frame on which the ROPS is mounted is used alone, the connections shall be at or near the extreme ends of the frame (see Figure 2).

4.3.1.3 Elimination of energy absorbers

The assembly shall be secured or modified or both so that any machine element that might be considered as suspension (rubber, gas, gas-oil or mechanical spring) shall be effectively eliminated as an energy absorber. However, the ROPS-structural members may include suspension or flexible shock absorbers, which shall not be altered.

4.3.2 Vertical loading

For vertical loading, there is no limitation on securing or supporting the ROPS/machine-frame assembly, except that no repair or straightening of the assembly shall be carried out.

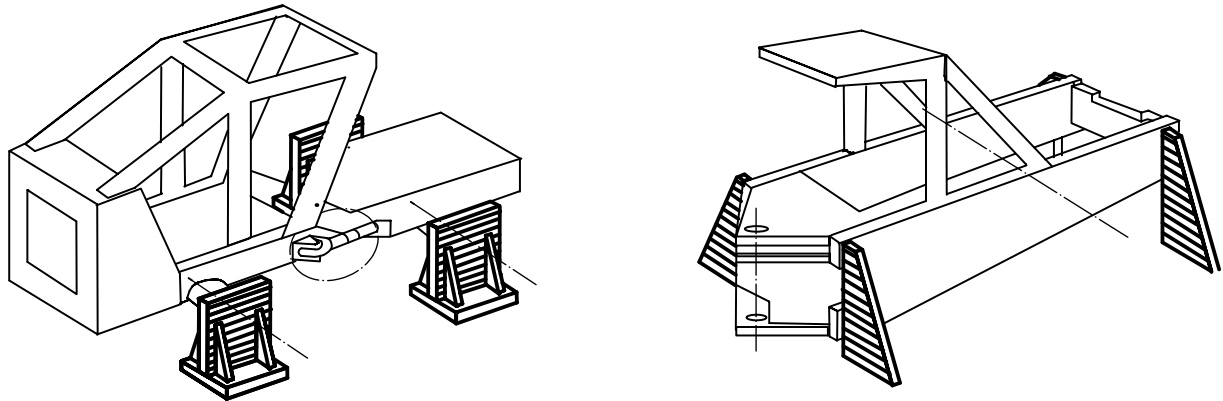

Figure 2 — Machine attachment to bedplate

4.4 Test procedures

4.4.1 General

The test procedures shall consist of the operations specified in 4.4.2 (lateral loading), 4.4.3 (vertical loading) and 4.4.4 (longitudinal loading), carried out in that order.

No repair or straightening of any ROPS/machine member shall be carried out during or between the lateral, vertical and longitudinal loading.

NOTE The figures referred to are illustrative and not intended to restrict the design of loading devices.

4.4.2 Lateral loading

4.4.2.1 The force–deflection characteristics shall be determined by lateral loading of the top major longitudinal members of the ROPS.

4.4.2.2 For a ROPS having more than two posts, the lateral loading shall be applied through a load-distribution device having a length not greater than 80 % of the horizontal distance, L , between the front and rear posts of the ROPS (see Figure 3). In the case of curved structural members, the load-distribution device may be attached to the ROPS but shall not have any affect on the strength of the ROPS.

4.4.2.3 For all one- or two-post ROPS, initial loading shall be dictated by the length, L , and the vertical projections of the front and rear planes of the DLV. The load application point may not be within $L/3$ of the ROPS structure. Should the $L/3$ point be between the vertical projection of the DLV and the ROPS structure, the load application point shall be moved away from the structure until it enters the vertical projection of the DLV (see Figure 4).

4.4.2.4 The initial direction of loading shall be horizontal and perpendicular to a vertical plane through the machine's longitudinal centreline. As loading continues, the ROPS/machine-frame deformations can cause the direction of loading to change: this is permissible.

4.4.2.5 If the operator's seat is off the machine's longitudinal centreline, the loading shall be against the outermost side nearest the seat. For on-centrelines seats, if mounting of the ROPS is such that different force-deflection relations are obtained from loading from left or right, the side loaded shall be that which will place the most severe requirements on the ROPS/machine assembly.

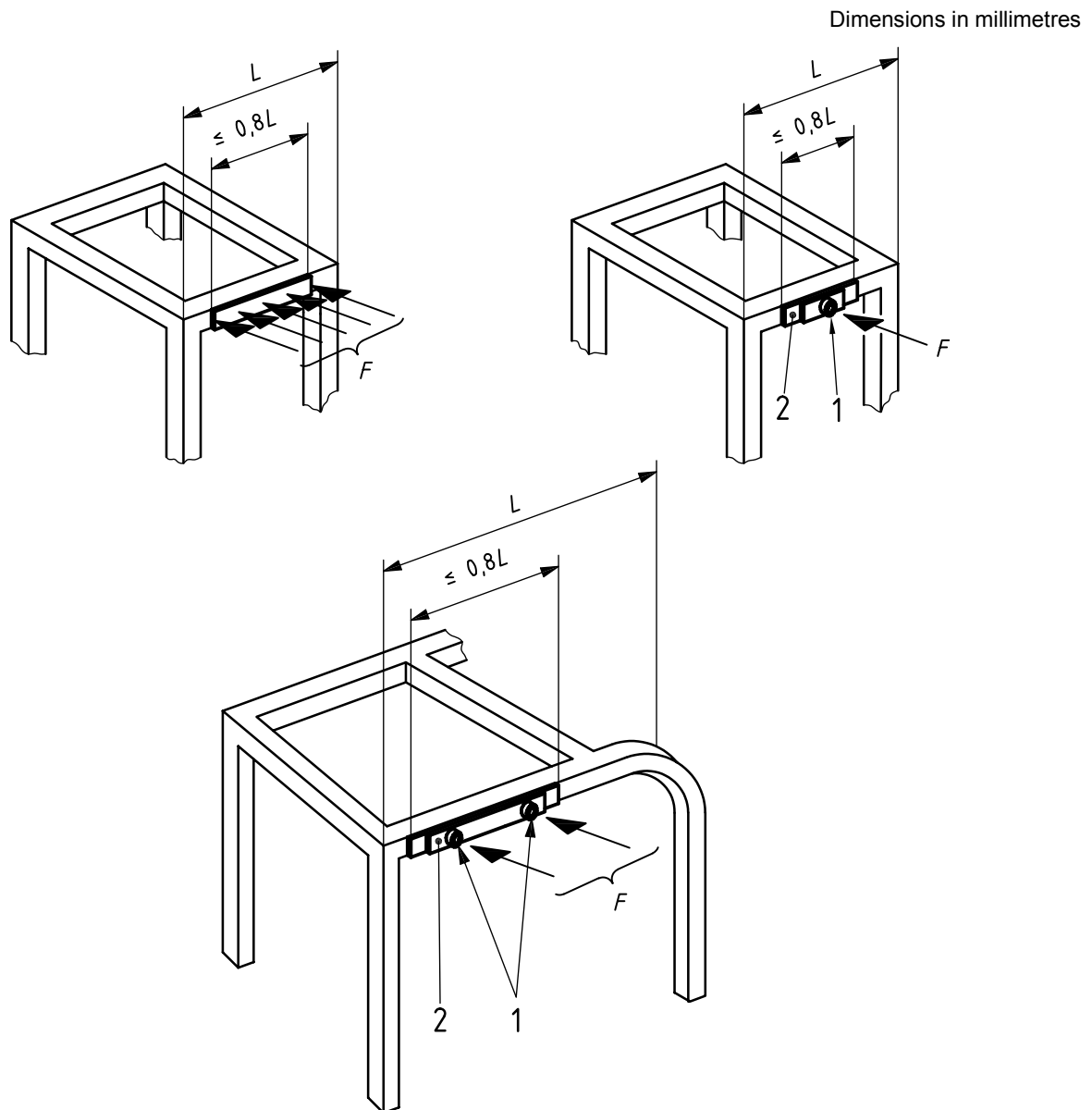

Key

- 1 socket
- 2 load distributor

NOTE 1 The load distributor and socket are to prevent local penetration and to hold the end of the load-generating device.

NOTE 2 Typical, but not mandatory, layout.

Figure 3 — Load-distribution device for ROPS with four-post system

4.4.2.6 The rate of application of deflection (load) shall be such that it can be considered static, i.e. a speed of < 5 mm/s. At deflection increments no greater than 15 mm at the point of application of the resultant load, the force and deflection shall be recorded and plotted. The loading shall be continued until the ROPS has achieved both the force and energy requirements. The area under the resulting force–deflection curve equals the energy (see Figure 5). The deflection or deflections used in calculating energy shall be that of the ROPS along the line(s) of action of the force(s). Any deflection of members used to support load-application devices shall not be included in deflection measurements used for the calculation of energy.

Dimensions in millimetres

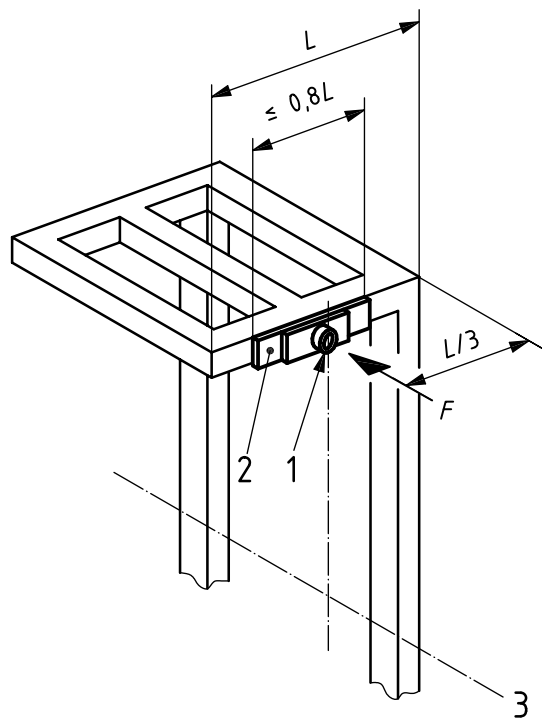

Key

- 1 socket
- 2 load distributor
- 3 locating axis (LA) of DLV

Figure 4 — Load-distribution device for ROPS with two-post system

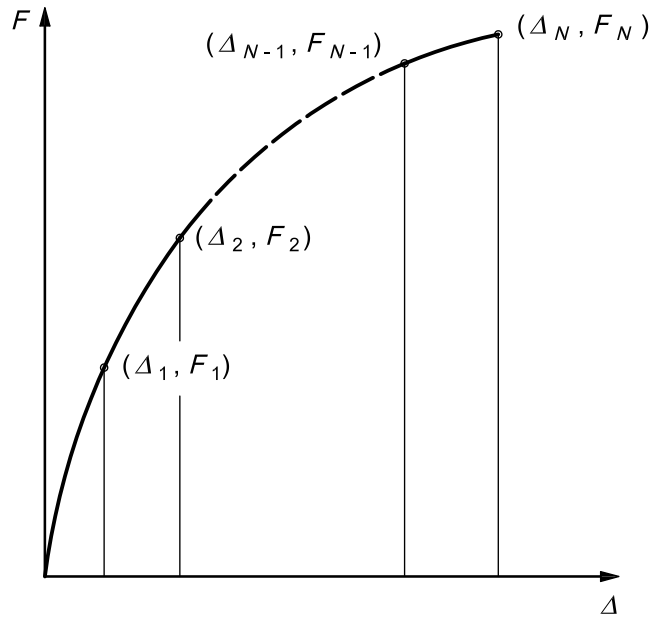

Key

F force

Δ deflection

U energy

$$U = \frac{\Delta_1 F_1}{2} + (\Delta_2 - \Delta_1) \frac{F_1 + F_2}{2} + \dots + (\Delta_N - \Delta_{N-1}) \frac{F_{N-1} + F_N}{2}$$

Figure 5 — Force–deflection curve for lateral loading

4.4.3 Vertical loading

4.4.3.1 After removal of the lateral load, a vertical load shall be applied to the top of the ROPS using a 250 mm wide beam (see Figure 6).

4.4.3.2 For ROPS with a two-post system and ROPS with more than two posts, the vertical load shall be applied in the same plane as the lateral loading.

4.4.3.3 For machinery with a reversible operator's position, the load shall be applied midway between the two seat index points.

Dimensions in millimetres

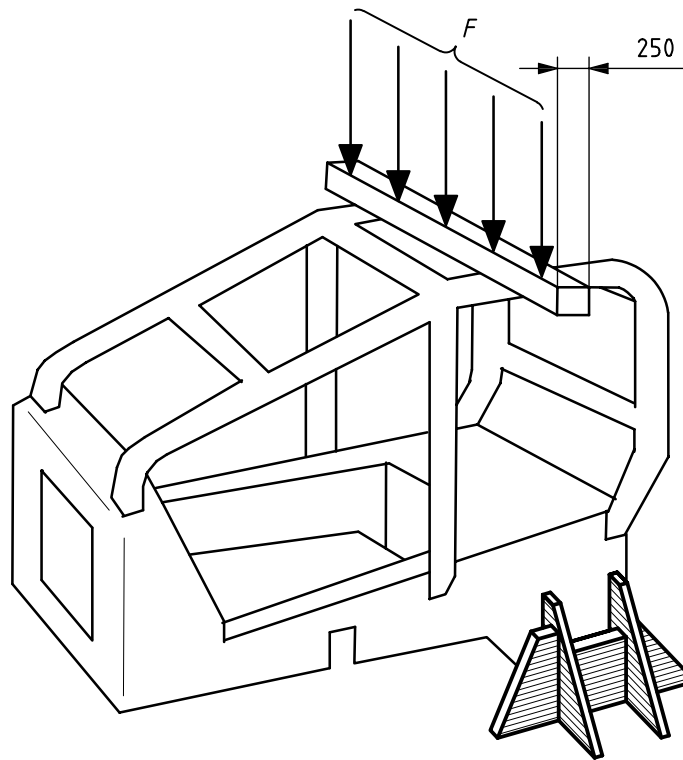
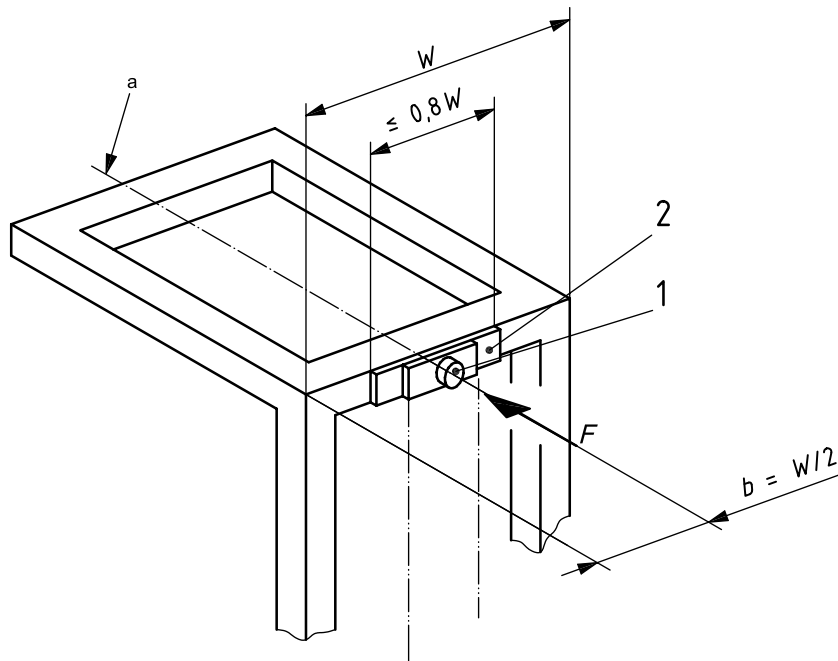

Figure 6 — Vertical load distribution and loading

4.4.4 Longitudinal loading

4.4.4.1 After removal of the vertical load, a longitudinal load shall be applied to the upper structural members of the ROPS along the longitudinal centreline of the ROPS. It shall be applied at the deformed location of the originally established point, since the lateral (and vertical) loading of the ROPS is likely to result in permanent deformation of the structure. The originally established point is determined by the location of the load distributor and socket prior to any test being performed on the structure.

4.4.4.2 The load distribution device may span the width in cases where no rear (or front) cross-member exists. In all other cases, the device shall not distribute the load over a length greater than 80 % of the width, W , of the ROPS (see Figure 7). No ROPS, straight or curved, should have its strength affected by the load distributor.



Key

- 1 socket
- 2 load distributor

NOTE 1 The load distributor and socket are to prevent local penetration and to hold the end of the load-generating device.

NOTE 2 Typical, but not mandatory, layout.

^a Parallel to longitudinal centreline of machine.

Figure 7 — Longitudinal loading

4.4.4.3 The direction of loading (fore or aft) shall be selected to place the most severe requirements on the ROPS/machine-frame assembly. The initial direction of loading shall be horizontal and parallel to the original longitudinal centreline of the machine. Some additional factors to consider in deciding on the direction to apply the longitudinal load are

- a) the location of the ROPS relative to the DLV and the effect that longitudinal deflection of the ROPS would have on providing crush protection for the operator,
- b) machine characteristics (e.g. other structural members of the machine which may resist longitudinal deflection of the ROPS) that can limit direction of the longitudinal component of loading on the ROPS, and
- c) experience which may indicate the possibility of longitudinal tipping or the tendency of a particular classification of machine to skew as it rotates about a longitudinal axis during an actual roll-over.

4.4.4.4 The rate of deflection shall be such that the loading may be considered static (see 4.4.2.6). This loading is to continue until the ROPS has achieved the force requirement or requirements.

5 Performance requirements

5.1 General

During each test, no part of the ROPS shall enter the DLV of the operator (see ISO 3164). For machinery with a reversible operator's position, the load shall be applied midway between the two seat index points. Deformation of the ROPS shall not allow the simulated ground plane to enter this zone.

5.2 Force, energy and load requirements

5.2.1 These requirements shall be met within the deflection or deflections permitted by the deflection-limiting volume in accordance with ISO 3164. The requirements are related to the machine mass, m .

5.2.2 The lateral load force attained shall be at least that specified for the corresponding machine type in Table 3.

The force and energy requirements need not be attained simultaneously. If the required force is attained or exceeded before the energy requirement is met, the force may decrease, but shall again attain the required force when the energy is achieved or exceeded.

Table 3 — Minimum force attained during lateral loading

Machine type	Force F N
Wheeled forestry machines ^a	$F = 60\,000 \left(\frac{m}{10\,000} \right)^{1,2}$
Tracked forestry machines	$F = 70\,000 \left(\frac{m}{10\,000} \right)^{1,2}$
^a Includes machines where tracks can be mounted on rubber tyres as optional equipment.	

5.2.3 The energy absorbed during lateral loading shall be at least that specified for the corresponding machine type in Table 4.

Table 4 — Minimum energy absorbed during lateral loading

Machine type	Energy U J
Wheeled forestry machines ^a	$U = 12\,500 \left(\frac{m}{10\,000} \right)^{1,25}$
Tracked forestry machines	$U = 13\,000 \left(\frac{m}{10\,000} \right)^{1,25}$
^a Includes machines where tracks can be mounted on rubber tyres as optional equipment.	

5.2.4 After removal of the lateral load, the ROPS/machine assembly shall support a vertical load of $20 \times m$, expressed in newtons, for a period of 5 min or until any deformation has ceased, whichever is the shorter.

5.2.5 The longitudinal load force attained shall be at least that specified for the corresponding machine type in Table 5.

Table 5 — Minimum force attained during longitudinal loading

Machine type	Force <i>F</i> N
Wheeled forestry machines ^a	$F = 48\,000 \left(\frac{m}{10\,000} \right)^{1,2}$
Tracked forestry machines	$F = 56\,000 \left(\frac{m}{10\,000} \right)^{1,2}$
^a Includes machines where tracks can be mounted on rubber tyres as optional equipment.	

5.3 Temperature and material requirements

5.3.1 General

The laboratory evaluations should be performed with all ROPS and machine-frame members soaked to a temperature of – 18 °C or below. If the evaluations are not performed at this temperature, the minimum material requirements in 5.3.2 and 5.3.3 shall be met.

5.3.2 Bolts and nuts

Bolts and nuts used to attach the ROPS to the machine frame and to connect structural parts of the ROPS shall be

- property class 8.8, 9.8 or 10.9 for bolts (see ISO 898-1), and
- property class 8, 9 or 10 for nuts (see ISO 898-2).

5.3.3 Impact strength

The structural members of the ROPS and the mounts which attach it to the machine shall be made of steel having a Charpy V-notch impact strength in accordance with Table 6.

Specimens are to be longitudinal and taken from flat stock, tubular or structural sections before forming or welding for use in the ROPS. Specimens from tubular or structural sections shall be taken from the middle of the side of greatest dimensions and shall not include welds (see ISO 148-1).

6 Reporting results

The results of the tests shall be reported using a test report in accordance with Annex A.

Table 6 — Minimum Charpy V-notch impact strength

Specimen size mm	Energy	
	– 30 °C J	– 20 °C J ^b
10 × 10 ^a	11	27,5
10 × 9	10	25
10 × 8	9,5	24
10 × 7,5 ^a	9,5	24
10 × 7	9	22,5
10 × 6,7	8,5	21
10 × 6	8	20
10 × 5 ^a	7,5	19
10 × 4	7	17,5
10 × 3,3	6	15
10 × 3	6	15

^a Indicates preferred size. Specimen size shall be no less than the largest preferred size that the material will permit.

^b The energy requirement at the temperature of – 20 °C is 2,5 times the value specified for – 30 °C. Other factors affect impact energy strength, i.e. direction of rolling, yield strength, grain orientation and welding. These factors shall be considered when selecting and using a steel.

Annex A
(normative)

Test report for ISO 8082-1

Machine identification

Type:

Manufacturer:

Model:

Machine frame part number:

Wheeled/track-laying machine:

ROPS identification

Manufacturer:

Model:

Serial number:

ROPS part number:

Manufacturer-supplied information

Machine mass: kg

Location of DLV:

Criteria

Lateral load force: N

Lateral load energy: J

Vertical load: N

Longitudinal load force: N

Test results

The following force and energy levels were achieved or exceeded without penetration by the ROPS structural member or simulated ground planes (where applicable) into the DLV.

Lateral loading

Force attained after energy requirement achieved or exceeded: N

Absorbed energy attained: J

Vertical loading

Force attained: N

Longitudinal loading

Force attained: N

Temperature and materials

Test performed with ROPS and machine frame soaked to °C

The following is to be completed only if this temperature is above – 18 °C.

The Charpy V-notch impact strength requirements for ROPS structural metallic members were tested on a specimen of size mm × mm.

Absorbed energy: J

Nut property class:

Bolt property class:

Attestation

The minimum performance requirements of ISO 8082-1 were met in this test for a maximum machine mass of kg, including the following attachments, equipment and tools:

.....
.....
.....

Date of test:

Name and address of test facility:

.....

Test engineer:

Date/number of test report:

Bibliography

- [1] ISO 3411, *Earth-moving machinery — Physical dimensions of operators and minimum operator space envelope*
- [2] ISO 3471, *Earth-moving machinery — Roll-over protective structures — Laboratory tests and performance requirements*
- [3] ISO 8083, *Machinery for forestry — Falling-object protective structures (FOPS) — Laboratory tests and performance requirements*
- [4] ISO 8084, *Machinery for forestry — Operator protective structures — Laboratory tests and performance requirements*

BSI - British Standards Institution

BSI is the independent national body responsible for preparing British Standards. It presents the UK view on standards in Europe and at the international level. It is incorporated by Royal Charter.

Revisions

British Standards are updated by amendment or revision. Users of British Standards should make sure that they possess the latest amendments or editions.

It is the constant aim of BSI to improve the quality of our products and services. We would be grateful if anyone finding an inaccuracy or ambiguity while using this British Standard would inform the Secretary of the technical committee responsible, the identity of which can be found on the inside front cover. Tel: +44 (0)20 8996 9000. Fax: +44 (0)20 8996 7400.

BSI offers members an individual updating service called PLUS which ensures that subscribers automatically receive the latest editions of standards.

Buying standards

Orders for all BSI, international and foreign standards publications should be addressed to Customer Services. Tel: +44 (0)20 8996 9001. Fax: +44 (0)20 8996 7001 Email: orders@bsigroup.com You may also buy directly using a debit/credit card from the BSI Shop on the Website <http://www.bsigroup.com/shop>

In response to orders for international standards, it is BSI policy to supply the BSI implementation of those that have been published as British Standards, unless otherwise requested.

Information on standards

BSI provides a wide range of information on national, European and international standards through its Library and its Technical Help to Exporters Service. Various BSI electronic information services are also available which give details on all its products and services. Contact Information Centre. Tel: +44 (0)20 8996 7111 Fax: +44 (0)20 8996 7048 Email: info@bsigroup.com

Subscribing members of BSI are kept up to date with standards developments and receive substantial discounts on the purchase price of standards. For details of these and other benefits contact Membership Administration. Tel: +44 (0)20 8996 7002 Fax: +44 (0)20 8996 7001 Email: membership@bsigroup.com

Information regarding online access to British Standards via British Standards Online can be found at <http://www.bsigroup.com/BSOL>

Further information about BSI is available on the BSI website at <http://www.bsigroup.com>

Copyright

Copyright subsists in all BSI publications. BSI also holds the copyright, in the UK, of the publications of the international standardization bodies. Except as permitted under the Copyright, Designs and Patents Act 1988 no extract may be reproduced, stored in a retrieval system or transmitted in any form or by any means – electronic, photocopying, recording or otherwise – without prior written permission from BSI.

This does not preclude the free use, in the course of implementing the standard, of necessary details such as symbols, and size, type or grade designations. If these details are to be used for any other purpose than implementation then the prior written permission of BSI must be obtained.

Details and advice can be obtained from the Copyright and Licensing Manager. Tel: +44 (0)20 8996 7070 Email: copyright@bsigroup.com