

Textiles — Test method for assessing the smoothness appearance of seams in fabrics after cleansing

ICS 59.080.30

National foreword

This British Standard is the UK implementation of ISO 7770:2009. It supersedes BS ISO 7770:2006 which is withdrawn.

The UK participation in its preparation was entrusted to Technical Committee TCI/82, Textiles care labelling, dry cleaning, domestic laundering and drying.

A list of organizations represented on this committee can be obtained on request to its secretary.

This publication does not purport to include all the necessary provisions of a contract. Users are responsible for its correct application.

Compliance with a British Standard cannot confer immunity from legal obligations.

This British Standard was published under the authority of the Standards Policy and Strategy Committee on 30 June 2009.

© BSI 2009

ISBN 978 0 580 62718 7

Amendments/corrigenda issued since publication

Date	Comments

INTERNATIONAL STANDARD

ISO
7770

Third edition
2009-05-15

Textiles — Test method for assessing the smoothness appearance of seams in fabrics after cleansing

*Textiles — Méthode d'essai pour l'évaluation de la régularité d'aspect
des coutures sur les étoffes après nettoyage*



Reference number
ISO 7770:2009(E)

PDF disclaimer

This PDF file may contain embedded typefaces. In accordance with Adobe's licensing policy, this file may be printed or viewed but shall not be edited unless the typefaces which are embedded are licensed to and installed on the computer performing the editing. In downloading this file, parties accept therein the responsibility of not infringing Adobe's licensing policy. The ISO Central Secretariat accepts no liability in this area.

Adobe is a trademark of Adobe Systems Incorporated.

Details of the software products used to create this PDF file can be found in the General Info relative to the file; the PDF-creation parameters were optimized for printing. Every care has been taken to ensure that the file is suitable for use by ISO member bodies. In the unlikely event that a problem relating to it is found, please inform the Central Secretariat at the address given below.



COPYRIGHT PROTECTED DOCUMENT

© ISO 2009

All rights reserved. Unless otherwise specified, no part of this publication may be reproduced or utilized in any form or by any means, electronic or mechanical, including photocopying and microfilm, without permission in writing from either ISO at the address below or ISO's member body in the country of the requester.

ISO copyright office
Case postale 56 • CH-1211 Geneva 20
Tel. + 41 22 749 01 11
Fax + 41 22 749 09 47
E-mail copyright@iso.org
Web www.iso.org

Published in Switzerland

Contents

Page

Foreword.....	iv
1 Scope	1
2 Normative references	1
3 Principle	1
4 Apparatus	1
5 Test specimens	2
6 Procedure	2
7 Expression of results	3
8 Test report	3
Annex A (informative) Digital description of the ISO seam-pucker replicas.....	9

Foreword

ISO (the International Organization for Standardization) is a worldwide federation of national standards bodies (ISO member bodies). The work of preparing International Standards is normally carried out through ISO technical committees. Each member body interested in a subject for which a technical committee has been established has the right to be represented on that committee. International organizations, governmental and non-governmental, in liaison with ISO, also take part in the work. ISO collaborates closely with the International Electrotechnical Commission (IEC) on all matters of electrotechnical standardization.

International Standards are drafted in accordance with the rules given in the ISO/IEC Directives, Part 2.

The main task of technical committees is to prepare International Standards. Draft International Standards adopted by the technical committees are circulated to the member bodies for voting. Publication as an International Standard requires approval by at least 75 % of the member bodies casting a vote.

Attention is drawn to the possibility that some of the elements of this document may be the subject of patent rights. ISO shall not be held responsible for identifying any or all such patent rights.

ISO 7770 was prepared by Technical Committee ISO/TC 38, *Textiles*, Subcommittee SC 2, *Cleansing, finishing and water resistance tests*.

This third edition cancels and replaces the second edition (ISO 7770:2006), of which it constitutes a minor revision. It incorporates ISO 7770:2006/DAmD.1:2008 to add Annex A (informative).

Textiles — Test method for assessing the smoothness appearance of seams in fabrics after cleansing

1 Scope

This International Standard specifies a test method for evaluating the smoothness appearance of seams in fabrics, after one or several cleansing treatments. A seaming technique is not included, since the purpose is to evaluate existing seams.

This method has been developed for use primarily with type B domestic washing machines, as defined in ISO 6330, in the cleansing process. However, it may be possible to use it with type A machines, as defined in the same International Standard.

NOTE A digital description of the ISO seam-pucker replicas is given in Annex A.

2 Normative references

The following referenced documents are indispensable for the application of this document. For dated references, only the edition cited applies. For undated references, the latest edition of the referenced document (including any amendments) applies.

ISO 105-A03, *Textiles — Tests for colour fastness — Part A03: Grey scale for assessing staining*

ISO 139, *Textiles — Standard atmospheres for conditioning and testing*

ISO 3175 (all parts), *Textiles — Professional care, drycleaning and wetcleaning of fabrics and garments*

ISO 6330, *Textiles — Domestic washing and drying procedures for textile testing*

3 Principle

3.1 Seamed fabric specimens are subjected to procedures simulating cleansing practices. One of the washing and drying procedures specified in ISO 6330 or one of the professional procedures specified in ISO 3175 is used, as agreed between the interested parties.

3.2 The specimens are compared visually with photographic or 3D plastic replica standards under specified illumination.

4 Apparatus

4.1 **Washing and drying apparatus**, as specified in ISO 6330, or **professional care apparatus**, as specified in ISO 3175.

4.2 **Steam or dry iron**, with appropriate fabric temperature settings.

4.3 Lighting.

The evaluation area shall be a darkened room, using the lighting and viewing arrangement shown in Figure 1 and comprising the following items. Lamp dimensions should be chosen to extend beyond the overall surface of a test specimen and replicas, when used for the assessment.

4.3.1 Two CW (cool white) fluorescent lamps, without baffle or glass, a minimum of 2 m in length each, placed side by side.

4.3.2 One white enamel reflector, without baffle or glass.

4.3.3 One thick plywood viewing board, painted grey to match the No. 2 rating on the grey scale for assessing staining specified in ISO 105-A03.

4.4 Photographic standards, prepared for evaluating seam appearance (single and double needle stitching) as shown in Figures 2 and 3 ¹⁾.

4.5 Three-dimensional (3D) plastic replica standards, prepared for evaluating seam appearance (single and double needle stitching), as shown in Figures 4 and 5 ²⁾.

5 Test specimens

Prepare three test specimens, each measuring 38 cm × 38 cm and pinked to prevent fraying and each prepared in an identical manner with a seam inserted through the middle of the length direction of the fabric. If the fabric is wrinkled, it may be smoothed by appropriate ironing prior to testing. Care shall be taken to avoid altering the quality of the seam itself.

If excessive fraying is anticipated, specimens shall be stitched loosely 1 cm in from the edges, using dimensionally stable thread.

6 Procedure

6.1 Treat each specimen in accordance with one of the procedures specified in ISO 6330 or ISO 3175, as agreed between the interested parties.

6.2 If required, repeat the selected treatment four times, to give a total of five cycles.

6.3 Condition the test specimens for a minimum of 4 h and maximum of 24 h according to ISO 139, by hanging each specimen by two corners with the seam in a vertical position or, alternatively, using full-width clamps.

6.4 For the evaluation, carry out steps 6.4.1 to 6.4.5.

6.4.1 Three observers shall rate each treated test specimen independently.

1) The standards shown in Figures 2 and 3 are for illustrative purposes only. The standards may be obtained from AATCC Technical Center, One Davis Drive, P.O. Box 12215, Research Triangle Park, North Carolina 27709-2215, USA; Tel: +1 919-549-8141; Fax: +1 919-549-8933; <http://www.aatcc.org/>. This information is given for the convenience of the users of this document and does not constitute an endorsement by ISO of the product named. Equivalent products may be used if they can be shown to lead to the same results.

2) The standards shown in Figures 4 and 5 are for illustrative purposes only. The standards may be obtained from Japanese Standards Association (JSA), 4-1-24 Akasaka, Minato-Ku, Tokyo 107-8440 Japan; Tel: +81-3-3583-8002; Fax: +81-3-3583-0462; <http://www.jsa.or.jp/>. This information is given for the convenience of the users of this document and does not constitute an endorsement by ISO of the product named. Equivalent products may be used if they can be shown to lead to the same results.

6.4.2 Mount the test specimen on the viewing board (4.3.3) as illustrated in Figure 1, with the seam in the vertical direction. Place the appropriate photographic standards (4.4) (single or double needle) alongside or the appropriate 3D plastic replica standards (4.5) (single or double needle) on either side of the test specimen to facilitate comparative rating. (See Note, Figure 1.)

The overhead fluorescent light (4.3.1) shall be the only light source for the viewing board, and all other lights in the room shall be turned off. It has been the experience of many observers that the light reflected from the side walls near the viewing board can interfere with the rating results. It is recommended that the side walls be painted black or that blackout curtains be mounted on either side of the viewing board to eliminate the reflective interference.

6.4.3 The observer shall stand directly in front of the replica, 1,2 m away from the board. It has been found that normal variations in the height of the observer above and below the arbitrary 1,5 m eye level have no significant effect on the rating given.

6.4.4 Confine observations to the area influenced by the seam and disregard the appearance of the fabric itself. Assign the number of the photographic standard or assign a grade midway between the JIS three-dimensional plastic replica standards that most nearly match the appearance of the seam in the test specimen (see Figures 2, 3, 4 and 5 and Table 1).

Standard 5 represents the best level of seam appearance while Standard 1 represents the poorest level of seam appearance.

6.4.5 Similarly, the observer shall independently rate each of the other two test specimens. The other two observers shall proceed in the same manner, assigning ratings independently.

7 Expression of results

Average the nine observations made by the three observers on the set of three test specimens. Report the average to the nearest half of a rating.

Table 1 — Seam appearance ratings

Class	Seam appearance
5	Equivalent to Standard 5
4,5	Midway between Standard 5 and Standard 4
4	Equivalent to Standard 4
3,5	Midway between Standard 4 and Standard 3
3	Equivalent to Standard 3
2,5	Midway between Standard 3 and Standard 2
2	Equivalent to Standard 2
1,5	Midway between Standard 2 and Standard 1
1	Equivalent to or worse than Standard 1

8 Test report

The test report shall include the following information:

- a) a reference to this International Standard (ISO 7770:2009);
- b) details of the sample evaluated;

- c) details of the cleansing procedures used, as specified in ISO 6330;
- d) the number of cleansing cycles used;
- e) the standard replica used;
- f) the seam appearance rating as calculated according to Clause 7 and expressed according to Table 1;
- g) details of any deviation from the specified procedure.

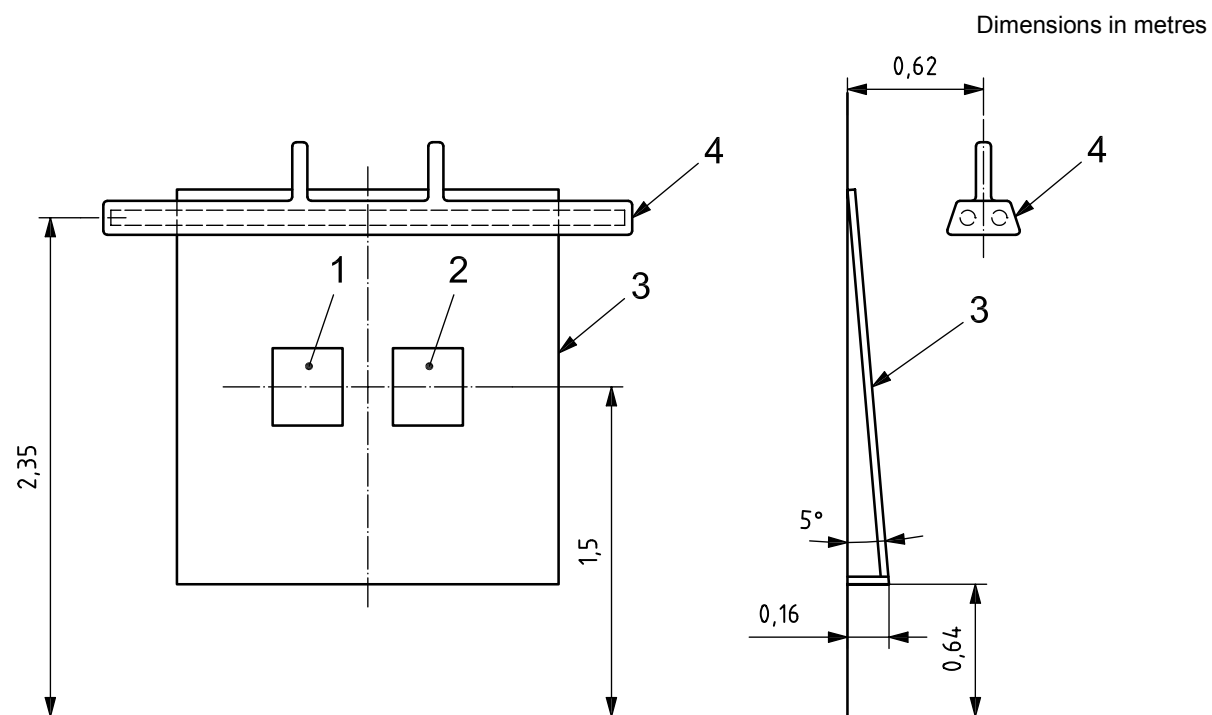

Key

- 1 standard
- 2 test specimen
- 3 board for viewing
- 4 example of fluorescent lamp placement

NOTE When using 3D plastic replica standards, a test specimen is placed in the middle and 3D replicas are placed on either side.

Figure 1 — Lighting equipment for viewing test specimens

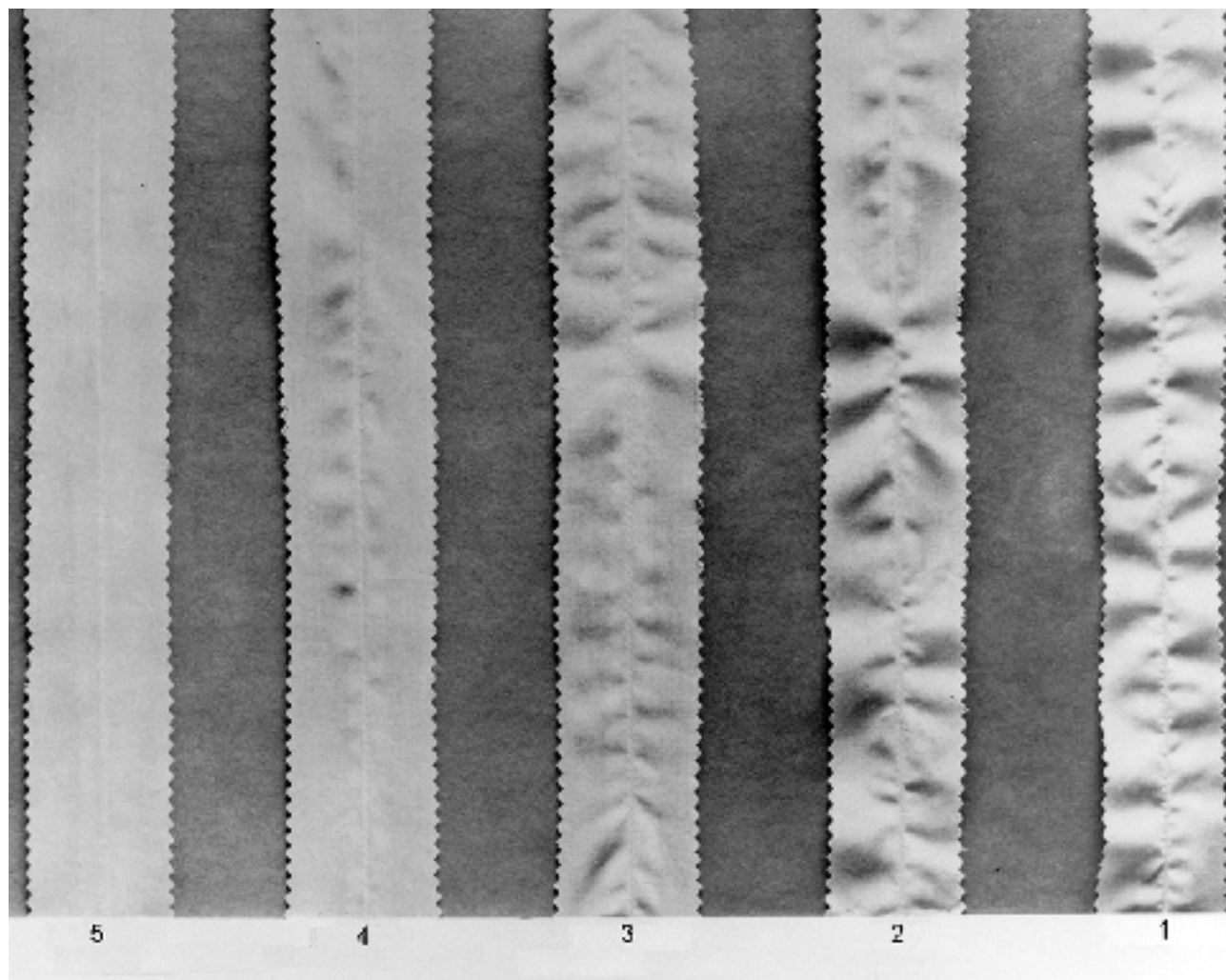

Figure 2 — Photographic comparative ratings for single needle seams

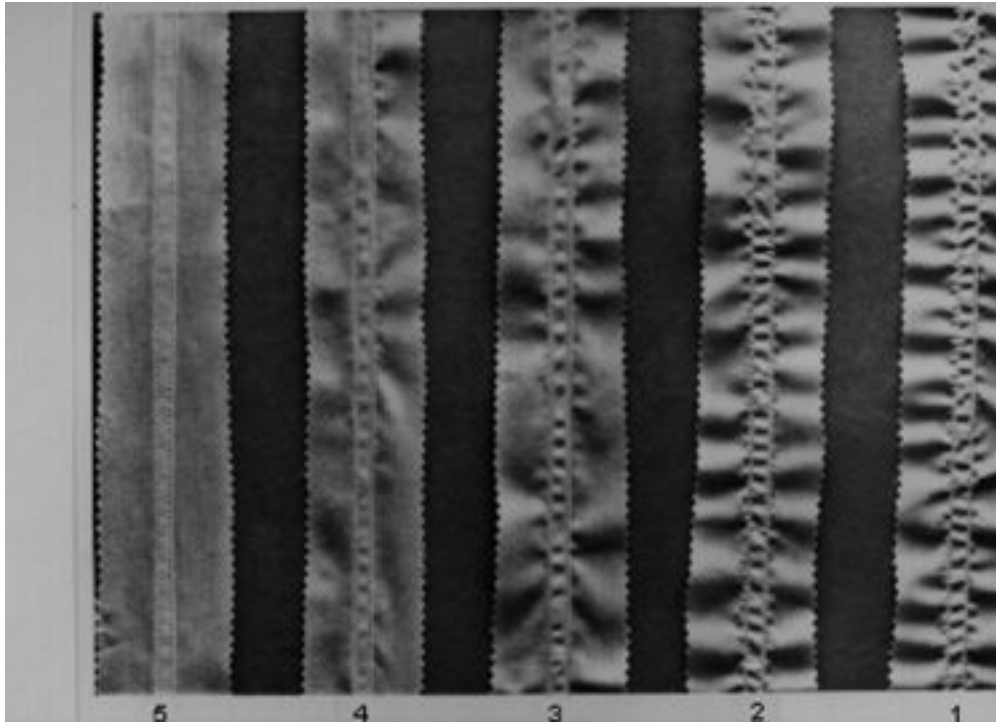

Figure 3 — Photographic comparative ratings for double needle seams

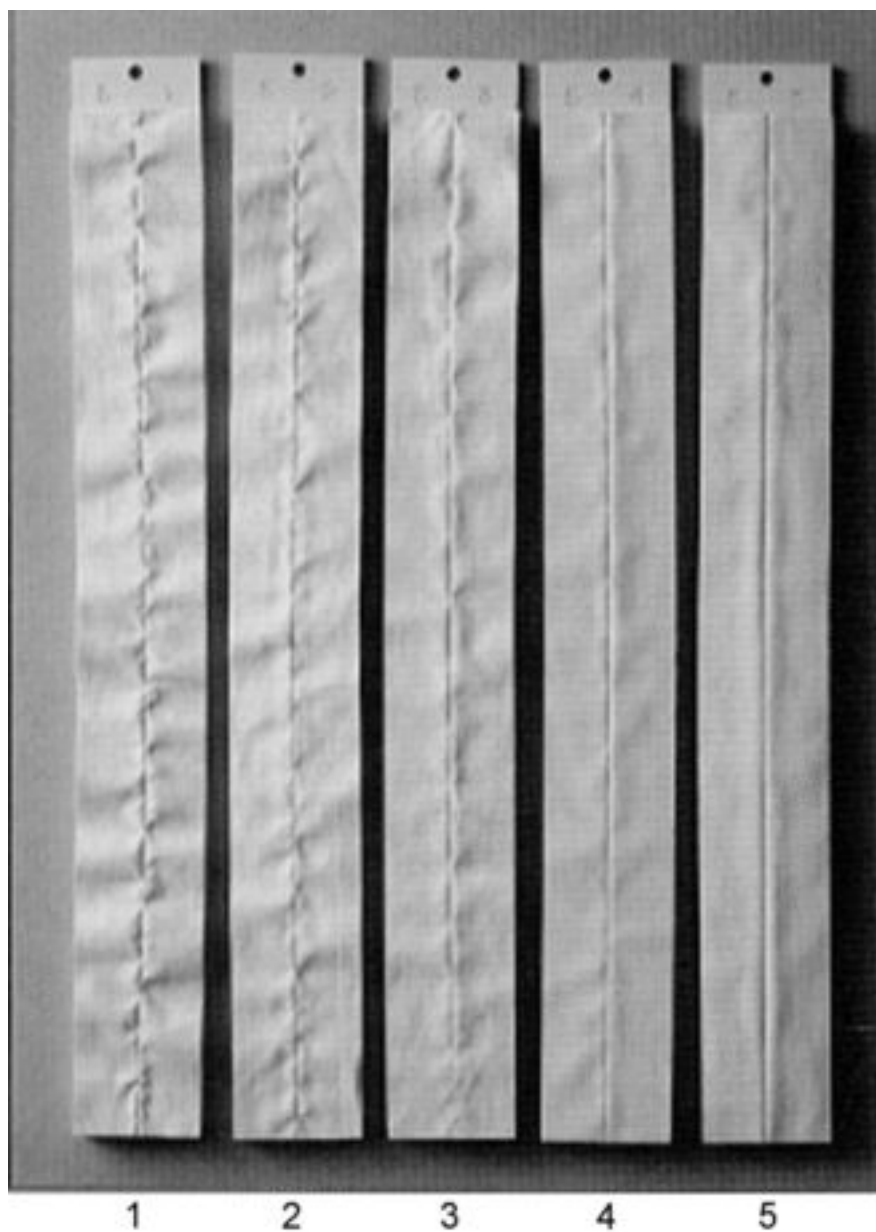

Figure 4 — Solid replica comparative ratings for single needle seams

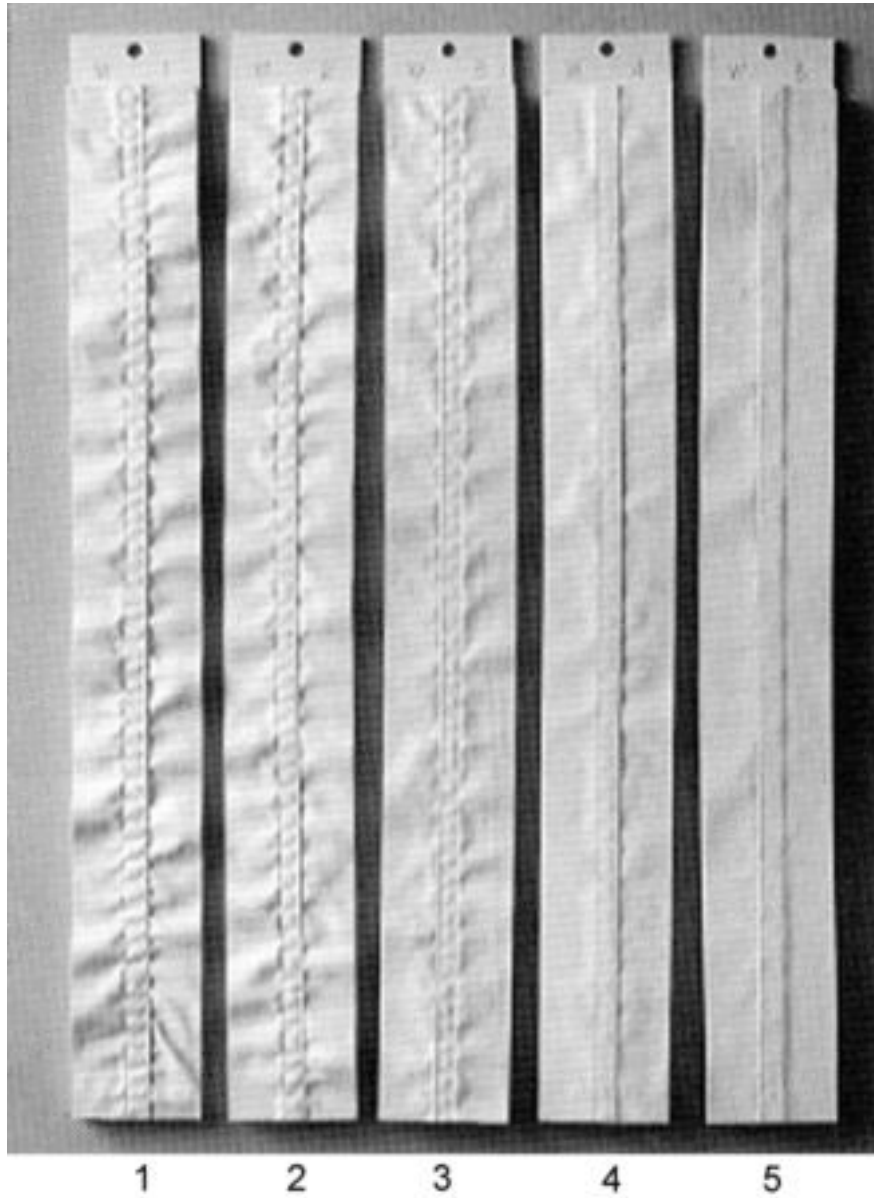

Figure 5 — Solid replica comparative ratings for double needle seams

Annex A (informative)

Digital description of the ISO seam-pucker replicas

A.1 Introduction

This annex provides the digital description of three-dimensional (3D) replicas. The data are not intended to be used to assess specimens. When assessing specimens, the 3D replicas are to be used.

A.2 Processes of measurement and analysis

A.2.1 A 3-dimensional scanning system was used to measure digital images of ISO seam-pucker replicas as shown in Figure A.1. Specifications for the scanning system are shown in Table A.1.

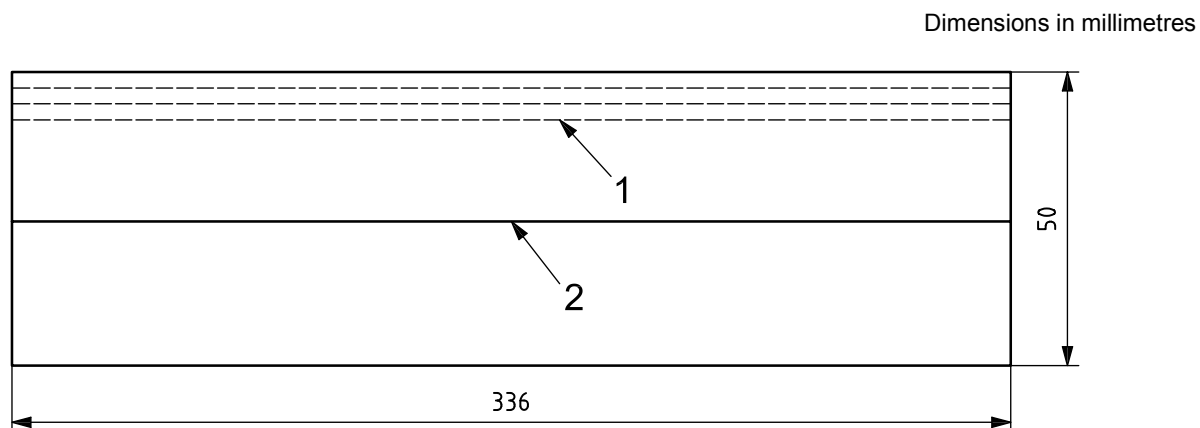

Figure A.1 — 3-Dimensional scanning system

Table A.1 — Specification of the 3-dimensional scanning system

Camera	1 024 × 768 pixels, black and white (B/W)
Special pattern	Structural beam by halogen lamp
Adjustment of focus	Using the laser-point light source
Measurement time	Approximately 70 s to 80 s
Resolution	± 0,05 mm

A.2.2 The measuring area is shown in Figure A.2.



Key

- 1 measuring lines
- 2 seam line

Figure A.2 — Measuring area of seam-pucker replica

A.2.3 A geometric shape of each standard replica is measured using a 3-dimensional laser scanning system in a parallel direction with the seam line of the replicas at an interval of 1 mm. 43 lines with 1 mm intervals are selected to analyse the replicas precisely. The measuring point intervals along each line are the same as the line intervals: 1 mm. The number of measuring points along each line is determined by the interval.

To analyse the replicas, six shape parameters that have an influence on the grade of replica were defined. These parameters are mean values of heights, maximum values of heights, variation of heights, mean values of height frequency, maximum values of height frequency and variation of height frequency. For each region, six parameters can be obtained.

A.3 Analysis of single seam pucker with 1 mm interval measurements

A.3.1 Measured images of single seam-pucker replicas

Figure A.3 shows measured images of single seam-pucker replicas using a 3-dimensional scanning system at intervals of 1 mm.

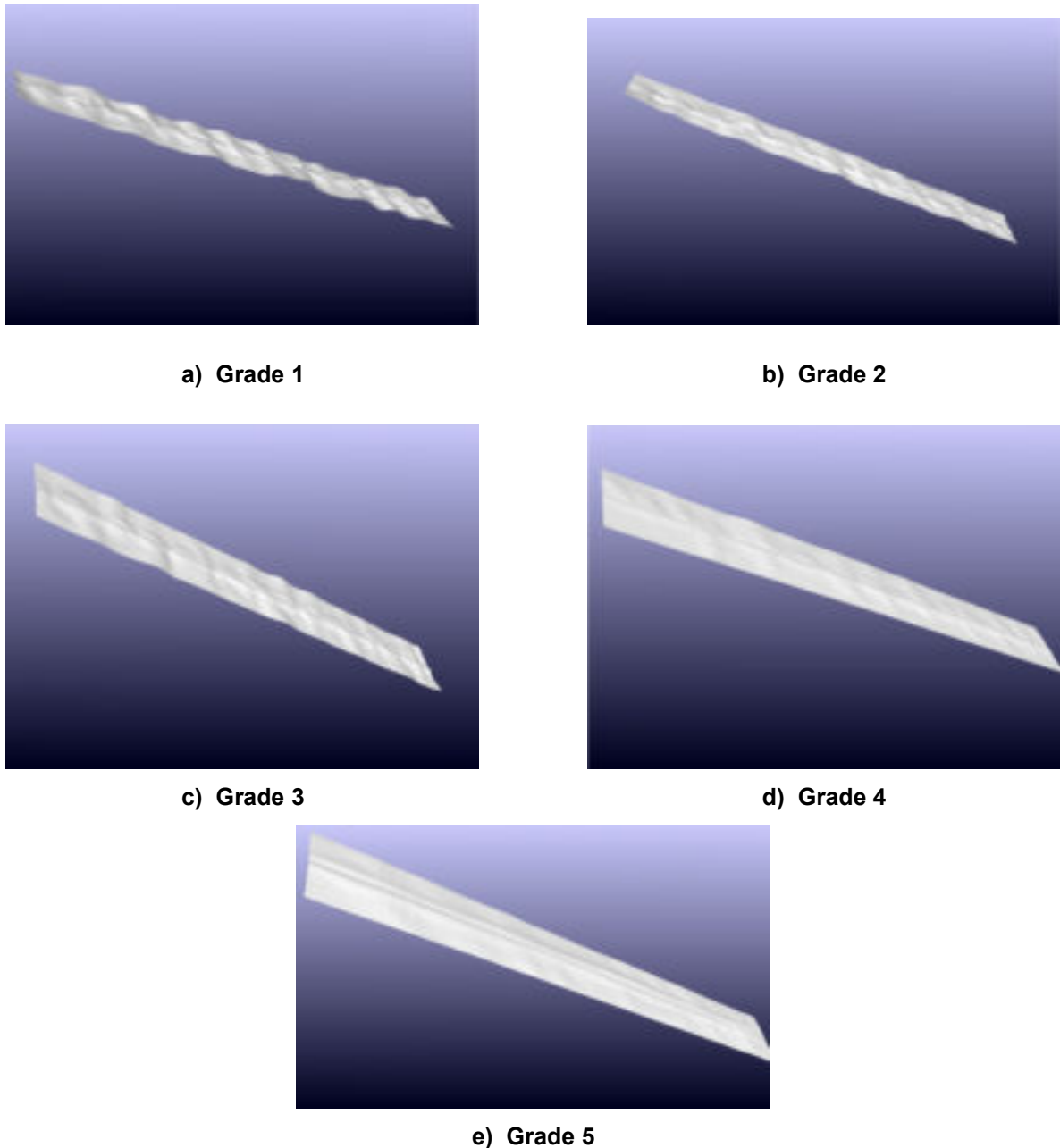

Figure A.3 — Measured images of seam-pucker replicas

A.3.2 Analysis of parameters

A.3.2.1 Mean value of height (\bar{h})

Figure A.4 shows the relationship between the single seam-pucker grade and the mean value of height. An Analysis Of Variance (ANOVA) test and Tukey's method were performed to confirm differences in this

parameter between grades. From the results of the ANOVA test, the difference in grades was confirmed at the 95 % confidence level. The results of Tukey’s method indicated no significant differences between grade 1 and grade 2 and between grade 3 and grade 5.

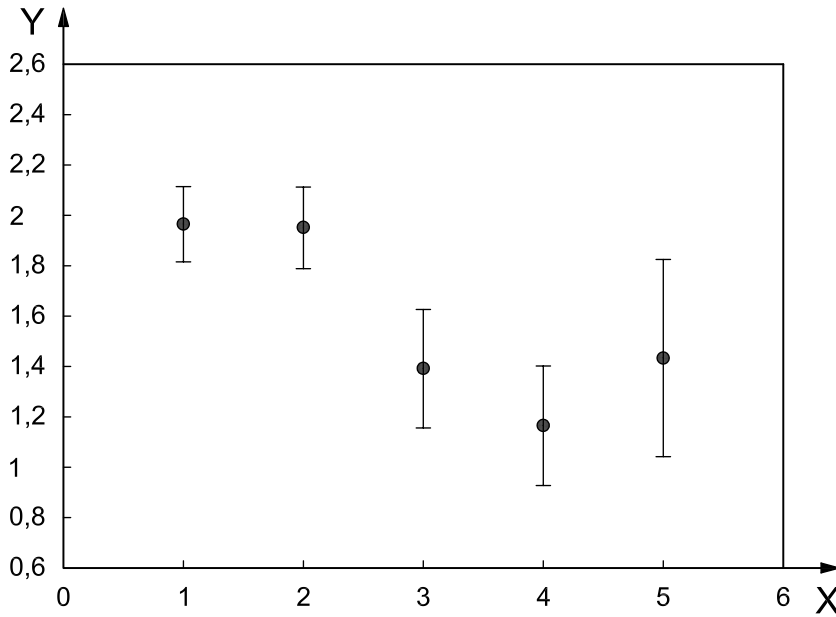

Key

X grade of single seam-pucker replica
 Y \bar{h}

Figure A.4 — Relationship between grade and mean of height

A simple regression analysis is performed to verify the apparent linear relationship between grades of replicas and the mean value of height. From the results of this analysis, the *R*-squared value is 41,70 %, as shown in Table A.2.

Table A.2 — Results of a simple regression analysis on \bar{h}

Parameter	Regression equation	<i>R</i> ²
\bar{h}	Grade = 6,56 – 2,25 × \bar{h}	41,70 %

A.3.2.2 Maximum value of height (*h*_{max})

Figure A.5 shows the relationship between the single seam-pucker grade and the maximum value of height. An ANOVA test and Tukey’s method were performed to confirm any difference in this parameter between grades. While the difference was confirmed at the 95 % confidence level with the ANOVA test, grades 1, 2, 4 and 5 were clearly not classified in a way comparable with Tukey’s method.

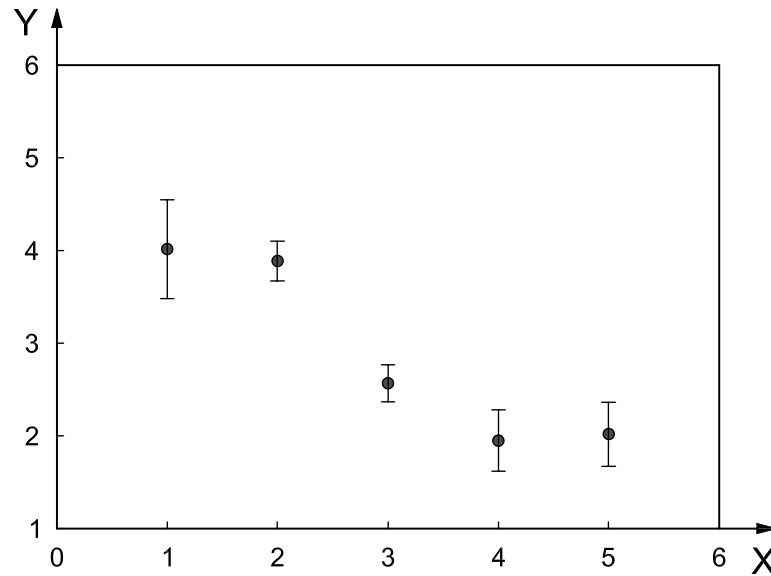

Key

X grade of single seam-pucker replica
 Y h_{\max}

Figure A.5 — Relationship between grade and maximum of height

A simple regression analysis is performed to confirm the linear relationship between the grade of replicas and the maximum value of height. From the results of this analysis, the R -squared value is 76,60 %, as shown in Table A.3.

Table A.3 — Results of a simple regression analysis on h_{\max}

Parameter	Regression equation	R^2
h_{\max}	Grade = $6,73 - 1,29 \times h_{\max}$	76,60 %

A.3.2.3 Variation of height (h_{var})

Figure A.6 shows the relationship between the single seam-pucker grade and the variation of height. An ANOVA test and Tukey's method were performed to confirm differences of variation of height between grades. The results of these analyses confirm that all grades with this parameter are clearly distinguished at the 95 % confidence level.

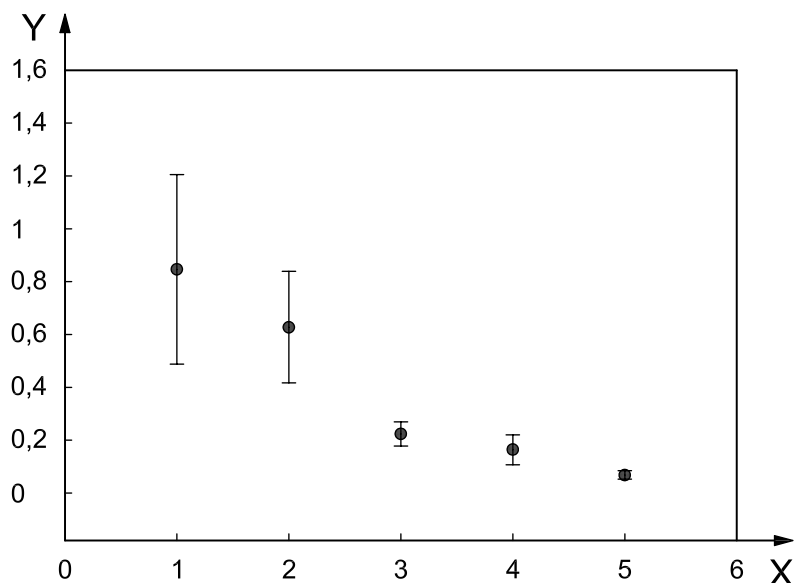

Key

X grade of single seam-pucker replica

Y h_{var}

Figure A.6 — Relationship between grade and variation of height

A simple regression analysis is performed to confirm the linear relationship between the grade of replicas and the variation value of height. From the results of this analysis, the R -squared value is 65,70 %, as shown in Table A.4.

Table A.4 — Results of a simple regression analysis on h_{var}

Parameter	Regression equation	R^2
h_{var}	Grade = $4,26 - 3,25 \times h_{var}$	65,70 %

A.3.2.4 Mean value of height frequency ($d\bar{h}$)

Figure A.7 shows the relationship between the single seam-pucker grade and the mean value of height frequency. The ANOVA test and Tukey's method were performed to confirm differences in the mean value of height frequency between grades. While the difference was confirmed at the 95 % confidence level with the ANOVA test, grades 4 and 5 are not classified at the 95 % confidence level with Tukey's method.

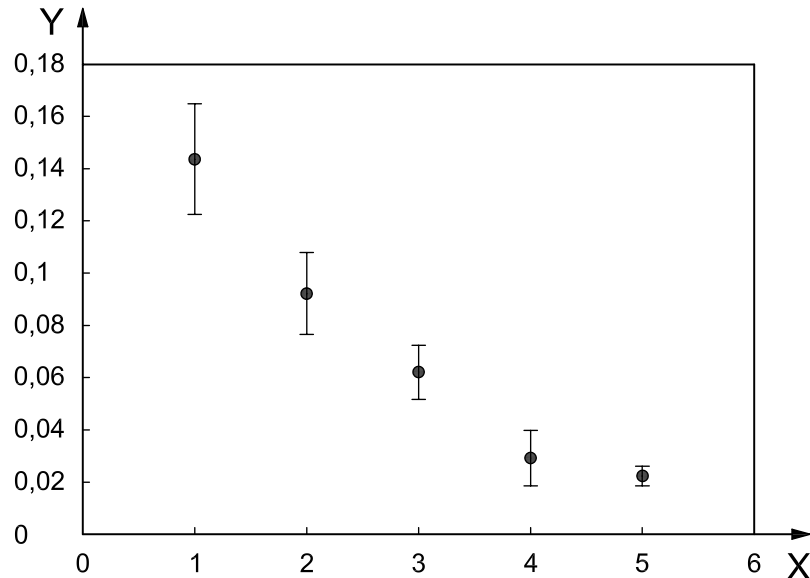

Key

X grade of single seam-pucker replica
 Y $d\bar{h}$

Figure A.7 — Relationship between grade and mean of height frequency

A simple regression analysis is performed to verify the linear relationship between grades of replicas and mean value of height frequency. From the results of this analysis, the R -squared value is 86,30 %, as shown in Table A.5.

Table A.5 — Results of a simple regression analysis on $d\bar{h}$

Parameter	Regression equation	R^2
$d\bar{h}$	Grade = $4,97 - 28,2 \times d\bar{h}$	86,30 %

A.3.2.5 Maximum value of height frequency (dh_{max})

Figure A.8 shows the relationship between the single seam-pucker grade and the maximum value of height frequency. The ANOVA test and Tukey's method were performed to confirm the difference in the maximum value of height frequency between grades. While the difference between grades was confirmed at the 95 % confidence level with the ANOVA test, grades 4 and 5 were not distinguished at the 95 % confidence level with Tukey's method.

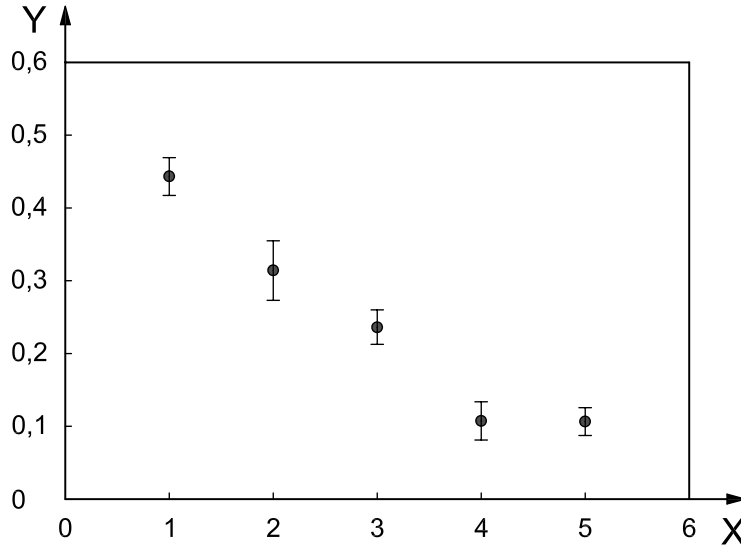

Key

- X grade of single seam-pucker replica
- Y dh_{max}

Figure A.8 — Relationship between grade and maximum of height frequency

A simple regression analysis is performed to confirm the linear relationship between grades of replicas and the maximum value of height frequency. From the results of this analysis, the R -squared value is 90,0 %, as shown in Table A.6.

Table A.6 — Results of a simple regression analysis on dh_{max}

Parameter	Regression equation	R^2
dh_{max}	Grade = 5,47 – 10,2 × dh_{max}	90,0 %

A.3.2.6 Variation of height frequency (dh_{var})

The variation value of height frequency of grade 5 is almost 0 (zero). Therefore, the relationship between this parameter and the grades could not be proven.

A.4 Multiple regression analysis

A multiple regression analysis was performed with the six parameters given in A.3.2 to produce an objective seam-pucker sample rating equation. The results are shown in Table A.7. The R -squared value is 91,60 %, which suggests that this regression equation is valid at the 95 % confidence level. Using the regression equation, the subjective and objective grades were compared. A correlation analysis was performed to verify and compare this equation. Table A.8 shows the correlation coefficient between the objective and subjective grades. Figure A.9 shows the relationship between the subjective grade and the objective single seam-pucker grade obtained from the regression equation.

Table A.7 — Results of the multiple regression analysis

Regression equation, R^2	91,60 %
----------------------------	---------

Table A.8 — Result of the correlation analysis

Correlation coefficient	0,957
--------------------------------	-------

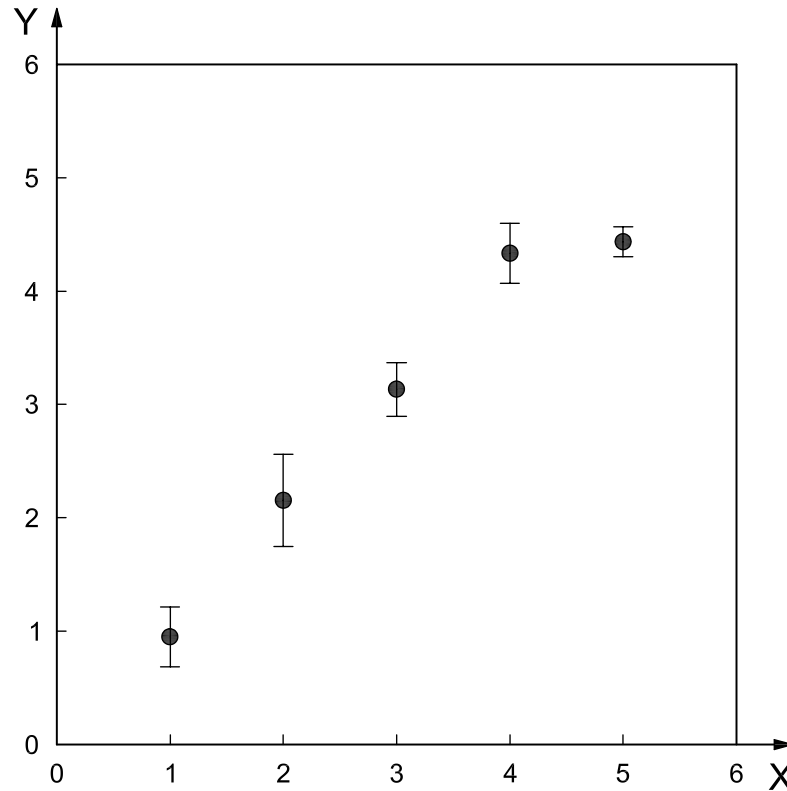

Key

- X subjective grade of single seam-pucker replica
- Y objective grade of single seam-pucker replica using regression equation

Figure A.9 — Relationship between objective and subjective evaluated grades

A.5 Conclusion

Six parameters of height and frequency distribution were determined from the images of single-seam appearance replicas, and statistical analyses were performed. ANOVA test results proved that these parameters have strong linearity with the grade of replicas. Multiple regression equations were obtained using these parameters. The results of this analysis indicated a strong linear relationship between the grades of replicas and the parameters.

The multiple regression equation with the same parameters was also used to obtain an objective seam-pucker grade. High correlations between the objective and subjective grades were proven. It can be conclusively confirmed that the current ISO seam-pucker replicas are suitable for subjective rating evaluation.

A.6 Analysis of double seam pucker with 1 mm measurements

A.6.1 Measured images of double seam-pucker replicas

Figure A.10 shows measured images of double seam-pucker replicas using a 3-dimensional scanning system at intervals of 1 mm.

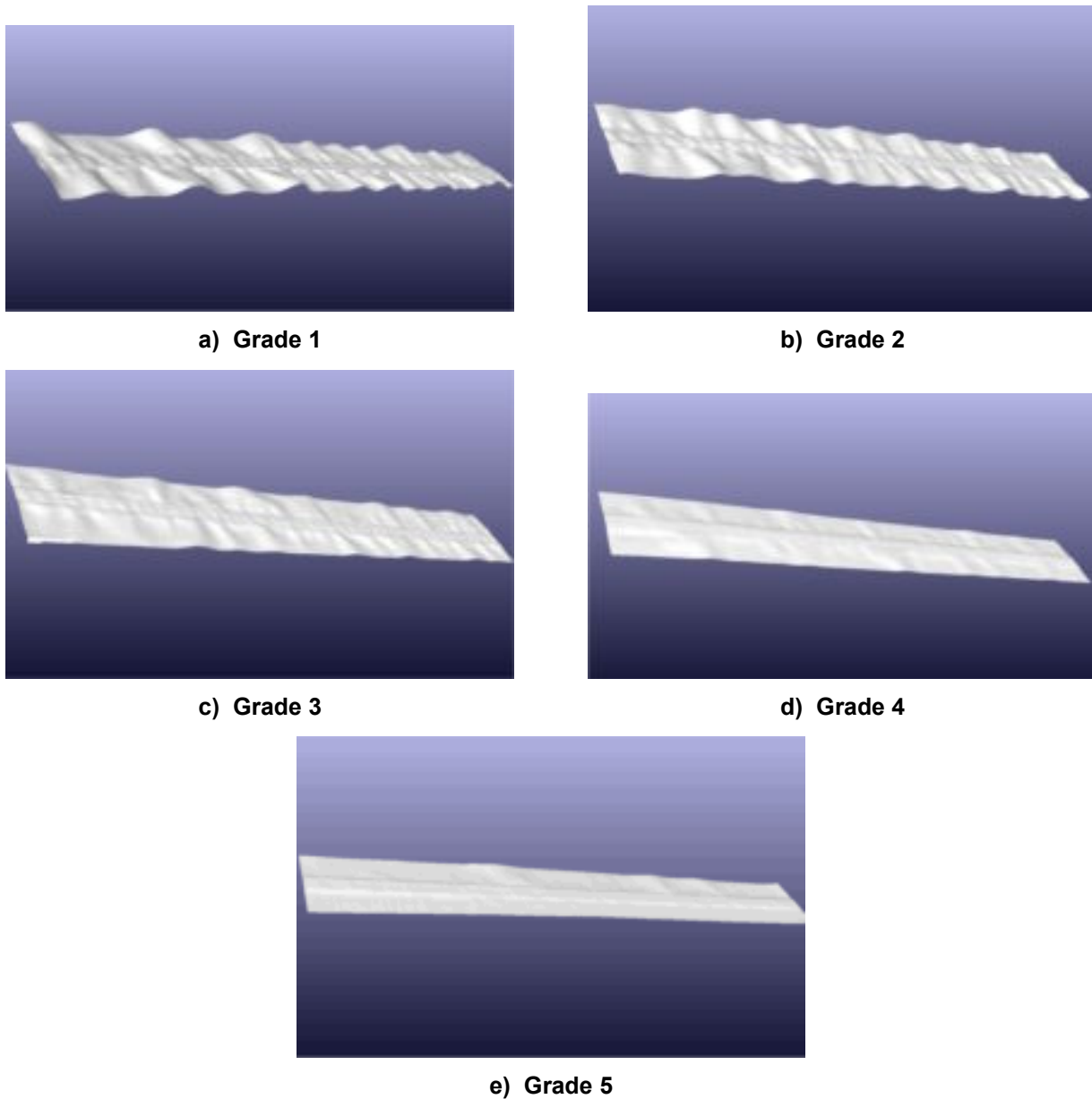
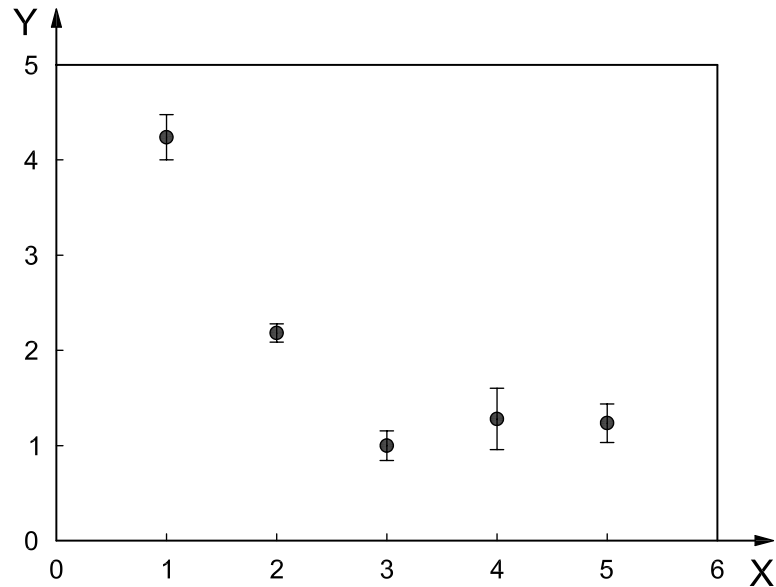

Figure A.10 — Measured images of double seam-pucker replicas

A.6.2 Analysis of parameters

A.6.2.1 Mean value of height (\bar{h})

Figure A.11 shows the relationship between the grade and the mean value of height. The ANOVA test and Tukey's method were performed to confirm differences in this parameter between grades. From the results of the ANOVA test, the differences in grades were confirmed at the 95 % confidence level. The results of Tukey's method indicated no significant differences between grade 4 and grade 5.



Key

X grade of double seam-pucker replica
 Y \bar{h}

Figure A.11 — Relationship between grade and mean of height

A simple regression analysis was performed to verify the linear relationship between grades of replicas and the mean value of height. From the results of this analysis, the *R*-squared value is 64,70 %, as shown in Table A.9.

Table A.9 — Results of a simple regression analysis on mean of height

Parameter	Regression equation	<i>R</i> ²
\bar{h}	Grade = 4,86 – 0,937 × \bar{h}	64,70 %

A.6.2.2 Maximum of height (h_{max})

Figure A.12 shows the relationship between the grade of double seam-pucker replica and the maximum value of height. The ANOVA test and Tukey's method were performed to confirm any difference in this parameter between grades. While the difference was confirmed at the 95 % confidence level with the ANOVA test, grade 3 and grade 4 are not clearly distinguished in a way comparable with Tukey's method.

A simple regression analysis was performed to verify the apparent linear relationship between the grade of replicas and the maximum value of height. From the results of this analysis, the *R*-squared value is 80,60 %, as shown in Table A.10.

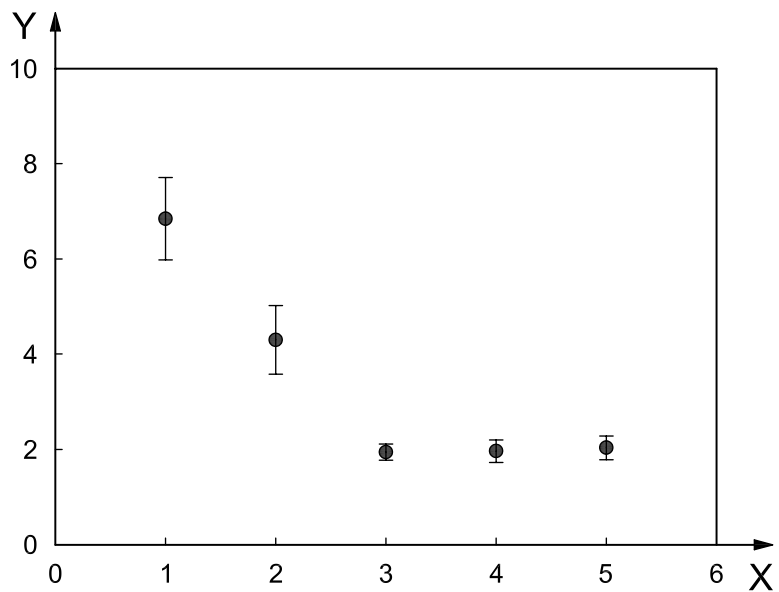

Key

X grade of double seam-pucker replica
 Y h_{max}

Figure A.12 — Relationship between grade and maximum of height

Table A.10 — Results of a simple regression analysis on maximum of height

Parameter	Regression equation	R^2
h_{max}	Grade = $4,94 - 0,594 \times h_{max}$	80,60 %

A.6.2.3 Variation of height (h_{var})

Figure A.13 shows the relationship between the grade of double seam-pucker replica and the variation of height. The ANOVA test and Tukey's method were performed to confirm differences in this parameter between grades. While the difference was confirmed at the 95 % confidence level with the ANOVA test, differences between grades 1 and 2 and differences between grades 3, 4 and 5 were not distinguished at the 95 % confidence level with Tukey's method.

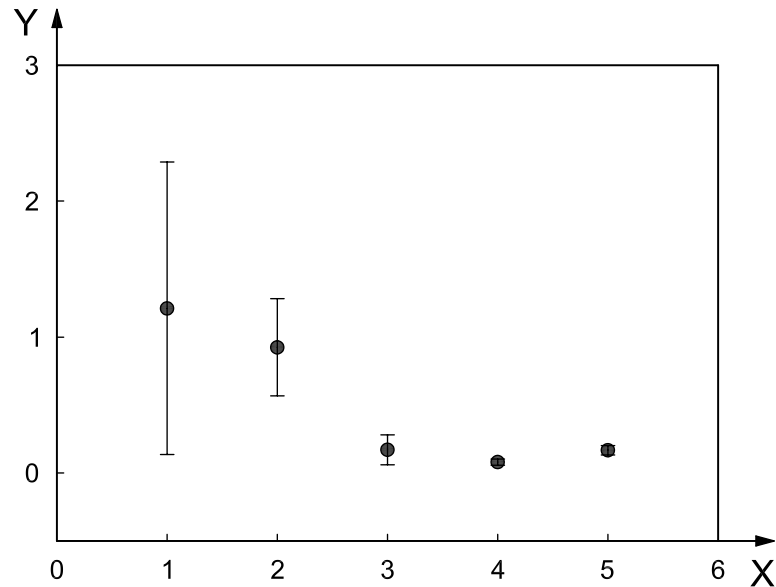

Key

X grade of double seam-pucker replica
 Y h_{var}

Figure A.13 — Relationship between grade and variation of height

A simple regression analysis was performed to verify the linear relationship between the grade and the variation of height. From the results of this analysis, the R -squared value is 36,60 %, as shown in Table A.11.

Table A.11 — Results of a simple regression analysis on variation of height

Parameter	Regression equation	R^2
h_{var}	Grade = $3,64 - 1,25 \times h_{var}$	36,60 %

A.6.2.4 Mean value of height frequency ($d\bar{h}$)

Figure A.14 shows the relationship between the grade of double seam-pucker replica and the mean value of height frequency. The ANOVA test and Tukey's method were performed to confirm differences in mean values of height frequency between grades. While the difference was confirmed at the 95 % confidence level with the ANOVA test, grades 4 and 5 are not classified at the 95 % confidence level with Tukey's method.

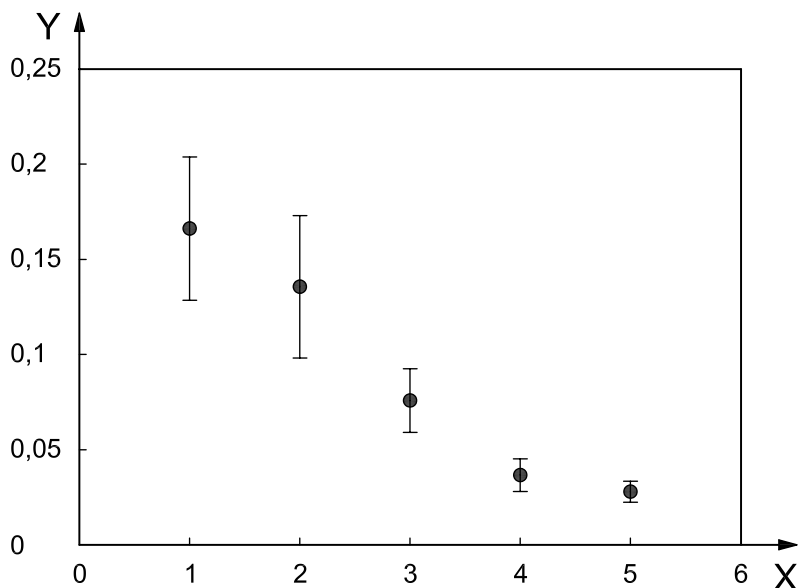

Key

X grade of double seam-pucker replica

Y $d\bar{h}$

Figure A.14 — Relationship between grade and mean of height frequency

A simple regression analysis was performed to verify the linear relationship between grade of replicas and the mean value of height frequency. From the results of this analysis, the R -squared value is 78,70 %, as shown in Table A.12.

Table A.12 — Results of a simple regression analysis on mean of height frequency

Parameter	Regression equation	R^2
$d\bar{h}$	Grade = 4,86 – 21,0 × $d\bar{h}$	78,70 %

A.6.2.5 Maximum value of height frequency (dh_{max})

Figure A.15 shows the relationship between the grade of double seam-pucker replica and the maximum value of height frequency. The ANOVA test and Tukey’s method were performed to confirm the difference in maximum value of height frequency between grades. While the difference between grades was confirmed at the 95 % confidence level with the ANOVA test, grades 4 and 5 are not distinguished at the 95 % confidence level with Tukey’s method.

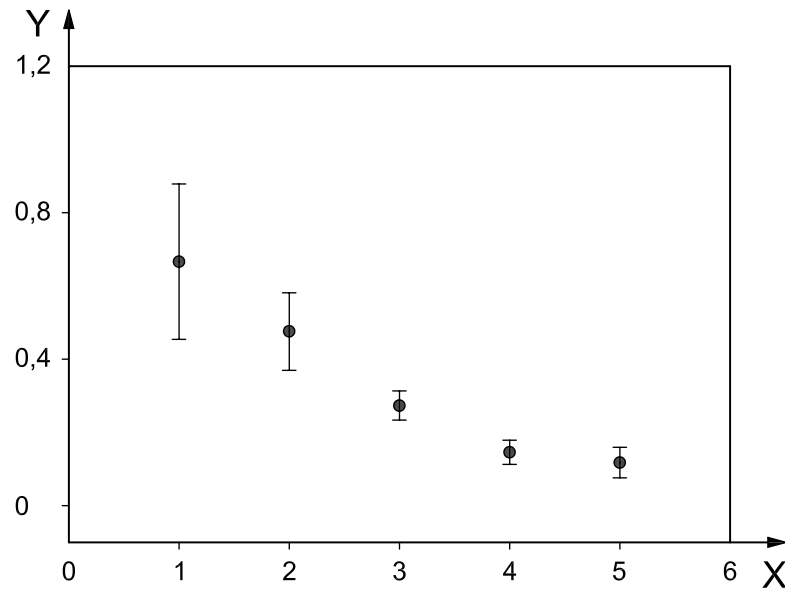

Key

X grade of double seam-pucker replica
 Y dh_{\max}

Figure A.15 — Relationship between grade and maximum of height frequency

A simple regression analysis was performed to verify the linear relationship between the grade of replicas and the maximum value of height frequency. From the results of this analysis, the *R*-squared value is 73,90 %, as shown in Table A.13.

Table A.13 — Results of a simple regression analysis on maximum of height frequency

Parameter	Regression equation	<i>R</i> ²
dh_{\max}	Grade = 4,74 – 5,18 × dh_{\max}	73,90 %

A.6.2.6 Variation of height frequency (dh_{var})

Figure A.16 shows the relationship between the grade of double seam-pucker replica and the variation of height frequency. The ANOVA test and Tukey’s method were performed to confirm the difference in maximum value of height frequency between grades. While the difference between grades was confirmed at the 95 % confidence level with the ANOVA test, grades 4 and 5 are not distinguished at the 95 % confidence level with Tukey’s method.

A simple regression analysis was performed to verify the linear relationship between the grade of replica and the variation of height frequency. From the results of this analysis, the *R*-squared value is 66,90 %, as shown in Table A.14.

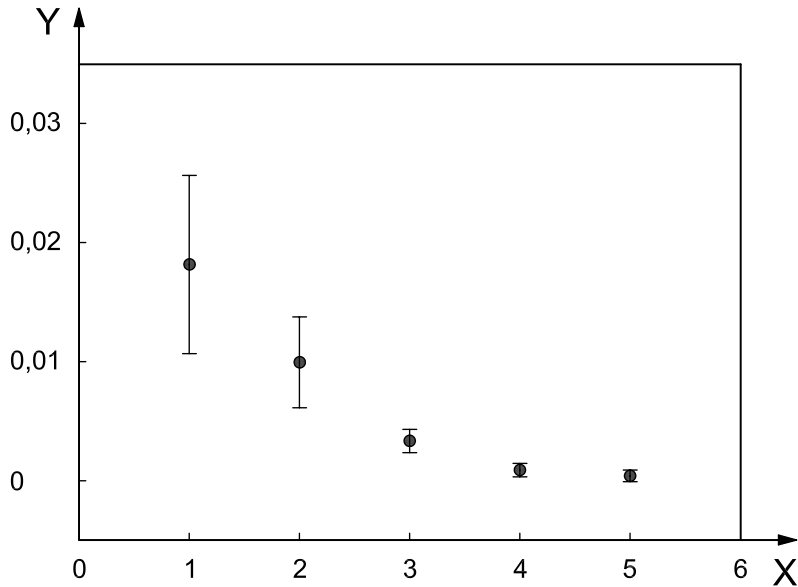

Key

- X grade of double seam-pucker replica
- Y dh_{var}

Figure A.16 — Relationship between grade and variation of height frequency

Table A.14 — Results of a simple regression analysis on variation of height frequency

Parameter	Regression equation	R^2
dh_{var}	Grade = 3,98 – 150 × dh_{var}	66,90 %

A.6.3 Multiple regression analysis

A multiple regression analysis was performed with the six parameters given in A.6.2 to produce an objective seam-puckered sample rating equation. The results are shown in Table A.15. The R -squared value is 88,20 %, which suggests that this regression equation is valid at the 95 % confidence level. Using the regression equation, the subjective and objective grades were compared. A correlation analysis was performed to verify and compare this equation. Table A.16 shows the correlation coefficient between the objective and subjective grades. Figure A.17 shows the relationship between the subjective grade and objective seam-pucker grade obtained from the regression equation.

Table A.15 — Results of the multiple regression analysis

Regression equation, R^2	88,20 %
----------------------------	---------

Table A.16 — Result of the correlation analysis

Correlation coefficient	0,939
-------------------------	-------

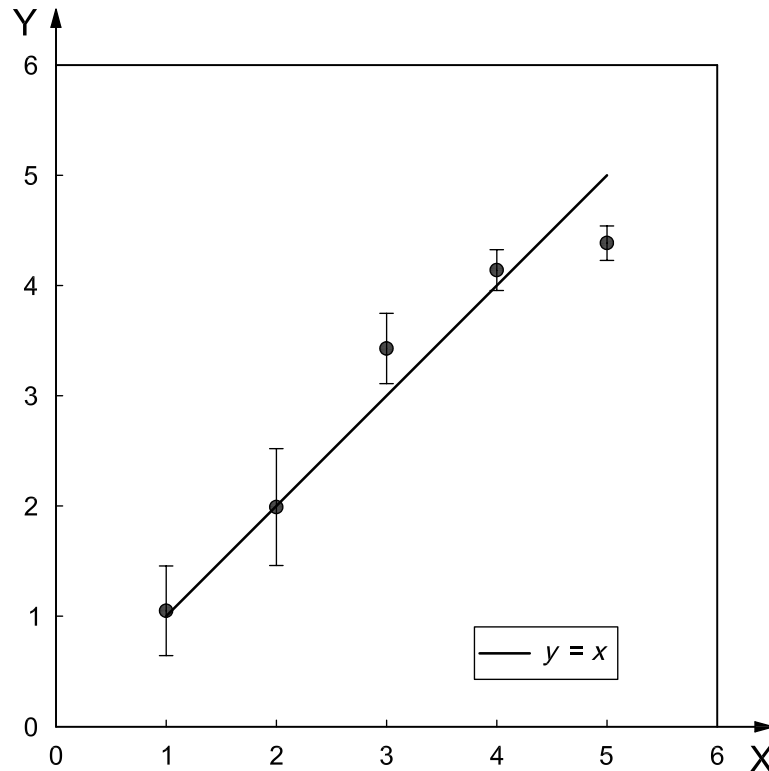

Key

- X subjective grade of double seam-pucker replica
- Y objective grade of double seam-pucker replica using multiple regression equation

Figure A.17 — Relationship between objective and subjective evaluated grades

A.6.4 Conclusion

Six parameters of height and frequency distribution were determined from the images of double seam appearance replicas, and statistical analyses were performed. The ANOVA test results proved that these parameters have strong linearity with the grade of replicas. Multiple regression equations were obtained using these parameters. The results of this analysis indicated a strong linear relationship between the grades of replica and the parameters.

The multiple regression equation with the same parameters was also used to obtain an objective seam-pucker grade. High correlations between the objective and subjective grades were proven. It can be conclusively confirmed that the current ISO seam-pucker replicas are suitable for a subjective rating evaluation.

BSI - British Standards Institution

BSI is the independent national body responsible for preparing British Standards. It presents the UK view on standards in Europe and at the international level. It is incorporated by Royal Charter.

Revisions

British Standards are updated by amendment or revision. Users of British Standards should make sure that they possess the latest amendments or editions.

It is the constant aim of BSI to improve the quality of our products and services. We would be grateful if anyone finding an inaccuracy or ambiguity while using this British Standard would inform the Secretary of the technical committee responsible, the identity of which can be found on the inside front cover. Tel: +44 (0)20 8996 9000. Fax: +44 (0)20 8996 7400.

BSI offers members an individual updating service called PLUS which ensures that subscribers automatically receive the latest editions of standards.

Buying standards

Orders for all BSI, international and foreign standards publications should be addressed to Customer Services. Tel: +44 (0)20 8996 9001. Fax: +44 (0)20 8996 7001 Email: orders@bsigroup.com You may also buy directly using a debit/credit card from the BSI Shop on the Website <http://www.bsigroup.com/shop>

In response to orders for international standards, it is BSI policy to supply the BSI implementation of those that have been published as British Standards, unless otherwise requested.

Information on standards

BSI provides a wide range of information on national, European and international standards through its Library and its Technical Help to Exporters Service. Various BSI electronic information services are also available which give details on all its products and services. Contact Information Centre. Tel: +44 (0)20 8996 7111 Fax: +44 (0)20 8996 7048 Email: info@bsigroup.com

Subscribing members of BSI are kept up to date with standards developments and receive substantial discounts on the purchase price of standards. For details of these and other benefits contact Membership Administration. Tel: +44 (0)20 8996 7002 Fax: +44 (0)20 8996 7001 Email: membership@bsigroup.com

Information regarding online access to British Standards via British Standards Online can be found at <http://www.bsigroup.com/BSOL>

Further information about BSI is available on the BSI website at <http://www.bsigroup.com>

Copyright

Copyright subsists in all BSI publications. BSI also holds the copyright, in the UK, of the publications of the international standardization bodies. Except as permitted under the Copyright, Designs and Patents Act 1988 no extract may be reproduced, stored in a retrieval system or transmitted in any form or by any means – electronic, photocopying, recording or otherwise – without prior written permission from BSI.

This does not preclude the free use, in the course of implementing the standard, of necessary details such as symbols, and size, type or grade designations. If these details are to be used for any other purpose than implementation then the prior written permission of BSI must be obtained.

Details and advice can be obtained from the Copyright and Licensing Manager. Tel: +44 (0)20 8996 7070 Email: copyright@bsigroup.com