

BS ISO 7769:2009



BSI Standards Publication

# Textiles — Test method for assessing the appearance of creases in fabrics after cleansing

NO COPYING WITHOUT BSI PERMISSION EXCEPT AS PERMITTED BY COPYRIGHT LAW

*raising standards worldwide™*



**National foreword**

This British Standard is the UK implementation of ISO 7769:2011. It supersedes BS ISO 7769:2006 which is withdrawn.

The UK participation in its preparation was entrusted to Technical Committee TCI/82, Textiles care labelling, dry cleaning, domestic laundering and drying.

A list of organizations represented on this committee can be obtained on request to its secretary.

This publication does not purport to include all the necessary provisions of a contract. Users are responsible for its correct application.

© BSI 2011

ISBN 978 0 580 62717 0

ICS 59.080.30

**Compliance with a British Standard cannot confer immunity from legal obligations.**

This British Standard was published under the authority of the Standards Policy and Strategy Committee on 31 July 2011.

**Amendments issued since publication**

Date	Text affected
------	---------------

---

INTERNATIONAL  
STANDARD

BS ISO 7769:2009

**ISO**  
**7769**

Fourth edition  
2009-05-15

---

---

**Textiles — Test method for assessing the  
appearance of creases in fabrics after  
cleansing**

*Textiles — Méthode d'essai pour l'évaluation de l'aspect des plis des  
étoffes après nettoyage*



Reference number  
ISO 7769:2009(E)

© ISO 2009

**PDF disclaimer**

This PDF file may contain embedded typefaces. In accordance with Adobe's licensing policy, this file may be printed or viewed but shall not be edited unless the typefaces which are embedded are licensed to and installed on the computer performing the editing. In downloading this file, parties accept therein the responsibility of not infringing Adobe's licensing policy. The ISO Central Secretariat accepts no liability in this area.

Adobe is a trademark of Adobe Systems Incorporated.

Details of the software products used to create this PDF file can be found in the General Info relative to the file; the PDF-creation parameters were optimized for printing. Every care has been taken to ensure that the file is suitable for use by ISO member bodies. In the unlikely event that a problem relating to it is found, please inform the Central Secretariat at the address given below.



**COPYRIGHT PROTECTED DOCUMENT**

© ISO 2009

All rights reserved. Unless otherwise specified, no part of this publication may be reproduced or utilized in any form or by any means, electronic or mechanical, including photocopying and microfilm, without permission in writing from either ISO at the address below or ISO's member body in the country of the requester.

ISO copyright office  
Case postale 56 • CH-1211 Geneva 20  
Tel. + 41 22 749 01 11  
Fax + 41 22 749 09 47  
E-mail [copyright@iso.org](mailto:copyright@iso.org)  
Web [www.iso.org](http://www.iso.org)

Published in Switzerland

## Contents

Page

Foreword.....	iv
<b>1</b> <b>Scope</b> .....	<b>1</b>
<b>2</b> <b>Normative references</b> .....	<b>1</b>
<b>3</b> <b>Principle</b> .....	<b>1</b>
<b>4</b> <b>Apparatus</b> .....	<b>1</b>
<b>5</b> <b>Test specimens</b> .....	<b>4</b>
<b>6</b> <b>Procedure</b> .....	<b>4</b>
<b>7</b> <b>Expression of results</b> .....	<b>5</b>
<b>8</b> <b>Test report</b> .....	<b>5</b>
<b>Annex A</b> (informative) <b>Precision and bias statement</b> .....	<b>7</b>
<b>Annex B</b> (informative) <b>Digital description of the ISO crease replicas</b> .....	<b>9</b>

## Foreword

ISO (the International Organization for Standardization) is a worldwide federation of national standards bodies (ISO member bodies). The work of preparing International Standards is normally carried out through ISO technical committees. Each member body interested in a subject for which a technical committee has been established has the right to be represented on that committee. International organizations, governmental and non-governmental, in liaison with ISO, also take part in the work. ISO collaborates closely with the International Electrotechnical Commission (IEC) on all matters of electrotechnical standardization.

International Standards are drafted in accordance with the rules given in the ISO/IEC Directives, Part 2.

The main task of technical committees is to prepare International Standards. Draft International Standards adopted by the technical committees are circulated to the member bodies for voting. Publication as an International Standard requires approval by at least 75 % of the member bodies casting a vote.

Attention is drawn to the possibility that some of the elements of this document may be the subject of patent rights. ISO shall not be held responsible for identifying any or all such patent rights.

ISO 7769 was prepared by Technical Committee ISO/TC 38, *Textiles*, Subcommittee SC 2, *Cleansing, finishing and water resistance tests*.

This fourth edition cancels and replaces the third edition (ISO 7769:2006), of which it constitutes a minor revision. It incorporates ISO 7769:2006/DAmD.1:2008 to add Annex B (informative).

# Textiles — Test method for assessing the appearance of creases in fabrics after cleansing

## 1 Scope

This International Standard specifies a test method for evaluating the retention of pressed-in creases in fabrics after one or several cleansing treatments. A technique for inserting creases is not included as this is controlled by fabric properties.

This method has been developed for use primarily with type B domestic washing machines, as defined in ISO 6330, in the cleansing process. However, it may be possible to use it with type A machines, as defined in the same International Standard.

## 2 Normative references

The following referenced documents are indispensable for the application of this document. For dated references, only the edition cited applies. For undated references, the latest edition of the referenced document (including any amendments) applies.

ISO 105-A03, *Textiles — Tests for colour fastness — Part A03: Grey scale for assessing staining*

ISO 139, *Textiles — Standard atmospheres for conditioning and testing*

ISO 3175 (all parts), *Textiles — Professional care, drycleaning and wetcleaning of fabrics and garments*

ISO 6330, *Textiles — Domestic washing and drying procedures for textile testing*

## 3 Principle

**3.1** Creased fabric specimens are subjected to procedures simulating cleansing practices. One of the domestic washing and drying procedures specified in ISO 6330 or one of the professional procedures specified in the series of ISO 3175 is used, as agreed between the interested parties.

**3.2** Evaluation is performed by supplementing the overhead lighting arrangement with a spotlight suitably placed to highlight the creased area. The specimens are compared visually with plastic crease replicas under specified illumination.

## 4 Apparatus

**4.1** **Washing and drying apparatus**, as specified in ISO 6330, or **professional care apparatus**, as specified in ISO 3175.

**4.2** **Steam or dry iron**, with appropriate fabric temperature settings.

### 4.3 Lighting.

The evaluation area shall be a darkened room, using the lighting arrangement shown in Figures 1 and 2 and comprising the following items. Lamp dimensions should be chosen to extend beyond the overall surface of a test specimen and replicas, when used for the assessment.

**4.3.1 Two CW (cool white) fluorescent lamps**, without baffle or glass, a minimum of 2 m in length each, placed side by side.

**4.3.2 One white enamel reflector**, without baffle or glass.

**4.3.3 One thick plywood viewing board**, painted grey to the match No. 2 rating on the grey scale for assessing staining specified in ISO 105-A03.

**4.3.4 One 500 W reflector flood lamp and lightshield** (for the purpose of protecting the viewer's eyes from direct light as illustrated in Figure 2).

**4.4 Plastic crease replicas**, prepared for evaluating creases, as shown in Figure 3 <sup>1)</sup>.

NOTE A digital description of the ISO crease replicas is given in Annex B.

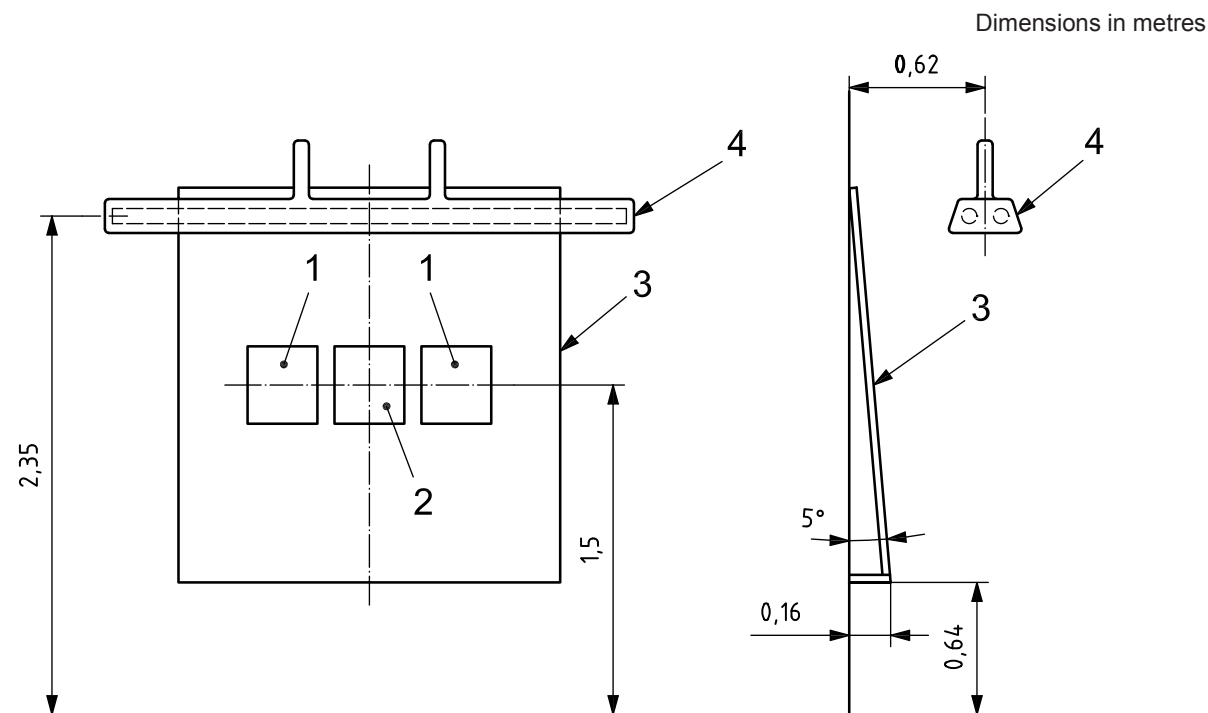

#### Key

- 1 replica
- 2 test specimen
- 3 board for viewing
- 4 example of fluorescent lamp placement

**Figure 1 — Lighting equipment for viewing test specimens**

1) The replicas shown in Figure 3 are for illustration purposes only. These replicas may be obtained from AATCC Technical Center, One Davis Drive, P.O. Box 12215, Research Triangle Park, North Carolina 27709-2215, USA; Tel: +1 919-549-8141; Fax: +1 919-549-8933; <http://www.aatcc.org>. This information is given for the convenience of users of this document and does not constitute an endorsement by ISO of the product named. Equivalent products may be used if they can be shown to lead to the same results.



Dimensions in metres

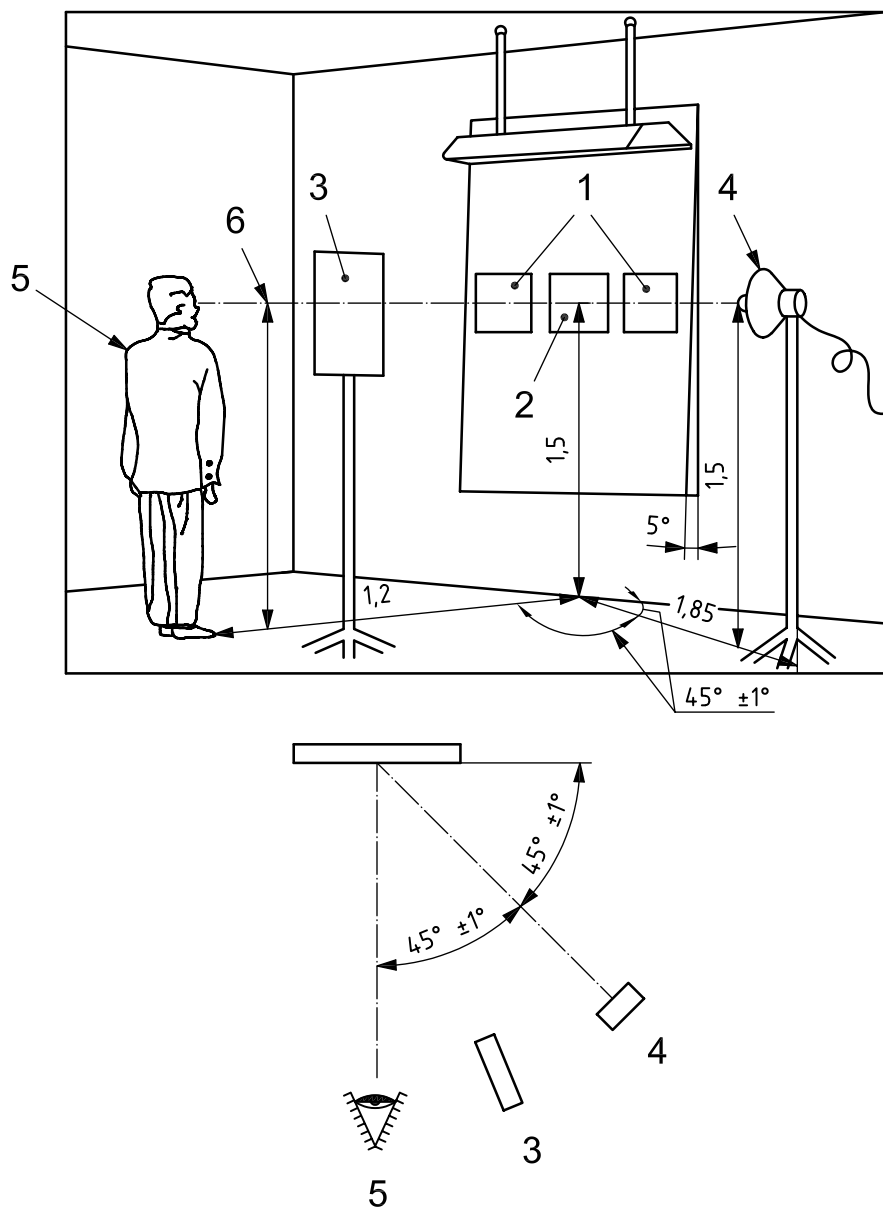

**Key**

- 1 replica
- 2 test specimen
- 3 light shield
- 4 500 W reflector flood lamp
- 5 observer
- 6 arbitrary eye level

**Figure 2 — Lighting and viewing arrangement**

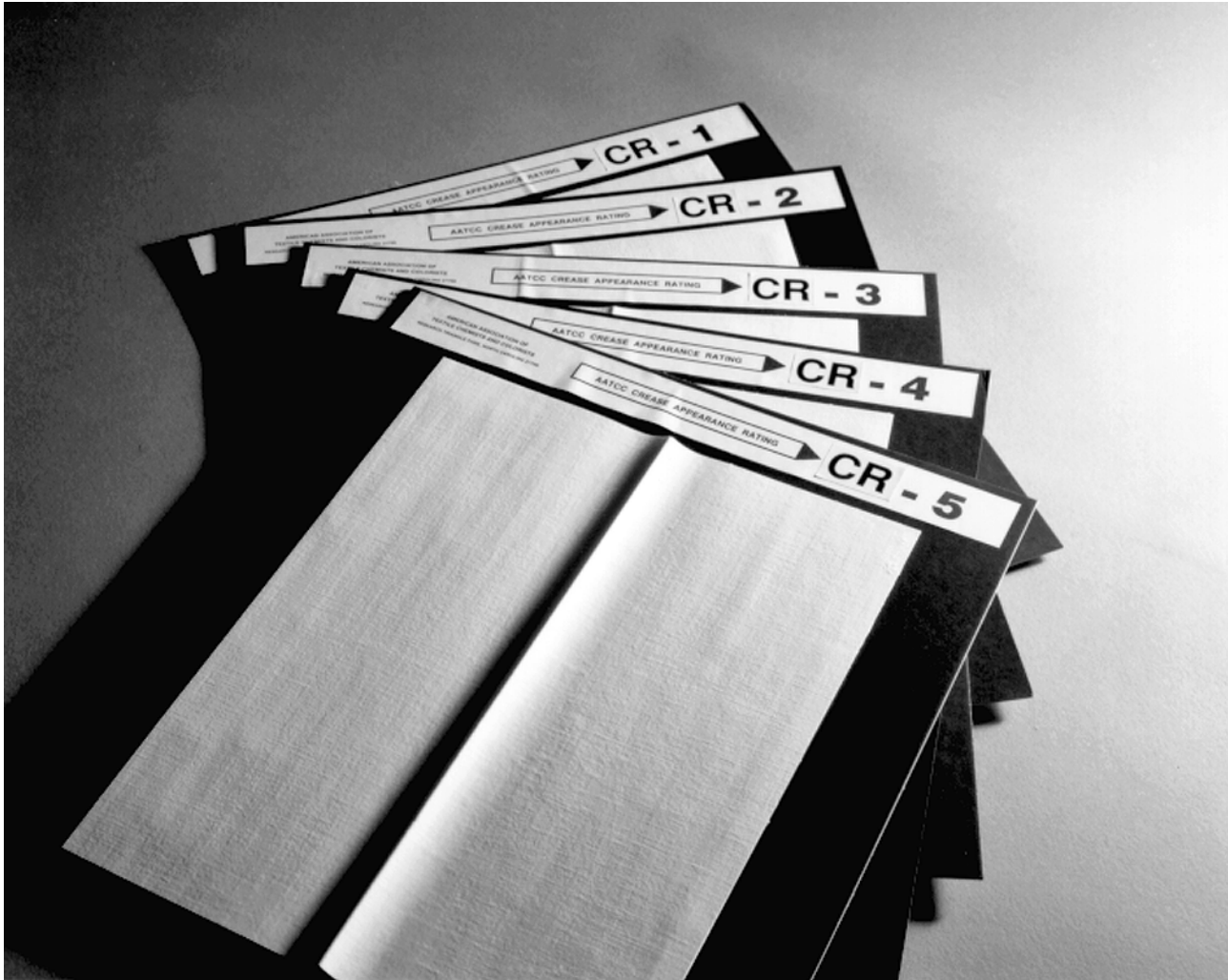

Figure 3 — Plastic crease replicas

## 5 Test specimens

Prepare three test specimens, each measuring 38 cm × 38 cm and pinked to prevent fraying, each with a press-in crease through the middle. If the fabric is wrinkled, it may be smoothed by appropriate ironing prior to testing. Care shall be taken to avoid altering the quality of the crease itself.

## 6 Procedure

- 6.1 Treat each specimen according to one of the procedures specified in ISO 6330 or ISO 3175, as agreed between the interested parties.
- 6.2 If required, repeat the selected treatment four times to give a total of five cycles.
- 6.3 Condition the test specimens for a minimum of 4 h and maximum of 24 h, according to ISO 139, by hanging each specimen by two corners with the crease vertical or, alternatively, using full-width clamps.
- 6.4 For the evaluation, carry out steps 6.4.1 to 6.4.5.
  - 6.4.1 Three observers shall rate each treated test specimen independently, as follows.

**6.4.2** Mount the test specimen on the viewing board (4.3.3) as illustrated in Figure 1, with the crease in the vertical direction, taking care not to distort the crease. Place the plastic crease replicas (4.4) alongside to facilitate comparative rating. Place the most similar plastic crease replicas on each side of the test specimen. Mount replicas 1, 3 or 5 on the left and 2 or 4 on the right.

**6.4.3** The observer shall stand directly in front of the specimen, 1,2 m away from the viewing board. It has been found that normal variations in the height of the observer above and below the arbitrary 1,5 m eye level have no significant effect on the rating given.

The overhead fluorescent light (4.3.1) and the side flood light shall be the only light source for the viewing board, and all other lights in the room shall be turned off. It has been the experience of many observers that the light reflected from the side walls near the viewing board can interfere with the rating results. It is recommended that the side walls be painted black or that blackout curtains be mounted on either side of the viewing board to eliminate the reflective interference.

**6.4.4** Compare the retention of the specimen crease with the plastic crease replicas (see Figure 3), using the prescribed lighting arrangement in a darkened room as shown in Figures 1 and 2. Assign the number of the plastic crease replica that most nearly matches the appearance of the specimen crease (see Figure 3 and Table 1), or assign ratings midway between those whole-number standards, if the appearance of the specimens warrants it.

**Table 1 — Crease appearance ratings**

<b>Class</b>	<b>Crease appearance</b>
5	Equivalent to Standard CR-5
4,5	Midway between Standard CR-4 and CR-5
4	Equivalent to Standard CR-4
3,5	Midway between Standard CR-3 and CR-4
3	Equivalent to Standard CR-3
2,5	Midway between Standard CR-2 and CR-3
2	Equivalent to Standard CR-2
1,5	Midway between Standard CR-1 and CR-2
1	Equivalent to or worse than Standard CR-1

**6.4.5** Similarly, the observer shall independently rate each of the other two test specimens. The other two observers shall proceed in the same manner, assigning ratings independently.

## **7 Expression of results**

Average the nine observations made by the three observers on the set of three test specimens. Report the average to the nearest half of a rating.

## **8 Test report**

The test report shall include the following information:

- a) a reference to this International Standard (ISO 7769:2009);
- b) details of the sample evaluated;

- c) details of the cleansing procedures used;
- d) the number of cleansing cycles used;
- e) the crease appearance rating as calculated in accordance with Clause 7, and expressed according to Table 1;
- f) details of any deviation from the specified procedure.

## Annex A (informative)

### Precision and bias statement

#### A.1 Preliminary tests

A series of inter-laboratory tests was conducted during development of the set of five plastic replica standards. From this work, it was concluded that:

- a) replica standards were preferred over photographic standards;
- b) replica standards did not change the level of ratings;
- c) the absence of side-lighting raised the level of ratings;
- d) rating to half-units improved precision.

This was the basis for adopting the set of replica standards, retaining side-lighting and allowing rating to half-units.

#### A.2 Precision

Using the adopted set of replica standards, five fabrics spanning the range of ratings from 1 to 5, three specimens per fabric, were rated by six observers at a single laboratory location (December 1985). With all conditions identical for the six observers, this data set provided an unbiased estimate of the frequency distribution of observer ratings about an unexpected rating value (or the variability to be expected in observer ratings). Because of the limited and discontinuous scale of replica ratings, the analysis of variance technique was judged not to be applicable to this data set, but such a scale imposes no such restriction with regard to frequency distributions. From the data set, it was determined that observers rate individual specimens to an expected half-rating ( $E$ ) on the following frequency:

Rated a whole unit under the expected value	0,011 11
Rated a half-unit under the expected value	0,133 34
Rated to expected value ( $E$ )	0,600 00
Rated a half-unit over the expected value	0,200 00
Rated a whole unit over the expected value	0,055 55
<b>Total</b>	<hr style="width: 100%; border: 0; border-top: 1px solid black; margin-bottom: 5px;"/> 1,000 00

Starting with the near-normal distribution for observer determinations [designated distribution 1)], it was used to calculate the following additional distributions: 2) the probability of differences between observers (single determination); 3) the distribution of observer totals of three determinations about an expected value; 4) the probability of differences between observers (three determinations per total); 5) the distribution of laboratory totals of three observer totals (nine rating determinations, three each by three observers) about an expected value; and 6) the probability of differences between laboratories (nine determinations per total).

Adhering to fiducial limits based on the usual  $P = 0,05$  (or, in some instances, slightly more favourable), critical differences were established from three different distributions as given in Table A.1.

Table A.1 — Critical differences

Source	Critical difference (average)	Probability <i>P</i>
Between two observers (one determination each)	1	0,03
Between two observers (three determinations each)	0,67	0,02
Between two laboratories (nine determinations each)	0,33 0,50	0,05 0,01

The foregoing was based on observers and laboratories at the same level. When two or more laboratories wish to compare test results, it is recommended that laboratory level be established between them, through ratings of creases on fabrics of known history and performance. Differences greater than the critical differences (on the same fabric, with the same washing and drying conditions) suggest differences in laboratory levels and indicate a need for removing such bias.

### A.3 Bias

The true value of appearance of creases in items after home laundering can be defined only in terms of a test method. There is no independent method for determining the true value.

## Annex B (informative)

### Digital description of the ISO crease replicas

#### B.1 Introduction

This annex provides the digital description of 3-dimensional (3D) replicas. The data are not intended to be used to assess specimens. When assessing specimens, the 3D replicas are to be used.

#### B.2 Processes of measurement and analysis

**B.2.1** A 3-dimensional scanning system was used to measure digital images of ISO crease replicas as shown in Figure B.1. Specifications for the scanning system are shown in Table B.1.

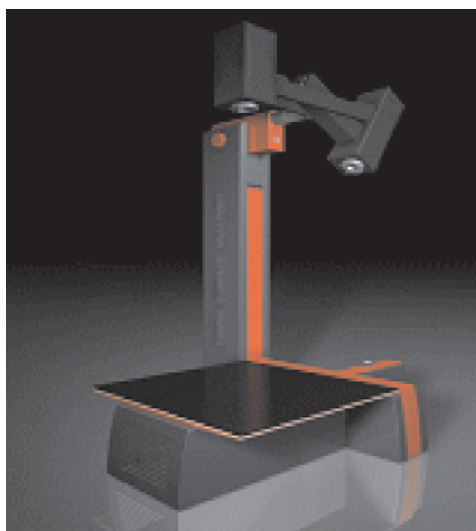
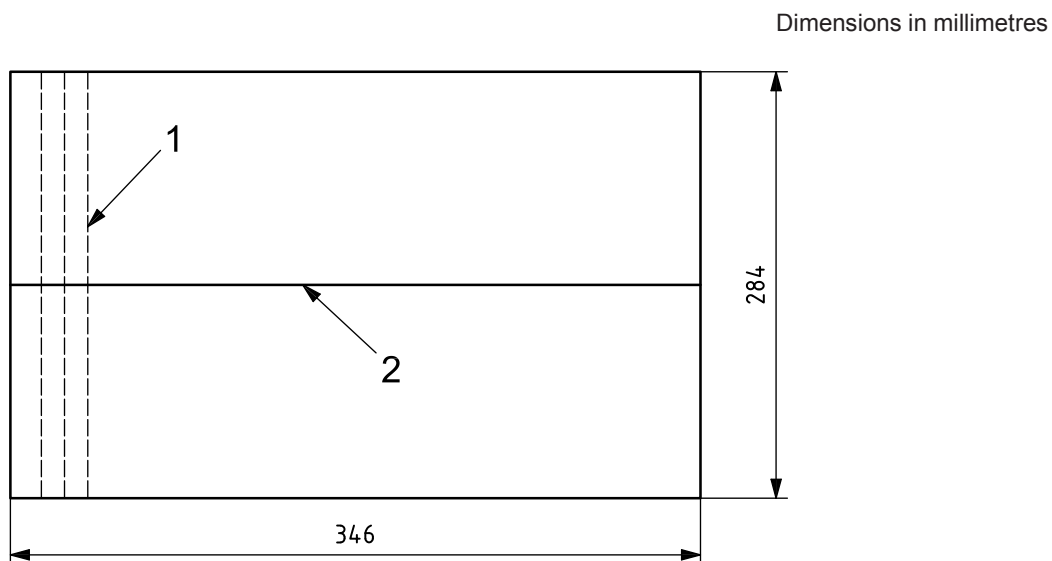

**Figure B.1 — 3-Dimensional scanning system**

**Table B.1 — Specification of the 3-dimensional scanning system**

Camera	1 024 × 768 pixels, black and white (B/W)
Special pattern	Structural beam by halogen lamp
Adjustment of focus	Using the laser-point light source
Measurement time	Approximately 70 s to 80 s
Resolution	± 0,05 mm

**B.2.2** The measuring area is shown in Figure B.2.



**Key**

- 1 measuring lines
- 2 crease line

**Figure B.2 — Measuring area of crease replica**

**B.2.3** A geometric shape of each standard replica is measured using a 3-dimensional laser scanning system in a perpendicular direction with the crease line of the replicas at two intervals of 0,375 mm and 1 mm, respectively. The measuring point intervals along each line are the same as the line intervals, 0,375 mm and 1 mm, respectively. The number of measuring points along each line is determined by the intervals.

To analyse the replicas, the maximum value of height, which is the most important shape parameter having an influence on the grade of replica, was defined. This corresponds to the height of peak points of a crease line. For each line, the parameter can be obtained.

### **B.3 Analysis of crease with 1 mm measurements**

#### **B.3.1 Measured images of crease replicas**

Figure B.3 shows measured images of crease replicas using a 3-dimensional scanning system at intervals of 1 mm.



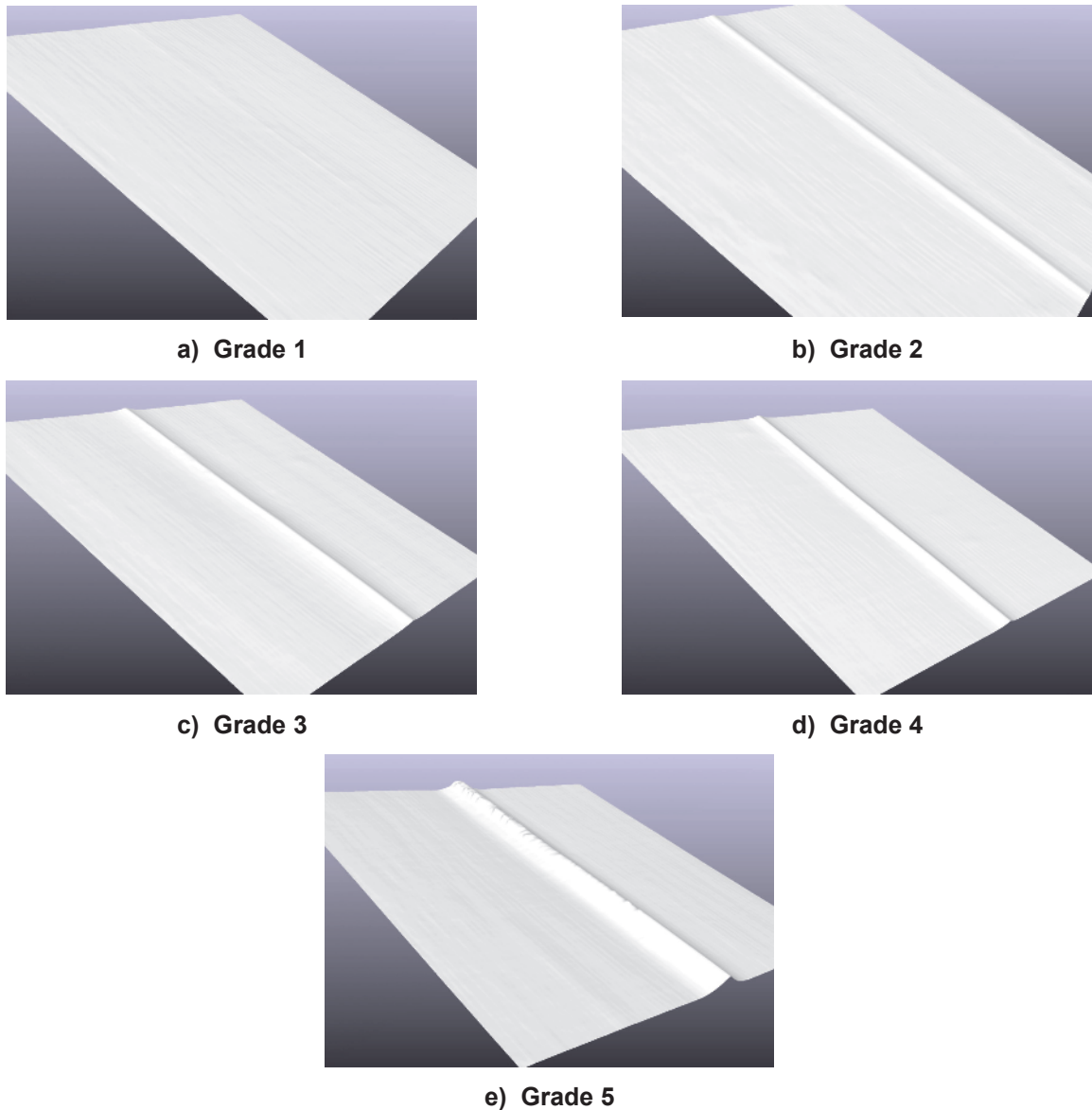

Figure B.3 — Measured images of crease replicas

### B.3.2 Analysis of parameters

#### B.3.2.1 Maximum value of height ( $h_{\max}$ )

Figure B.4 shows the relationship between the crease grade and the maximum value of height. The Analysis Of Variance (ANOVA) test and Tukey's method were performed to confirm differences in this parameter between grades.

With an ANOVA test and Tukey's method, all grades with this data are classified at the 95 % confidence level.

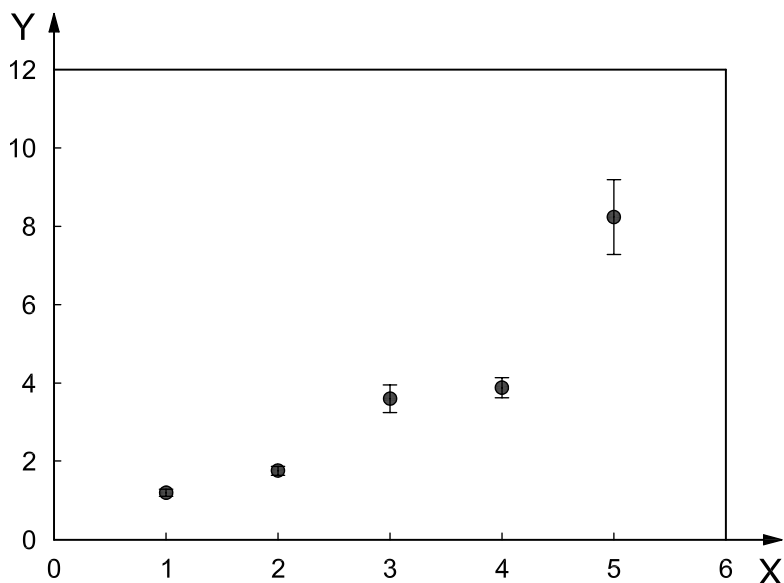

**Key**

X grade  
 Y  $h_{\max}$

**Figure B.4 — Relationship between crease grade and maximum of height for a 1 mm crease**

**B.3.2.2 Regression analysis**

A simple regression analysis is performed to confirm the linear relationship between the grade of replicas and the maximum value of height. From the results of this analysis, the  $R$ -squared value is 82,60 %, as shown in Table B.2.

**Table B.2 — Results of a simple regression analysis**

<b>Regression equation</b>	<b>Grade = 1,10 – 0,51 <math>h_{\max}</math></b>
$R^2$	82,60 %

**B.3.3 Correlation analysis**

The objective grade is obtained from a simple regression equation. Using the regression equation, the objective grade could be compared with the subjective grade from correlation analysis. Table B.3 shows the correlation coefficient between the objective and subjective grades. Figure B.5 shows the relationship between the subjective grade and objective crease grade obtained from the regression equation.

**Table B.3 — Results of correlation analysis**

<b>Correlation coefficient</b>	0,909
--------------------------------	-------

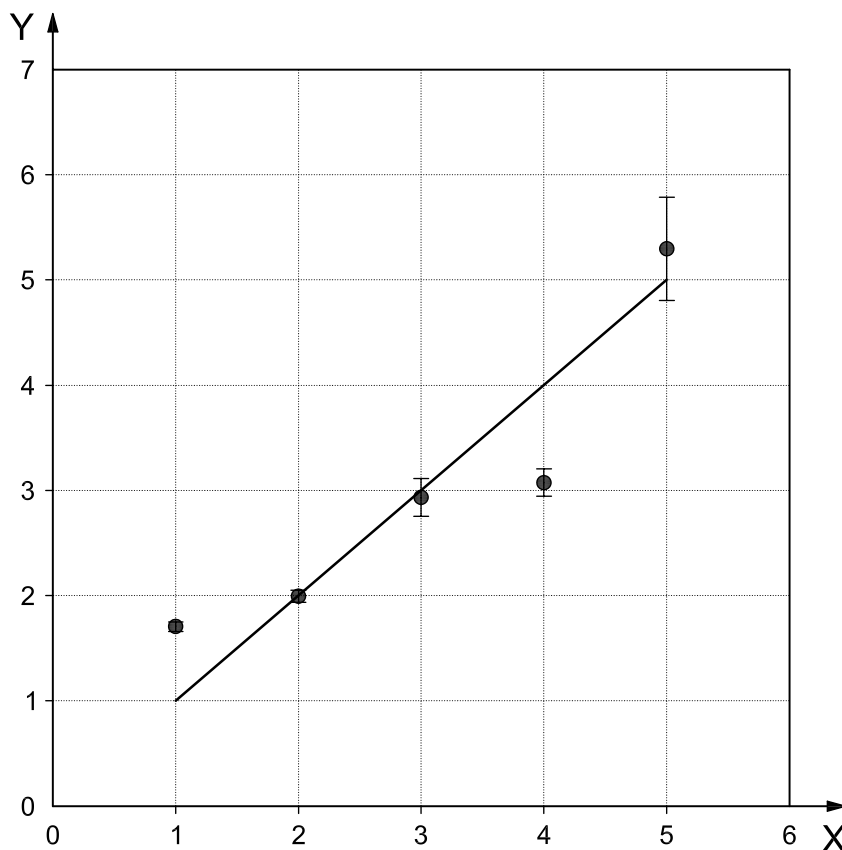

**Key**

- X subjective grade
- Y objective grade using regression equation

**Figure B.5 — Relationship between subjective grade and objective crease grade**

**B.4 Conclusion**

A parameter of maximum height was determined from the images of replicas, and statistical analyses were performed. The ANOVA test results proved that this parameter has a strong linear relationship between the grades of replica and the parameter.

This linear regression equation was also used with the parameter to obtain an objective crease grade. High correlations between the objective and subjective grades of crease samples were proven. This can conclusively confirm that the current ISO crease replicas are suitable for a subjective rating evaluation.





# British Standards Institution (BSI)

BSI is the independent national body responsible for preparing British Standards and other standards-related publications, information and services.

It presents the UK view on standards in Europe and at the international level.

It is incorporated by Royal Charter.

## Revisions

British Standards are updated by amendment or revision. Users of British Standards should make sure that they possess the latest amendments or editions.

It is the constant aim of BSI to improve the quality of our products and services. We would be grateful if anyone finding an inaccuracy or ambiguity while using this British Standard would inform the Secretary of the technical committee responsible, the identity of which can be found on the inside front cover.

**Tel: +44 (0)20 8996 9001 Fax: +44 (0)20 8996 7001**

BSI offers Members an individual updating service called PLUS which ensures that subscribers automatically receive the latest editions of standards.

**Tel: +44 (0)20 8996 7669 Fax: +44 (0)20 8996 7001**

**Email: [plus@bsigroup.com](mailto:plus@bsigroup.com)**

## Buying standards

You may buy PDF and hard copy versions of standards directly using a credit card from the BSI Shop on the website [www.bsigroup.com/shop](http://www.bsigroup.com/shop). In addition all orders for BSI, international and foreign standards publications can be addressed to BSI Customer Services.

**Tel: +44 (0)20 8996 9001 Fax: +44 (0)20 8996 7001**

**Email: [orders@bsigroup.com](mailto:orders@bsigroup.com)**

In response to orders for international standards, it is BSI policy to supply the BSI implementation of those that have been published as British Standards, unless otherwise requested.

## Information on standards

BSI provides a wide range of information on national, European and international standards through its Knowledge Centre.

**Tel: +44 (0)20 8996 7004 Fax: +44 (0)20 8996 7005**

**Email: [knowledgecentre@bsigroup.com](mailto:knowledgecentre@bsigroup.com)**

Various BSI electronic information services are also available which give details on all its products and services.

**Tel: +44 (0)20 8996 7111 Fax: +44 (0)20 8996 7048**

**Email: [info@bsigroup.com](mailto:info@bsigroup.com)**

BSI Subscribing Members are kept up to date with standards developments and receive substantial discounts on the purchase price of standards. For details of these and other benefits contact Membership Administration.

**Tel: +44 (0)20 8996 7002 Fax: +44 (0)20 8996 7001**

**Email: [membership@bsigroup.com](mailto:membership@bsigroup.com)**

Information regarding online access to British Standards via British Standards Online can be found at [www.bsigroup.com/BSOL](http://www.bsigroup.com/BSOL)

Further information about BSI is available on the BSI website at [www.bsigroup.com/standards](http://www.bsigroup.com/standards)

## Copyright

Copyright subsists in all BSI publications. BSI also holds the copyright, in the UK, of the publications of the international standardization bodies. Except as permitted under the Copyright, Designs and Patents Act 1988 no extract may be reproduced, stored in a retrieval system or transmitted in any form or by any means – electronic, photocopying, recording or otherwise – without prior written permission from BSI. This does not preclude the free use, in the course of implementing the standard of necessary details such as symbols, and size, type or grade designations. If these details are to be used for any other purpose than implementation then the prior written permission of BSI must be obtained. Details and advice can be obtained from the Copyright & Licensing Manager.

**Tel: +44 (0)20 8996 7070**

**Email: [copyright@bsigroup.com](mailto:copyright@bsigroup.com)**

## BSI Group Headquarters

389 Chiswick High Road London W4 4AL UK

Tel +44 (0)20 8996 9001

Fax +44 (0)20 8996 7001

[www.bsigroup.com/standards](http://www.bsigroup.com/standards)