

BS ISO 7267-3:2011



BSI Standards Publication

# Rubber-covered rollers — Determination of apparent hardness

Part 3: Pusey and Jones method

**bsi.**

...making excellence a habit.™

**National foreword**

This British Standard is the UK implementation of ISO 7267-3:2011. It supersedes BS ISO 7267-3:2007 which is withdrawn.

The UK participation in its preparation was entrusted to Technical Committee PRI/22, Physical testing of rubber.

A list of organizations represented on this committee can be obtained on request to its secretary.

This publication does not purport to include all the necessary provisions of a contract. Users are responsible for its correct application.

© BSI 2011

ISBN 978 0 580 73711 4

ICS 83.140.99

**Compliance with a British Standard cannot confer immunity from legal obligations.**

This British Standard was published under the authority of the Standards Policy and Strategy Committee on 30 November 2011.

**Amendments issued since publication**

Date	Text affected
------	---------------

---

# INTERNATIONAL STANDARD

BS ISO 7267-3:2011

**ISO**  
**7267-3**

Third edition  
2011-11-01

---

---

## Rubber-covered rollers — Determination of apparent hardness —

### Part 3: Pusey and Jones method

*Cylindres revêtus de caoutchouc — Détermination de la dureté  
apparente — Partie 3: Méthode Pusey et Jones*



Reference number  
ISO 7267-3:2011(E)

© ISO 2011



**COPYRIGHT PROTECTED DOCUMENT**

© ISO 2011

All rights reserved. Unless otherwise specified, no part of this publication may be reproduced or utilized in any form or by any means, electronic or mechanical, including photocopying and microfilm, without permission in writing from either ISO at the address below or ISO's member body in the country of the requester.

ISO copyright office  
Case postale 56 • CH-1211 Geneva 20  
Tel. + 41 22 749 01 11  
Fax + 41 22 749 09 47  
E-mail [copyright@iso.org](mailto:copyright@iso.org)  
Web [www.iso.org](http://www.iso.org)

Published in Switzerland

<b>Contents</b>		Page
<b>Foreword</b> .....		<b>iv</b>
<b>Introduction</b> .....		<b>v</b>
<b>1</b>	<b>Scope</b> .....	<b>1</b>
<b>2</b>	<b>Normative references</b> .....	<b>1</b>
<b>3</b>	<b>Terms and definitions</b> .....	<b>1</b>
<b>4</b>	<b>Time-interval between vulcanization/finished grinding and testing</b> .....	<b>2</b>
<b>5</b>	<b>Conditioning and temperature of test</b> .....	<b>2</b>
<b>6</b>	<b>Apparatus</b> .....	<b>2</b>
<b>7</b>	<b>Calibration</b> .....	<b>2</b>
<b>8</b>	<b>Procedure</b> .....	<b>3</b>
<b>9</b>	<b>Expression of results</b> .....	<b>3</b>
<b>10</b>	<b>Test report</b> .....	<b>3</b>
<b>Annex A (normative) Calibration schedule</b> .....		<b>6</b>
<b>Bibliography</b> .....		<b>8</b>

## Foreword

ISO (the International Organization for Standardization) is a worldwide federation of national standards bodies (ISO member bodies). The work of preparing International Standards is normally carried out through ISO technical committees. Each member body interested in a subject for which a technical committee has been established has the right to be represented on that committee. International organizations, governmental and non-governmental, in liaison with ISO, also take part in the work. ISO collaborates closely with the International Electrotechnical Commission (IEC) on all matters of electrotechnical standardization.

International Standards are drafted in accordance with the rules given in the ISO/IEC Directives, Part 2.

The main task of technical committees is to prepare International Standards. Draft International Standards adopted by the technical committees are circulated to the member bodies for voting. Publication as an International Standard requires approval by at least 75 % of the member bodies casting a vote.

Attention is drawn to the possibility that some of the elements of this document may be the subject of patent rights. ISO shall not be held responsible for identifying any or all such patent rights.

ISO 7267-3 was prepared by Technical Committee ISO/TC 45, *Rubber and rubber products*, Subcommittee SC 2, *Testing and analysis*.

This third edition cancels and replaces the second edition (ISO 7267-3:2007), of which it constitutes a minor revision to include an annex specifying a calibration schedule for the apparatus used.

ISO 7267 consists of the following parts, under the general title *Rubber-covered rollers — Determination of apparent hardness*:

- *Part 1: IRHD method*
- *Part 2: Shore-type durometer method*
- *Part 3: Pusey and Jones method*

## Introduction

The hardness of a roller covering has traditionally been determined on the finished roller, since it is this hardness that is critical to the correct functioning of the roller in its end application. Values of hardness, determined by whichever method is chosen, are therefore dependent not only on the method employed and on the rubber, but also on the diameter of the roller, on the thickness of the covering and, in the case of thin coverings, on the nature of the roller core. For this reason the term “apparent hardness” is used to distinguish between the values obtained by the methods described in the various parts of this International Standard and those that would be obtained for the rubber if it was possible to use the standard test methods for standard test pieces forming the subjects of other International Standards.

Since rollers vary considerably in size, construction and end use, and in view of the fact that hardness determinations are made for such different purposes as specification and factory process control, it has not been possible to standardize one test method. Consequently, three methods are described, each capable of standing alone (see Foreword).





# Rubber-covered rollers — Determination of apparent hardness —

## Part 3: Pusey and Jones method

**WARNING** — Persons using this part of ISO 7267 should be familiar with normal laboratory practice. This part of ISO 7267 does not purport to address all of the safety problems, if any, associated with its use. It is the responsibility of the user to establish appropriate safety and health practices and to ensure compliance with any national regulatory conditions.

**IMPORTANT** — Certain procedures specified in this part of ISO 7267 might involve the use or generation of substances, or the generation of waste, that could constitute a local environmental hazard. Reference should be made to appropriate documentation on safe handling and disposal after use.

### 1 Scope

This part of ISO 7267 specifies a method for the determination of the apparent hardness of vulcanized- or thermoplastic-rubber roller covers, expressed as the Pusey and Jones indentation value.

The Pusey and Jones plastometer apparatus is used to measure the depth of indentation of an indenter under a specified force into the surface of the rubber. The indentation value should not be confused with hardness as measured by the international rubber hardness test method ISO 48<sup>[1]</sup>, since in this method the rubber immediately adjacent to the indenter is precompressed. The Pusey and Jones indentation value is an inverse measurement of hardness, i.e. the harder the rubber the lower the Pusey and Jones indentation value.

### 2 Normative references

The following referenced documents are indispensable for the application of this document. For dated references, only the edition cited applies. For undated references, the latest edition of the referenced document (including any amendments) applies.

ISO 18899:2004, *Rubber — Guide to the calibration of test equipment*

ISO 23529, *Rubber — General procedures for preparing and conditioning test pieces for physical test methods*

### 3 Terms and definitions

For the purpose of this document, the following terms and definitions apply.

#### 3.1

##### **Pusey and Jones indentation value**

depth of indentation, in hundredths of a millimetre, of a ball 3,175 mm in diameter under a force of 9,8 N

## 4 Time-interval between vulcanization/finished grinding and testing

Tests shall be carried out not less than 16 h after vulcanization and/or finished grinding and, for arbitration purposes, not less than 72 h after vulcanization (see ISO 23529).

## 5 Conditioning and temperature of test

Where possible, the test shall be carried out at standard laboratory temperature in accordance with ISO 23529. The product under test should be maintained under the test condition for sufficient time to reach temperature equilibrium with the test environment. Where this is impracticable, the period of time and the conditions shall be given in the product specification (see the Note).

The same temperature shall be used throughout any one test or series of tests intended to be comparable.

NOTE For large rollers having heavy metal cores, ambient conditions might not allow equilibrium temperatures to be obtained.

## 6 Apparatus

**6.1 Plastometer**, consisting of a supporting frame, an indenter, a mass for applying a fixed gravitational force on the indenter, a depth indicator and a specimen holder.

**6.1.1 Supporting frame**, so configured that the indenter and mass can be independently raised or lowered vertically, permitting the indenter to rest on the surface of the test roller and the mass to be applied subsequently to the indenter.

**6.1.2 Indenter**, consisting of a vertical steel shaft attached at the upper end to the spindle of the indicator gauge and having at the lower end a steel ball. The steel ball shall be  $(3,175 \pm 0,015)$  mm in diameter and shall be made of highly polished, non-corrosive hard metal properly treated to resist wear.

**6.1.3 Mass**, of  $(1\ 000 \pm 2)$  g.

**6.1.4 Depth indicator**, comprising a dial gauge or other suitable device graduated in increments of 0,01 mm and having a range of at least 3 mm to indicate the movement of the indenter.

**6.1.5 Specimen holder**, consisting of a clamp made of two metal plates held together by two threaded bolts as shown in Figure 1. The purpose of the clamp is to hold the test roller flat and free from slight movements that might introduce variations into the test. The top plate shall be provided with a hole and slot for the operation of the indenter.

## 7 Calibration

The test apparatus shall be calibrated in accordance with Annex A.

## 8 Procedure

**8.1** Firmly position the roller to be tested with its major axis horizontal and with the area in which the hardness is to be measured uppermost. Place the plastometer (6.1), with the axis of the indenter (6.1.2) vertical, on the roller over the position where the hardness is to be measured and lower the indenter into contact with the roller surface and until the gauge needle of the depth indicator (6.1.4) makes three revolutions. Adjust the dial gauge to read zero. Apply the indenting force by lowering the supporting frame (6.1.1) so that the mass (6.1.3) rests fully on the indenter as shown by a space of approximately 5 mm between the supporting plate and the shoulder of the mass tube. Read the amount of indentation on the gauge 60 s after the application of the force.

**8.2** Make three measurements, at different points at least 6 mm apart, within each test area in which the hardness is to be determined.

NOTE Several test areas along the length and around the circumference of the roller might be required to determine the average hardness of the covering and the hardness variation over a single roller (see ISO 6123-1<sup>[2]</sup>).

## 9 Expression of results

Express the apparent hardness as the median of three measurements for each test area, reported to the nearest whole number as the Pusey and Jones indentation value.

## 10 Test report

The test report shall include the following information:

- a) a full description of the roller and its origin;
- b) a full reference to the test method used, i.e. the reference number of this part of ISO 7267;
- c) test details:
  - 1) the time and temperature of conditioning prior to test,
  - 2) the temperature of test, if other than a standard laboratory temperature, and the relative humidity if necessary,
  - 3) details of any procedures not specified in this part of ISO 7267;
- d) test results:
  - 1) the number of areas or rollers tested,
  - 2) the individual test results,
  - 3) the apparent hardness, expressed as the Pusey and Jones indentation value (see Clause 9);
- e) the date of the test.

Dimensions in millimetres

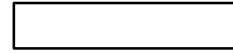
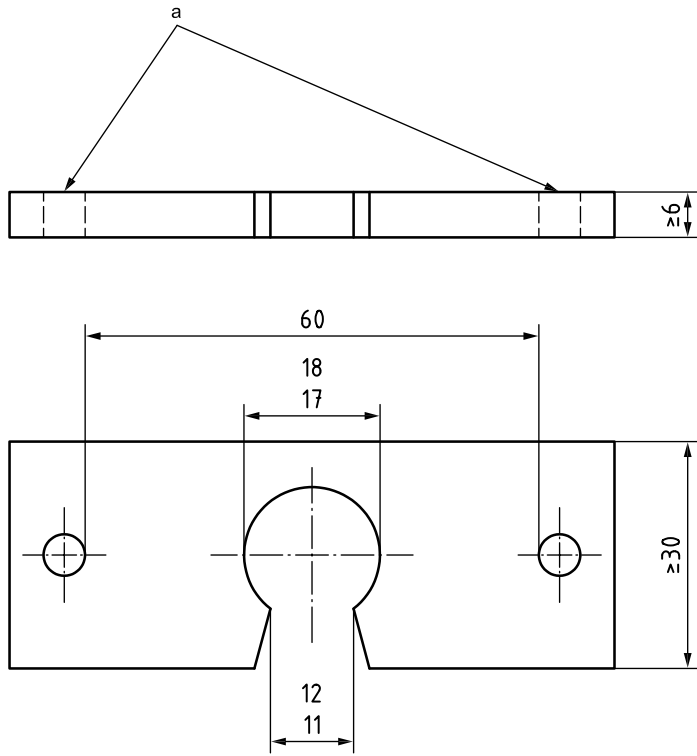

a) Top plate

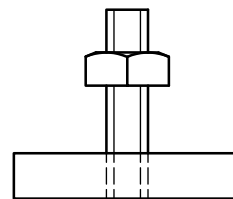
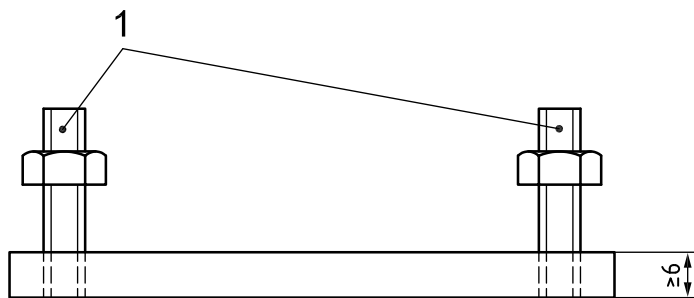
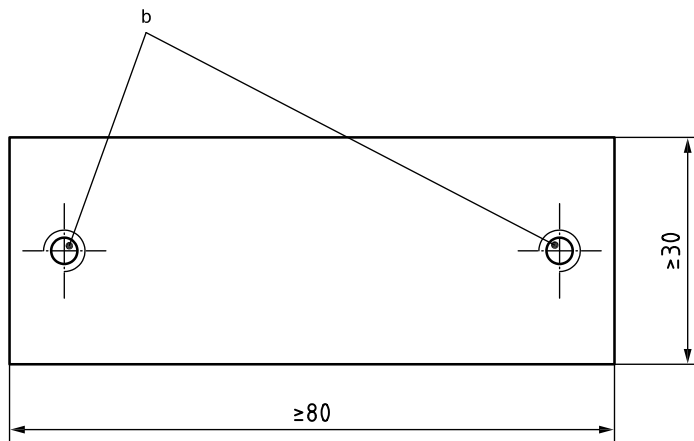

b) Bottom plate

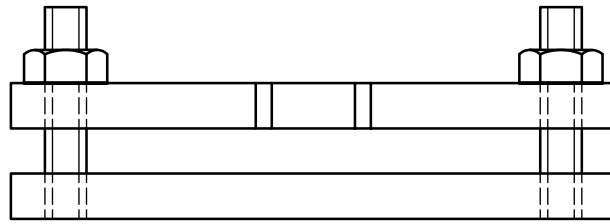

c) Assembled view

**Key**

- 1 threaded bolts
- a Drill to clear stud bolts.
- b Tap for stud bolts.

**Figure 1 — Holder for test specimen**

## Annex A (normative)

### Calibration schedule

#### A.1 Inspection

Before any calibration is undertaken, the condition of the items to be calibrated shall be ascertained by inspection and recorded on any calibration report or certificate. It shall be reported whether calibration is carried out in the “as-received” condition or after rectification of any abnormality or fault.

It shall be ascertained that the apparatus is generally fit for the intended purpose, including any parameters specified as approximate and for which the apparatus does not therefore need to be formally calibrated. If such parameters are liable to change, then the need for periodic checks shall be written into the detailed calibration procedures.

#### A.2 Schedule

Verification/calibration of the test apparatus is a mandatory part of this part of ISO 7267. However, the frequency of calibration and the procedures used are, unless otherwise stated, at the discretion of the individual laboratory, using ISO 18899 for guidance.

The calibration schedule given in Table A.1 has been compiled by listing all of the parameters specified in the test method, together with the specified requirement. A parameter and requirement can relate to the main test apparatus, to part of that apparatus or to an ancillary apparatus necessary for the test.

For each parameter, a calibration procedure is indicated by reference to ISO 18899, to another publication or to a procedure particular to the test method which is detailed (whenever a calibration procedure which is more specific or detailed than that in ISO 18899 is available, it shall be used in preference).

The verification frequency for each parameter is given by a code-letter. The code-letters used in the calibration schedule are:

- C requirement to be confirmed, but no measurement;
- N initial verification only;
- S standard interval as given in ISO 18899.

**Table A.1 — Calibration frequency schedule**

Parameter	Requirement	Subclause in ISO 18899:2004	Verification frequency guide	Notes
Plastometer	As specified in 6.1	C	N	
Supporting frame	As specified in 6.1.1	C	N	
Indentor	Polished steel ball, diameter 3,175 mm ± 0,015 mm	15.2	S	
Mass	1 000 g ± 2 g	22.2	S	
Depth indicator	Range of 3 mm graduated in 0,01 mm	15.1	S	
Specimen holder	As specified in 6.1.5	C	N	

In addition to the items listed in Table A.1, use of the following is implied, all of which need calibrating in accordance with ISO 18899:

- a timer;
- a thermometer for monitoring the conditioning and test temperatures.

## Bibliography

- [1] ISO 48, *Rubber, vulcanized or thermoplastic — Determination of hardness (hardness between 10 IRHD and 100 IRHD)*
- [2] ISO 6123-1, *Rubber or plastics covered rollers — Specifications — Part 1: Requirements for hardness*









# British Standards Institution (BSI)

BSI is the national body responsible for preparing British Standards and other standards-related publications, information and services.

BSI is incorporated by Royal Charter. British Standards and other standardization products are published by BSI Standards Limited.

## About us

We bring together business, industry, government, consumers, innovators and others to shape their combined experience and expertise into standards-based solutions.

The knowledge embodied in our standards has been carefully assembled in a dependable format and refined through our open consultation process. Organizations of all sizes and across all sectors choose standards to help them achieve their goals.

## Information on standards

We can provide you with the knowledge that your organization needs to succeed. Find out more about British Standards by visiting our website at [bsigroup.com/standards](http://bsigroup.com/standards) or contacting our Customer Services team or Knowledge Centre.

## Buying standards

You can buy and download PDF versions of BSI publications, including British and adopted European and international standards, through our website at [bsigroup.com/shop](http://bsigroup.com/shop), where hard copies can also be purchased.

If you need international and foreign standards from other Standards Development Organizations, hard copies can be ordered from our Customer Services team.

## Subscriptions

Our range of subscription services are designed to make using standards easier for you. For further information on our subscription products go to [bsigroup.com/subscriptions](http://bsigroup.com/subscriptions).

With **British Standards Online (BSOL)** you'll have instant access to over 55,000 British and adopted European and international standards from your desktop. It's available 24/7 and is refreshed daily so you'll always be up to date.

You can keep in touch with standards developments and receive substantial discounts on the purchase price of standards, both in single copy and subscription format, by becoming a **BSI Subscribing Member**.

**PLUS** is an updating service exclusive to BSI Subscribing Members. You will automatically receive the latest hard copy of your standards when they're revised or replaced.

To find out more about becoming a BSI Subscribing Member and the benefits of membership, please visit [bsigroup.com/shop](http://bsigroup.com/shop).

With a **Multi-User Network Licence (MUNL)** you are able to host standards publications on your intranet. Licences can cover as few or as many users as you wish. With updates supplied as soon as they're available, you can be sure your documentation is current. For further information, email [bsmusales@bsigroup.com](mailto:bsmusales@bsigroup.com).

## BSI Group Headquarters

389 Chiswick High Road London W4 4AL UK

## Revisions

Our British Standards and other publications are updated by amendment or revision.

We continually improve the quality of our products and services to benefit your business. If you find an inaccuracy or ambiguity within a British Standard or other BSI publication please inform the Knowledge Centre.

## Copyright

All the data, software and documentation set out in all British Standards and other BSI publications are the property of and copyrighted by BSI, or some person or entity that owns copyright in the information used (such as the international standardization bodies) and has formally licensed such information to BSI for commercial publication and use. Except as permitted under the Copyright, Designs and Patents Act 1988 no extract may be reproduced, stored in a retrieval system or transmitted in any form or by any means – electronic, photocopying, recording or otherwise – without prior written permission from BSI. Details and advice can be obtained from the Copyright & Licensing Department.

## Useful Contacts:

### Customer Services

**Tel:** +44 845 086 9001

**Email (orders):** [orders@bsigroup.com](mailto:orders@bsigroup.com)

**Email (enquiries):** [cservices@bsigroup.com](mailto:cservices@bsigroup.com)

### Subscriptions

**Tel:** +44 845 086 9001

**Email:** [subscriptions@bsigroup.com](mailto:subscriptions@bsigroup.com)

### Knowledge Centre

**Tel:** +44 20 8996 7004

**Email:** [knowledgecentre@bsigroup.com](mailto:knowledgecentre@bsigroup.com)

### Copyright & Licensing

**Tel:** +44 20 8996 7070

**Email:** [copyright@bsigroup.com](mailto:copyright@bsigroup.com)



...making excellence a habit.™