



BSI Standards Publication

## Fire detection and alarm systems

Part 8: Point-type fire detectors using a carbon monoxide sensor in combination with a heat sensor

**National foreword**

This British Standard is the UK implementation of ISO 7240-8:2014. It supersedes BS ISO 7240-8:2007 which is withdrawn.

The UK participation in its preparation was entrusted to Technical Committee FSH/12/2, Fire detectors.

A list of organizations represented on this committee can be obtained on request to its secretary.

This publication does not purport to include all the necessary provisions of a contract. Users are responsible for its correct application.

© The British Standards Institution 2015. Published by BSI Standards Limited 2015

ISBN 978 0 580 82457 9

ICS 13.220.20

**Compliance with a British Standard cannot confer immunity from legal obligations.**

This British Standard was published under the authority of the Standards Policy and Strategy Committee on 31 January 2015.

**Amendments issued since publication**

Date	Text affected
------	---------------

---

---

---

**Fire detection and alarm systems —**  
**Part 8:**  
**Point-type fire detectors using**  
**a carbon monoxide sensor in**  
**combination with a heat sensor**

*Systèmes de détection et d'alarme d'incendie —*

*Partie 8: Détecteurs ponctuels utilisant un capteur de monoxyde de carbone en combinaison avec un capteur de chaleur*





**COPYRIGHT PROTECTED DOCUMENT**

© ISO 2014

All rights reserved. Unless otherwise specified, no part of this publication may be reproduced or utilized otherwise in any form or by any means, electronic or mechanical, including photocopying, or posting on the internet or an intranet, without prior written permission. Permission can be requested from either ISO at the address below or ISO's member body in the country of the requester.

ISO copyright office  
Case postale 56 • CH-1211 Geneva 20  
Tel. + 41 22 749 01 11  
Fax + 41 22 749 09 47  
E-mail [copyright@iso.org](mailto:copyright@iso.org)  
Web [www.iso.org](http://www.iso.org)

Published in Switzerland

# Contents

	Page
<b>Foreword</b> .....	<b>vi</b>
<b>Introduction</b> .....	<b>viii</b>
<b>1 Scope</b> .....	<b>1</b>
<b>2 Normative references</b> .....	<b>1</b>
<b>3 Terms and definitions and abbreviated terms</b> .....	<b>2</b>
3.1 Terms and definitions.....	2
3.2 Abbreviated terms.....	2
<b>4 Requirements</b> .....	<b>2</b>
4.1 Compliance.....	2
4.2 Individual alarm indication.....	2
4.3 Connection of ancillary devices.....	3
4.4 Monitoring of detachable detectors.....	3
4.5 Manufacturer's adjustments.....	3
4.6 On-site adjustment of response behaviour.....	3
4.7 Rate-sensitive response behaviour.....	3
4.8 Requirements for software-controlled detectors.....	4
4.8.1 General.....	4
4.8.2 Software design.....	4
4.8.3 The storage of programs and data.....	4
<b>5 Tests</b> .....	<b>4</b>
5.1 General.....	4
5.1.1 Atmospheric conditions for tests.....	4
5.1.2 Mounting arrangements.....	4
5.1.3 Operating conditions for tests.....	5
5.1.4 Tolerances.....	5
5.1.5 Measurement of CO response value.....	5
5.1.6 Measurement of heat sensor response value.....	6
5.1.7 Provision for tests.....	6
5.1.8 Test schedule.....	7
5.1.9 Test report.....	7
5.2 Repeatability of CO response.....	7
5.2.1 Object of the test.....	7
5.2.2 Test procedure.....	7
5.2.3 Requirements.....	7
5.3 Directional dependence of CO response.....	8
5.3.1 Object of the test.....	8
5.3.2 Test procedure.....	8
5.3.3 Requirements.....	9
5.4 Directional dependence of heat response.....	9
5.4.1 Object of the test.....	9
5.4.2 Test procedure.....	9
5.4.3 Requirements.....	9
5.5 Lower limit of heat sensitivity.....	9
5.5.1 Object of the test.....	9
5.5.2 Test procedure.....	9
5.5.3 Requirements.....	10
5.6 Reproducibility of CO response.....	10
5.6.1 Object of the test.....	10
5.6.2 Test procedure.....	10
5.6.3 Requirements.....	10

5.7	Reproducibility of heat response .....	10
5.7.1	Object of the test .....	10
5.7.2	Test procedure .....	10
5.7.3	Requirements .....	11
5.8	Exposure to chemical agents at environmental concentrations .....	11
5.8.1	Object of the test .....	11
5.8.2	Test procedure .....	11
5.8.3	Requirements .....	11
5.9	Long-term stability of CO response .....	12
5.9.1	Object of the test .....	12
5.9.2	Test procedure .....	12
5.9.3	Requirements .....	12
5.10	Saturation .....	12
5.10.1	Object of the test .....	12
5.10.2	Test procedure .....	13
5.10.3	Requirements .....	13
5.11	Exposure to chemical agents which may be present during a fire .....	13
5.11.1	Object of the test .....	13
5.11.2	Test procedure .....	13
5.11.3	Requirements .....	14
5.12	Variation in supply parameters .....	14
5.12.1	Object of the test .....	14
5.12.2	Test procedure .....	14
5.12.3	Requirements .....	15
5.13	Air movement .....	15
5.13.1	Object of the test .....	15
5.13.2	Test procedure .....	15
5.13.3	Requirements .....	15
5.14	Dry heat (operational) .....	16
5.14.1	Object of the test .....	16
5.14.2	Test procedure .....	16
5.14.3	Requirements .....	16
5.15	Dry heat endurance .....	16
5.15.1	Object .....	16
5.15.2	Test procedure .....	17
5.15.3	Requirements .....	17
5.16	Cold (operational) .....	17
5.16.1	Object of the test .....	17
5.16.2	Test procedure .....	18
5.16.3	Requirements .....	18
5.17	Damp heat, cyclic (operational) .....	19
5.17.1	Object .....	19
5.17.2	Test procedure .....	19
5.17.3	Requirements .....	19
5.18	Damp heat, steady-state (endurance) .....	20
5.18.1	Object of the test .....	20
5.18.2	Test procedure .....	20
5.18.3	Requirements .....	20
5.19	Low humidity, steady-state (endurance) .....	21
5.19.1	Object of the test .....	21
5.19.2	Test procedure .....	21
5.19.3	Requirements .....	21
5.20	Sulfur dioxide SO <sub>2</sub> corrosion (endurance) .....	22
5.20.1	Object of the test .....	22
5.20.2	Test procedure .....	22
5.20.3	Requirements .....	22

5.21	Shock (operational)	23
5.21.1	Object of the test	23
5.21.2	Test procedure	23
5.21.3	Requirements	24
5.22	Impact (operational)	24
5.22.1	Object of the test	24
5.22.2	Test procedure	24
5.22.3	Requirements	25
5.23	Vibration, sinusoidal, (operational)	25
5.23.1	Object of the test	25
5.23.2	Test procedure	25
5.23.3	Requirements	26
5.24	Vibration, sinusoidal (endurance)	26
5.24.1	Object of the test	26
5.24.2	Test procedure	26
5.24.3	Requirements	27
5.25	Electromagnetic Compatibility (EMC), Immunity tests (operational)	27
5.26	Fire sensitivity	28
5.26.1	Object of the test	28
5.26.2	Test procedure	28
<b>6</b>	<b>Test report</b>	<b>30</b>
<b>7</b>	<b>Marking</b>	<b>30</b>
<b>8</b>	<b>Data</b>	<b>31</b>
8.1	Hardware documentation	31
8.2	Software documentation	31
<b>Annex A</b>	<b>(normative) Gas test chamber for CO response value and cross sensitivity measurements</b>	<b>33</b>
<b>Annex B</b>	<b>(normative) Heat tunnel for response time and response temperature measurements</b>	<b>34</b>
<b>Annex C</b>	<b>(normative) Apparatus for impact test</b>	<b>35</b>
<b>Annex D</b>	<b>(normative) Fire test room</b>	<b>37</b>
<b>Annex E</b>	<b>(normative) Smouldering (pyrolysis) wood fire (TF2)</b>	<b>39</b>
<b>Annex F</b>	<b>(normative) Glowing smouldering cotton fire (TF3)</b>	<b>43</b>
<b>Annex G</b>	<b>(normative) Open plastics (polyurethane) fire (TF4)</b>	<b>47</b>
<b>Annex H</b>	<b>(normative) Liquid (<i>n</i>-heptane) fire (TF5)</b>	<b>50</b>
<b>Annex I</b>	<b>(informative) Information concerning the construction of the gas test chamber</b>	<b>53</b>
<b>Annex J</b>	<b>(informative) Construction of the heat tunnel</b>	<b>55</b>

## Foreword

ISO (the International Organization for Standardization) is a worldwide federation of national standards bodies (ISO member bodies). The work of preparing International Standards is normally carried out through ISO technical committees. Each member body interested in a subject for which a technical committee has been established has the right to be represented on that committee. International organizations, governmental and non-governmental, in liaison with ISO, also take part in the work. ISO collaborates closely with the International Electrotechnical Commission (IEC) on all matters of electrotechnical standardization.

The procedures used to develop this document and those intended for its further maintenance are described in the ISO/IEC Directives, Part 1. In particular the different approval criteria needed for the different types of ISO documents should be noted. This document was drafted in accordance with the editorial rules of the ISO/IEC Directives, Part 2 (see [www.iso.org/directives](http://www.iso.org/directives)).

Attention is drawn to the possibility that some of the elements of this document may be the subject of patent rights. ISO shall not be held responsible for identifying any or all such patent rights. Details of any patent rights identified during the development of the document will be in the Introduction and/or on the ISO list of patent declarations received (see [www.iso.org/patents](http://www.iso.org/patents)).

Any trade name used in this document is information given for the convenience of users and does not constitute an endorsement.

For an explanation on the meaning of ISO specific terms and expressions related to conformity assessment, as well as information about ISO's adherence to the WTO principles in the Technical Barriers to Trade (TBT) see the following URL: [Foreword — Supplementary information](#).

The committee responsible for this document is ISO/TC 21, *Equipment for fire protection and firefighting*, Subcommittee SC 3, *Fire detection and alarm systems*.

This second edition cancels and replaces the first edition (ISO 7240-8:2007), which has been technically revised.

ISO 7240 consists of the following parts, under the general title *Fire detection and alarm systems*:

- *Part 1: General and definitions*
- *Part 2: Control and indicating equipment*
- *Part 3: Audible alarm devices*
- *Part 4: Power supply equipment*
- *Part 5: Point-type heat detectors*
- *Part 6: Carbon monoxide fire detectors using electro-chemical cells*
- *Part 7: Point-type smoke detectors using scattered light, transmitted light or ionization*
- *Part 8: Point-type fire detectors using a carbon monoxide sensor in combination with a heat sensor*
- *Part 9: Test fires for fire detectors [Technical Specification]*
- *Part 10: Point-type flame detectors*
- *Part 11: Manual call points*
- *Part 12: Line type smoke detectors using a transmitted optical beam*
- *Part 13: Compatibility assessment of system components*



- *Part 14: Design, installation, commissioning and service of fire detection and fire alarm systems in and around buildings*
- *Part 15: Point-type fire detectors using smoke and heat sensors*
- *Part 16: Sound system control and indicating equipment*
- *Part 17: Short-circuit isolators*
- *Part 18: Input/output devices*
- *Part 19: Design, installation, commissioning and service of sound systems for emergency purposes*
- *Part 20: Aspirating smoke detectors*
- *Part 21: Routing equipment*
- *Part 22: Smoke-detection equipment for ducts*
- *Part 23: Visual alarm devices*
- *Part 24: Sound-system loudspeakers*
- *Part 25: Components using radio transmission paths*
- *Part 27: Point-type fire detectors using scattered light, transmitted-light or ionization smoke sensor, an electrochemical-cell carbon-monoxide sensor and a heat sensor*
- *Part 28: Fire protection control equipment*

The following parts are under preparation:

- *Part 29: Video fire detectors*

## Introduction

This part of ISO 7240 has been prepared by the Subcommittee ISO/TC 21/SC 3 and is based on ISO 7240-8:2007.

A fire detection and fire alarm system is required to function satisfactorily not only in the event of a fire, but also during and after exposure to conditions likely to be met in practice such as corrosion, vibration, direct impact, indirect shock, and electromagnetic interference. Some tests specified are intended to assess the performance of the fire detectors under such conditions.

Test Fires TF2, TF3, TF4, and TF5 from ISO/TS 7240-9 have been included to verify the detection performance of point fire detectors using a combination of carbon monoxide and heat sensors (CO) sensors. TF4 and TF5 specifically demonstrate the influence of the heat sensor(s). For these Test Fires, the CO level and, where applicable, the temperature is used as test validity criteria. This part of ISO 7240 is not intended to place any other restrictions on the design and construction of such detectors.

Carbon monoxide (CO) fire detectors can react promptly to slow smouldering fires involving carbonaceous materials. Although in the majority of fires, the products of combustion will be transported by convection, the gaseous nature of CO means that it will also diffuse and, particularly in low energy fires, it can move ahead of the smoke plume and, thus, provide earlier detection.

CO fire detectors alone might not react quickly to flaming fires and the addition of a heat sensor as specified in this part of ISO 7240 provides better detection to a broader spectrum of fires.

CO fire detectors based on a combination of a CO sensor and a heat sensor might also be better suited to applications where smoke detectors can produce unwanted alarms due to the presence of dust, steam, or cooking vapours, etc.

While CO gas has greater mobility than smoke, it can be diluted by ventilation systems and be affected by convection currents. Hence, the same considerations as for point smoke detectors should be taken into account. Re-circulating systems confined to a single room have little effect on dilution, as this is similar to the natural diffusion of the CO gas.

It is important that the location of CO fire detectors take into account areas where false operation or non-operation is likely. Some typical locations where it is important to carefully evaluate the use of CO fire detectors are as follows:

- a) areas where CO gas can be present from exhausts and normal manufacturing processes;  
EXAMPLE Car parks, car-park return air plenums, loading docks.
- b) confined areas where tobacco smoking is likely.

# Fire detection and alarm systems —

## Part 8:

# Point-type fire detectors using a carbon monoxide sensor in combination with a heat sensor

## 1 Scope

This part of ISO 7240 specifies requirements, test methods, and performance criteria for point multi-sensor fire detectors that incorporate at least one carbon monoxide (CO) sensor in combination with one or more heat sensors, for use in fire detection and alarm systems installed in buildings (see ISO 7240-1).

For the testing of other types of CO multi-sensor fire detectors, or CO and heat multi-sensor fire detectors working on different principles, this part of ISO 7240 is only to be used for guidance. CO and heat multi-sensor fire detectors with special characteristics and developed for specific risks are not covered by this part of ISO 7240.

## 2 Normative references

The following documents, in whole or in part, are normatively referenced in this document and are indispensable for its application. For dated references, only the edition cited applies. For undated references, the latest edition of the referenced document (including any amendments) applies.

ISO 209, *Aluminium and aluminium alloys — Chemical composition*

ISO 7240-1, *Fire detection and alarm systems — Part 1: General and definitions*

ISO 7240-5:2012, *Fire detection and alarm systems — Part 5: Point-type heat detectors*

IEC 60068-1, *Environmental testing Part 1: General and guidance*

IEC 60068-2-1, *Environmental testing Part 2: Tests — Test A: Cold*

IEC 60068-2-2, *Environmental testing Part 2-2: Tests — Test B: Dry heat*

IEC 60068-2-6, *Environmental testing — Part 2: Tests — Test Fc: Vibration [sinusoidal]*

IEC 60068-2-27, *Basic environmental testing procedures Part 2: Tests — Test Ea and guidance: Shock*

IEC 60068-2-30, *Environmental testing — Part 2-30: Tests — Test Db Damp heat, cyclic (12 h+ 12 h cycle)*

IEC 60068-2-42, *Environmental testing — Part 2-42: Tests — Test Kc: Sulphur dioxide test for contacts and connections*

IEC 60068-2-78, *Environmental testing — Part 2-78: Tests — Test Cab: Damp heat, steady state*

IEC 62599-2, *Alarm systems — Part 2: Electromagnetic compatibility — Immunity requirements for components of fire and security alarm systems*

## 3 Terms and definitions and abbreviated terms

### 3.1 Terms and definitions

For the purposes of this document, the terms, definitions, and abbreviated terms given in ISO 7240-1 and the following apply.

#### 3.1.1

##### **CO response value**

CO concentration in the proximity of the specimen at the moment that it generates an alarm signal, when tested as described in [5.1.5](#)

Note 1 to entry: The CO response value may depend on signal processing in the detector and in the fire detection control and indicating equipment.

#### 3.1.2

##### **rate-sensitive**

behaviour of a detector that depends on the rate of change of CO concentration

### 3.2 Abbreviated terms

CO carbon-monoxide

EMC electromagnetic compatibility

FDCIE fire detection control and indicating equipment

## 4 Requirements

### 4.1 Compliance

In order to comply with this part of ISO 7240, the detector shall meet the following requirements.

- a) [Clause 4](#), which shall be verified by visual inspection or engineering assessment, shall be tested as described in [Clause 5](#) and shall meet the requirements of the tests.
- b) [Clauses 7](#) and [8](#), which shall be verified by visual inspection.

### 4.2 Individual alarm indication

**4.2.1** Each detector shall be provided with an integral red visual indicator, by which the individual detector that released an alarm can be identified, until the alarm condition is reset. Where other conditions of the detector might be visually indicated, these shall be clearly distinguishable from the alarm indication, except when the detector is switched into a service mode. For detachable detectors, the indicator can be integral with the base or the detector head.

**4.2.2** The visual indicator shall be visible from a distance of 6 m in an ambient light intensity up to 500 lx at an angle of up to

- a) 5° from the axis of the detector in any direction, and
- b) 45° from the axis of the detector in at least one direction.

### 4.3 Connection of ancillary devices

The detector may provide for connections to ancillary devices (e.g. remote indicators, control relays, etc.), but open- or short-circuit failures of these connections shall not prevent the correct operation of the detector.

### 4.4 Monitoring of detachable detectors

For detachable detectors, a means shall be provided for a remote monitoring system (e.g. the FDCIE) to detect the removal of the head from the base, in order to give a fault signal.

### 4.5 Manufacturer's adjustments

It shall not be possible to change the manufacturer's settings except by special means (e.g. the use of a special code or tool) or by breaking or removing a seal.

### 4.6 On-site adjustment of response behaviour

**4.6.1** If there is provision for on-site adjustment of the response behaviour of the detector, then the following should be observed:

- a) for all of the settings, at which the manufacturer claims compliance with this part of ISO 7240, the detector shall comply with the requirements of this part of ISO 7240 and access to the adjustment means shall be possible only by the use of a code or special tool or by removing the detector from its base or mounting;
- b) any setting(s) at which the manufacturer does not claim compliance with this part of ISO 7240 shall be accessible only by the use of a code or special tool, and it shall be clearly marked on the detector or in the associated data that if these setting(s) are used the detector does not comply with this part of ISO 7240.

**4.6.2** Adjustments may be carried out at the detector or at the FDCIE.

### 4.7 Rate-sensitive response behaviour

**4.7.1** The CO response value of the detector might depend on the rate of change of CO concentration in the vicinity of the detector. Such behaviour may be incorporated in the detector design to improve the discrimination between ambient CO concentrations and those generated by a fire. If such rate-sensitive behaviour is included, then it shall not lead to a significant reduction in the sensitivity of the detector to fires, nor shall it lead to a significant increase in the probability of unwanted alarms.

**4.7.2** Since it is not practical to make tests with all possible rates of increase in CO concentration, an assessment of the rate sensitivity of the detector shall be made by analysis of the circuit/software and/or physical tests and simulations.

**4.7.3** The detector shall be deemed to meet the requirements of this Clause, if this assessment shows the following:

- a) for any rate of increase in CO concentration less than 1 µl/l per minute, the detector will signal an alarm condition before the CO concentration reaches 60 µl/l; and
- b) the detector does not produce an alarm condition when subjected to a step change in CO concentration of 10 µl/l, superimposed on a background concentration of between 0 µl/l and 5 µl/l.

## 4.8 Requirements for software-controlled detectors

### 4.8.1 General

The requirements of [4.8.2](#) and [4.8.3](#) shall apply to detectors that rely on software control in order to fulfil the requirements of this part of ISO 7240.

### 4.8.2 Software design

In order to ensure the reliability of the detector, the following requirements for software design shall apply.

- a) The software shall have a modular structure.
- b) The design of the interfaces for manually and automatically generated data shall not permit invalid data to cause error in the program operation.
- c) The software shall be designed to avoid the occurrence of deadlock of the program flow.

### 4.8.3 The storage of programs and data

**4.8.3.1** The program necessary to comply with this part of ISO 7240 and any preset data, such as manufacturer's settings, shall be held in non-volatile memory. Writing to areas of memory containing this program and data shall be possible only by the use of some special tool or code and shall not be possible during normal operation of the detector.

**4.8.3.2** Site-specific data shall be held in memory that will retain data for at least two weeks without external power to the detector, unless provision is made for the automatic renewal of such data, following loss of power, within 1 h of power being restored.

## 5 Tests

### 5.1 General

#### 5.1.1 Atmospheric conditions for tests

**5.1.1.1** Unless otherwise stated in a test procedure, the testing shall be carried out after the test specimen has been allowed to stabilize in the standard atmospheric conditions for testing as specified in IEC 60068-1 as follows:

temperature: (15 to 35) °C;

relative humidity: (25 to 75) %;

air pressure: (86 to 106) kPa.

**5.1.1.2** The temperature and humidity shall be substantially constant for each environmental test where the standard atmospheric conditions are applied.

#### 5.1.2 Mounting arrangements

The specimen shall be mounted by its normal means of attachment in accordance with the manufacturer's instructions. If these instructions describe more than one method of mounting, then the method considered to be most unfavourable shall be chosen for each test.

### 5.1.3 Operating conditions for tests

**5.1.3.1** If a test method requires a specimen to be operational, then the specimen shall be connected to suitable supply and monitoring equipment with characteristics as required by the manufacturer's data. Unless otherwise specified in the test method, the supply parameters applied to the specimen shall be set within the manufacturer's specified range(s) and shall remain substantially constant throughout the tests. The value chosen for each parameter shall normally be the nominal value, or the mean of the specified range. If a test procedure requires a specimen to be monitored to detect any alarm or fault signals, then connections shall be made to any necessary ancillary devices (e.g. through wiring to an end-of-line device for non-addressable detectors) to allow a fault signal to be recognized.

**5.1.3.2** The details of the supply and monitoring equipment and the alarm criteria used shall be given in the test report (see [Clause 6](#)).

### 5.1.4 Tolerances

**5.1.4.1** Unless otherwise stated, the tolerances for the environmental test parameters shall be as given in the basic reference standards for the test (e.g. the relevant part of IEC 60068).

**5.1.4.2** If a specific tolerance or deviation limit is not specified in a requirement or test procedure, then a deviation limit of  $\pm 5\%$  shall be applied.

### 5.1.5 Measurement of CO response value

**5.1.5.1** Install the specimen for which the CO response value is to be measured in a gas test chamber, as specified in [Annex A](#), in its normal operating position, by its normal means of attachment. The orientation of the specimen, relative to the direction of gas flow, shall be the least sensitive orientation as determined in the directional dependence test (see [5.3](#)), unless otherwise specified in the test procedure.

**5.1.5.2** Purge the gas test chamber to ensure that the carbon monoxide concentration is less than  $1\ \mu\text{l/l}$  prior to each test.

**5.1.5.3** The air velocity in the proximity of the specimen shall be  $(0,2 \pm 0,04)\ \text{m/s}$  during the measurement, unless otherwise specified in the test procedure.

**5.1.5.4** Unless otherwise specified in the test procedure, the air temperature in the gas test chamber shall be  $(23 \pm 5)\ ^\circ\text{C}$  and shall not vary by more than 5 K for all the measurements on a particular detector type.

**5.1.5.5** Connect the specimen to its supply and monitoring equipment as specified in [5.1.3](#), and allow it to stabilize for a period of at least 15 min, unless otherwise specified by the manufacturer.

**5.1.5.6** For detectors whose response is rate sensitive, the manufacturer may specify a rate of increase within this range to ensure that the measured response value is representative of the static response value of the detector. The rate of increase in CO concentration shall be similar for all measurements on a particular detector type.

**5.1.5.7** Introduce carbon monoxide gas at a rate of between  $1\ \mu\text{l/l/min}$  and  $6\ \mu\text{l/l/min}$  until the specimen has entered an alarm state. For detectors whose response is rate sensitive, the manufacturer may specify a rate of increase within this range to ensure that the measured response value is representative of the static response value of the detector.

NOTE To avoid unnecessary high levels of CO, the test can be stopped when the CO concentration reaches  $100\ \mu\text{l/l}$ .

**5.1.5.8** The rate of increase in CO concentration shall be similar for all measurements on a particular detector type.

**5.1.5.9** Record the carbon monoxide concentration at the moment the specimen gives an alarm. This shall be taken as the CO response value, *S*.

### **5.1.6 Measurement of heat sensor response value**

**5.1.6.1** Where detectors comply with ISO 7240-5, the response times measured in those tests may be used as the heat response values for the purposes of this part of ISO 7240.

**5.1.6.2** Install the specimen for which the temperature response value is to be measured in a heat tunnel, as specified in [Annex B](#), in its normal operating position, by its normal means of attachment. The orientation of the specimen, relative to the direction of airflow, shall be the least sensitive one, as determined in the directional dependence test (see [5.4](#)), unless otherwise specified in the test procedure.

**5.1.6.3** Connect the specimen to its supply and indicating equipment as specified in [5.1.3](#), and allow it to stabilize for at least 15 min.

**5.1.6.4** Before the test, stabilize the temperature of the air stream and the specimen to  $(25 \pm 2)$  °C. Maintain the air stream at a constant mass flow equivalent to a velocity of  $(0,8 \pm 0,1)$  m/s at 25 °C.

**5.1.6.5** Raise the air temperature at a rate specified in the test and measure the heat response value as specified in ISO 7240-5:2012, 5.1.5 until the signal specified by the manufacturer is produced by the heat sensor.

**NOTE** If the detector is not capable of giving an alarm signal from heat alone, it will be necessary for the manufacturer to provide special means by which the heat response value can be measured. For example, it may be acceptable to provide a supplementary output that varies with temperature, or specially modified software to indicate when the air temperature has caused an internal temperature threshold to be reached. In such cases, the special means should preferably be chosen such that the nominal heat response value corresponds to a response time between the minimum and maximum times given in ISO 7240-5:2012, Table 4 for a class A2 detector. It is essential that the output signal be routed through the amplification path.

**5.1.6.6** Assess the heat response value as follows:

- a) the time taken from the start of the temperature increase to the point at which the heat signal reaches a level specified by the manufacturer, or the detector gives an alarm signal, or
- b) the change in signal level produced in a certain time.

**NOTE** A shorter time will represent a higher sensitivity while a larger change will represent a higher sensitivity.

**5.1.6.7** Record the measured heat response value as *T*.

### **5.1.7 Provision for tests**

**5.1.7.1** The following shall be provided for testing compliance with this part of ISO 7240:

- for detachable detectors: 25 detector heads and bases;

**NOTE** Detachable detectors comprise at least two parts: a base (socket) and a head (body). If the specimens are detachable detectors, then the two, or more, parts together are regarded as a complete detector.

- for non-detachable detectors: 25 specimens;
- the data required in [Clause 8](#);



— means to enable a quantitative measurement of the heat response value of the temperature sensing element(s) of the detector according to [5.1.6](#).

**5.1.7.2** The specimens submitted shall be deemed representative of the manufacturer's normal production with regard to their construction and calibration. This implies that the mean response value of the specimens found in the reproducibility test (see [5.6](#) and [5.7](#)), should also represent the production mean, and that the limits specified in the reproducibility test should also be applicable to the manufacturer's production.

### 5.1.8 Test schedule

The specimens shall be tested according to the following test schedule (see [Table 1](#)). After the reproducibility test, number the four least sensitive specimens (i.e. those with the highest CO response value) as 22 to 25, and number the remaining as 1 to 21 arbitrarily.

### 5.1.9 Test report

The test results shall be reported in accordance with [Clause 6](#).

## 5.2 Repeatability of CO response

### 5.2.1 Object of the test

To show that the detector has stable behaviour with respect to its CO sensitivity even after a number of alarm conditions.

### 5.2.2 Test procedure

**5.2.2.1** Measure the CO response value of the specimen to be tested six times as specified in [5.1.5](#). The orientation of the specimen, relative to the direction of airflow is arbitrary, but it shall be the same for all six measurements.

**5.2.2.2** Designate the maximum response value as  $S_{\max}$ ; the minimum value as  $S_{\min}$ .

### 5.2.3 Requirements

**5.2.3.1** The lower response value  $S_{\min}$  shall be not less than 25  $\mu\text{l/l}$ .

**5.2.3.2** The ratio of the response values  $S_{\max} : S_{\min}$  shall be not greater than 1,6.

**Table 1 — Test schedule**

Test	Clause	Specimen No(s)
Repeatability of CO response	<a href="#">5.2</a>	one chosen arbitrarily
Directional dependence of CO response	<a href="#">5.3</a>	one chosen arbitrarily
Directional dependence of heat response	<a href="#">5.4</a>	one chosen arbitrarily
Lower limit of heat sensitivity	<a href="#">5.5</a>	1
Reproducibility of CO response	<a href="#">5.6</a>	all specimens
Reproducibility of heat sensitivity	<a href="#">5.7</a>	all specimens

<sup>a</sup> In the interests of test economy, it is permitted to use the same specimen for more than one EMC test. In that case, intermediate functional test(s) on the specimen(s) used for more than one test may be deleted, and the full functional test conducted at the end of the sequence of tests. However, it should be noted that in the event of a failure, it might not be possible to identify which test exposure caused the failure.

**Table 1** (continued)

Test	Clause	Specimen No(s)
Exposure to chemical agents at environmental concentrations	<a href="#">5.8</a>	1
Long term stability of CO response	<a href="#">5.9</a>	2
Saturation	<a href="#">5.10</a>	3
Exposure to chemical agents which may be present during a fire	<a href="#">5.11</a>	4
Variation in supply parameters	<a href="#">5.12</a>	5
Air movement	<a href="#">5.13</a>	6
Dry heat (operational)	<a href="#">5.14</a>	7
Dry heat (endurance)	<a href="#">5.15</a>	8
Cold (operational)	<a href="#">5.16</a>	9
Damp heat, cyclic (operational)	<a href="#">5.17</a>	10
Damp heat, steady-state (endurance)	<a href="#">5.18</a>	11
Low humidity, steady-state (endurance)	<a href="#">5.19</a>	12
Sulfur dioxide SO <sub>2</sub> corrosion (endurance)	<a href="#">5.20</a>	13
Shock (operational)	<a href="#">5.21</a>	14
Impact (operational)	<a href="#">5.22</a>	15
Vibration, sinusoidal (operational)	<a href="#">5.23</a>	16
Vibration, sinusoidal (endurance)	<a href="#">5.24</a>	16
Electromagnetic compatibility (EMC) immunity tests (operational)	<a href="#">5.25</a>	
a) electrostatic discharge		17
b) radiated electromagnetic fields		18
c) conducted disturbances induced by electromagnetic fields		19
d) fast transient bursts		20
e) slow high-energy voltage surge		21
Fire sensitivity	<a href="#">5.26</a>	22, 23, 24, 25
<p><sup>a</sup> In the interests of test economy, it is permitted to use the same specimen for more than one EMC test. In that case, intermediate functional test(s) on the specimen(s) used for more than one test may be deleted, and the full functional test conducted at the end of the sequence of tests. However, it should be noted that in the event of a failure, it might not be possible to identify which test exposure caused the failure.</p>		

### 5.3 Directional dependence of CO response

#### 5.3.1 Object of the test

To confirm that the CO sensitivity of the detector is not unduly dependent on the direction of airflow around the detector.

#### 5.3.2 Test procedure

**5.3.2.1** Measure the CO response value of the specimen to be tested eight times as specified in [5.1.5](#), the specimen being rotated 45° about its vertical axis between each measurement, so that the measurements are taken for eight different orientations relative to the direction of airflow.

**5.3.2.2** Designate the maximum CO response value as  $S_{\max}$ ; the minimum value as  $S_{\min}$ .

**5.3.2.3** Record the least sensitive and the most sensitive orientations. The orientation for which the maximum CO response is measured is referred to as the least sensitive orientation, and the orientation for which the minimum CO response is measured is referred to as the most sensitive orientation.

### **5.3.3 Requirements**

**5.3.3.1** The lower CO response value  $S_{\min}$  shall be not less than 25  $\mu\text{l/l}$ .

**5.3.3.2** The ratio of the CO response values  $S_{\max} : S_{\min}$  shall be not greater than 1,6.

## **5.4 Directional dependence of heat response**

### **5.4.1 Object of the test**

To confirm that the heat sensitivity of the detector is not unduly dependent on the direction of airflow around the detector.

### **5.4.2 Test procedure**

**5.4.2.1** Measure the heat response value of the specimen to be tested eight times as specified in [5.1.6](#) at a rate of rise of air temperature of 10 K/min, the specimen being rotated about a vertical axis by 45° between each measurement, so that the measurements are taken for eight different orientations relative to the direction of airflow. Stabilize the specimen at 25 °C before each measurement.

**5.4.2.2** Record the heat response value at each of the eight orientations.

**5.4.2.3** Designate the maximum heat response value as  $T_{\max}$ ; the minimum value as  $T_{\min}$ .

**5.4.2.4** Record the maximum heat response value and the minimum heat response value orientations. The orientation for which the maximum response time, or the minimum change in signal level was measured is referred to as the *least sensitive* heat orientation. The orientation for which the minimum response time, or the maximum change in signal level was measured is referred to as the *most sensitive* heat orientation.

### **5.4.3 Requirements**

The ratio of the heat response values  $T_{\max} : T_{\min}$  shall not be greater than 1,3, or shall not be greater than the value for which the manufacturer can demonstrate that the resulting change in the CO response value is not more than a factor of 1,6.

## **5.5 Lower limit of heat sensitivity**

### **5.5.1 Object of the test**

To confirm that detectors are not more sensitive to heat alone, without the presence of CO, than is permitted in ISO 7240-5.

### **5.5.2 Test procedure**

Measure the heat response value of the specimen to be tested, in its most sensitive orientation, using the methods described in ISO 7240-5:2012, 5.3 and 5.4 but with the test being terminated when an air

temperature of 55 °C has been reached. For the purposes of these tests, the test parameters for Class A1 detectors shall be used.

NOTE It is important to limit the temperature of the detector to 55 °C to prevent possible damage to the CO sensor using an electro-chemical cell.

### 5.5.3 Requirements

5.5.3.1 In the test for static response temperature, the specimen shall not give an alarm signal at a temperature less than 54 °C.

5.5.3.2 The specimen shall not give an alarm signal at any rate of rise of air temperature in a time less than the lower response time limits specified in ISO 7240-5:2012, Table 4 for a Class A1 detector.

## 5.6 Reproducibility of CO response

### 5.6.1 Object of the test

To show that the sensitivity of the detector does not vary unduly from specimen to specimen and to establish CO response value data for comparison with CO response values measured after the environmental tests.

### 5.6.2 Test procedure

5.6.2.1 Measure the CO response value of each of the test specimens as specified in [5.1.5](#).

5.6.2.2 Calculate the mean of these response values, which shall be designated  $\bar{S}$ .

5.6.2.3 Designate the maximum response value as  $S_{\max}$ ; the minimum value as  $S_{\min}$ .

### 5.6.3 Requirements

5.6.3.1 The lower CO response value  $S_{\min}$  shall be not less than 25 µl/l.

5.6.3.2 The ratio of the CO response values  $S_{\max} : \bar{S}$  shall not be greater than 1,33, and the ratio of the CO response values  $\bar{S} : S_{\min}$  shall not be greater than 1,5.

## 5.7 Reproducibility of heat response

### 5.7.1 Object of the test

To show that the heat sensitivity of the detector does not vary unduly from specimen to specimen and to establish heat response value data for comparison with the heat response values measured after the environmental tests.

### 5.7.2 Test procedure

5.7.2.1 Measure the heat response value of each of the test specimens as specified in [5.1.6](#) at a rate of rise of air temperature of 20 K/min and record the heat response value.

5.7.2.2 Designate the maximum heat response value as  $T_{\max}$ ; the minimum value as  $T_{\min}$ .

### 5.7.3 Requirements

The ratio of the heat response values  $T_{\max} : T_{\min}$  shall not be greater than 1,3, or shall not be greater than the value for which the manufacturer can demonstrate that the resulting change in the CO response value is not more than a factor of 1,6.

## 5.8 Exposure to chemical agents at environmental concentrations

### 5.8.1 Object of the test

To demonstrate the ability of the detector to withstand the effects of exposure to atmospheric pollutants or chemicals which may be encountered in the service environment.

### 5.8.2 Test procedure

**5.8.2.1** Install the specimen to be tested in a gas test chamber, as specified in [Annex A](#), in its normal operating position, by its normal means of attachment. Orient the specimen, relative to the direction of gas flow, to the most sensitive orientation, as determined in the directional dependence test.

**5.8.2.2** Before commencing each measurement, purge the gas test chamber to ensure that the carbon monoxide concentration and test gas concentration are less than 1 µl/l prior to each test.

**5.8.2.3** The air velocity in the proximity of the specimen shall be  $(0,2 \pm 0,04)$  m/s during the measurement.

**5.8.2.4** The air temperature in the tunnel shall be  $(23 \pm 5)$  °C and shall not vary by more than 5 K for all the measurements on the specimen.

**5.8.2.5** Connect the specimen to its supply and monitoring equipment as specified in [5.1.3](#), and allow the specimen to stabilize for a period of at least 15 min, unless otherwise specified by the manufacturer.

**5.8.2.6** Introduce a single gas into the gas test chamber such that the gas concentration reaches the required concentration as specified in [Table 2](#) within 10 min. Allow the detectors to stabilize for a period of 1 h at the elevated gas concentration. Where the CO response value is adjustable, the cross sensitivity shall be tested at the maximum sensitivity setting provided.

**5.8.2.7** Purge the gas test chamber at the completion of each test period.

### 5.8.3 Requirements

No alarm or fault signals shall be given during the conditioning.

**Table 2 — Gas and vapour concentrations**

Test	Chemical Agent	Concentration $\mu\text{l/l}$ $\pm 20\%$	Exposure period h	Recovery period h
1	Carbon monoxide	15	24	1-2
2	Nitrogen dioxide	5	24	1-2
3	Sulfur dioxide	5	24	1-2
4	Chlorine	2	1	1-2
5	Ammonia	50	1	1-2
6	Heptane	100	1	1-2
7	Ethanol	500	1	24-25
8	Acetone	1 500	1	24-25
9	Hexamethyldisiloxane	10	1	1-2
10	Ozone <sup>a</sup>	0,2	1	1-2

<sup>a</sup> The exposure to ozone need not be carried for sensor technologies that are known to be unaffected by this gas (e.g. electrochemical cells).

## 5.9 Long-term stability of CO response

### 5.9.1 Object of the test

To confirm that the CO response of the detector is stable over long periods of time.

### 5.9.2 Test procedure

**5.9.2.1** Connect the specimen to be tested to its supply and monitoring equipment as specified in [5.1.3](#) and operate in standard atmospheric conditions for a period of 84 d. Measure the CO response value, as described in [5.1.5](#), at 28 d, 56 d, and 84 d from the start of the test.

**5.9.2.2** Designate the highest of the CO response value measured in this test and that measured for the same specimen in the reproducibility test as  $S_{\max}$ . Designate the lowest of the values measured in this test and that measured for the same detector in the reproducibility test as  $S_{\min}$ .

### 5.9.3 Requirements

**5.9.3.1** No alarm signal or fault signal shall be given during the test.

**5.9.3.2** The lower CO response value  $S_{\min}$  shall be not less than 25  $\mu\text{l/l}$ .

**5.9.3.3** The ratio of the CO response values  $S_{\max} : S_{\min}$  shall not be greater than 1,6.

## 5.10 Saturation

### 5.10.1 Object of the test

To show that the detector suffers no significant changes to its response behaviour after exposure to high levels of carbon monoxide gas.

## 5.10.2 Test procedure

**5.10.2.1** Install the specimen for which the saturation sensitivity is to be measured in a gas test chamber, specified in [Annex A](#), in its normal operating position, by its normal means of attachment. The orientation of the specimen, relative to the direction of gas flow, shall be the least sensitive orientation, as determined in the directional dependence test.

**5.10.2.2** Before commencing each measurement, purge the gas test chamber to ensure that the carbon monoxide concentration and test gas concentration is less than 1 µl/l prior to each test.

**5.10.2.3** The air velocity in the proximity of the specimen shall be  $(0,2 \pm 0,04)$  m/s during the measurement.

**5.10.2.4** The air temperature in the tunnel shall be  $(23 \pm 5)$  °C and shall not vary by more than 5 K for all the measurements on the specimen.

**5.10.2.5** Connect the specimen to its supply and monitoring equipment as specified in [5.1.3](#), and allow it to stabilize for a period of at least 15 min, unless otherwise specified by the manufacturer.

**5.10.2.6** Introduce carbon monoxide gas into the chamber such that the rate of increase of gas concentration is 50 µl/l/min to a concentration of 500 µl/l. Maintain the gas concentration for a period of 1 h.

**5.10.2.7** During the last five minutes of the conditioning, reset the detector in accordance with the manufacturer's instructions.

**5.10.2.8** After a recovery period of 4 h at the standard atmospheric conditions, reset the detector and measure the CO response value as specified in [5.1.5](#).

**5.10.2.9** Designate the greater of the CO response value measured in this test and that measured for the same specimen in the reproducibility test as  $S_{\max}$  and the lesser as  $S_{\min}$ .

## 5.10.3 Requirements

**5.10.3.1** The detector shall remain in the alarm condition during the conditioning and shall generate an alarm signal within 1 min of being reset at the end of the conditioning period.

**5.10.3.2** The lower CO response value  $S_{\min}$  shall be not less than 25 µl/l.

**5.10.3.3** The ratio of the CO response values  $S_{\max} : S_{\min}$  shall not be greater than 1,6.

## 5.11 Exposure to chemical agents which may be present during a fire

### 5.11.1 Object of the test

To demonstrate that chemical agents that may be present during a fire do not unduly affect the ability of the detector to detect the CO produced by the fire, nor cause permanent changes in sensitivity.

### 5.11.2 Test procedure

**5.11.2.1** Install the specimen for which the CO response value is to be measured in the gas test chamber specified in [Annex A](#), in its normal operating position, by its normal means of attachment. The orientation of the specimen, relative to the direction of gas flow, shall be the least sensitive orientation, as determined in the directional dependence test.

5.11.2.2 Before commencing each measurement, purge the gas test chamber to ensure that the carbon monoxide concentration is less than 1 µl/l prior to each test.

5.11.2.3 The air velocity in the proximity of the specimen shall be  $(0,2 \pm 0,04)$  m/s during the measurement.

5.11.2.4 The air temperature in the tunnel shall be  $(23 \pm 5)$  °C and shall not vary by more than 5 K for all the measurements on a particular detector type.

5.11.2.5 Connect the specimen to its supply and monitoring equipment as specified in 5.1.3, and allow it to stabilize for a period of at least 15 min, unless otherwise specified by the manufacturer.

5.11.2.6 Introduce a single gas into the gas test chamber such that the gas concentration reaches the required concentration as specified in Table 3 within 10 min. Allow the detectors to stabilize for the duration of the exposure period in Table 3 at the elevated gas concentration.

5.11.2.7 Purge the gas test chamber at the completion of each test period and reset the detector, if an alarm has been signalled.

Table 3 — Gas

Substance	Concentration µl/l	Exposure period h
Carbon dioxide	5 000	1
Nitrogen dioxide	50	0.5
Sulfur dioxide	50	0.5

5.11.2.8 Following each exposure, after a recovery period of between 1 h and 2 h at the standard laboratory conditions, the CO response value shall be measured as described in 5.1.5.

5.11.2.9 Designate the greater of the CO response value measured in this test and that measured for the same specimen in the reproducibility test as  $S_{\max}$  and the lesser as  $S_{\min}$ .

### 5.11.3 Requirements

5.11.3.1 No fault signal shall be given during the conditioning.

5.11.3.2 The lower CO response value  $S_{\min}$  shall be not less than 25 µl/l.

5.11.3.3 The ratio of the CO response values  $S_{\max} : S_{\min}$  shall not be greater than 1,6.

## 5.12 Variation in supply parameters

### 5.12.1 Object of the test

To show that within the specified range(s) of the supply parameters (e.g. voltage), the sensitivity of the detector is not unduly dependent on these parameters.

### 5.12.2 Test procedure

5.12.2.1 Measure the CO response value of the specimen to be tested as specified in 5.1.5, at the upper and lower limits of the supply parameter (e.g. voltage) range(s) specified by the manufacturer.



**5.12.2.2** Designate the maximum CO response value as  $S_{\max}$ ; the minimum value as  $S_{\min}$ .

**5.12.2.3** Measure the heat response value of the specimen to be tested as specified in 5.1.6 at a rate of rise of air temperature of 20 K/min at the upper and lower limits of the supply parameter (e.g. voltage) range(s) specified by the manufacturer.

**5.12.2.4** Designate the maximum heat response value as  $T_{\max}$ ; the minimum value as  $T_{\min}$ .

NOTE For non-addressable (conventional) detectors, the supply parameter is the DC voltage applied to the detector. For other types of detector (e.g. analogue addressable), signal levels and timing might need to be considered. If necessary, the manufacturer can be requested to provide suitable supply equipment to allow the supply parameters to be changed as required.

### 5.12.3 Requirements

**5.12.3.1** The lower CO response value  $S_{\min}$  shall be not less than 25 µl/l.

**5.12.3.2** The ratio of the CO response values  $S_{\max} : S_{\min}$  shall not be greater than 1,6.

**5.12.3.3** The ratio of the heat response values  $T_{\max} : T_{\min}$  shall not be greater than 1,3, or shall not be greater than the value for which the manufacturer can demonstrate that the resulting change in the CO response value is not more than a factor of 1,6.

## 5.13 Air movement

### 5.13.1 Object of the test

To show that the CO sensitivity of the detector is not unduly affected by the rate of the airflow.

### 5.13.2 Test procedure

**5.13.2.1** Measure the CO response value of the specimen to be tested as specified in 5.1.5 in the most and least sensitive orientations as determined in 5.3. Designate these as  $S_{(0,2)\min}$  and  $S_{(0,2)\max}$ , respectively.

**5.13.2.2** Repeat these measurements, but with an air velocity in the proximity of the detector of  $(1 \pm 0,2)$  m/s. Designate the CO response values in the most and least sensitive orientations in these tests as  $S_{(1,0)\min}$  and  $S_{(1,0)\max}$ , respectively.

**5.13.2.3** Record any signal.

### 5.13.3 Requirements

**5.13.3.1** Formula (1) shall apply:

$$0,625 \leq \frac{S_{(0,2)\max} + S_{(0,2)\min}}{S_{(1,0)\max} + S_{(1,0)\min}} \leq 1,6 \quad (1)$$

**5.13.3.2** The detector shall not emit either a fault signal or an alarm signal during the test with gas-free air.

## 5.14 Dry heat (operational)

### 5.14.1 Object of the test

To demonstrate the ability of the detector to function correctly at high ambient temperatures appropriate to the anticipated service environment.

### 5.14.2 Test procedure

#### 5.14.2.1 Reference

Use the test apparatus and perform the procedure as specified in IEC 60068-2-2, Test Bb, and in [5.14.2.2](#) to [5.14.2.5](#).

#### 5.14.2.2 State of the specimen(s) during conditioning

Mount the specimen to be tested in the heat tunnel as specified in [5.1.6](#), in its least sensitive orientation and connect it to its supply and monitoring equipment as specified in [5.1.3](#).

#### 5.14.2.3 Conditioning

Apply the following conditioning:

- temperature:  $(55 \pm 2) \text{ }^\circ\text{C}$  [starting at an initial air temperature of  $(23 \pm 5) \text{ }^\circ\text{C}$ ];
- duration: 2 h.

NOTE Test Bb specifies rates of change of temperature of  $\leq 1 \text{ K/min}$  for the transitions to and from the conditioning temperature.

#### 5.14.2.4 Measurements during conditioning

Monitor the specimen during the conditioning period to detect any alarm or fault signals.

#### 5.14.2.5 Final measurements

**5.14.2.5.1** Measure the CO response value as specified in [5.1.5](#), but at a temperature of  $(55 \pm 2) \text{ }^\circ\text{C}$ .

**5.14.2.5.2** Designate the greater of the CO response value measured in this test and that measured for the same specimen in the reproducibility test as  $S_{\max}$ , the lesser as  $S_{\min}$ .

### 5.14.3 Requirements

**5.14.3.1** No alarm or fault signals shall be given during the period that the temperature is increasing to the conditioning temperature or during the conditioning period until the CO response value is measured.

**5.14.3.2** The lower CO response value  $S_{\min}$  shall be not less than  $25 \text{ } \mu\text{l/l}$ .

**5.14.3.3** The ratio of the CO response values  $S_{\max} : S_{\min}$  shall not be greater than 1,6.

## 5.15 Dry heat endurance

### 5.15.1 Object

To demonstrate the ability of the detector to withstand the long term effects of high temperature in the service environment (e.g. changes in electrical properties of materials, chemical reactions, etc.).

## 5.15.2 Test procedure

### 5.15.2.1 Reference

Use the test apparatus and perform the procedure as described in and IEC 60068-2-2, Tests for non-heat-dissipating specimens (i.e. Tests Ba or Bb), and in [5.15.2.2](#) to [5.15.2.3](#).

NOTE Test Ba (with sudden changes in temperature) may be used, to improve test economy, if it is known that the sudden change in temperature will not be detrimental to the specimen.

### 5.15.2.2 State of the specimen during conditioning

Mount the specimen as specified in [5.1.2](#), but do not supply it with power during the conditioning.

### 5.15.2.3 Conditioning

Apply the following conditioning:

temperature:  $(50 \pm 2)$  °C;

duration: 21 d.

### 5.15.2.4 Final measurements

**5.15.2.4.1** After a recovery period, of between 1 h and 2 h in standard laboratory conditions, measure the CO response value as described in [5.1.5](#).

**5.15.2.4.2** Designate the greater of the CO response value measured in this test and that measured for the same specimen in the reproducibility test as  $S_{\max}$  and the lesser as  $S_{\min}$ .

**5.15.2.4.3** Test the heat response value of the specimen as specified in [5.1.6](#) at a rate of rise of air temperature of 20 K/min at the upper and lower limits of the supply parameter (e.g. voltage) range(s) specified by the manufacturer.

**5.15.2.4.4** Designate the maximum heat response value as  $T_{\max}$  and the minimum value as  $T_{\min}$ .

## 5.15.3 Requirements

**5.15.3.1** No alarm or fault signals shall be given during the transition to the conditioning temperature or during the period at the conditioning temperature until the CO response value is measured.

**5.15.3.2** The lower CO response value  $S_{\min}$  shall be not less than 25 µl/l.

**5.15.3.3** The ratio of the CO response values  $S_{\max} : S_{\min}$  shall not be greater than 1,6.

**5.15.3.4** The ratio of the heat response values  $T_{\max} : T_{\min}$  shall not be greater than 1,3, or shall not be greater than the value for which the manufacturer can demonstrate that the resulting change in the CO response value is not more than a factor of 1,6.

## 5.16 Cold (operational)

### 5.16.1 Object of the test

To demonstrate the ability of the detector to function correctly at low ambient temperatures appropriate to the anticipated service environment.

## 5.16.2 Test procedure

### 5.16.2.1 Reference

The test apparatus and procedure shall be as specified in IEC 60068-2-1, Test Ab, and in [5.16.2.2](#) to [5.16.2.5](#).

### 5.16.2.2 State of the specimen(s) during conditioning

Mount the specimen to be tested as specified in [5.1.2](#) and connect it to its supply and monitoring equipment as specified in [5.1.3](#).

### 5.16.2.3 Conditioning

Apply the following conditioning:

temperature:  $(-10 \pm 3) ^\circ\text{C}$ ;

duration: 2 h.

NOTE Test Ab specifies rates of change of temperature of  $\leq 1$  K/min for the transitions to and from the conditioning temperature.

### 5.16.2.4 Measurements during conditioning

Monitor the specimen during the conditioning period to detect any alarm or fault signals.

### 5.16.2.5 Final measurements

**5.16.2.5.1** Measure the CO response value as specified in [5.1.5](#), except that the air temperature in the gas test chamber shall be  $(-10 \pm 3) ^\circ\text{C}$ .

**5.16.2.5.2** Designate the greater of the CO response value measured in this test and that measured for the same specimen in the reproducibility test as  $S_{\max}$ , the lesser as  $S_{\min}$ .

**5.16.2.5.3** After a recovery period of between 1 h and 2 h at the standard atmospheric conditions, measure the heat response value as described in [5.1.6](#) at a rate of rise of air temperature of 20 K/min.

**5.16.2.5.4** Designate the greater of the heat response values measured in this test and that measured for the same specimen in the reproducibility test,  $T_{\max}$  the lesser as  $T_{\min}$ .

## 5.16.3 Requirements

**5.16.3.1** No alarm or fault signals shall be given during the transition to the conditioning temperature or during the period at the conditioning temperature until the CO response value is measured.

**5.16.3.2** The lower CO response value  $S_{\min}$  shall be not less than 25  $\mu\text{l/l}$ .

**5.16.3.3** The ratio of the CO response values  $S_{\max} : S_{\min}$  shall not be greater than 1,6.

**5.16.3.4** The ratio of the heat response values  $T_{\max} : T_{\min}$  shall not be greater than 1,3, or shall not be greater than the value for which the manufacturer can demonstrate that the resulting change in the CO response value is not more than a factor of 1,6.

## 5.17 Damp heat, cyclic (operational)

### 5.17.1 Object

To demonstrate the ability of the detector to function correctly at high relative humidity (with condensation), which can occur for short periods in the anticipated service environment.

### 5.17.2 Test procedure

#### 5.17.2.1 Reference

Use the test apparatus and procedure as described in IEC 60068-2-30, Test Db using the Variant 1 test cycle and in [5.17.2.2](#) to [5.17.2.5](#).

#### 5.17.2.2 State of the specimen during conditioning

Mount the specimen to be tested as described in [5.1.2](#) and connect it to supply and monitoring equipment as described in [5.1.3](#).

#### 5.17.2.3 Conditioning

Apply the following conditioning (IEC 60068-2-30 Severity 1):

minimum temperature:	(25 ± 3) °C;
maximum temperature:	(40 ± 2) °C;
relative humidity:	
a) at minimum temperature:	≥ 95%,
b) at maximum temperature:	(93 ± 3) %;
number of cycles:	2;
duration:	2 d.

#### 5.17.2.4 Measurements during conditioning

Monitor the specimen during the conditioning period to detect any alarm or fault signals.

#### 5.17.2.5 Final measurements

After a recovery period of between 1 h and 2 h at the standard atmospheric conditions, measure the following.

- a) The CO response value as described in [5.1.5](#).

Designate the greater of the CO response value measured in this test and that measured for the same specimen in the reproducibility test,  $S_{\max}$ , the lesser as  $S_{\min}$ .

- b) The heat response value as described in [5.1.6](#) at a rate of rise of air temperature of 20 K/min.

Designate the greater of the heat response values measured in this test and that measured for the same specimen in the reproducibility test,  $T_{\max}$ , the lesser as  $T_{\min}$ .

### 5.17.3 Requirements

**5.17.3.1** No alarm or fault signal shall be given during the conditioning until the CO response value is measured.

**5.17.3.2** The lower CO response value  $S_{\min}$  shall be not less than 25  $\mu\text{l/l}$ .

**5.17.3.3** The ratio of the CO response values  $S_{\max} : S_{\min}$  shall not be greater than 1,6.

**5.17.3.4** The ratio of the heat response values  $T_{\max} : T_{\min}$  shall not be greater than 1,3, or shall not be greater than the value for which the manufacturer can demonstrate that the resulting change in the CO response value is not more than a factor of 1,6.

## **5.18 Damp heat, steady-state (endurance)**

### **5.18.1 Object of the test**

To demonstrate the ability of the detector to withstand the long-term effects of humidity in the service environment (e.g. changes in electrical properties of materials, chemical reactions involving moisture, galvanic corrosion etc.).

### **5.18.2 Test procedure**

#### **5.18.2.1 Reference**

Use the test apparatus and perform the procedure as specified in IEC 60068-2-78, Test Cab, and in [5.18.2.2](#) to [5.18.2.4](#).

#### **5.18.2.2 State of the specimen(s) during conditioning**

Mount the specimen to be tested as specified in [5.1.2](#), but do not supply it with power during the conditioning.

#### **5.18.2.3 Conditioning**

Apply the following conditioning:

temperature:  $(40 \pm 2) \text{ }^\circ\text{C}$ ;

relative humidity:  $(93 \pm 3) \%$ ;

duration: 21 d.

#### **5.18.2.4 Final measurements**

After a recovery period of between 1 h and 2 h at the standard atmospheric conditions, measure the following:

a) The CO response value as described in [5.1.5](#).

Designate the greater of the CO response value measured in this test and that measured for the same specimen in the reproducibility test,  $S_{\max}$ , the lesser as  $S_{\min}$ .

b) The heat response value as described in [5.1.6](#) at a rate of rise of air temperature of 20 K/min.

Designate the greater of the heat response values measured in this test and that measured for the same specimen in the reproducibility test,  $T_{\max}$ , the lesser as  $T_{\min}$ .

### **5.18.3 Requirements**

**5.18.3.1** No fault signal, attributable to the endurance conditioning, shall be given on reconnection of the specimen.

**5.18.3.2** The lower CO response value  $S_{\min}$  shall be not less than 25  $\mu\text{l/l}$ .

**5.18.3.3** The ratio of the CO response values  $S_{\max} : S_{\min}$  shall not be greater than 1,6.

**5.18.3.4** The ratio of the heat response values  $T_{\max} : T_{\min}$  shall not be greater than 1,3, or shall not be greater than the value for which the manufacturer can demonstrate that the resulting change in the CO response value is not more than a factor of 1,6.

## **5.19 Low humidity, steady-state (endurance)**

### **5.19.1 Object of the test**

To demonstrate the ability of the detector to withstand long periods of low humidity in the service environment.

NOTE This test evaluates the resistance to the drying out of electrolyte in electrochemical cells.

### **5.19.2 Test procedure**

#### **5.19.2.1 State of the specimen during conditioning**

Mount the specimen to be tested as described in [5.1.2](#), but do not supply it with power during the conditioning.

#### **5.19.2.2 Conditioning**

Apply the following conditioning:

temperature:	(25 $\pm$ 3) °C;
relative humidity:	(11 $\pm$ 1) %;
duration:	21 d.

NOTE The relative humidity specified for this test can be maintained using a saturated solution of lithium chloride inside a sealed enclosure.

#### **5.19.2.3 Final measurements**

**5.19.2.3.1** After a recovery period of between 1 h and 2 h in standard atmospheric conditions, measure the CO response value as described in [5.1.5](#).

**5.19.2.3.2** The greater of the CO response value measured in this test and that measured for the same specimen in the reproducibility test, shall be designated  $S_{\max}$ , and the lesser shall be designated  $S_{\min}$ .

### **5.19.3 Requirements**

**5.19.3.1** No fault signal, attributable to the endurance conditioning, shall be given on reconnection of the specimen.

**5.19.3.2** The lower CO response value  $S_{\min}$  shall be not less than 25  $\mu\text{l/l}$ .

**5.19.3.3** The ratio of the CO response values  $S_{\max} : S_{\min}$  shall not be greater than 1,6.

## 5.20 Sulfur dioxide SO<sub>2</sub> corrosion (endurance)

### 5.20.1 Object of the test

To demonstrate the ability of the detector to withstand the corrosive effects of sulfur dioxide as an atmospheric pollutant.

### 5.20.2 Test procedure

#### 5.20.2.1 Reference

Use the test apparatus and procedure generally specified in IEC 60068-2-42, Test Kc, but carry out the conditioning specified in [5.20.2.3](#).

#### 5.20.2.2 State of the specimen during conditioning

Mount the specimen to be tested as specified in [5.1.2](#). Do not supply it with power during the conditioning, but equip it with untinned copper wires, of the appropriate diameter, connected to sufficient terminals, to allow the final measurement to be made, without making further connections to the specimen.

#### 5.20.2.3 Conditioning

Apply the following conditioning:

temperature:	(25 ± 2) °C;
relative humidity:	(93 ± 3) %;
SO <sub>2</sub> concentration:	(25 ± 5) µl/l;
duration:	21 d.

#### 5.20.2.4 Final measurements

Immediately after the conditioning, subject the specimen to a drying period of 16 h at (40 ± 2) °C, ≤ 50 % RH, followed by a recovery period of at least 1 h at the standard atmospheric conditions. After this, measure the following:

- a) The CO response value as described in [5.1.5](#).

Designate the greater of the CO response value measured in this test and that measured for the same specimen in the reproducibility test,  $S_{\max}$ , the lesser as  $S_{\min}$ .

- b) The heat response value as described in [5.1.6](#) at a rate of rise of air temperature of 20 K/min.

Designate the greater of the heat response values measured in this test and that measured for the same specimen in the reproducibility test,  $T_{\max}$ , the lesser as  $T_{\min}$ .

### 5.20.3 Requirements

**5.20.3.1** No fault signal, attributable to the endurance conditioning, shall be given on reconnection of the specimen.

**5.20.3.2** The lower CO response value  $S_{\min}$  shall be not less than 25 µl/l.

**5.20.3.3** The ratio of the CO response values  $S_{\max} : S_{\min}$  shall not be greater than 1,6.



**5.20.3.4** The ratio of the heat response values  $T_{\max} : T_{\min}$  shall not be greater than 1,3, or shall not be greater than the value for which the manufacturer can demonstrate that the resulting change in the CO response value is not more than a factor of 1,6.

## **5.21 Shock (operational)**

### **5.21.1 Object of the test**

To demonstrate the immunity of the detector to mechanical shocks, which are likely to occur, albeit infrequently, in the anticipated service environment. This test is not performed on specimens with a mass > 4,75 kg.

### **5.21.2 Test procedure**

#### **5.21.2.1 Reference**

Use the test apparatus and procedure shall be as described in IEC 60068-2-27, Test Ea, but carry out the conditioning specified in [5.21.2.3](#).

#### **5.21.2.2 State of the specimen during conditioning**

Mount the specimen to be tested as described in [5.1.2](#) to a rigid fixture, and connect it to its supply and monitoring equipment as described in [5.1.3](#).

#### **5.21.2.3 Conditioning**

For specimens with a mass  $\leq 4,75$  kg apply the following conditioning:

shock pulse type:	Half sine;
pulse duration:	6 ms;
peak acceleration:	10 (100 - 20M) m/s <sup>2</sup> (where M is the specimen's mass in kg);
number of directions:	6;
pulses per direction:	3.

#### **5.21.2.4 Measurements during conditioning**

Monitor the specimen during the conditioning period and for a further 2 min to detect any alarm or fault signals.

#### **5.21.2.5 Final measurements**

After the conditioning, measure the following:

- a) The CO response value as described in [5.1.5](#).

Designate the greater of the CO response value measured in this test and that measured for the same specimen in the reproducibility test,  $S_{\max}$ , the lesser as  $S_{\min}$ .

- b) The heat response value as described in [5.1.6](#) at a rate of rise of air temperature of 20 K/min.

Designate the greater of the heat response values measured in this test and that measured for the same specimen in the reproducibility test,  $T_{\max}$ , the lesser as  $T_{\min}$ .

### 5.21.3 Requirements

**5.21.3.1** No alarm or fault signals shall be given during the conditioning or the additional 2 min after the end of conditioning ([5.21.2.4](#)).

**5.21.3.2** The lower CO response value  $S_{\min}$  shall be not less than 25  $\mu\text{l/l}$ .

**5.21.3.3** The ratio of the CO response values  $S_{\max} : S_{\min}$  shall not be greater than 1,6.

**5.21.3.4** The ratio of the heat response values  $T_{\max} : T_{\min}$  shall not be greater than 1,3, or shall not be greater than the value for which the manufacturer can demonstrate that the resulting change in the CO response value is not more than a factor of 1,6.

## 5.22 Impact (operational)

### 5.22.1 Object of the test

To demonstrate the immunity of the detector to mechanical impacts upon its surface, which it may sustain in the normal service environment, and which it can reasonably be expected to withstand.

### 5.22.2 Test procedure

#### 5.22.2.1 Apparatus

The test apparatus shall consist of a swinging hammer incorporating a rectangular-section aluminium alloy head (Aluminium alloy Al Cu<sub>4</sub>SiMg complying with ISO 209, solution treated and precipitation treated condition) with the plane impact face chamfered to an angle of 60° to the horizontal, when in the striking position (i.e. when the hammer shaft is vertical). The hammer head shall be (50 ± 2,5) mm high, (76 ± 3,8) mm wide and (80 ± 4) mm long at mid height as shown in [Figure C.1](#). A suitable apparatus is described in [Annex C](#).

#### 5.22.2.2 State of the specimen during conditioning

Mount the specimen to be tested rigidly to the apparatus by its normal mounting means and position it so that it is struck by the upper half of the impact face when the hammer is in the vertical position (i.e. when the hammerhead is moving horizontally). Choose the azimuthal direction and the position of impact relative to the specimen as that most likely to impair the normal functioning of the specimen. Connect the specimen to its supply and monitoring equipment as specified in [5.1.3](#).

#### 5.22.2.3 Conditioning

Use the following test parameters during the conditioning:

impact energy:	(1,9 ± 0,1) J;
hammer velocity:	(1,5 ± 0,13) m/s;
number of impacts:	1.

#### 5.22.2.4 Measurements during conditioning

Monitor the specimen during the conditioning period and for a further 2 min to detect any alarm or fault signals.

### 5.22.2.5 Final measurements

After the conditioning, measure the following:

- a) The CO response value as described in [5.1.5](#).

Designate the greater of the CO response value measured in this test and that measured for the same specimen in the reproducibility test,  $S_{\max}$ , the lesser as  $S_{\min}$ .

- b) The heat response value as described in [5.1.6](#) at a rate of rise of air temperature of 20 K/min.

Designate the greater of the heat response values measured in this test and that measured for the same specimen in the reproducibility test,  $T_{\max}$ , the lesser as  $T_{\min}$ .

### 5.22.3 Requirements

5.22.3.1 No alarm or fault signals shall be given during the conditioning or the additional 2 min.

5.22.3.2 The impact shall not detach the detector from its base, or the base from the mounting.

5.22.3.3 The lower CO response value  $S_{\min}$  shall be not less than 25  $\mu\text{l/l}$ .

5.22.3.4 The ratio of the CO response values  $S_{\max} : S_{\min}$  shall not be greater than 1,6.

5.22.3.5 The ratio of the heat response values  $T_{\max} : T_{\min}$  shall not be greater than 1,3, or shall not be greater than the value for which the manufacturer can demonstrate that the resulting change in the CO response value is not more than a factor of 1,6.

## 5.23 Vibration, sinusoidal, (operational)

### 5.23.1 Object of the test

To demonstrate the immunity of the detector to vibration at levels considered appropriate to the normal service environment.

### 5.23.2 Test procedure

#### 5.23.2.1 Reference

Use the test apparatus and procedure as described in IEC 60068-2-6, Test Fc, and in [5.23.2.2](#) to [5.23.2.5](#).

#### 5.23.2.2 State of the specimen during conditioning

5.23.2.2.1 Mount the specimen to be tested on a rigid fixture as specified in [5.1.2](#) and connect it to its supply and monitoring equipment as specified in [5.1.3](#).

5.23.2.2.2 Apply the vibration in each of three mutually perpendicular axes in turn, and so that one of the three axes is perpendicular to the normal mounting plane of the specimen.

#### 5.23.2.3 Conditioning

5.23.2.3.1 Apply the following conditioning:

frequency range: (10 to 150) Hz;

acceleration amplitude: 5  $\text{m/s}^2$  (approximately 0,5 gn);

number of axes:	3;
sweep rate:	1 octave/min;
number of sweep cycles:	1 per axis.

**5.23.2.3.2** The vibration operational and endurance tests may be combined such that the specimen is subjected to the operational test conditioning followed by the endurance test conditioning in one axis before changing to the next axis. Only one final measurement need be made.

#### **5.23.2.4 Measurements during conditioning**

Monitor the specimen during the conditioning period to detect any alarm or fault signals.

#### **5.23.2.5 Final measurements**

**5.23.2.5.1** The final measurements specified in [5.23.2.5](#) are normally made after the vibration endurance test and only need be made here if the operational test is conducted in isolation.

**5.23.2.5.2** The greater of the CO response value measured in this test and that measured for the same specimen in the reproducibility test, shall be designated  $S_{\max}$ , and the lesser shall be designated  $S_{\min}$ .

**5.23.2.5.3** The greater of the heat response values measured in this test and that measured for the same specimen in the reproducibility test, shall be designated  $T_{\max}$ , and the lesser shall be designated  $T_{\min}$ .

#### **5.23.3 Requirements**

**5.23.3.1** No alarm or fault signal, attributable to the endurance conditioning, shall be given on reconnection of the specimen.

**5.23.3.2** The lower CO response value  $S_{\min}$  shall be not less than 25  $\mu\text{l/l}$ .

**5.23.3.3** The ratio of the CO response values  $S_{\max} : S_{\min}$  shall not be greater than 1,6.

**5.23.3.4** The ratio of the heat response values  $T_{\max} : T_{\min}$  shall not be greater than 1,3, or shall not be greater than the value for which the manufacturer can demonstrate that the resulting change in the CO response value is not more than a factor of 1,6.

### **5.24 Vibration, sinusoidal (endurance)**

#### **5.24.1 Object of the test**

To demonstrate the ability of the detector to withstand the long term effects of vibration at levels appropriate to the service environment.

#### **5.24.2 Test procedure**

##### **5.24.2.1 Reference**

Use the test apparatus and perform the procedure as specified in IEC 60068-2-6, Test Fc, and [5.24.2.2](#) to [5.24.2.4](#).

### 5.24.2.2 State of the specimen during conditioning

5.24.2.2.1 Mount the specimen to be tested on a rigid fixture as described in 5.1.2, but do not supply it with power during conditioning.

5.24.2.2.2 Apply the vibration in each of three mutually perpendicular axes, in turn, and so that one of the three axes is perpendicular to its normal mounting axis of the specimen.

### 5.24.2.3 Conditioning

5.24.2.3.1 Apply the following conditioning:

frequency range:	(10 to 150) Hz;
acceleration amplitude:	10 m/s <sup>2</sup> (approximately 1,0 gn);
number of axes:	3;
sweep rate:	1 octave/min;
number of sweep cycles:	20 per axis.

5.24.2.3.2 The vibration operational and endurance tests may be combined such that the specimen is subjected to the operational test conditioning followed by the endurance test conditioning in one axis before changing to the next axis. Only one final measurement need be made.

### 5.24.2.4 Final measurements

After the conditioning measure the following:

a) The CO response value as described in 5.1.5.

Designate the greater of the CO response value measured in this test and that measured for the same specimen in the reproducibility test,  $S_{\max}$ , the lesser as  $S_{\min}$ .

b) The heat response value as described in 5.1.6 at a rate of rise of air temperature of 20 K/min.

Designate the greater of the heat response values measured in this test and that measured for the same specimen in the reproducibility test,  $T_{\max}$ , the lesser as  $T_{\min}$ .

### 5.24.3 Requirements

5.24.3.1 No fault signal, attributable to the endurance conditioning, shall be given on reconnection of the specimen.

5.24.3.2 The lower CO response value  $S_{\min}$  shall be not less than 25 µl/l.

5.24.3.3 The ratio of the CO response values  $S_{\max} : S_{\min}$  shall not be greater than 1,6.

5.24.3.4 The ratio of the heat response values  $T_{\max} : T_{\min}$  shall not be greater than 1,3, or shall not be greater than the value for which the manufacturer can demonstrate that the resulting change in the CO response value is not more than a factor of 1,6.

## 5.25 Electromagnetic Compatibility (EMC), Immunity tests (operational)

5.25.1 The following EMC immunity tests shall be carried out, as described in IEC 62599-2:

- a) electrostatic discharge;
- b) radiated electromagnetic fields;
- c) conducted disturbances induced by electromagnetic fields;
- d) fast transient bursts, at a repetition rate of 100 kHz;
- e) slow high-energy voltage surge.

**5.25.2** For these tests the criteria for compliance specified in IEC 62599-2 and the following shall apply.

- a) The functional test, called for in the initial and final measurements, shall be as follows:
  - Measure the CO response value as described in [5.1.5](#).
  - Designate the greater of the CO response value measured in this test and that measured for the same specimen in the reproducibility test,  $S_{\max}$ , the lesser as  $S_{\min}$ .
  - Measure the heat response value as described in [5.1.6](#) at a rate of rise of air temperature of 20 K/min.
  - Designate the greater of the heat response values measured in this test and that measured for the same specimen in the reproducibility test,  $T_{\max}$ , the lesser as  $T_{\min}$ .
- b) The required operating condition shall be as described in [5.1.3](#).
- c) The acceptance criteria for the functional test after the conditioning shall be as follows.
  - The lower CO response value  $S_{\min}$  shall be not less than 25  $\mu\text{l/l}$ ;
  - The ratio of the CO response values  $S_{\max} : S_{\min}$  shall not be greater than 1,6;
  - The ratio of the heat response values  $T_{\max} : T_{\min}$  shall not be greater than 1,3, or shall not be greater than the value for which the manufacturer can demonstrate that the resulting change in the CO response value is not more than a factor of 1,6.

## 5.26 Fire sensitivity

### 5.26.1 Object of the test

To show that the detector has adequate sensitivity to a broad spectrum of fire types as required for general application in fire detection systems for buildings.

### 5.26.2 Test procedure

#### 5.26.2.1 Principle

The specimens to be tested are mounted in a standard fire test room (see [Annex D](#)) and exposed to a series of test fires designed to produce smoke, heat, and CO representative of a wide spectrum of smoke and smoke flow conditions.

#### 5.26.2.2 Test fires

**5.26.2.2.1** Subject the specimens to the four test fires TF2, TF3, TF4, and TF5. The type, quantity, and arrangement of the fuel and the method of ignition are specified in [Annexes E to I](#) for each test fire, along with the end-of-test condition and the required profile curve limits.

**5.26.2.2.2** In order for a test fire to be valid, the development of the fire shall be such that the profile curves of  $m$  against  $y$  and  $m$  against time,  $t$  (for TF2, TF3, TF4, and TF5), fall within the specified limits,

up to the time when all of the specimens have generated an alarm signal or the end-of-test condition is reached, whichever is the earlier. If these conditions are not met, then the test is invalid and shall be repeated. It is permissible, and may be necessary, to adjust the quantity, condition (e.g. moisture content), and arrangement of the fuel to obtain valid test fires.

### 5.26.2.3 Mounting the specimens

**5.26.2.3.1** Mount the four specimens (Nos. 22, 23, 24, and 25) on the fire test room ceiling in the designated area (see [Annex D](#)) in accordance with the manufacturer's instructions, such that they are in the least sensitive orientation relative to an assumed airflow from the centre of the room to the specimen.

**5.26.2.3.2** Connect each specimen to its supply and monitoring equipment, as specified in [5.1.3](#), and allow it to stabilize in its quiescent condition before the start of each test fire.

**5.26.2.3.3** Detectors which dynamically modify their sensitivity in response to varying ambient conditions might require special reset procedures and/or stabilization times. The manufacturer's guidance should be sought in such cases to ensure that the state of the detectors at the start of each test is representative of their normal quiescent state.

### 5.26.2.4 Initial conditions

**IMPORTANT — The stability of the air and temperature affects the smoke flow and gas flow within the room. This is particularly important for the test fires that produce low thermal lift for the smoke (e.g. TF2 and TF3). Therefore, the difference between the temperature near the floor and the ceiling should be < 2 °C, and local heat sources that can cause convection currents (e.g. lights and heaters) should be avoided. If it is necessary for people to be in the room at the beginning of a test fire, they should leave as soon as possible, taking care to produce the minimum disturbance to the air.**

**5.26.2.4.1** Before each test fire, ventilate the room with clean air until it is free from smoke, so that the conditions given below can be obtained.

**5.26.2.4.2** Switch off the ventilation system and close all doors, windows and other openings. Then allow the air in the room to stabilize and the following conditions to be obtained before the test is started:

air temperature:	$T = (23 \pm 5) \text{ °C};$
air movement:	negligible;
smoke density (ionization):	$y \leq 0,05;$
smoke density (optical):	$m \leq 0,02 \text{ dB/m};$
CO concentration:	$S \leq 5 \text{ µl/l}.$

### 5.26.2.5 Recording of the fire parameters and response value

**5.26.2.5.1** During each test fire, record the fire parameters in [Table 4](#) as a function of time from the start of the test. Record each parameter continuously or at least once per second.

**Table 4 — Fire parameters**

Parameter	Symbol	Units
temperature change	$\Delta T$	°C
smoke density (ionization)	$y$	(dimensionless)
smoke density (optical)	$m$	dB/m
carbon monoxide concentration	$S$	$\mu\text{l/l}$

**5.26.2.5.2** The alarm signal given by the supply and monitoring equipment shall be taken as the indication that a specimen has responded to the test fire.

**5.26.2.5.3** Record the time of response (alarm signal) of each specimen, along with  $\Delta T$ ,  $y$ ,  $m$ , and  $S$ , the fire parameters at the moment of response. A response after the end-of-test condition is ignored.

### **5.26.2.6 Requirements**

All four specimens shall generate an alarm signal, in each test fire, before the specified end-of-test condition is reached.

## **6 Test report**

The test report shall contain, as a minimum, the following information:

- a) an identification of the specimen tested;
- b) a reference to this part of ISO 7240 (i.e. ISO 7240-8:2014);
- c) results of the test: the individual response values and the minimum, maximum, and arithmetic mean values where appropriate;
- d) conditioning period and the conditioning atmosphere;
- e) temperature and the relative humidity in the test room throughout the test;
- f) details of the supply and monitoring equipment and the alarm criteria;
- g) details of any deviation from this part of ISO 7240 or from the International Standards to which reference is made, and details of any operations regarded as optional.

## **7 Marking**

**7.1** Each detector shall be clearly marked with the following information:

- a) the number of this part of ISO 7240 (i.e. ISO 7240-8:2014);
- b) name or trademark of the manufacturer or supplier;
- c) model designation (type or number);
- d) wiring terminal designations;
- e) some mark(s) or code(s) (e.g. serial number or batch code), by which the manufacturer can identify, at least, the date or batch and place of manufacture, and the version number(s) of any software, contained within the detector.



f) life-expectancy of the CO sensor under normal operating conditions.

**7.2** For detachable detectors, the detector head shall be marked with a), b), c), e), and f), and the base shall be marked with at least c), i.e. its own model designation, and d).

**7.3** Where any marking on the device uses symbols or abbreviations not in common use, then these should be explained in the data supplied with the device.

**7.4** The marking shall be visible during installation of the detector and shall be accessible during maintenance.

**7.5** The markings shall not be placed on screws or other easily removable parts.

## **8 Data**

### **8.1 Hardware documentation**

**8.1.1** Detectors shall either be supplied with sufficient technical, installation, and maintenance data to enable their correct installation and operation or, if all of these data are not supplied with each detector, reference to the appropriate data sheet shall be given on or with each detector.

**8.1.2** To enable correct operation of the detectors, these data should describe the requirements for the correct processing of the signals from the detector. This may be in the form of a full technical specification of these signals, a reference to the appropriate signalling protocol, or a reference to suitable types of FDCIE, etc.

**8.1.3** Installation and maintenance data shall include reference to an *in situ* test method to ensure that detectors operate correctly when installed.

**NOTE** Additional information might be required by organizations certifying that detectors produced by a manufacturer conform to the requirements of this part of ISO 7240.

### **8.2 Software documentation**

**8.2.1** The manufacturer shall submit documentation that gives an overview of the software design. This documentation shall be in sufficient detail for the design to be inspected for compliance with this part of ISO 7240 and shall include at least the following:

- a) functional description of the main program flow (e.g. as a flow diagram or schema) including the following:
  - 1) a brief description of the modules and the functions that they perform;
  - 2) the way in which the modules interact;
  - 3) the overall hierarchy of the program;
  - 4) the way in which the software interacts with the hardware of the detector;
  - 5) the way in which the modules are called, including any interrupt processing;
- b) description of which areas of memory are used for the various purposes (e.g. the program, site-specific data, and running data);
- c) designation, by which the software and its version can be uniquely identified.

**8.2.2** The manufacturer shall prepare and maintain detailed design documentation. This shall be available for inspection in a manner that respects the manufacturers' rights for confidentiality. It shall comprise at least the following:

- a) overview of the whole system configuration, including all software and hardware components;
- b) description of each module of the program, containing at least
  - 1) name of the module,
  - 2) description of the tasks performed, and
  - 3) description of the interfaces, including the type of data transfer, the valid data range, and the checking for valid data;
- c) full source-code listings, as hard copy or in machine-readable form (e.g. ASCII-code), including all global and local variables, constants and labels used, and sufficient comment for the program flow to be recognized;
- d) details of any software tools used in the design and implementation phase (e.g. CASE-Tools, Compilers, etc.).

NOTE This detailed design documentation can be reviewed at the manufacturer's premises.

## Annex A (normative)

### Gas test chamber for CO response value and cross sensitivity measurements

**A.1** The following specifies those properties of the gas test chamber that are of primary importance for making repeatable and reproducible measurements of CO response values of fire detectors. However, since it is not practical to specify and measure all parameters which may influence the measurements, the background information in [Annex I](#) should be carefully considered and taken into account when a gas test chamber is designed and used to make measurements in accordance with this part of ISO 7240.

**A.2** The gas test chamber shall have a horizontal working section containing a working volume. The working volume is a defined part of the working section where the air temperature and airflow are within the required test conditions. Conformance with this requirement shall be regularly verified under static conditions, by measurements at an adequate number of points distributed within and on the imaginary boundaries of the working volume. The working volume shall be large enough to fully enclose the detector to be tested and the sensing parts of the measuring equipment. The detector to be tested shall be mounted in its normal operating position on the underside of a flat board aligned with the airflow in the working volume. The detector mounting board shall be of such dimensions that the edge(s) of the board are at least 20 mm from any part of the detector. The detector mounting arrangement shall not unduly obstruct the airflow between the board and the ceiling of the gas test chamber.

**A.3** Means shall be provided for creating an essentially laminar airflow at the required velocities [i.e.  $(0,2 \pm 0,04)$  m/s or  $(1,0 \pm 0,2)$  m/s] through the working volume. It shall be possible to maintain the temperature at the required values and to increase the temperature at a rate not exceeding 1 K/min from  $-10$  °C to 55 °C.

**A.4** Means shall be provided for the introduction of the test gas such that a homogeneous gas concentration is in the working volume.

**A.5** The response of CO fire detectors is characterized by the concentration of CO in air measured in the proximity of the detector, at the moment that it generates an alarm signal. Gas concentration measurements,  $S$ , shall be made in the working volume in the proximity of the detector.

**A.6** The instrument used for the measurement of CO shall have a measuring accuracy of at least 1 µl/l and better than 5 % of the measured CO concentration. The response time of the instrument shall be such that it does not cause a measurement error at the highest rate of increase used for measurements in the gas test chamber greater than 5 µl/l.

**A.7** Only one detector shall be mounted in the chamber, unless it has been demonstrated that measurements made simultaneously on more than one detector are in close agreement with measurements made by testing detectors individually. In the event of a dispute, the value obtained by individual testing shall be accepted.

## Annex B (normative)

### Heat tunnel for response time and response temperature measurements

**B.1** This Annex specifies those properties of the heat tunnel which are of primary importance for making repeatable and reproducible measurements of response time and static response temperature of heat detectors. However, since it is not practical to specify and measure all parameters which can influence the measurements, the background information in [Annex J](#) should be carefully considered and taken into account when a heat tunnel is designed and used to make measurements in accordance with this part of ISO 7240.

**B.2** The heat tunnel shall meet the requirements in [B.3](#) to [B.9](#) for each class of heat detector it is used to test.

**B.3** The heat tunnel (see [Figure J.1](#)) shall have a horizontal working section containing a working volume. The working volume is a defined part of the working section, where the air temperature and air flow conditions are within  $\pm 2$  K and  $\pm 0,1$  m/s, respectively, of the nominal test conditions. Conformance with this requirement shall be regularly verified under both static and rate-of-rise conditions by measurements at an adequate number of points distributed within and on the imaginary boundaries of the working volume. The working volume shall be large enough to fully enclose the detector(s) to be tested, the required amount of mounting board and the temperature measuring sensor.

**B.4** The detector to be tested shall be mounted in its normal operating position on the underside of a flat board aligned with the air flow in the working volume. The board shall be  $(5 \pm 1)$  mm thick and of such dimensions that the edge(s) of the board are at least 20 mm from any part of the detector. The edge(s) of the board shall have a semi-circular form and the air flow between the board and the tunnel ceiling shall not be unduly obstructed. The material from which the board is made shall have a thermal conductivity not greater than 0,52 W/m.K).

**B.5** If more than one detector is to be mounted in the working volume and tested simultaneously (see [Figure J.2](#)), then previous tests shall have been conducted, which confirm that response time measurements made simultaneously on more than one detector are in close agreement with measurements made by testing detectors individually. In the event of a dispute, the value obtained by individual testing shall be accepted.

**B.6** Means shall be provided for creating a stream of air through the working volume at the constant temperatures and rates of rise of air temperature specified for the classes of detector to be tested. This air stream shall be essentially laminar and maintained at a constant mass flow, equivalent to  $(0,8 \pm 0,1)$  m/s at 25 °C.

**B.7** The temperature sensor shall be positioned at least 50 mm upstream of the detector and at least 25 mm below the lower surface of the mounting board. The air temperature shall be controlled to within  $\pm 2$  K of the nominal temperature required at any time during the test.

**B.8** The air-temperature measuring system shall have an overall time constant of not greater than 2 s, when measured in air with a mass flow equivalent to  $(0,8 \pm 0,1)$  m/s at 25 °C.

**B.9** Means shall be provided for measuring the response time of the detector under test to an accuracy of  $\pm 1$  s.

## Annex C (normative)

### Apparatus for impact test

**C.1** The apparatus (see [Figure C.1](#)) consists essentially of a swinging hammer comprising a rectangular section head (striker) with a chamfered impact face, mounted on a tubular steel shaft. The hammer is fixed into a steel boss, which runs on ball bearings on a fixed steel shaft mounted in a rigid steel frame, so that the hammer can rotate freely about the axis of the fixed shaft. The design of the rigid frame is such as to allow complete rotation of the hammer assembly when the specimen is not present.

**C.2** The striker with overall dimensions of 76 mm (width) × 50 mm (depth) × 94 mm (length) and is manufactured from aluminium alloy (Al Cu<sub>4</sub>SiMg as specified in ISO 209-1), which has been solution and precipitation-treated. It has a plane-impact face chamfered at  $(60 \pm 1)^\circ$  to the long axis of the head. The tubular steel shaft has an outside diameter of  $(25 \pm 0,1)$  mm with a wall thickness of  $(1,6 \pm 0,1)$  mm.

**C.3** The striker is mounted on the shaft so that its long axis is at a radial distance of 305 mm from the axis of rotation of the assembly, the two axes being mutually perpendicular. The central boss is 102 mm in outside diameter and 200 mm long, and is mounted coaxially on the fixed steel pivot shaft, which is approximately 25 mm in diameter; however the precise diameter of the shaft will depend on the bearings used.

**C.4** Diametrically opposite the hammer shaft are two steel counter-balance arms, each 20 mm in outside diameter and 185 mm long. These arms are screwed into the boss so that the length of 150 mm protrudes. A steel counter-balance weight is mounted on the arms so that its position can be adjusted to balance the mass of the striker and arms, as in [Figure C.1](#). On the end of the central boss is mounted a 150 mm-diameter aluminium alloy pulley, 12 mm wide, and around this is wound an inextensible cable, with one end fixed to the pulley. The other end of the cable supports the operating weight.

**C.5** The rigid frame also supports the mounting board on which the specimen is mounted by its normal fixings. The mounting board is adjustable vertically so that the upper half of the impact face of the hammer will strike the specimen when the hammer is moving horizontally, as shown in [Figure C.1](#).

**C.6** To operate the apparatus, the position of the mounting board with the specimen is first adjusted as shown in [Figure C.1](#) and the mounting board is then secured rigidly to the frame. The hammer assembly is then balanced carefully by adjustment of the counter-balance weight with the operating weight removed. The hammer arm is then drawn back to the horizontal position ready for release and the operating weight is reinstated. On release of the assembly, the operating weight will spin the hammer and arm through an angle of  $3\pi/2$  rad to strike the specimen. The mass, in kilograms, of the operating weight to produce the required impact energy of 1,9 J equals  $0,388/(3\pi r)$  kg, where  $r$  is the effective radius of the pulley, in metres. This equals approximately 0,55 kg for a pulley radius of 75 mm.

**C.7** As this part of ISO 7240 requires a hammer velocity at impact of  $(1,5 \pm 0,13)$  m/s, the mass of the hammer head will need to be reduced by drilling the back face sufficiently to obtain this velocity. It is estimated that a head of mass of about 0,79 kg will be required to obtain the specified velocity, but this will have to be determined by trial and error.

Dimensions in millimetres

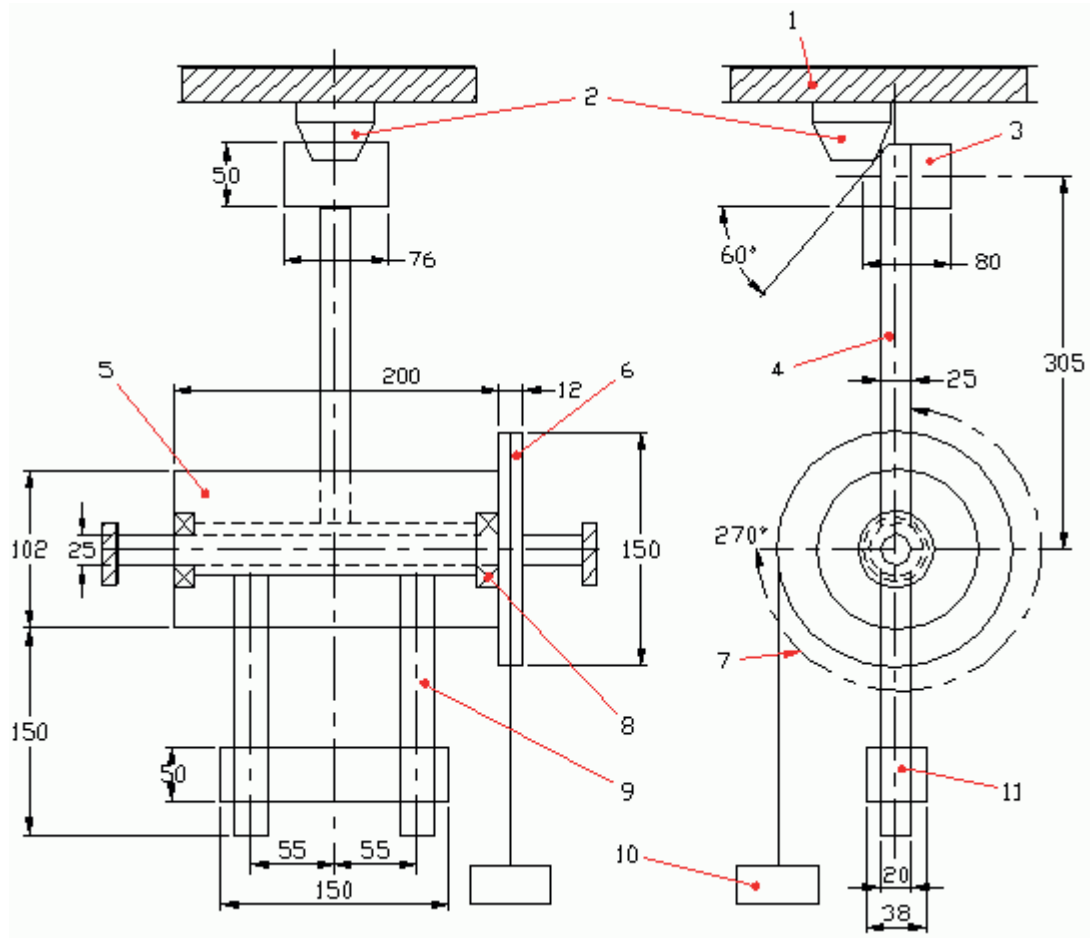

**Key**

- 1 mounting board
- 2 detector
- 3 striker
- 4 striker shaft
- 5 boss
- 6 pulley
- 7 ball bearings
- 8 counter-balance arms
- 9 operating weight
- 10 counter-balance weight

<sup>a</sup> Angle of movement.

NOTE The dimensions shown are for guidance, apart from those relating to the hammer head.

**Figure C.1 — Impact apparatus**

## Annex D (normative)

### Fire test room

**D.1** The specimens to be tested, the measuring ionization chamber (MIC), the temperature probe, the CO monitor, and the measuring part of the obscuration meter shall all be located within the volume shown in [Figures D.1](#) and [D.2](#). Details of the smoke measuring instruments are contained within ISO 7240-7.

**D.2** The specimens, the MIC, the CO monitor, and the mechanical parts of the obscuration meter shall be at least 100 mm apart, measured to the nearest edges. The centreline of the beam of the obscuration meter shall be at least 35 mm below the ceiling.

**D.3** The instrument used for the measurement of CO shall have a measuring accuracy of at least  $1 \mu\text{l/l}$  and better than 5 % of the measured CO concentration. The response time of the instrument shall be such that it does not cause a measurement error at the highest rate of increase that can occur during fires greater than  $5 \mu\text{l/l}$ .

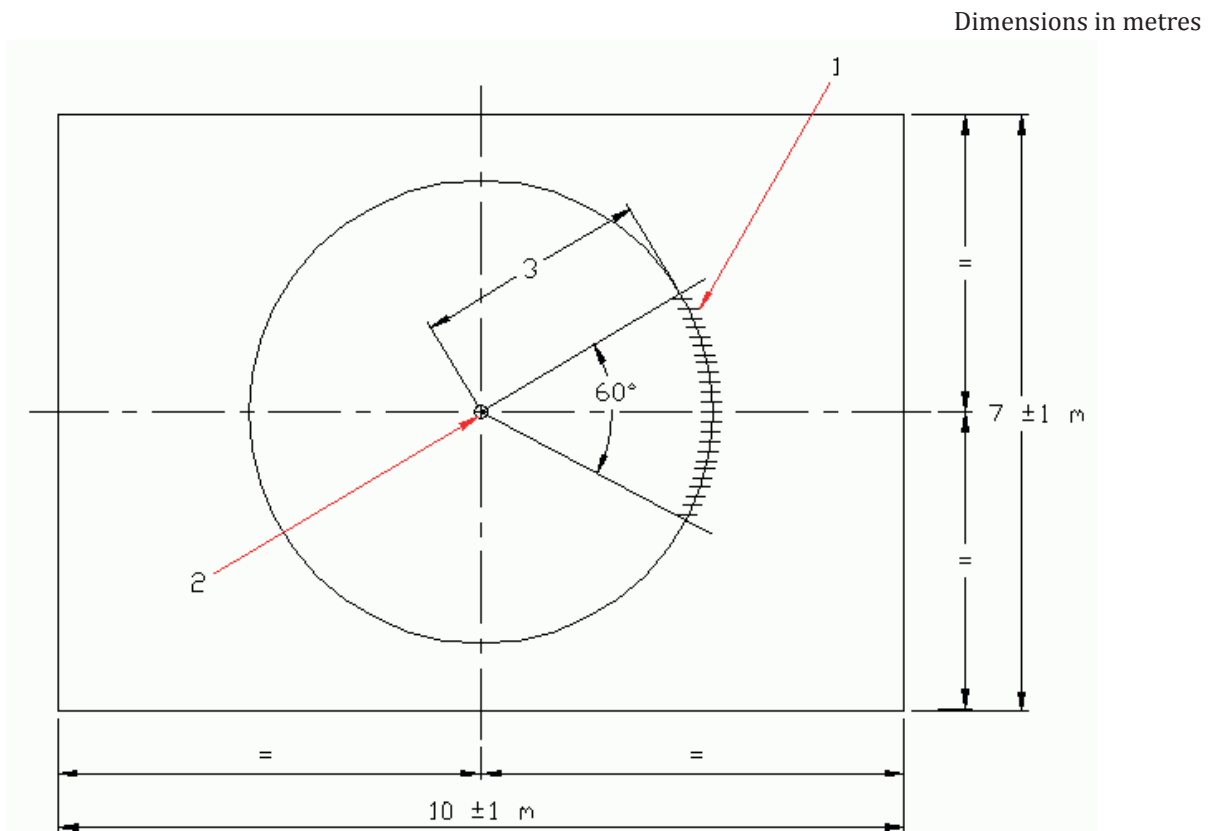

#### Key

- 1 specimens and measuring instruments (see [Figure D.2](#))
- 2 position of test fire

**Figure D.1** — Plan view of fire test room and position of specimens and monitoring instruments

Dimensions in metres

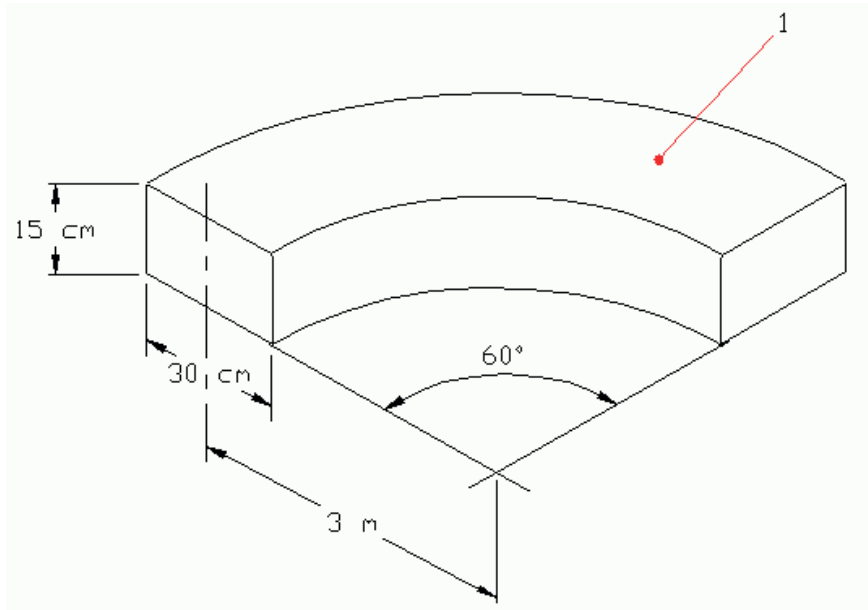

**Key**

1 ceiling

**Figure D.2 — Mounting position for instruments and specimens**



## Annex E (normative)

### Smouldering (pyrolysis) wood fire (TF2)

#### E.1 Fuel

Approximately 10 dried beechwood sticks, each stick having dimensions of 75 mm × 25 mm × 20 mm.

#### E.2 Conditioning

Dry the sticks in a heating oven so the moisture content is approximately 5 %.

#### E.3 Preparation

If necessary, transport the sticks from the oven in a closed plastic bag, and open the bag just prior to laying out the sticks on the test arrangement.

#### E.4 Hotplate

**E.4.1** The hotplate shall have a 220 mm diameter grooved surface with eight concentric grooves with a distance of 3 mm between grooves. Each groove shall be 2 mm deep and 5 mm wide, with the outer groove 4 mm from the edge. The hotplate shall have a rating of approximately 2 kW.

**E.4.2** The temperature of the hot plate shall be measured by a sensor attached to the fifth groove, counted from the edge of the hotplate, and secured to provide a good thermal contact.

#### E.5 Arrangement

The sticks shall be arranged radially on the grooved hotplate surface, with the 20 mm side of the stick in contact with the surface such that the temperature probe lies between the sticks and is not covered, as shown in [Figure E.1](#).

#### E.6 Heating rate

The hotplate shall be powered such that its temperature rises from ambient to 600 °C in approximately 11 min.

#### E.7 Test validity criteria

**E.7.1** No flaming shall occur before the end-of-test condition has been reached. The development of the fire shall be such that the curves of  $m$  against  $y$ , and  $m$  against time,  $t$ , and  $S$  against time,  $t$ , fall within the limits shown in [Figures E.2, E.3](#), and [E.4](#), respectively. That is,  $1,23 < y < 2,05$  and  $570 < t < 840$  at the end-of-test condition  $m_E = 2$  dB/m.

**E.7.2** If the end of test condition  $m_E = 2$  dB/m is reached before all the specimens have responded, then the test is only considered valid if an  $S$  value of 45 µl/l has been achieved.

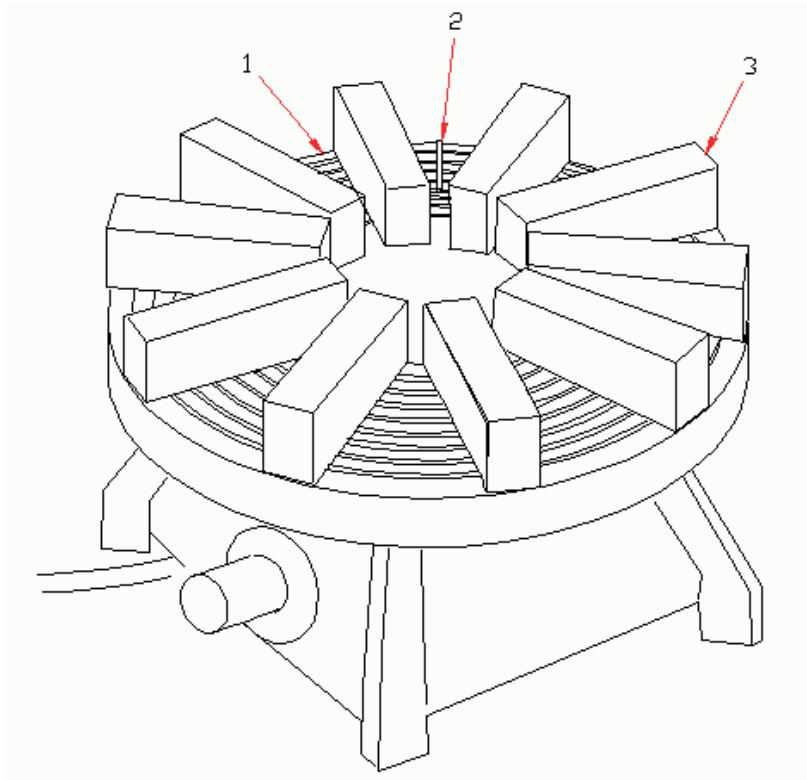

**Key**

- 1 grooved hotplate
- 2 temperature sensor
- 3 wooden sticks

**Figure E.1 — Arrangement of sticks on hotplate**

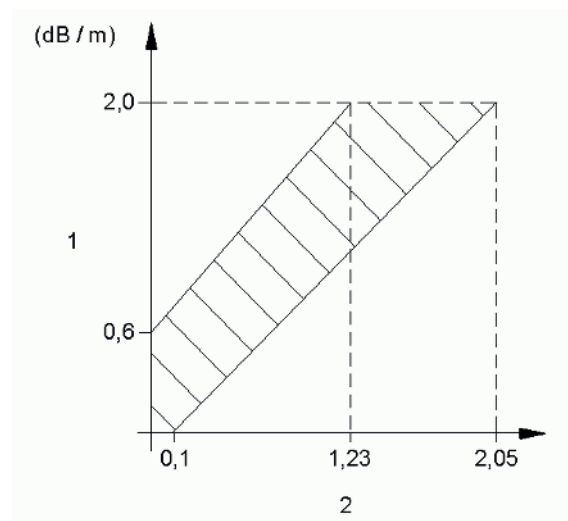

**Key**

- 1 *m*-value
- 2 *y*-value

**Figure E.2 — Limits for *m* against *y*, Fire TF2**

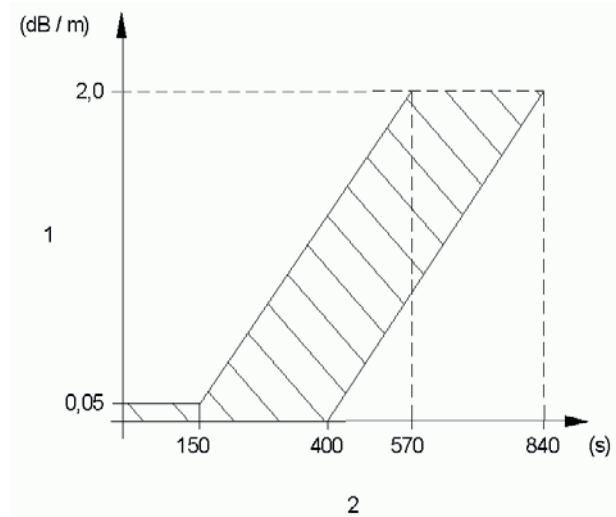

**Key**

- 1 *m*-value
- 2 time, *t*

**Figure E.3 — Limits for *m* against time, *t*, Fire TF2**

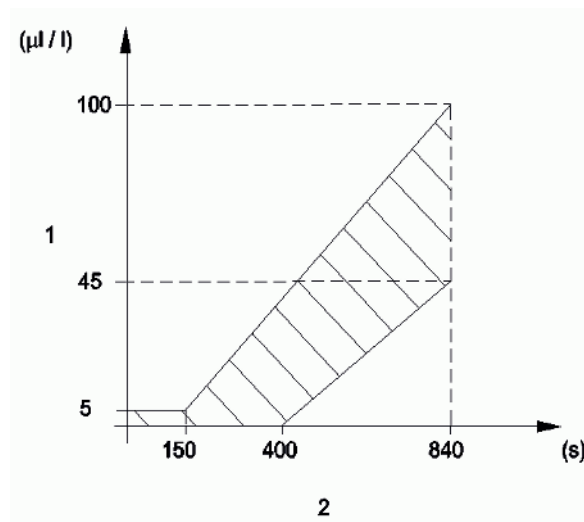

**Key**

- 1 *S*-value
- 2 time, *t*

**Figure E.4 — Limits for *S* against time *t*, Fire TF2**

**E.8 Variables**

The number of sticks, the rate of temperature increase of the hotplate, and the degree of conditioning of the wood may be varied in order for the test fire to remain within the profile curve limits.

## E.9 End-of-test condition

The end-of-test condition shall be when

- $m_E = 2$  dB/m, or
- $t > 840$  s, or
- $S > 100$   $\mu\text{l/l}$ , or
- all of the specimens have generated an alarm signal, whichever is the earlier.

## **Annex F** (normative)

### **Glowing smouldering cotton fire (TF3)**

#### **F.1 Fuel**

Approximately 90 pieces of braided cotton wick, each of length approximately 80 cm and weighing approximately 3 g.

#### **F.2 Conditioning**

Wash and dry the wicks if they have a protective coating. Store the wicks in an environment of no more than 50 % humidity prior to being ignited.

#### **F.3 Arrangement**

The wicks shall be fastened to a ring approximately 10 cm in diameter and suspended approximately 1 m above a non-combustible plate as shown in [Figure F.1](#).

Dimensions in metres

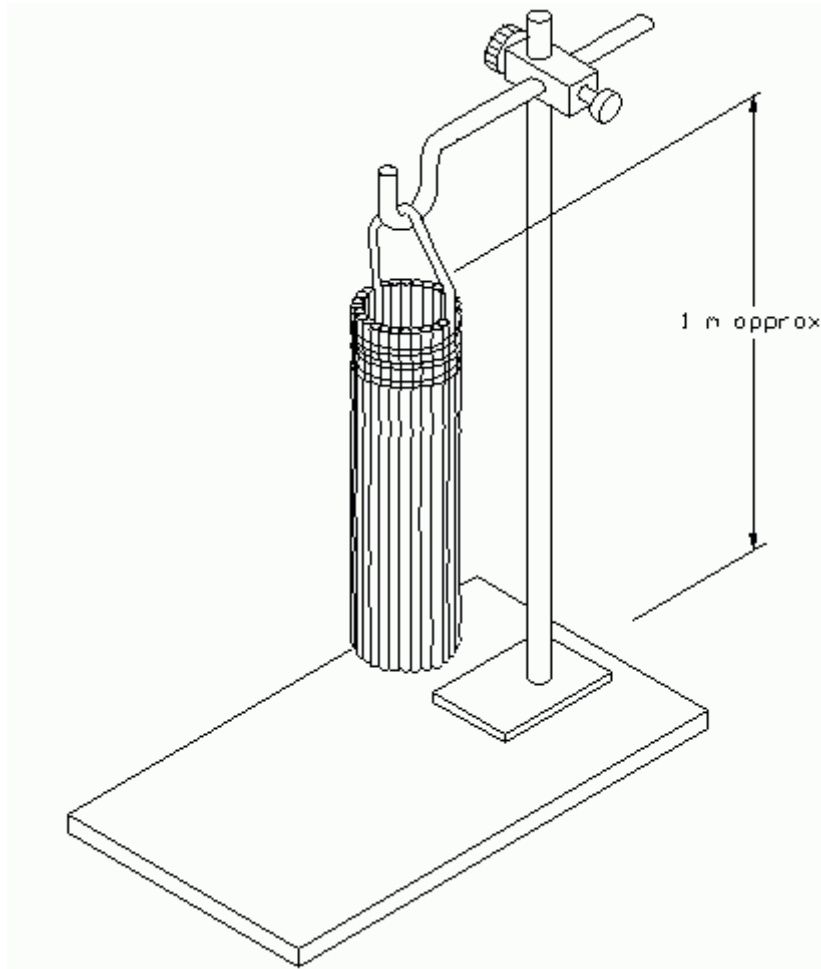

Figure F.1 — Arrangement of cotton wicks

#### F.4 Ignition

The lower end of each wick shall be ignited so that the wicks continue to glow. Any flaming shall be blown out immediately. The test time shall start when all wicks are glowing.

#### F.5 Test validity criteria

**F.5.1** The development of the fire shall be such that the curves of  $m$  against  $y$ ,  $m$  against time,  $t$ , and  $S$  against time,  $t$ , fall within limits shown in [Figures F.2, F.3, and F.4](#), respectively. That is  $3,2 < y < 5,33$  and  $280 < t < 750$  at the end-of-test condition  $m_E = 2$  dB/m.

**F.5.2** If the end-of-test condition  $m_E = 2$  dB/m is reached before all the specimens have responded, then the test is only considered valid if an  $S$  value of  $150 \mu\text{l/l}$  has been achieved.

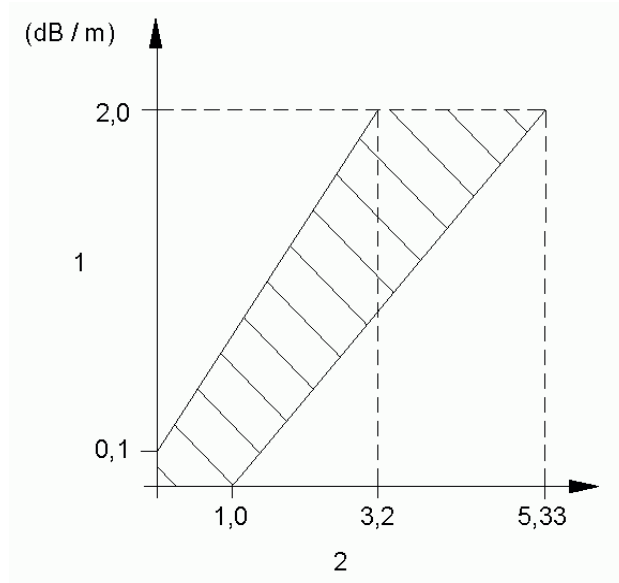

**Key**

- 1  $m$ -value
- 2  $y$ -value

**Figure F.2 — Limits for  $m$  against  $y$ , Fire TF3**

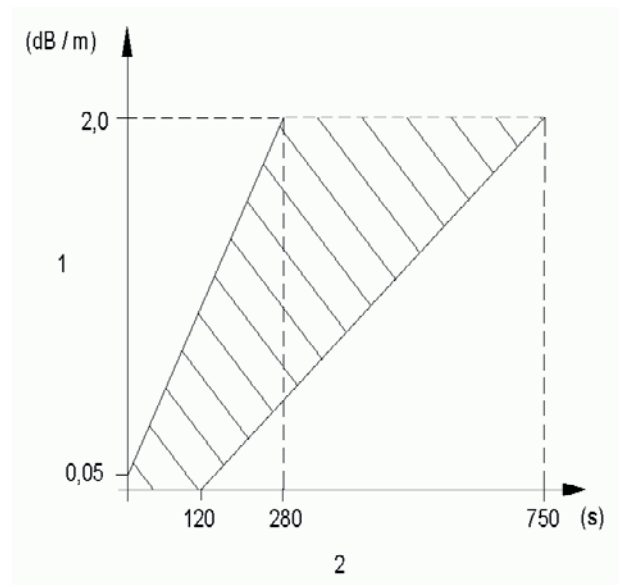

**Key**

- 1  $m$ -value
- 2 time,  $t$

**Figure F.3 — Limits for  $m$  against time,  $t$ , Fire TF3**

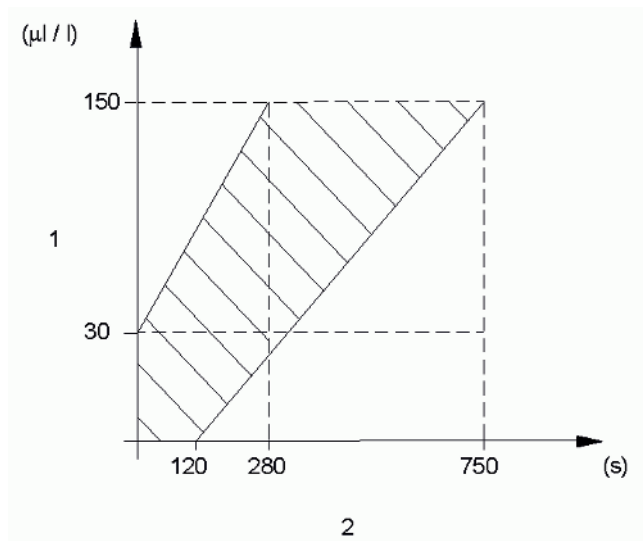

**Key**

- 1 S-value
- 2 time,  $t$

**Figure F.4 — Limits for  $S$  against time,  $t$ , Fire TF3**

### F.6 End-of-test condition

The end-of-test condition shall be when

- $m_E = 2$  dB/m, or
- $t > 750$  s, or
- $S > 150$  µl/l, or
- all of the specimens have generated an alarm signal, whichever is the earlier.



## Annex G (normative)

### Open plastics (polyurethane) fire (TF4)

#### G.1 Fuel

Three mats, approximately 50 cm × 50 cm × 2 cm, of soft polyurethane foam, without flame-retardant additives and having a density of approximately 20 kg/m<sup>3</sup>, are usually found sufficient. However, the exact quantity of fuel may be adjusted to obtain valid tests.

#### G.2 Conditioning

Maintain the mats in a humidity not exceeding 50 % at least 48 h prior to test.

#### G.3 Arrangement

Place the mats one on top of another on a base formed from aluminium foil with the edges folded up to provide a tray.

#### G.4 Ignition

Ignite by match or spark. Ignite the mats at a corner of the lower mat. Adjust the exact position of ignition to obtain a valid test. A small quantity of a clean burning material (e.g. 5 cm<sup>3</sup> of methylated spirit) may be used to assist the ignition.

#### G.5 Test validity criteria

**G.5.1** The development of the fire shall be such that the curves of  $m$  against  $y$ ,  $m$  against time,  $t$ , and  $S$  against time,  $t$ , fall within limits shown in [Figures G.1](#), [G.2](#), and [G.3](#), respectively. That is  $1,27 < m < 1,73$  and  $140 \text{ s} < t < 180 \text{ s}$  at the end-of-test condition  $y_E = 6$ .

**G.5.2** If the end of test condition,  $y_E = 6$  is reached before all the specimens have responded, then the test is only considered valid if an  $S$  value of 20 µl/l and a temperature rise of 8 K has been achieved.

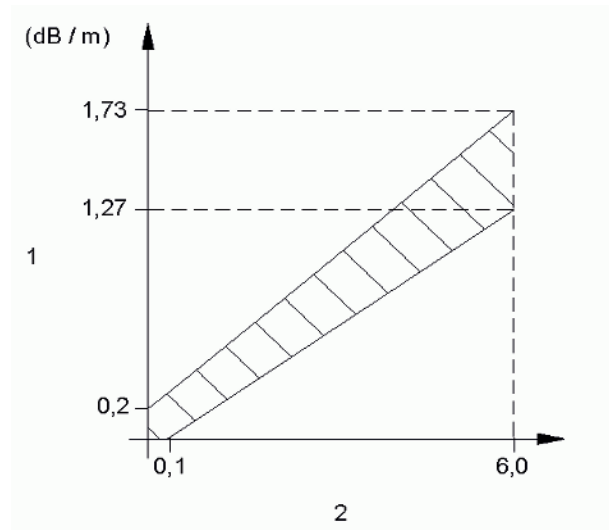

**Key**  
 1 *m*-value  
 2 *y*-value

**Figure G.1 — Limits for *m* against *y*, Fire TF4**

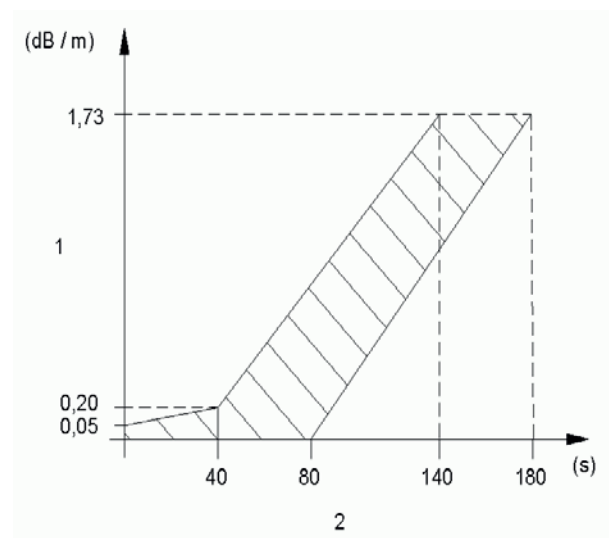

**Key**  
 1 *m*-value  
 2 time, *t*

**Figure G.2 — Limits for *m* against time, *t*, Fire TF4**

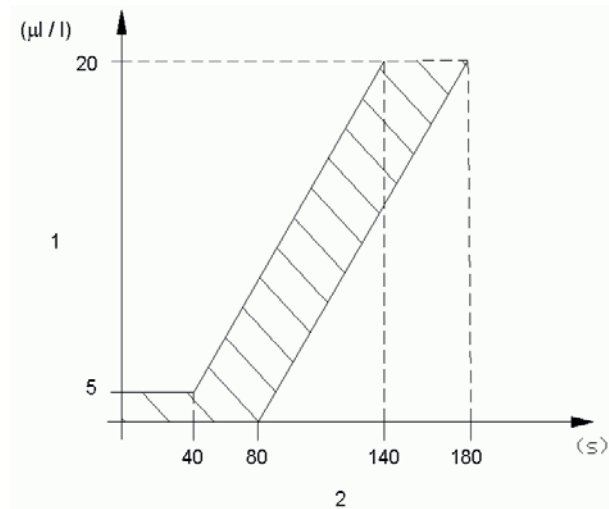

**Key**

- 1 S-value
- 2 time,  $t$

**Figure G.3 — Limits for  $S$  against time,  $t$ , Fire TF4**

## G.6 End-of-test condition

The end-of-test condition shall be when

- $y_E = 6$ , or
- $t > 180$  s, or
- $S > 20 \mu\text{l/l}$ , or
- all of the specimens have generated an alarm signal, whichever is the earlier.



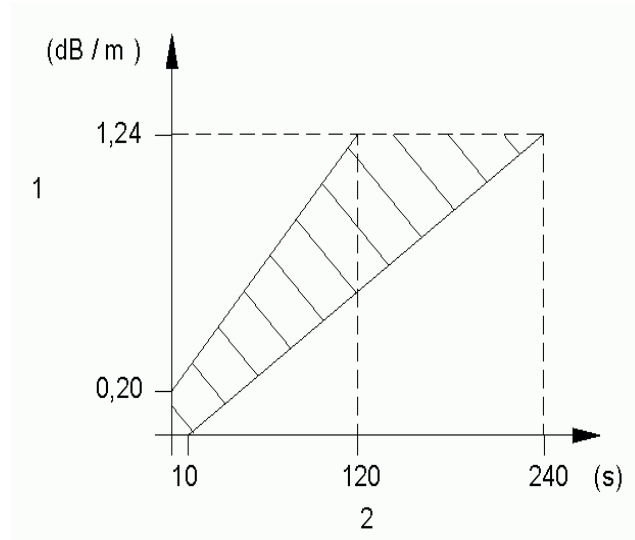

**Key**

- 1 *m*-value
- 2 time, *t*

**Figure H.2 — Limits for *m* against time, *t*, Fire TF5**

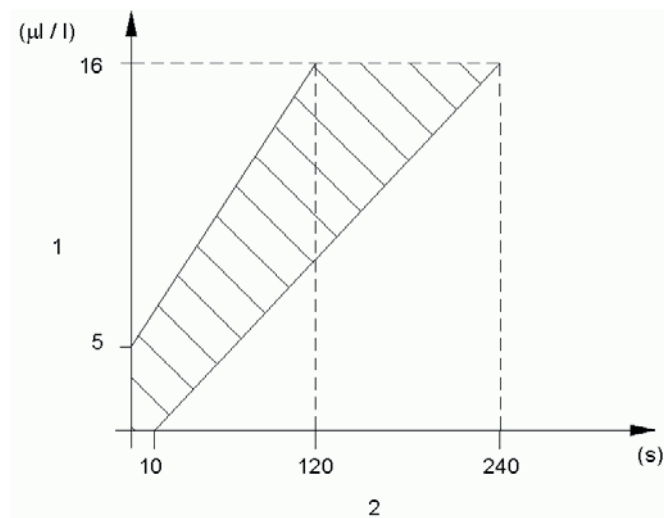

**Key**

- 1 *S*-value
- 2 time, *t*

**Figure H.3 — Limits for *S* against time, *t*, Fire TF5**

## H.5 End-of-test condition

The end-of-test condition shall be when

- $y_E = 6$ , or
- $t > 240$  s, or
- $S > 16$   $\mu\text{l/l}$ , or
- all of the specimens have generated an alarm signal, whichever is the earlier.

## Annex I (informative)

### Information concerning the construction of the gas test chamber

- I.1** Fire detectors respond when the signal(s) from one or more fire sensors fulfil certain criteria. The gas concentration at the sensor(s) is related to the gas concentration surrounding the detector but the relation is usually complex and dependent on several factors, such as orientation, mounting, air velocity, turbulence, rate of rise of gas concentration, etc. The relative change of the response threshold value measured in the gas test chamber is the main parameter considered when the stability of fire detectors is evaluated by testing in accordance with this part of ISO 7240.
- I.2** Many different gas test chamber designs are suitable for the tests specified in this part of ISO 7240 but the following points should be considered when designing and characterizing a gas test chamber.
- I.3** The larger the gas test chamber, the larger the volume of gas required during tests. Environmental control, personal safety and uniform gas distribution will be more easily achieved if the volume of the gas test chamber is kept to a minimum. The control of test gases that may escape the chamber is also important. The chamber should be as gas-tight as possible.
- I.4** The CO response value measurements require increasing gas concentration until the detector responds. This may be facilitated in a closed-circuit gas test chamber. A purging system is required to purge the gas test chamber after each gas exposure. Some means to maintain the pressure inside the chamber close to atmospheric may be required to prevent pressure variations caused by the introduction of CO or other test gas.
- I.5** The airflow created by a fan in the chamber will be turbulent, and needs to pass through a turbulence reducer to create a nearly laminar and uniform airflow in the working volume (see [Figure I.1](#)). This may be facilitated by using a filter, honeycomb, or both, in line with and upstream of the working section of the tunnel. Care should be taken to ensure that the airflow is well mixed to give a uniform temperature and gas concentration before entering the flow turbulence reducer. Efficient mixing can be obtained by feeding the gas to the tunnel upstream of the fan.
- I.6** Means for heating the air before it enters the working section are required. The chamber should have a system capable of controlling the heating as to achieve the specified temperatures and temperature profiles in the working volume. The heating should be achieved by means of low-temperature heaters to avoid the production of extraneous gases or alteration of the test gas.
- I.7** Special attention should be given to the arrangement of the elements in the working volume in order to avoid disturbance of the test conditions, e.g. due to turbulence. Where gas sensing is done by air sampling, the suction through the gas sensors creates a mean air velocity of approximately 0,04 m/s in the plane of the entrance openings in the chamber housing. However, the effect of the suction will be negligible if the gas, the sampling inlet of the gas sensor should preferably be placed 10 cm to 15 cm downstream of the detector position.

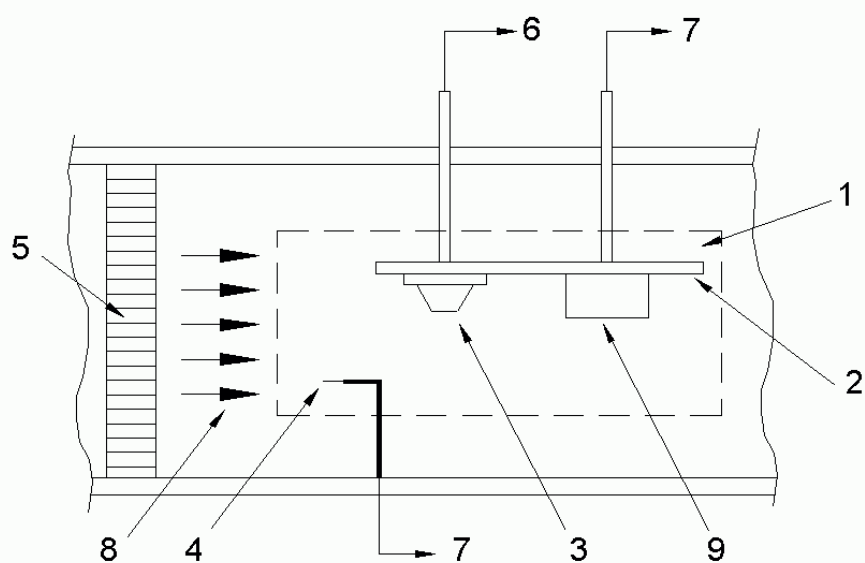

**Key**

- 1 working volume
- 2 mounting board
- 3 detector(s) under test
- 4 temperature sensor
- 5 turbulence reducer
- 6 supply and monitoring equipment
- 7 control and measuring equipment
- 8 airflow
- 9 gas sensor

**Figure I.1 — Gas test chamber, working section, side view**



## Annex J (informative)

### Construction of the heat tunnel

**J.1** Heat detectors respond when the signal(s) from one or more sensors fulfil(s) certain criteria. The temperature of the sensor(s) is related to the air temperature surrounding the detector, but the relation is usually complex and dependent on several factors, such as orientation, mounting, air velocity, turbulence, rate of rise of air temperature, etc. Response times and response temperature and their stability are the main parameters considered when the fire-detection performance of heat detectors is evaluated by testing in accordance with this part of ISO 7240

**J.2** Many different heat-tunnel designs are suitable for the tests specified in this part of ISO 7240 but the following points should be considered when designing and characterizing a heat tunnel.

**J.3** There are two basic types of heat tunnels; recirculating and non-recirculating. All else being equal, a non-recirculating tunnel requires a higher-powered heater than a recirculating tunnel, particularly for the higher rates of rise of air temperature. More care is generally needed to ensure that the high-powered heater and control system of a non-recirculating tunnel are sufficiently responsive to the changes in heat demand necessary to attain the required temperature-versus-time conditions in the working section. On the other hand, maintaining a constant mass flow with increasing temperature is generally more difficult in a recirculating tunnel.

**J.4** The temperature control system shall be able to maintain the temperature within  $\pm 2$  K of the “ideal ramp” for all of the specified rates of rise of air temperature. Such performance can be achieved in different ways e.g.:

- by proportional heating control, where more heating elements are used when generating higher rates of rise. Improved temperature control may be achieved by powering some of the heating elements continuously, while controlling others. With this control system the distance between the tunnel heater and the detector under test should not be so large that the intrinsic delay in the temperature-control feedback loop becomes excessive at an air flow of  $(0,8 \pm 0,1)$  m/s;
- by rate-controlled feed-forward heating control, assisted by proportional/integral (PI) feedback. This control system will permit greater distance between the tunnel heater and the detector under test.

**J.5** The important point is that the specified temperature profiles are obtained with the required accuracy within the working section.

**J.6** For a non-recirculating tunnel, the anemometer used for air flow control and monitoring may be placed in a section of the tunnel upstream of the heater, where it will be subject to a substantially constant temperature, thereby eliminating any need to temperature compensate its output. A constant velocity, indicated by an anemometer so positioned, should correlate with a constant mass flow through the working volume. However, to maintain a constant mass flow at normal atmospheric pressure in a recirculating tunnel, it is necessary to increase the air velocity as the air temperature is increased. Careful consideration should therefore be given to ensuring that there is an appropriate correction for the temperature coefficient of the anemometer monitoring the airflow. It should not be assumed that an automatically temperature-compensated anemometer would compensate sufficiently quickly at high rates of rise of air temperature.

**J.7** The air flow created by a fan in the tunnel will be turbulent, and will need to pass through a turbulence reducer to create a nearly laminar and uniform air flow in the working volume (see [Figure J.1](#)).

This can be facilitated by using a filter, honeycomb or both, in line with, and upstream of, the working section of the tunnel. Care should be taken to ensure that the airflow from the heater is mixed to a uniform temperature before entering the turbulence reducer.

**J.8** It is not possible to design a tunnel where uniform temperature and flow conditions prevail in all parts of the working section. Deviations will exist, especially close to the walls of the tunnel where a boundary layer of slower and cooler air will normally be observed. The thickness of this boundary layer and the temperature gradient across it can be reduced by constructing or lining the walls of the tunnel with a low-thermal conductivity material.

**J.9** Special attention shall be given to the temperature-measuring system in the tunnel. The required overall time constant of not greater than 2 s in air means that the temperature sensor should have a very small thermal mass. In practice, only the fastest thermocouples and similar small sensors will be adequate for the measuring system. The effect of heat loss from the sensor via its leads can normally be minimized by exposing several centimeters of the lead to the airflow.

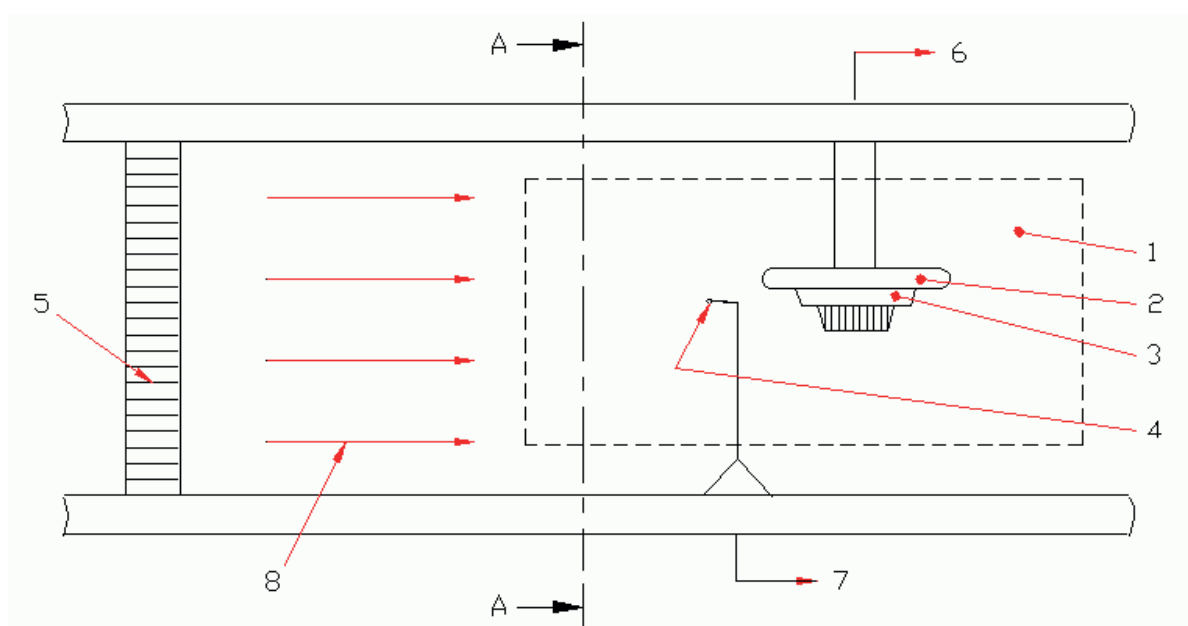

**Key**

- 1 working volume
- 2 mounting board
- 3 detector(s) under test
- 4 temperature sensor
- 5 turbulence reducer
- 6 output to supply and monitoring equipment
- 7 output control and measuring equipment
- 8 air flow

**Figure J.1 — Example of working section of heat tunnel**

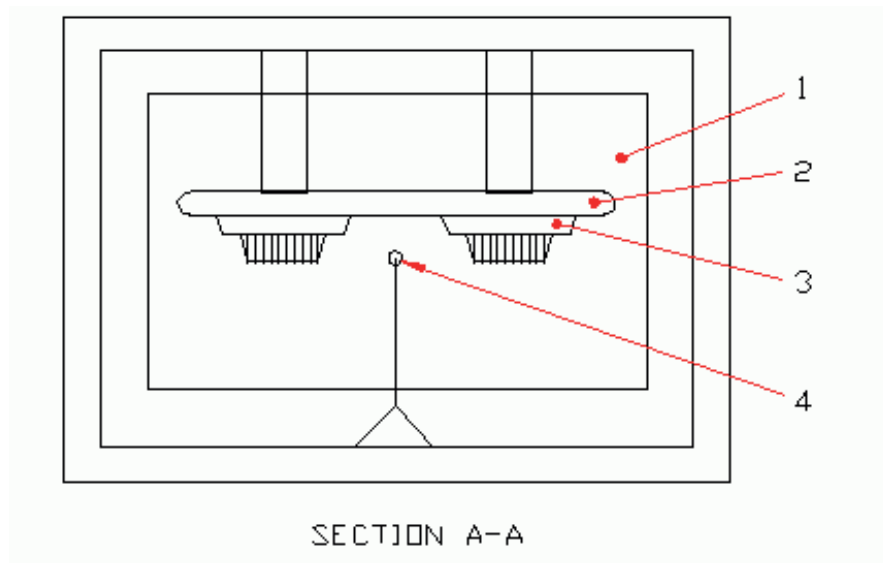

**Key**

- 1 working volume
- 2 mounting boards
- 3 detectors under tests
- 4 temperature sensor

**Figure J.2 — Example of mounting arrangement for simultaneously testing two detectors**





# British Standards Institution (BSI)

BSI is the national body responsible for preparing British Standards and other standards-related publications, information and services.

BSI is incorporated by Royal Charter. British Standards and other standardization products are published by BSI Standards Limited.

## About us

We bring together business, industry, government, consumers, innovators and others to shape their combined experience and expertise into standards-based solutions.

The knowledge embodied in our standards has been carefully assembled in a dependable format and refined through our open consultation process. Organizations of all sizes and across all sectors choose standards to help them achieve their goals.

## Information on standards

We can provide you with the knowledge that your organization needs to succeed. Find out more about British Standards by visiting our website at [bsigroup.com/standards](http://bsigroup.com/standards) or contacting our Customer Services team or Knowledge Centre.

## Buying standards

You can buy and download PDF versions of BSI publications, including British and adopted European and international standards, through our website at [bsigroup.com/shop](http://bsigroup.com/shop), where hard copies can also be purchased.

If you need international and foreign standards from other Standards Development Organizations, hard copies can be ordered from our Customer Services team.

## Subscriptions

Our range of subscription services are designed to make using standards easier for you. For further information on our subscription products go to [bsigroup.com/subscriptions](http://bsigroup.com/subscriptions).

With **British Standards Online (BSOL)** you'll have instant access to over 55,000 British and adopted European and international standards from your desktop. It's available 24/7 and is refreshed daily so you'll always be up to date.

You can keep in touch with standards developments and receive substantial discounts on the purchase price of standards, both in single copy and subscription format, by becoming a **BSI Subscribing Member**.

**PLUS** is an updating service exclusive to BSI Subscribing Members. You will automatically receive the latest hard copy of your standards when they're revised or replaced.

To find out more about becoming a BSI Subscribing Member and the benefits of membership, please visit [bsigroup.com/shop](http://bsigroup.com/shop).

With a **Multi-User Network Licence (MUNL)** you are able to host standards publications on your intranet. Licences can cover as few or as many users as you wish. With updates supplied as soon as they're available, you can be sure your documentation is current. For further information, email [bsmusales@bsigroup.com](mailto:bsmusales@bsigroup.com).

## BSI Group Headquarters

389 Chiswick High Road London W4 4AL UK

## Revisions

Our British Standards and other publications are updated by amendment or revision.

We continually improve the quality of our products and services to benefit your business. If you find an inaccuracy or ambiguity within a British Standard or other BSI publication please inform the Knowledge Centre.

## Copyright

All the data, software and documentation set out in all British Standards and other BSI publications are the property of and copyrighted by BSI, or some person or entity that owns copyright in the information used (such as the international standardization bodies) and has formally licensed such information to BSI for commercial publication and use. Except as permitted under the Copyright, Designs and Patents Act 1988 no extract may be reproduced, stored in a retrieval system or transmitted in any form or by any means – electronic, photocopying, recording or otherwise – without prior written permission from BSI. Details and advice can be obtained from the Copyright & Licensing Department.

## Useful Contacts:

### Customer Services

**Tel:** +44 845 086 9001

**Email (orders):** [orders@bsigroup.com](mailto:orders@bsigroup.com)

**Email (enquiries):** [cservices@bsigroup.com](mailto:cservices@bsigroup.com)

### Subscriptions

**Tel:** +44 845 086 9001

**Email:** [subscriptions@bsigroup.com](mailto:subscriptions@bsigroup.com)

### Knowledge Centre

**Tel:** +44 20 8996 7004

**Email:** [knowledgecentre@bsigroup.com](mailto:knowledgecentre@bsigroup.com)

### Copyright & Licensing

**Tel:** +44 20 8996 7070

**Email:** [copyright@bsigroup.com](mailto:copyright@bsigroup.com)



...making excellence a habit.™