

BS ISO 7131:2009



BSI Standards Publication

Earth-moving machinery — Loaders — Terminology and commercial specifications

bsi.

...making excellence a habit.™

National foreword

This British Standard is the UK implementation of ISO 7131:2009. It supersedes BS 6914-10:1998 which is withdrawn.

The UK participation in its preparation was entrusted to Technical Committee B/513/1, Earth moving machinery (International).

A list of organizations represented on this committee can be obtained on request to its secretary.

This publication does not purport to include all the necessary provisions of a contract. Users are responsible for its correct application.

© BSI 2011

ISBN 978 0 580 60352 5

ICS 01.040.53; 53.100

Compliance with a British Standard cannot confer immunity from legal obligations.

This British Standard was published under the authority of the Standards Policy and Strategy Committee on 31 August 2011.

Amendments issued since publication

Date	Text affected
------	---------------

INTERNATIONAL STANDARD

BS ISO 7131:2009

ISO
7131

Third edition
2009-10-15

Earth-moving machinery — Loaders — Terminology and commercial specifications

*Engins de terrassement — Chargeuses — Terminologie et
spécifications commerciales*



Reference number
ISO 7131:2009(E)

© ISO 2009

PDF disclaimer

This PDF file may contain embedded typefaces. In accordance with Adobe's licensing policy, this file may be printed or viewed but shall not be edited unless the typefaces which are embedded are licensed to and installed on the computer performing the editing. In downloading this file, parties accept therein the responsibility of not infringing Adobe's licensing policy. The ISO Central Secretariat accepts no liability in this area.

Adobe is a trademark of Adobe Systems Incorporated.

Details of the software products used to create this PDF file can be found in the General Info relative to the file; the PDF-creation parameters were optimized for printing. Every care has been taken to ensure that the file is suitable for use by ISO member bodies. In the unlikely event that a problem relating to it is found, please inform the Central Secretariat at the address given below.



COPYRIGHT PROTECTED DOCUMENT

© ISO 2009

All rights reserved. Unless otherwise specified, no part of this publication may be reproduced or utilized in any form or by any means, electronic or mechanical, including photocopying and microfilm, without permission in writing from either ISO at the address below or ISO's member body in the country of the requester.

ISO copyright office
Case postale 56 • CH-1211 Geneva 20
Tel. + 41 22 749 01 11
Fax + 41 22 749 09 47
E-mail copyright@iso.org
Web www.iso.org

Published in Switzerland

Contents

Page

Foreword	iv
1 Scope	1
2 Normative references	1
3 Terms and definitions	2
4 Base machine	4
5 Equipment and attachments	10
6 Performance terminology	14
7 Commercial literature specifications	15
Annex A (normative) Loader equipment and attachments — Dimensions	20
Bibliography	27

Foreword

ISO (the International Organization for Standardization) is a worldwide federation of national standards bodies (ISO member bodies). The work of preparing International Standards is normally carried out through ISO technical committees. Each member body interested in a subject for which a technical committee has been established has the right to be represented on that committee. International organizations, governmental and non-governmental, in liaison with ISO, also take part in the work. ISO collaborates closely with the International Electrotechnical Commission (IEC) on all matters of electrotechnical standardization.

International Standards are drafted in accordance with the rules given in the ISO/IEC Directives, Part 2.

The main task of technical committees is to prepare International Standards. Draft International Standards adopted by the technical committees are circulated to the member bodies for voting. Publication as an International Standard requires approval by at least 75 % of the member bodies casting a vote.

Attention is drawn to the possibility that some of the elements of this document may be the subject of patent rights. ISO shall not be held responsible for identifying any or all such patent rights.

ISO 7131 was prepared by Technical Committee ISO/TC 127, *Earth-moving machinery*, Subcommittee SC 4, *Terminology, commercial nomenclature, classification and rating*.

This third edition cancels and replaces the second edition (ISO 7131:1997), which has been technically revised.

Earth-moving machinery — Loaders — Terminology and commercial specifications

1 Scope

This International Standard establishes the terminology and content of commercial literature specifications for self-propelled crawler and wheeled loaders as defined in ISO 6165, with their equipment and attachments, used in earth-moving operations.

2 Normative references

The following referenced documents are indispensable for the application of this document. For dated references, only the edition cited applies. For undated references, the latest edition of the referenced document (including any amendments) applies.

ISO 3450, *Earth-moving machinery — Braking systems of rubber-tyred machines — Systems and performance requirements and test procedures*

ISO 6014, *Earth-moving machinery — Determination of ground speed*

ISO 6016:2008, *Earth-moving machinery — Methods of measuring the masses of whole machines, their equipment and components*

ISO 6165:2006, *Earth-moving machinery — Basic types — Identification and terms and definitions*

ISO 6746:2003 (all parts), *Earth-moving machinery — Definitions of dimensions and codes*

ISO 7457, *Earth-moving machinery — Measurement of turning dimensions of wheeled machines*

ISO 9249, *Earth-moving machinery — Engine test code — Net power*

ISO 10265, *Earth-moving machinery — Crawler machines — Performance requirements and test procedures for braking systems*

ISO 14396, *Reciprocating internal combustion engines — Determination and method for the measurement of engine power — Additional requirements for exhaust emission tests in accordance with ISO 8178*

ISO 14397-1, *Earth-moving machinery — Loaders and backhoe loaders — Part 1: Calculation of rated operating capacity and test method for verifying calculated tipping load*

ISO 14397-2, *Earth-moving machinery — Loaders and backhoe loaders — Part 2: Test method for measuring breakout forces and lift capacity to maximum lift height*

3 Terms and definitions

For the purposes of this document, the terms and definitions given in ISO 6165, ISO 6746 and the following apply.

3.1 General

3.1.1 loader

self-propelled crawler or wheeled machine which has front-mounted equipment primarily designed for loading operation (bucket use) and which loads or excavates through forward motion of the machine

NOTE A loader work cycle normally comprises filling, elevating, transporting and discharging of material.

[ISO 6165:2006, definition 4.2]

3.1.1.1

compact loader

loader (3.1.1) having an **operating mass** (3.2.1) of 4 500 kg or less, designed to work in confined spaces with the associated need for greater manoeuvrability

NOTE The general term *compact machine* is defined in ISO 6165.

3.1.1.2

skid steer loader

loader (3.1.1) which normally has an operator station between attachment-supporting structures and which is steered by using variation of speed, and/or direction of rotation between traction drives on the opposite sides of a machine having fixed axles on wheels or tracks

[ISO 6165:2006, definition 4.2.2]

3.1.2

base machine

machine with a cab or canopy and operator-protective structures if required, without equipment or attachments but possessing the necessary mountings for such equipment and attachments

[ISO 6746-1:2003, definition 3.3]

NOTE The machine will need to be provided with the necessary mountings to secure equipment and attachments (see Clause 5).

3.2 Masses

3.2.1

operating mass

OM

mass of the **base machine** (3.1.2), with equipment and empty **attachment** (3.3.1) in the most usual configuration as specified by the manufacturer, and with the operator (75 kg), full fuel tank and all fluid systems (i.e. hydraulic oil, transmission oil, engine oil, engine coolant) at the levels specified by the manufacturer and, when applicable, with sprinkler water tank(s) half full

NOTE 1 The mass of an operator is not included for non-riding machines.

NOTE 2 Ballast mass at delivery can be included if specified by the manufacturer.

[ISO 6016:2008, definition 3.2.1]

3.2.2 shipping mass SM

mass of the base machine without an operator, and with fuel level at 10 % of tank capacity or with the minimum fuel level needed for machine shipping purposes as specified by the manufacturer, whichever is higher, with all fluid systems at the levels specified by the manufacturer, and with empty sprinkler tank(s), if required, and with or without equipment, ballast, attachment, cab, canopy, operator-protective structures, wheels and counterweights as stated by the manufacturer

NOTE If the manufacturer intends that the machine be partially disassembled for shipping purposes, the masses of the disassembled items will also be stated.

[ISO 6016:2008, definition 3.2.6]

3.3 Attachments

3.3.1 attachment

assembly of components that can be mounted onto the **base machine** (3.1.2) or equipment for specific use

[ISO 6746-2:2003, definition 3.5]

3.3.1.1 backhoe

attachment (3.3.1) which generally excavates towards the machine and below ground level, and which elevates, swings and dumps material by the action of a boom, arm and bucket

NOTE For dedicated backhoe loaders, see ISO 8812.

3.3.1.2 scarifier

attachment (3.3.1) having teeth for penetrating and loosening to shallow depths materials such as earth, asphalt and gravel for roads and for similar functions

See Figure 19.

NOTE It is usually mounted on the back of the loader but can be mounted on the back of the bucket.

3.3.2 side dump bucket

bucket which loads through forward motion of the machine and which can dump to the side from an end, or dump forwards

See Figure 17.

3.3.3 multi-purpose bucket

bucket having a dozer-type mouldboard with hinges at the top to support a clam which can be opened to various positions, providing for use as a dozer, scraper, clam or bucket

See Figure 17.

3.3.4

fork arm

structure having tines for lifting, transporting and discharging warehouse-type pallets

See Figure 22.

NOTE When the fork attachment is fitted to a loader, the machine is still classified as an earth-moving machine, not a rough terrain fork truck.

3.3.5

log fork

log grapple

mechanism having tines and a top clamp for lifting, transporting, and discharging logs

See Figure 23.

3.3.6

winch

frame equipped with a drum and connected to the rear part of the **base machine** (3.1.2)

See Figure 24.

3.4

equipment

set of components mounted onto the base of the machine to provide the primary design function of the loader

4 Base machine

4.1 Types of loader

Loaders shall be classified by type of attribute: according to their undercarriage, engine location, and steering and drive systems.

4.1.1 Undercarriage

4.1.1.1 Crawler loader (see Figure 1)

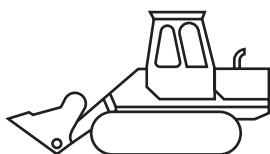

Figure 1 — Crawler loader

4.1.1.2 Wheeled loader (see Figure 2)



Figure 2 — Wheeled loader

4.1.2 Engine location

4.1.2.1 Front engine (see Figure 3)



Figure 3 — Front engine

4.1.2.2 Rear engine (see Figure 4)



Figure 4 — Rear engine

4.1.3 Steering system

4.1.3.1 Front-wheel steer (see Figure 5)

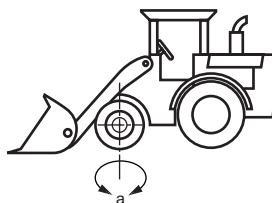

^a Steerable wheels.

Figure 5 — Front-wheel steer

4.1.3.2 Rear-wheel steer (see Figure 6)

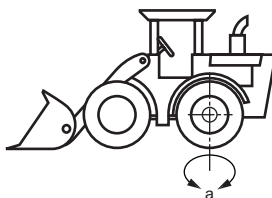

^a Steerable wheels.

Figure 6 — Rear-wheel steer

4.1.3.3 All-wheel steer (see Figure 7)

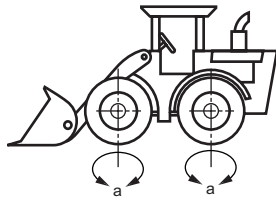

^a Steerable wheels.

Figure 7 — All-wheel steer

4.1.3.4 Articulated steer (see Figure 8)

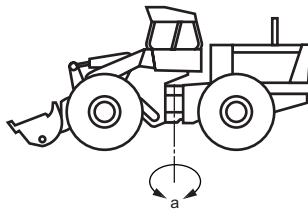

^a Turning centre.

Figure 8 — Articulated steer

4.1.3.5 Wheel-skid steer (see Figure 9)



Key

v wheel velocity ($v_1 \neq v_2$)

^a Turning centre.

Figure 9 — Wheel skid steer

4.1.3.6 Crawler pivot steer (see Figure 10)

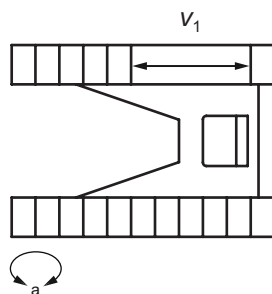

Key

- v_1 track velocity
- a Steerable pivot.

Figure 10 — Crawler pivot steer

4.1.3.7 Crawler independent steer or crawler skid steer (see Figure 11)

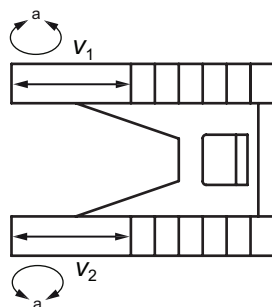

Key

- v track velocity ($v_1 \neq v_2$)
- a Steerable track.

Figure 11 — Crawler independent steer or crawler skid steer

4.1.4 Drive system

4.1.4.1 Front-wheel drive (see Figure 12)

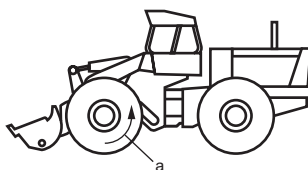

- a Drive wheels.

Figure 12 — Front-wheel drive

4.1.4.2 **Rear-wheel drive** (see Figure 13)

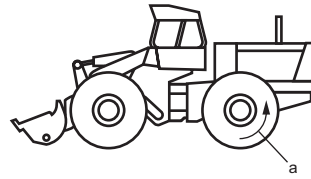

^a Drive wheels.

Figure 13 — Rear-wheel drive

4.1.4.3 **All-wheel drive** (see Figure 14)

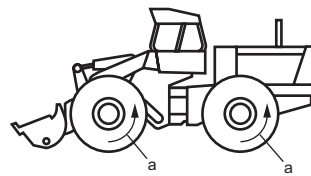

^a Drive wheels.

Figure 14 — All-wheel drive

4.2 Dimensions

Figure 15 shows the base machine dimensions on a crawler loader.

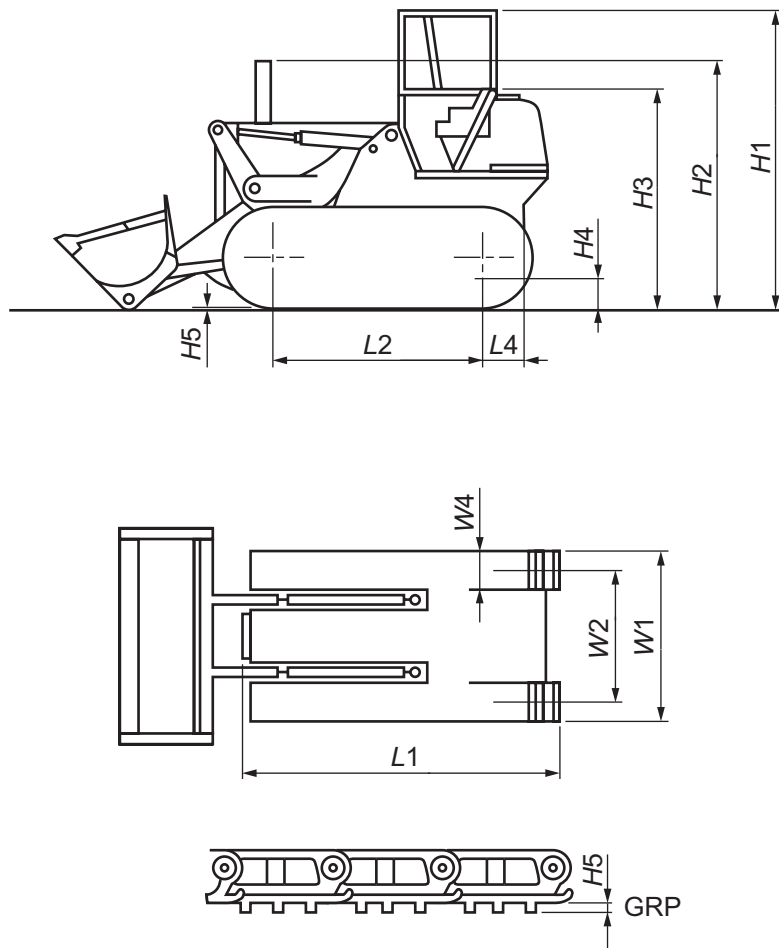

Key

GRP ground reference plane

For the definition of the dimensions, see ISO 6746-1.

Figure 15 — Base machine dimensions (crawler loader)

5 Equipment and attachments

5.1 Nomenclature

See Figures 16 and 17.

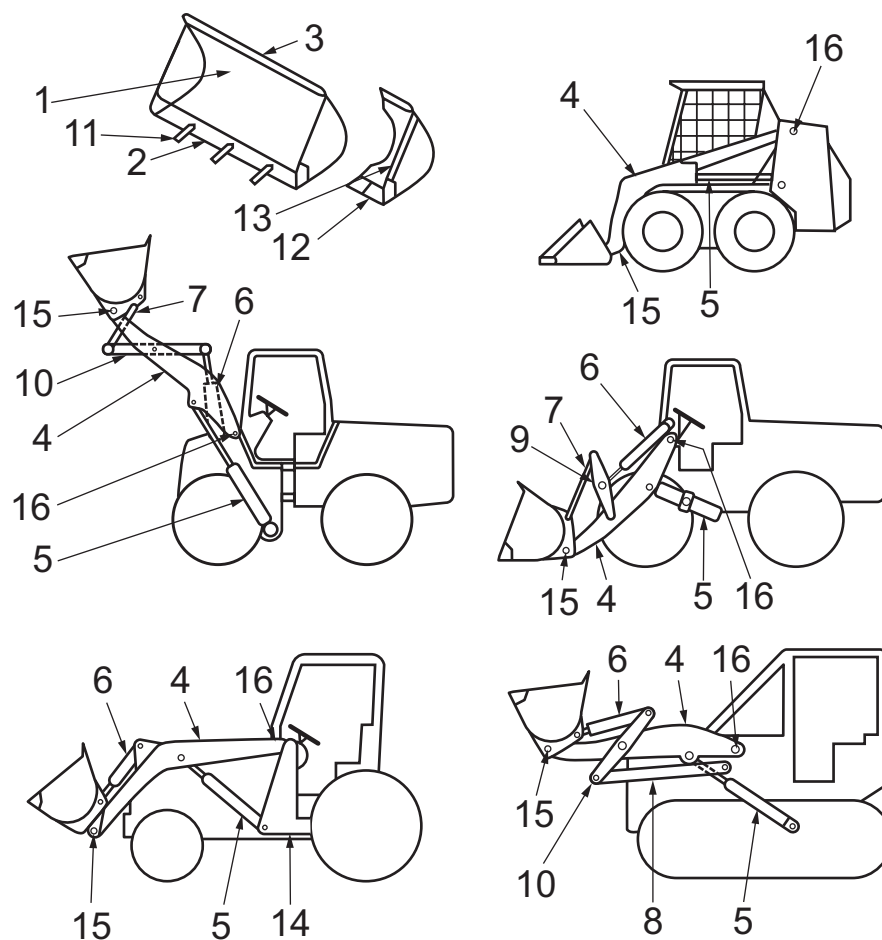

Key

1 bucket	9 lever, bucket
2 cutting edge	10 link, Z-bar
3 spill guard	11 tooth, bucket
4 lift arm	12 cutter, corner
5 cylinder, lift	13 cutter, side
6 cylinder, bucket	14 frame, loader (where separate from machine main frame)
7 link, bucket	15 pin, bucket hinge
8 link, guide	16 pin, lift arm hinge

Figure 16 — Loader equipment and attachment nomenclature

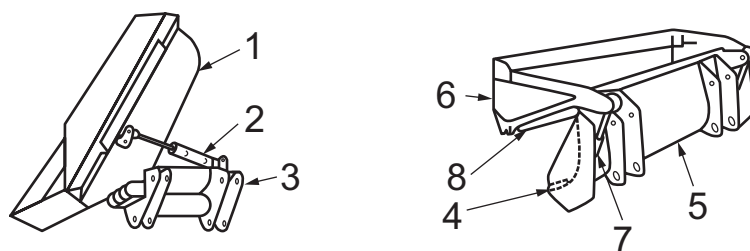

Key

- 1 bucket
- 2 cylinder, side dump
- 3 bucket support with carrier
- 4 cutting edge, mouldboard
- 5 mouldboard
- 6 clam section
- 7 cylinder, clam
- 8 clam cutting edge

Figure 17 — Loader attachment nomenclature

5.2 Dimensions

Figures 18 to 24 show the dimensions of the various equipment and attachments that can be installed on loaders.

See Annex A for the definitions of the dimensions.

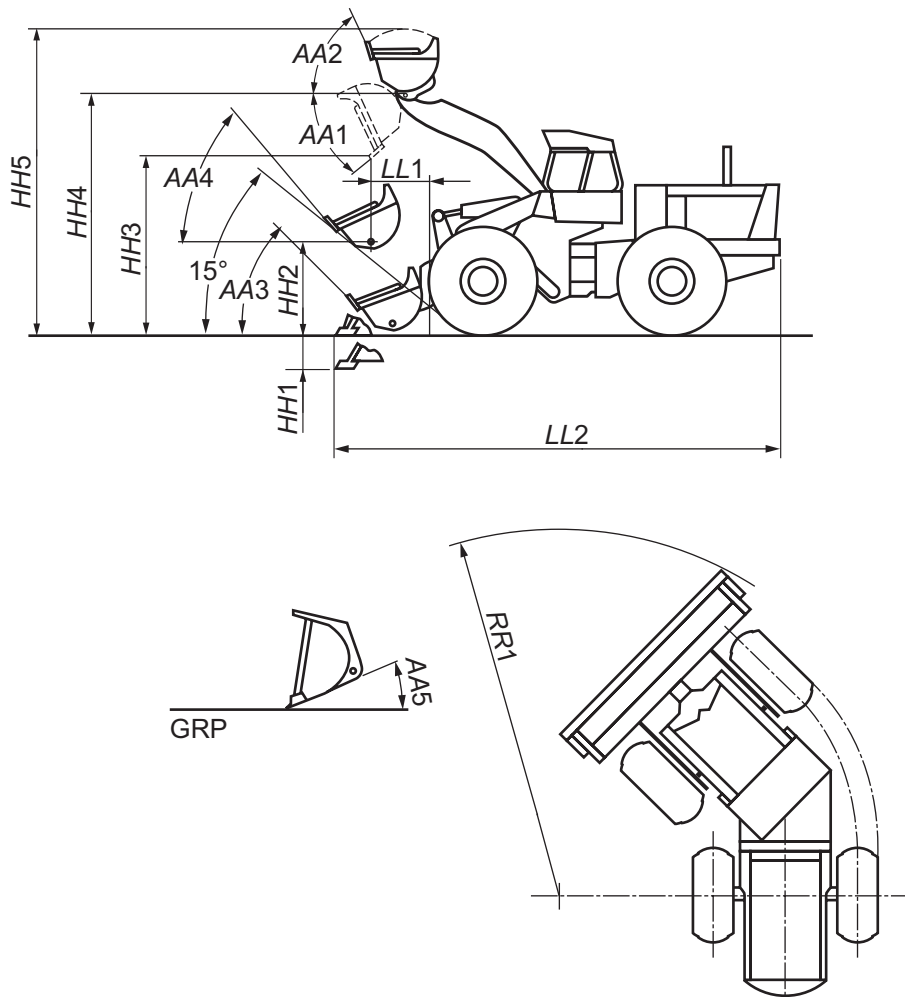

Figure 18 — Dimensions of equipment and bucket installed on loaders

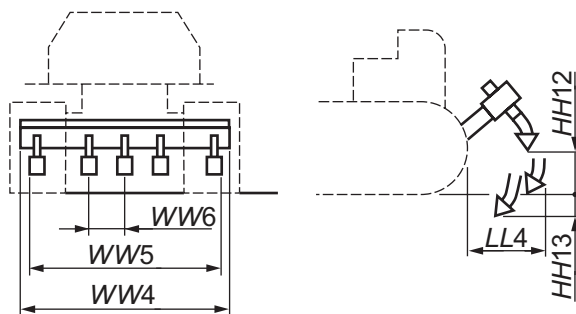

Figure 19 — Dimensions of equipment and scarifier installed on loaders

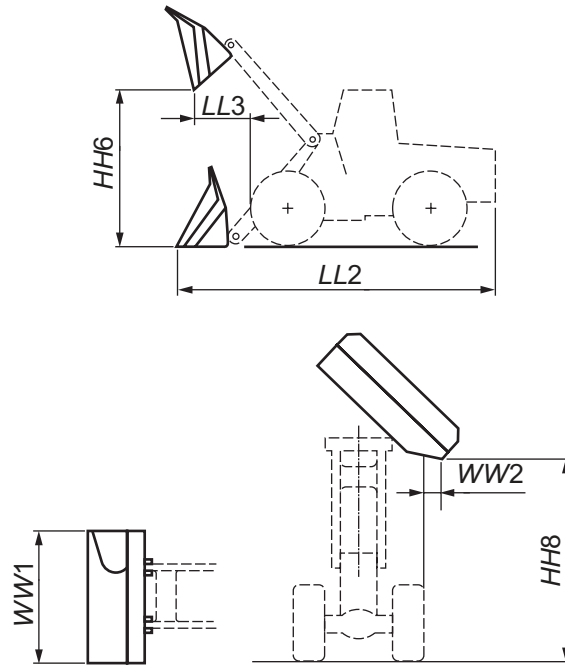

Figure 20 — Dimensions of equipment and side dump bucket installed on loaders

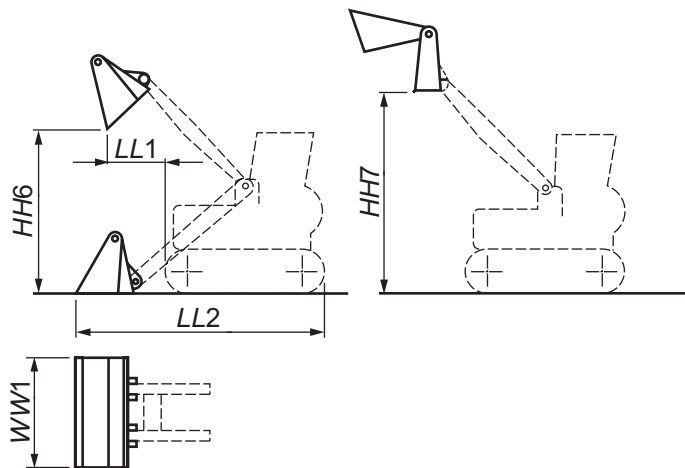

Figure 21 — Dimensions of equipment and multi-purpose bucket installed on loaders

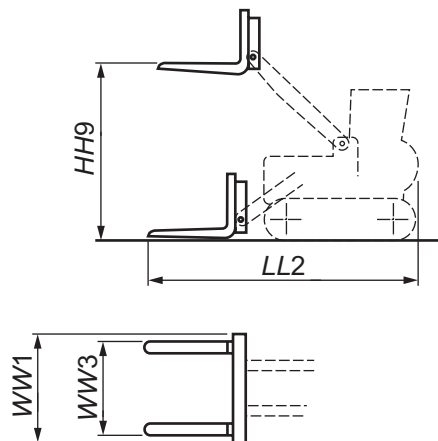

Figure 22 — Dimensions of equipment and fork installed on loaders

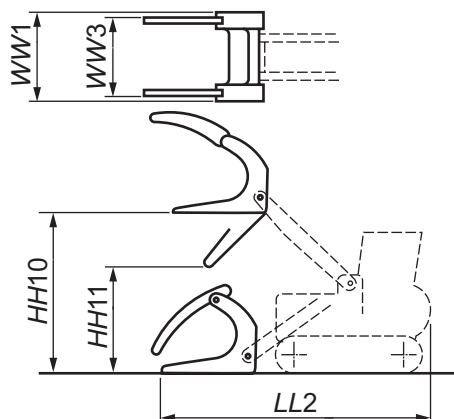

Figure 23 — Dimensions of equipment and log fork [log grapple] installed on loaders

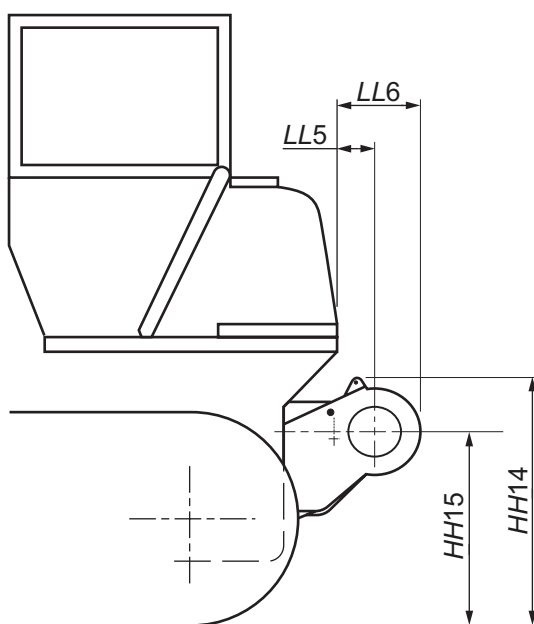

Figure 24 — Dimensions of equipment and winch installed on loaders

6 Performance terminology

6.1 Net power (engine)

See ISO 9249 and ISO 14396.

6.2 Tipping load at maximum reach

See ISO 14397-2.

6.3 Lift capacity to maximum height

See ISO 14397-2.

6.4 Rated operating capacity

See ISO 14397-1.

6.5 Breakout force

See ISO 14397-2.

6.6 Raising time

This is the minimum time required to raise the empty bucket with the stated operating load from the lowest position possible and fully rolled back to full height.

6.7 Lowering time

This is the minimum time required to lower the empty bucket from full height to the lowest possible position with the bucket bottom lying on the ground reference plane (GRP).

6.8 Dump time

This is the minimum time required to rotate the bucket from the maximum rollback — not exceeding the horizontal strike plane — fully raised position to the full dump position while dumping an operating load.

6.9 Maximum travel speeds

These are the maximum speeds that can be obtained on a hard level surface in each of the forward and reverse gear ratios with the bucket empty (see ISO 6014).

6.10 Braking performance

6.10.1 See ISO 3450 for wheeled loaders.

6.10.2 See ISO 10265 for crawler loaders.

6.11 Turning radius

See ISO 7457.

6.12 Lift capacity to maximum height

See ISO 14397-2.

7 Commercial literature specifications

7.1 General

This clause defines the information to be specified in the commercial literature.

SI (international system) units shall be used.

The following characteristics can be affected by bucket selection on machines equipped with non-standard tyres:

- bucket capacity (nominal heaped);
- overall operating height;
- overall length;

- dump angle;
- dump height;
- reach, fully raised;
- rollback (specify height);
- maximum rollback at ground;
- carry position;
- maximum rollback at carry position;
- digging depth;
- bucket width;
- maximum grading angle;
- operating mass¹⁾;
- operating load;
- tipping load¹⁾;
- tipping load (at specified height)¹⁾;
- breakout force¹⁾;
- machine clearance radius²⁾.

7.2 Engine

The following information shall be specified:

- a) ignition type, i.e. diesel or spark-ignition;
- b) form of air aspiration, i.e. naturally aspirated, mechanically supercharged or turbocharged;
- c) number of cylinders.

Other information that may also be specified includes

- d) manufacturer and model,
- e) type of cycle, i.e. two- or four-stroke,
- f) bore,
- g) stroke,
- h) displacement,

1) Can be further affected by tyre selection, tyre ballast, counterweight or attachments.

2) Can be further affected by tyre selection.

- i) net flywheel power at a given engine speed,
- j) maximum torque at a given engine speed,
- k) cooling system, i.e. air- or liquid-cooled,
- l) fuel type,
- m) starter type, and
- n) electrical system voltage.

7.3 Transmission

The transmission type shall be specified.

EXAMPLE Manual shift with flywheel clutch, powershift with torque converter, hydrostatic, electric.

Other information that may be specified in relation to the transmission includes

- number of speeds (forward and reverse), and
- maximum travel speeds (forward, reverse).

7.4 Hydraulic system

The following shall be specified:

- a) pump flow at a given pressure, at given engine speed;
- b) maximum normal system operating pressure.

Other additional hydraulic-system-related information may also be specified.

7.5 Filtration system

The type of filtration system may be specified.

7.6 Brakes

The following may be specified:

- a) type and actuating system of
 - 1) service brakes,
 - 2) parking brakes, and
 - 3) secondary brakes;
- b) brake performance.

7.7 Additional information for crawler loaders

7.7.1 Steering

The type of steering shall be specified.

7.7.2 Final drive

The type of final drive may be specified.

EXAMPLE Type (single or double reduction, planetary), ratio, lubrication.

7.7.3 Track

The following shall be specified:

- a) type;
- b) dimensions.

The following may also be specified:

- c) ground contact area;
- d) number of shoes (each side);
- e) number of carrier rollers (each side);
- f) number of track rollers (each side).

7.8 Additional information for wheeled loaders

7.8.1 Driving axle

The type of driving axle may be specified.

EXAMPLE Fixed versus oscillating, bevel gear and pinion, differential, two-speed, hydrostatic, planetary final drive.

7.8.2 Steering

The type of steering shall be specified.

Other related information that may be specified includes

- turning radius (left and right),
- articulation angle, and
- machine clearance diameter.

7.8.3 Tyres

The size and type of the tyres shall be specified.

Other related information that may be specified includes

- a) tread,
- b) ply rating, and
- c) rim size.

7.9 System fluid capacities

The following information shall be specified:

- a) fuel tank;
- b) hydraulic system.

Other related information that may be specified includes

- c) hydraulic tank,
- d) cooling system,
- e) engine crankcase,
- f) final drive case,
- g) pump drives, and
- h) swing drive case.

7.10 Masses

The operating mass and the shipping mass shall be specified.

Annex A (normative)

Loader equipment and attachments — Dimensions

This annex defines, in accordance with ISO 6746-2, loader equipment and attachment dimensions and their identifying terms and codes (see also Figures 18 to 24).

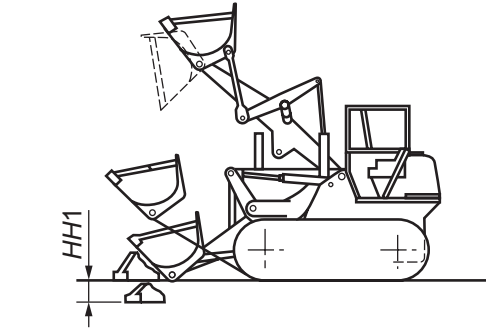
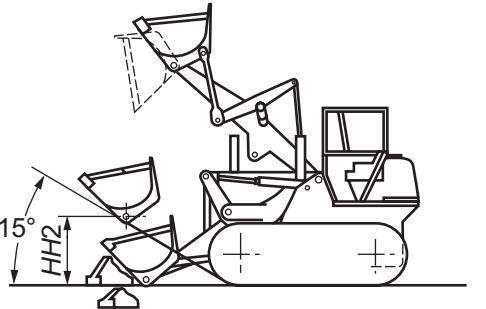
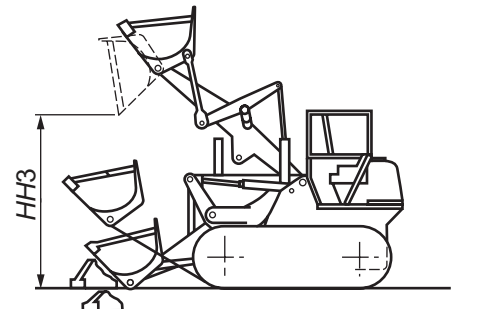
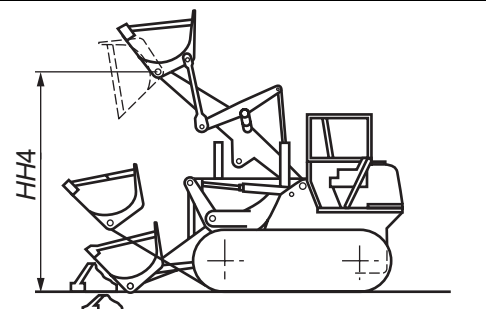
Code	Term	Definition	Illustration
<i>HH1</i>	Digging depth	Distance on Z coordinate between the ground reference plane (GRP) and the bottom of the bucket cutting edge at the lowest position with the bucket cutting edge horizontal.	
<i>HH2</i>	Carry position (height)	Distance on Z coordinate between the GRP and the centreline of the bucket hinge pin, with the angle of approach at 15° to the lowest point of the bucket or lift arms, whichever is the lower, with the bucket at maximum rollback.	
<i>HH3</i>	Dump height	Distance on Z coordinate between the GRP and the lowest point of the cutting edge, with the bucket hinge pin at maximum height and the bucket at a 45° dump angle. If the dump angle is less than 45°, specify the angle.	
<i>HH4</i>	Height to hinge pin, fully raised	Distance on Z coordinate between the GRP and the centreline of the bucket hinge pin with a fully raised bucket.	

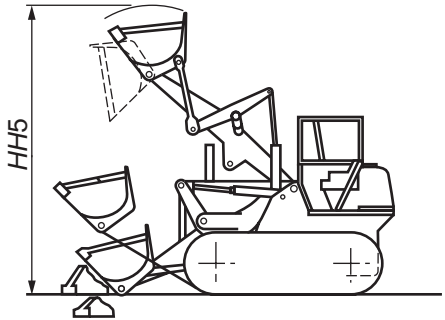
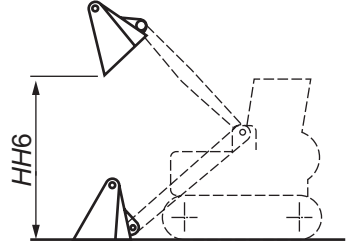
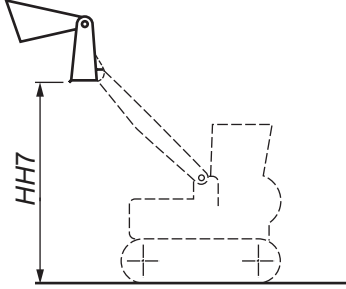
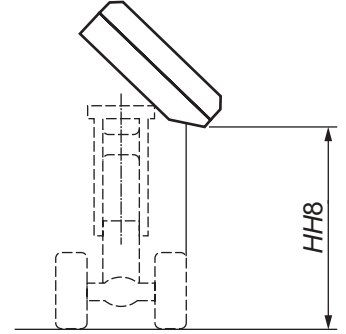
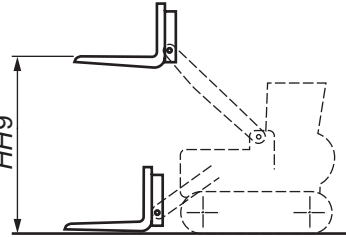
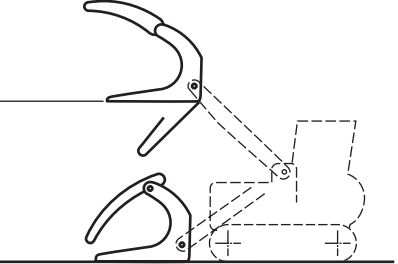
Code	Term	Definition	Illustration
<i>HH5</i>	Overall operating height, fully raised	Distance on Z coordinate between the GRP and the highest point obtainable with a fully raised bucket.	
<i>HH6</i>	Maximum dump height, clam closed	Distance on Z coordinate between the GRP and the lowest point on the bucket cutting edge, (clam closed), with the bucket hinge at maximum height and the bucket at maximum dump angle.	
<i>HH7</i>	Maximum dump height, clam open	Distance on Z coordinate between the GRP and the lowest point on the mouldboard cutting edge (clam open), with the bucket hinge pin at maximum height and the bottom of the mouldboard section of the bucket horizontal.	
<i>HH8</i>	Maximum dump height, side	Distance on Z coordinate between the GRP and the lowest point of the side dumping edge, with the bucket hinge pin at maximum height and the bucket at maximum side dump angle.	
<i>HH9</i>	Maximum lift height, tines level	Distance on Z coordinate between the GRP and the upper surface of the tines, with the pallet fork hinge pin at maximum height and tines level.	
<i>HH10</i>	Height of level tines, fully raised	Distance on Z coordinate between the GRP and the lower surface of the tines, with the fork hinge pin at maximum height and tines level.	

Code	Term	Definition	Illustration
HH11	Height of tips of tines, fork fully raised and dumped	Distance on Z coordinate between the GRP and the tips of the tines, with the fork hinge pin at maximum height and in dump position.	
HH12	Maximum scarifier lift height	Distance on Z coordinate between GRP and the lowest point of the cutting edge of the mid-tooth.	
HH13	Maximum scarifier depth	Distance on Z coordinate between GRP and the scarifier teeth at the deepest point that can be reached vertically.	
HH14	Maximum height of winch	Distance on Z coordinate between the GRP and the uppermost point on the winch.	

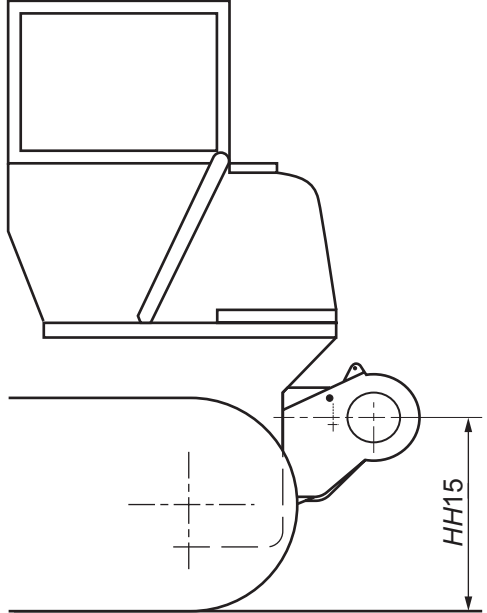
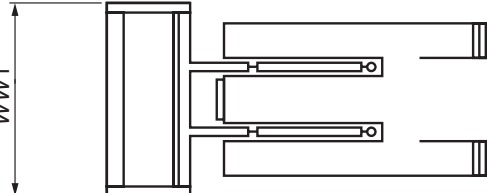
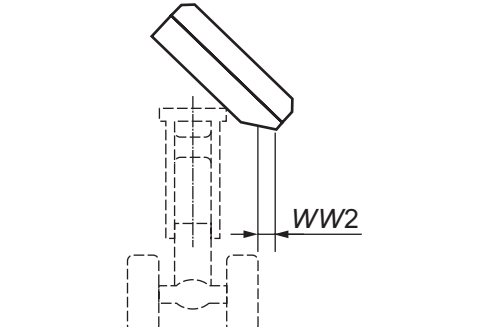
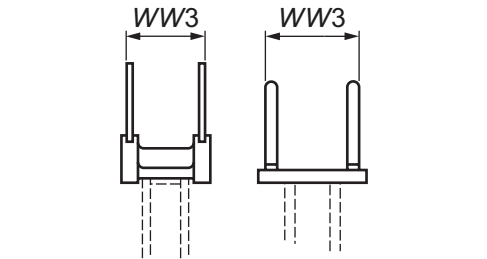
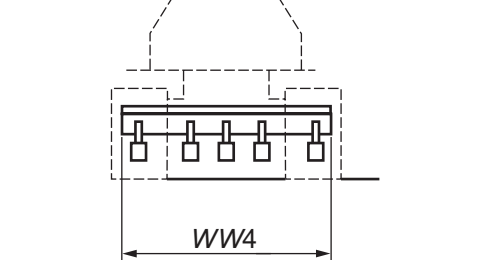
Code	Term	Definition	Illustration
<i>HH15</i>	Height of centre point of the winch	Distance on Z coordinate between the GRP and the centreline of the winch mechanism.	 <p>The illustration shows a side view of a winch mechanism. A horizontal dashed line represents the ground reference point (GRP). A vertical dimension line labeled 'HH15' indicates the distance from the GRP to the centerline of the winch mechanism.</p>
<i>WW1</i>	Attachment width	Distance on Y coordinate between two Y planes passing through the furthest point on the sides of the attachment.	 <p>The illustration shows a side view of an attachment mechanism. A vertical dimension line labeled 'WW1' indicates the distance between two vertical planes passing through the furthest points on the sides of the attachment.</p>
<i>WW2</i>	Maximum side dump reach	Distance on Y coordinate between two Y planes passing through the foremost point on the machine (including tyres, tracks or loader frames) and the foremost point on the bucket cutting edge, with the bucket hinge pin at maximum height and the bucket at maximum side dump angle.	 <p>The illustration shows a side view of a bucket at its maximum side dump angle. A horizontal dimension line labeled 'WW2' indicates the distance between two vertical planes: one passing through the foremost point of the machine and the other passing through the foremost point of the bucket cutting edge.</p>
<i>WW3</i>	Tines width	Distance on Y coordinate between two Y planes passing through the outside face of the external tines.	 <p>The illustration shows two side views of tines. A horizontal dimension line labeled 'WW3' indicates the distance between two vertical planes passing through the outside faces of the external tines.</p>
<i>WW4</i>	Scarifier width	Distance on Y coordinate between two Y planes passing through the furthest point on the sides of the scarifier.	 <p>The illustration shows a top view of a scarifier mechanism. A horizontal dimension line labeled 'WW4' indicates the distance between two vertical planes passing through the furthest points on the sides of the scarifier.</p>

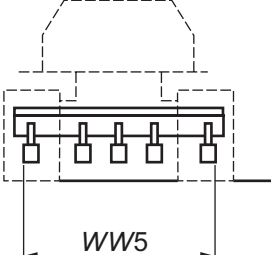
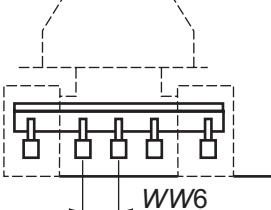
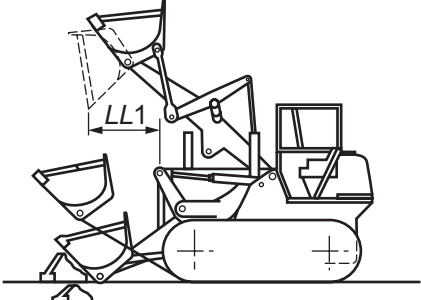
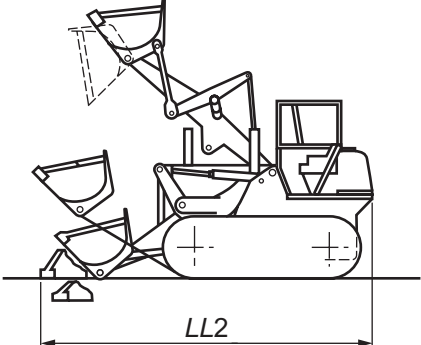
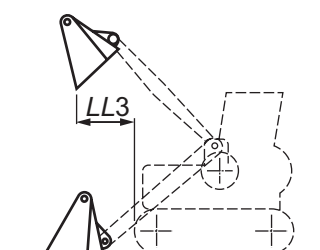
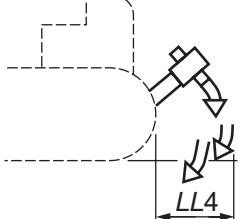
Code	Term	Definition	Illustration
WW5	Width of outer teeth of scarifier	Distance on Y coordinate between two Y planes passing through the outside face of external scarifier teeth.	
WW6	Scarifier teeth width	Distance on Y coordinate between two Y planes passing through the centre of adjacent scarifier teeth.	
LL1	Reach, fully raised	Distance on X coordinate between planes passing through the foremost point on the machine (including tyres, tracks or loader frame) and the foremost point on the cutting edge with the bucket hinge pin at maximum height and the bucket at a 45° dump angle. If the dump angle is less than 45°, specify the angle.	
LL2	Overall length (with attachment)	Distance on X coordinate between planes passing through the rearmost point on the machine and the foremost point of the attachment with the attachment bottom on the ground and level.	
LL3	Reach, fully raised	Distance on X coordinate between two X planes passing through the foremost point on the machine (including tyres, tracks or loader frames) and the rearmost point on the bucket cutting edge tip with the bucket hinge pin at maximum height and the bucket at maximum dump angle.	
LL4	Rearmost distance of scarifier	Distance on X coordinate between two X planes passing through the rearmost point on the machine (including tyres, tracks or loader frames) and the rearmost point on the scarifier when the scarifier tooth is level with the GRP.	

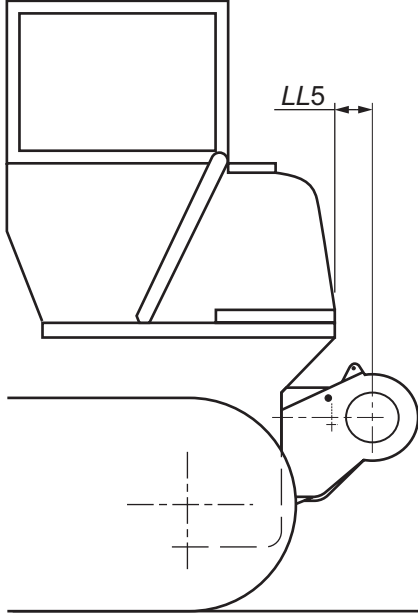
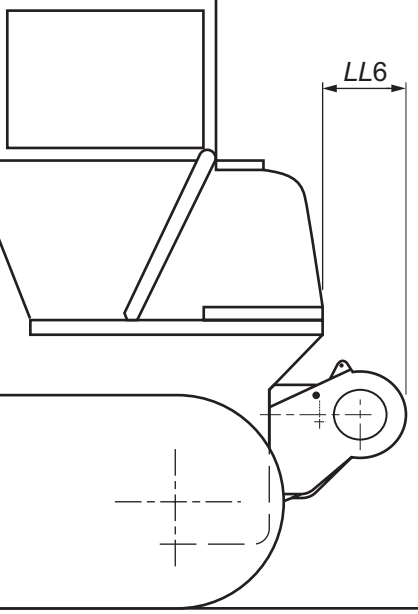
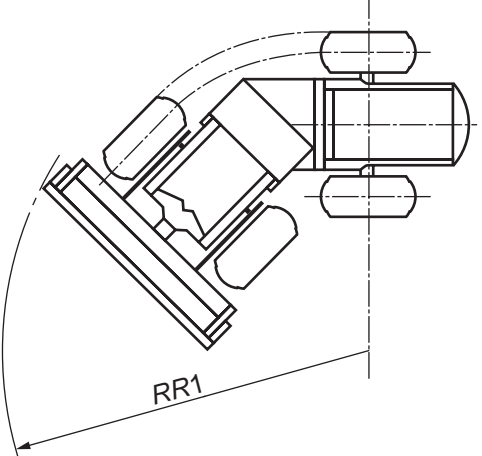
Code	Term	Definition	Illustration
LL5	Distance of centre point of winch from machine	Distance on X coordinate between two X planes passing through the rearmost point on the machine (including tyres, tracks or loader frames) and the centre point of the winching mechanism.	
LL6	Distance to rearmost point on attachment	Distance on X coordinate between two X planes passing through the rearmost point on the machine (including tyres, tracks or loader frames) and the rearmost point on the attachment.	
RR1	Minimum turning radius with bucket in carry position	Distance on Z plane between the turning centre and the farthest point on the side of the bucket when the machine is executing its smallest practicable turn.	

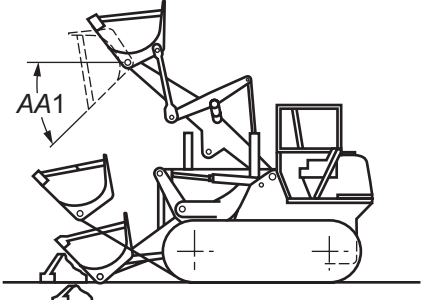
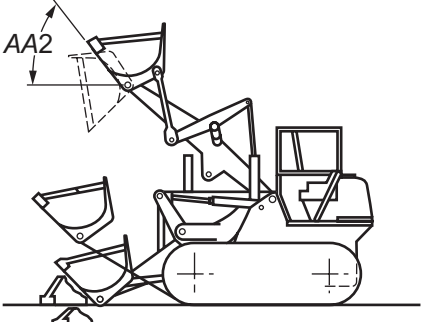
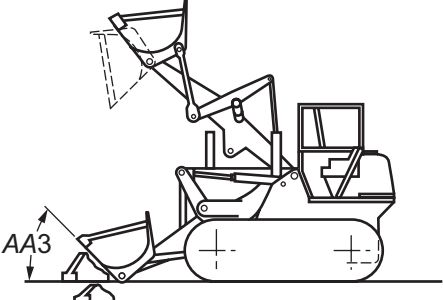
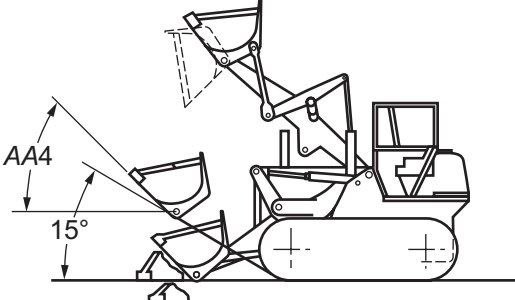
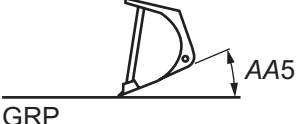
Code	Term	Definition	Illustration
A41	Dump angle	Maximum angle that the longest flat section of the inside bottom of the bucket will rotate below horizontal with the bucket in the fully raised position.	
A42	Maximum rollback, fully raised	Angle from the bucket cutting edge horizontal position to the maximum rollback position, lift arms fully raised.	
A43	Maximum rollback at ground	Maximum rollback angle without movement of the lift arm, starting with the bottom of the cutting edge on the GRP.	
A44	Maximum rollback at carry position	Angle from the bucket cutting edge horizontal position to the maximum rollback position, with lift arms in the carry position (see HH2).	
A45	Maximum grading angle	Maximum angle that the bucket cutting edge will rotate below the horizontal with the bucket cutting edge on the GRP.	

Bibliography

- [1] ISO 5010, *Earth-moving machinery — Rubber-tyred machines — Steering requirements*
- [2] ISO 8812, *Earth-moving machinery — Backhoe loaders — Definitions and commercial specifications*

British Standards Institution (BSI)

BSI is the national body responsible for preparing British Standards and other standards-related publications, information and services.

BSI is incorporated by Royal Charter. British Standards and other standardization products are published by BSI Standards Limited.

About us

We bring together business, industry, government, consumers, innovators and others to shape their combined experience and expertise into standards-based solutions.

The knowledge embodied in our standards has been carefully assembled in a dependable format and refined through our open consultation process. Organizations of all sizes and across all sectors choose standards to help them achieve their goals.

Information on standards

We can provide you with the knowledge that your organization needs to succeed. Find out more about British Standards by visiting our website at bsigroup.com/standards or contacting our Customer Services team or Knowledge Centre.

Buying standards

You can buy and download PDF versions of BSI publications, including British and adopted European and international standards, through our website at bsigroup.com/shop, where hard copies can also be purchased.

If you need international and foreign standards from other Standards Development Organizations, hard copies can be ordered from our Customer Services team.

Subscriptions

Our range of subscription services are designed to make using standards easier for you. For further information on our subscription products go to bsigroup.com/subscriptions.

With **British Standards Online (BSOL)** you'll have instant access to over 55,000 British and adopted European and international standards from your desktop. It's available 24/7 and is refreshed daily so you'll always be up to date.

You can keep in touch with standards developments and receive substantial discounts on the purchase price of standards, both in single copy and subscription format, by becoming a **BSI Subscribing Member**.

PLUS is an updating service exclusive to BSI Subscribing Members. You will automatically receive the latest hard copy of your standards when they're revised or replaced.

To find out more about becoming a BSI Subscribing Member and the benefits of membership, please visit bsigroup.com/shop.

With a **Multi-User Network Licence (MUNL)** you are able to host standards publications on your intranet. Licences can cover as few or as many users as you wish. With updates supplied as soon as they're available, you can be sure your documentation is current. For further information, email bsmusales@bsigroup.com.

BSI Group Headquarters

389 Chiswick High Road London W4 4AL UK

Revisions

Our British Standards and other publications are updated by amendment or revision.

We continually improve the quality of our products and services to benefit your business. If you find an inaccuracy or ambiguity within a British Standard or other BSI publication please inform the Knowledge Centre.

Copyright

All the data, software and documentation set out in all British Standards and other BSI publications are the property of and copyrighted by BSI, or some person or entity that owns copyright in the information used (such as the international standardization bodies) and has formally licensed such information to BSI for commercial publication and use. Except as permitted under the Copyright, Designs and Patents Act 1988 no extract may be reproduced, stored in a retrieval system or transmitted in any form or by any means – electronic, photocopying, recording or otherwise – without prior written permission from BSI. Details and advice can be obtained from the Copyright & Licensing Department.

Useful Contacts:

Customer Services

Tel: +44 845 086 9001

Email (orders): orders@bsigroup.com

Email (enquiries): cservices@bsigroup.com

Subscriptions

Tel: +44 845 086 9001

Email: subscriptions@bsigroup.com

Knowledge Centre

Tel: +44 20 8996 7004

Email: knowledgecentre@bsigroup.com

Copyright & Licensing

Tel: +44 20 8996 7070

Email: copyright@bsigroup.com



...making excellence a habit.™