

BS ISO 7121:2016



BSI Standards Publication

Steel ball valves for general-purpose industrial applications

bsi.

...making excellence a habit.™

National foreword

This British Standard is the UK implementation of ISO 7121:2016. It supersedes BS ISO 7121:2006 which is withdrawn.

The UK participation in its preparation was entrusted to Technical Committee PSE/18/1, Industrial valves, steam traps, actuators and safety devices against excessive pressure - Valves - Basic standards.

A list of organizations represented on this committee can be obtained on request to its secretary.

This publication does not purport to include all the necessary provisions of a contract. Users are responsible for its correct application.

© The British Standards Institution 2016.
Published by BSI Standards Limited 2016

ISBN 978 0 580 90035 8

ICS 23.060.20

Compliance with a British Standard cannot confer immunity from legal obligations.

This British Standard was published under the authority of the Standards Policy and Strategy Committee on 30 April 2016.

Amendments issued since publication

Date	Text affected
------	---------------

INTERNATIONAL
STANDARD

BS ISO 7121:2016

ISO
7121

Third edition
2016-04-15

**Steel ball valves for general-purpose
industrial applications**

*Robinets en acier à tournant sphérique pour les applications
industrielles générales*



Reference number
ISO 7121:2016(E)

© ISO 2016



COPYRIGHT PROTECTED DOCUMENT

© ISO 2016, Published in Switzerland

All rights reserved. Unless otherwise specified, no part of this publication may be reproduced or utilized otherwise in any form or by any means, electronic or mechanical, including photocopying, or posting on the internet or an intranet, without prior written permission. Permission can be requested from either ISO at the address below or ISO's member body in the country of the requester.

ISO copyright office
Ch. de Blandonnet 8 • CP 401
CH-1214 Vernier, Geneva, Switzerland
Tel. +41 22 749 01 11
Fax +41 22 749 09 47
copyright@iso.org
www.iso.org

Contents

Page

Foreword	v
Introduction	vi
1 Scope	1
2 Normative references	1
3 Terms and definitions	2
4 Pressure/temperature ratings	3
4.1 Valve rating.....	3
4.2 Shell rating.....	3
4.3 Seat and seal rating.....	3
5 Design	4
5.1 Flow passageway.....	4
5.2 Body.....	5
5.2.1 Body wall thickness.....	5
5.2.2 Flanged ends.....	8
5.2.3 Butt-welding ends.....	8
5.2.4 Socket welding ends.....	8
5.2.5 Threaded ends.....	9
5.2.6 Body openings.....	9
5.2.7 Anti-static design.....	9
5.2.8 Anti-blow-out stem.....	10
5.2.9 Ball-stem construction.....	10
5.2.10 Ball construction.....	10
5.2.11 Operating means.....	10
5.2.12 Glands.....	11
5.2.13 End flange facing interruptions.....	11
5.2.14 Shell joints.....	12
5.2.15 Packing gland bolting.....	13
6 Materials	13
6.1 Shell.....	13
6.2 Shell material repair.....	14
6.3 Trim.....	14
6.4 Identification plate.....	14
6.5 Bolting.....	14
6.6 Seals.....	14
6.7 Threaded plugs.....	14
7 Marking	14
7.1 Legibility.....	14
7.2 Body marking.....	14
7.3 Ring joint marking.....	15
7.4 Identification plate.....	15
7.5 Special marking for unidirectional valves.....	15
8 Testing and inspection	16
8.1 Pressure tests.....	16
8.1.1 General.....	16
8.1.2 Shell test.....	16
8.1.3 Closure tightness test.....	16
8.2 Inspection.....	17
8.3 Examination.....	17
8.4 Supplementary examination.....	18
9 Preparation for despatch	18

Annex A (informative) Information to be specified by the purchaser	19
Annex B (informative) Identification of valve parts	20
Bibliography	22

Foreword

ISO (the International Organization for Standardization) is a worldwide federation of national standards bodies (ISO member bodies). The work of preparing International Standards is normally carried out through ISO technical committees. Each member body interested in a subject for which a technical committee has been established has the right to be represented on that committee. International organizations, governmental and non-governmental, in liaison with ISO, also take part in the work. ISO collaborates closely with the International Electrotechnical Commission (IEC) on all matters of electrotechnical standardization.

The procedures used to develop this document and those intended for its further maintenance are described in the ISO/IEC Directives, Part 1. In particular the different approval criteria needed for the different types of ISO documents should be noted. This document was drafted in accordance with the editorial rules of the ISO/IEC Directives, Part 2 (see www.iso.org/directives).

Attention is drawn to the possibility that some of the elements of this document may be the subject of patent rights. ISO shall not be held responsible for identifying any or all such patent rights. Details of any patent rights identified during the development of the document will be in the Introduction and/or on the ISO list of patent declarations received (see www.iso.org/patents).

Any trade name used in this document is information given for the convenience of users and does not constitute an endorsement.

For an explanation on the meaning of ISO specific terms and expressions related to conformity assessment, as well as information about ISO's adherence to the World Trade Organization (WTO) principles in the Technical Barriers to Trade (TBT) see the following URL: www.iso.org/iso/foreword.html.

The committee responsible for this document is ISO/TC 153, *Valves*.

This third edition cancels and replaces the second edition (ISO 7121:2006), which has been technically revised with the following changes:

- in the scope DN 600, NPS 20 and 24, Class 800 and a note on the applicability of this Class were added;
- the normative references were updated;
- definitions for DN, NPS, PN and Class were added;
- a line for DN 600 was added in [Table 2](#);
- a line for DN 600 and a column for Class 800 were added in [Table 3](#);
- a column for DN 600 was added in [Table 4](#);
- a column for Class 800 was added in [Table 6](#);
- in [Tables 7](#) and [8](#), DN is up to 600;
- in [5.2.12.3](#), vertically split glands are not allowed anymore; [Annex A](#) was updated accordingly;
- 8.2.2 on site inspection was deleted; [Annex A](#) was updated accordingly.

Introduction

The purpose of this International Standard is the establishment, in ISO format, of basic requirements and practices for flanged, butt-welding, socket welding and threaded-end steel ball valves having flow passageways identified as full bore, reduced bore and double reduced bore, suitable for general purpose applications. Flanged end Class designated valves have flanges in accordance with ASME B16.5. Flanged end PN designated valves have flanges in accordance with EN 1092-1. Valves with ends that are threaded can have threads to either ISO 7-1 or ASME B1.20.1.

Steel ball valves for general-purpose industrial applications

1 Scope

This International Standard specifies the requirements for a series of steel ball valves suitable for general-purpose industrial applications.

It covers valves of the nominal sizes

- DN 8, 10, 15, 20, 25, 32, 40, 50, 65, 80, 100, 150, 200, 250, 300, 350, 400, 450, 500, and 600 (NPS 1/4, 3/8, 1/2, 3/4, 1, 1 1/4, 1 1/2, 2, 2 1/2, 3, 4, 6, 8, 10, 12, 14, 16, 18, 20 and 24),

and is applicable to the following pressure designations:

- PN 10; 16; 25; 40; 63; 100;
- Class 150; 300; 600; 800; 900.

NOTE Valve characteristics are not necessarily available in all nominal sizes for all pressure designations. For example, Class 800 applies only for valves with threaded end and socket weld ends up to DN 65 (NPS 2 1/2) and Class 900 applies only for reduced bore body seat openings.

It includes provisions for valve characteristics as follows:

- flanged and butt-welded ends in sizes $15 \leq DN \leq 600$ ($1/2 \leq NPS \leq 24$);
- socket welding ends in sizes $8 \leq DN \leq 100$ ($1/4 \leq NPS \leq 4$);
- threaded ends in sizes $8 \leq DN \leq 50$ ($1/4 \leq NPS \leq 2$);
- body seat openings designated as full bore, reduced bore and double reduced bore;
- materials;
- testing and inspection.

2 Normative references

The following documents, in whole or in part, are normatively referenced in this document and are indispensable for its application. For dated references, only the edition cited applies. For undated references, the latest edition of the referenced document (including any amendments) applies.

ISO 7-1, *Pipe threads where pressure-tight joints are made on the threads — Part 1: Dimensions, tolerances and designation*

ISO 7-2, *Pipe threads where pressure-tight joints are made on the threads — Part 2: Verification by means of limit gauges*

ISO 228-1, *Pipe threads where pressure-tight joints are not made on the threads — Part 1: Dimensions, tolerances and designation*

ISO 228-2, *Pipe threads where pressure-tight joints are not made on the threads — Part 2: Verification by means of limit gauges*

ISO 261, *ISO general purpose metric screw threads — General plan*

ISO 965-2, *ISO general purpose metric screw threads — Tolerances — Part 2: Limits of sizes for general purpose external and internal screw threads — Medium quality*

ISO 4032, *Hexagon regular nuts (style 1) — Product grades A and B*

ISO 4033, *Hexagon high nuts (style 2) — Product grades A and B*

ISO 4034, *Hexagon regular nuts (style 1) — Product grade C*

ISO 5208, *Industrial valves — Pressure testing of metallic valves*

ISO 5209, *General purpose industrial valves — Marking*

ISO 5752, *Metal valves for use in flanged pipe systems — Face-to-face and centre-to-face dimensions*

EN 1092-1, *Flanges and their joints — Circular flanges for pipes, valves, fittings and accessories, PN designated — Part 1: Steel flanges*

EN 1515-1:1999, *Flanges and their joints — Bolting — Part 1: Selection of bolting*

EN 12982, *Industrial valves — End-to-end and centre-to-end dimensions for butt welding end valves*

ASME B1.1, *Unified Inch Screw Threads, (UN and UNR Thread Form)*

ASME B1.20.1, *Pipe Threads, General Purpose, Inch*

ASME B16.5, *Pipe Flanges and Flanged Fittings: NPS 1/2 through NPS 24 Metric/Inch Standard*

ASME B16.10, *Face-to-Face and End-to-End Dimensions of Valves*

ASME B16.34:2013, *Valves Flanged, Threaded and Welding End*

ASME B18.2.2, *Nuts for General Applications: Machine Screw Nuts, Hex, Square, Hex Flange, and Coupling Nuts (Inch Series)*

MSS-SP-55,¹⁾ *Quality Standard for Steel Castings for Valves, Flanges and Fittings and Other Piping Components — Visual Method for Evaluation of Surface Irregularities*

3 Terms and definitions

For the purposes of this document, the following terms and definitions apply.

3.1

DN or NPS

alphanumeric designation of size that is common for components used in a piping system, used for reference purposes, comprising the letters DN or NPS followed by a dimensionless number indirectly related to the physical size of the bore or outside diameter of the end connections

Note 1 to entry: The number following DN or NPS does not represent a measurable value and is not used for calculation purposes except where specified in a product standard.

Note 2 to entry: See ISO 6708 and ASME B16.34.

1) Manufacturers Standardization Society standard.

3.2

PN or Class

alphanumeric designation for pressure-temperature rating that is common for components used in a piping system, used for reference purposes, comprising the letters “PN or Class” followed by a dimensionless number indirectly related to the pressure retaining capability as a function of temperature of the component

Note 1 to entry: The number following PN or Class does not represent a measurable value and is not used for calculation purposes except where specified in a product standard. There is no definitive correlation that links PN designations to Class designations.

Note 2 to entry: See ISO 7268, EN 1333 and ASME B16.34.

3.3

service pressure/temperature rating

lesser of the shell or seat pressure/temperature rating

3.4

anti-static design

design that provides for electrical continuity between the body, ball and stem of the valve

3.5

anti-blow-out design

design that ensures the valve stem cannot be ejected from the body in the event of the gland being removed while the valve is under pressure

4 Pressure/temperature ratings

4.1 Valve rating

The service pressure/temperature rating applicable to valves specified in this International Standard shall be the littlest of the shell rating (4.2) or the seat rating (4.3).

4.2 Shell rating

4.2.1 The pressure/temperature ratings applicable to the valve pressure containing shell (the pressure boundary elements, e.g. body, body cap, trunnion cap, cover, body inserts) shall be in accordance with that specified in the pressure/temperature tables of either ASME B16.34, Standard Class, for Class designated valves, or EN 1092-1 for PN designated valves.

4.2.2 The temperature for a corresponding shell pressure rating is the maximum temperature that is permitted for the pressure-containing shell of the valve. In general, this maximum temperature is that of the contained fluid. The use of a pressure rating corresponding to a temperature other than that of the contained fluid is the responsibility of the user. For temperatures below, the lowest temperature listed in the pressure/temperature tables (see 4.2.1), the service pressure shall be no greater than the pressure for the lowest listed temperature. Consideration should be given to the loss of ductility and impact strength of many materials at low temperature.

4.3 Seat and seal rating

4.3.1 Non-metallic elements, for example, seat, seals or stem seals, can impose restrictions on the applied pressure/temperature rating. Any such restriction shall be shown on the valve identification plate in accordance with 7.4.

4.3.2 The design shall be such that, when either polytetrafluoroethylene (PTFE) or reinforced PTFE is used for seats, the minimum valve pressure/temperature rating shall be as specified in Table 1. Designs

using these seating materials having pressure/temperature ratings less than those shown in [Table 1](#) are not in compliance with this International Standard.

4.3.3 Seat ratings for other seat materials shall be according to the manufacturer's standard. However, the assigned valve service pressure/temperature rating shall not exceed that of the valve shell.

Table 1 — Minimum seat pressure/temperature rating

Temperature ^b °C	PTFE seats ^a bar ^c				Reinforced PTFE seats ^a bar ^c			
	Floating ball			Trunnion	Floating ball			Trunnion
	DN ≤ 50 NPS ≤ 2	50 < DN ≤ 100 2 < NPS ≤ 4	DN > 100 NPS > 4	DN > 50 NPS > 2	DN ≤ 50 NPS ≤ 2	50 < DN ≤ 100 2 < NPS ≤ 4	DN > 100 NPS > 4	DN > 50 NPS > 2
-29 to 38	69,0	51,0	19,7	51,0	75,9	51,0	19,7	51,0
50	63,6	47,1	18,2	47,1	70,4	47,8	18,4	47,8
75	53,3	39,2	15,2	39,2	59,9	40,4	15,6	40,4
100	43,0	31,3	12,1	31,3	49,4	33,1	12,8	33,1
125	32,7	23,3	9,1	23,3	38,9	25,8	10,0	25,8
150	22,4	15,4	6,1	15,4	28,3	18,4	7,2	18,4
175	12,1	7,5	3,0	7,5	17,8	11,1	4,4	11,1
200	—	—	—	—	7,3	3,7	1,6	3,7
205	—	—	—	—	5,2	2,3	1,0	2,3

For a given PN or Class designation, the assigned valve pressure/temperature ratings shall not exceed the shell ratings, see [4.2](#).

^a Polytetrafluoroethylene seats.

^b Consult manufacturer for maximum design temperature rating of the valve seats.

^c 1 bar = 0,1 MPa = 10⁵ Pa; 1 MPa = 1 N/mm².

5 Design

5.1 Flow passageway

The flow passageway includes the circular seat opening in the ball and the body runs leading thereto. The body runs are the intervening elements that link the seat opening to the end connection, for example, to the thread end, weld end or socket end, or to the end-flange. Collectively, the flow passageway through the ball bore and body runs is referred to as the flow passageway. The ball bore is categorized in this International Standard as full bore, reduced bore and double reduced bore. The minimum effective diameter for each category shall be such that a hypothetical cylinder having a diameter according to [Table 2](#) can be passed through.

Table 2 — Cylindrical diameter for categorizing bore size

Nominal size DN	Minimum bore diameter mm					Nominal size NPS
	Full bore			Reduced bore	Double reduced bore	
	PN 10, 16, 25 and 40	PN 63	PN 100	PN: all	PN: all	
	Class 150 and 300	—	Class 600	Class: all	Class: all	
8	6	6	6	6	N/A	1/4
10	9	9	9	6	N/A	3/8
15	11	11	11	8	N/A	1/2
20	17	17	17	11	N/A	3/4
25	23	23	23	17	14	1
32	30	30	30	23	18	1 1/4
40	37	37	37	27	23	1 1/2
50	49	49	49	36	30	2
65	62	62	62	49	41	2 1/2
80	74	74	74	55	49	3
100	98	98	98	74	62	4
150	148	148	148	98	74	6
200	198	196	194	144	100	8
250	245	245	241	186	151	10
300	295	293	291	227	202	12
350	325	322	318	266	230	14
400	375	371	365	305	250	16
450	430	423	421	335	305	18
500	475	467	453	375	335	20
600	586	N/A	N/A	487	436	24

NOTE 1 N/A: Valves having this configuration are not within the scope of this International Standard.

NOTE 2 Full bore valves meeting the minimum bore diameter in this International Standard may not meet the minimum bore diameters of ISO 17292.

NOTE 3 For Class 900, only valves having reduced bore are within the scope of this International Standard.

5.2 Body

5.2.1 Body wall thickness

5.2.1.1 The minimum valve body wall thickness, t_m , shall be as specified in [Table 3](#), except that for butt-welding end valves the welding ends for connection to pipe shall be in accordance with the requirements of [Figure 1](#).

5.2.1.2 The minimum thickness requirements are applicable to, and are measured from, internally wetted surfaces, i.e. up to the point where body seals are effective.

Table 3 — Valve body wall thickness

PN	10 and 16			25 and 40			63			100			—	—	PN
Class	150			300			—			600			800	900 ^a	Class
Nom. size DN	Minimum valve body wall thickness, t_m mm														Nom. size NPS
	Full bore	Reduced bore	Double reduced bore	Full bore	Reduced bore	Double reduced bore	Full bore	Reduced bore	Double reduced bore	Full bore	Reduced bore	Double reduced bore	Full bore, reduced bore, double reduced bore	Reduced bore	
8	2,7	2,7	N/A	2,9	2,9	N/A	2,7	2,7	N/A	3,1	3,1	N/A	3,3	3,4	1/4
10	2,9	2,9	N/A	3,0	2,9	N/A	2,9	2,9	N/A	3,4	3,3	N/A	3,6	3,8	3/8
15	3,1	3,1	N/A	3,2	3,2	N/A	3,1	3,1	N/A	3,6	3,6	N/A	3,9	4,1	1/2
20	3,4	3,4	N/A	3,7	3,7	N/A	3,5	3,5	N/A	4,1	4,1	N/A	5,2	5,8	3/4
25	3,9	3,8	3,8	4,1	4,1	4,1	4,0	4,0	4,0	4,7	4,6	4,6	6,0	6,0	1
32	4,3	4,2	4,2	4,7	4,6	4,6	4,4	4,3	4,3	5,1	5,0	5,0	6,4	6,4	1 1/4
40	4,7	4,5	4,5	5,2	5,0	5,0	4,8	4,7	4,7	5,5	5,4	5,4	5,8	5,8	1 1/2
50	5,5	5,3	5,3	6,2	5,9	5,9	5,6	5,5	5,5	6,3	6,0	6,0	7,0	7,0	2
65	5,7	5,6	5,6	6,7	6,5	6,5	6,5	6,3	6,3	6,7	6,4	6,4	7,9	7,9	2 1/2
80	6	5,9	5,9	7,1	6,9	6,9	7,2	7,0	7,0	7,6	7,2	7,2	N/A	9,4	3
100	6,3	6,3	6,3	7,6	7,6	7,6	8,2	7,9	7,9	9,2	8,7	8,7	N/A	11,8	4
150	7,1	6,9	6,9	9,3	8,9	8,9	10,1	9,8	9,8	12,6	11,8	11,8	N/A	16,3	6
200	7,9	7,7	7,7	10,9	10,4	10,4	12,5	12,0	12,0	15,7	14,7	14,7	N/A	20,5	8
250	8,7	8,4	8,4	12,55	12,0	12,0	14,5	13,5	13,5	18,9	17,6	17,6	N/A	24,9	10
300	9,5	9,2	9,2	14,2	13,5	13,5	16,5	15,5	15,5	22,3	20,7	20,7	N/A	29,1	12
350	10	9,6	9,6	15,2	14,4	14,4	17,8	16,8	16,8	24,1	22,5	22,5	N/A	31,8	14
400	10,8	10,4	10,4	16,8	16	16	19,8	18,6	18,6	27,3	25,4	25,4	N/A	36,0	16
450	11,7	11,1	11,1	18,7	17,3	17,3	21,7	20,4	20,4	31,1	28,9	28,9	N/A	42,0	18
500	12,4	11,9	11,9	20,2	18,8	18,8	24,0	22,5	22,5	33,2	30,8	30,8	N/A	44,3	20
600	14,3	13,3	13,3	23,7	21,8	21,8	N/A	N/A	N/A	N/A	N/A	N/A	N/A	N/A	24

NOTE N/A: Valves having this configuration are not within the scope of this International Standard.

^a For Class 900, only valves having reduced ball ports are within the scope of this International Standard.

5.2.1.3 Local areas having less than minimum wall thickness are acceptable, provided that all of the following conditions are satisfied:

- the area of sub-minimum thickness can be enclosed by a circle, the diameter of which is not greater than $0,35\sqrt{d t_m}$, where d is the minimum bore diameter given in [Table 2](#) and t_m is the minimum wall thickness given in [Table 3](#);
- the measured thickness is not less than $0,75 t_m$;
- enclosed circles are separated from each other by an edge-to-edge distance of not less than $1,75\sqrt{d t_m}$.

5.2.1.4 The manufacturer, taking into account such factors as component bolting or thread assembly loads, rigidity needed for component alignment, other valve design details and the specified operating conditions is responsible for determining if a larger wall thickness is required.

Dimensions and tolerances in millimetres

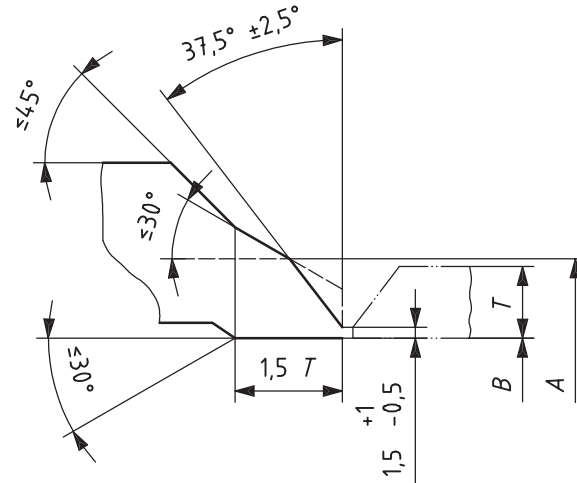

a) Welding end for connection to pipe of wall thickness $T \leq 22$ mm

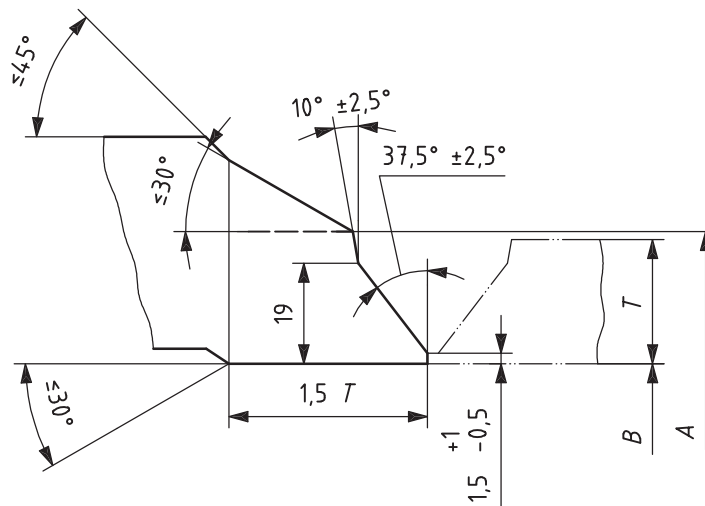

b) Welding end for connection to pipe of wall thickness $T > 22$ mm

Key

A nominal outside diameter of welding end (see [Table 4](#))

B nominal inside diameter of pipe (see [Table 4](#) for applicable tolerance)

T nominal wall thickness of pipe

The inside and outside surfaces of valve welding ends are machine finished overall. The contour outside the envelope formed by the end of the welding end and the dimension $1.5T$ is at the option of the manufacturer, unless specifically ordered otherwise.

Intersections should be slightly rounded.

Valves with minimum wall thickness equal to 3 mm or less may have ends cut square or slightly chamfered.

For nominal outside diameters and wall thickness of standard steel pipe, see ISO 4200 or ASME B36.10.

Figure 1 — Welding ends

Table 4 — Welding ends

Nominal size, DN		15	20	25	32	40	50	65	80	100	150	200	250	300	350	400	450	500	600		
Nominal size, NPS		1/2	3/4	1	1 1/4	1 1/2	2	2 1/2	3	4	6	8	10	12	14	16	18	20	24		
A, mm	diameter	22	28	35	44	50	62	78	91	117	172	223	278	329	362	413	464	516	619		
	tolerance	+2,5 -1,0										+4 -1									
B, mm	tolerance	+1 -1										+2 -2						+3 -2			

5.2.2 Flanged ends

5.2.2.1 Body end flanges shall comply with the requirements of ASME B16.5 for Class designated valves and EN 1092-1 for PN designated valves. Raised face end flanges shall be provided, unless otherwise specified by the purchaser.

5.2.2.2 Face-to-face dimensions for flanged-end valves shall be in accordance with ASME B16.10 for Class designated valves or ISO 5752, Basic Series 1, 14, and 27, for PN designated valves, with an applicable tolerance for DN ≤ 250 of ±2 mm and for DN ≥ 300 of ±4 mm.

5.2.2.3 End flanges shall be either cast or forged integral with the body or end piece of a split body design, or attached by welding by a qualified welder using an accepted welding procedure, with the condition that all such flanges on valves larger than DN 50 shall be butt-welded. Any heat treatment necessary to ensure that the material is suitable for the full range of service temperature shall be performed.

5.2.2.4 End flange facing finish shall be in accordance with ASME B16.5 for Class designated valves or EN 1092-1 for PN designated valves unless otherwise specified by the purchaser.

5.2.3 Butt-welding ends

5.2.3.1 Butt-welding ends shall be in accordance with [Figure 1](#) and [Table 4](#), unless otherwise specified by the purchaser.

5.2.3.2 End-to-end dimensions for Class designated valves shall be in accordance with ASME B16.10 for either the long or short pattern, or in accordance with EN 12982 for PN designated valves.

5.2.4 Socket welding ends

5.2.4.1 The socket bore axis shall coincide with the end entry axis. Socket end faces shall be perpendicular to the socket bore axis. The socket bore diameter and its depth shall be as specified in [Table 5](#).

5.2.4.2 The minimum socket wall thickness, extending over the full socket depth, shall be as specified in [Table 6](#).

5.2.4.3 End-to-end dimensions for socket welding end valves shall be established by the manufacturer.

Table 5 — Socket diameter and depth

DN	Diameter ^a mm	Depth ^b mm	NPS
8	14,1	9,5	1/4
10	17,5	9,5	3/8
15	21,7	10	1/2
20	27,0	13	3/4
25	33,8	13	1
32	42,5	13	1 1/4
40	48,6	13	1 1/2
50	61,1	16	2
65	73,8	16	2 1/2
80	89,7	16	3
100	115,1	19	4
^a The applicable diametral tolerance is — $\begin{matrix} +0,5 \\ 0 \end{matrix}$ for DN ≤ 50, and — $\begin{matrix} +0,7 \\ 0 \end{matrix}$ for DN > 50. ^b The depth dimension is a minimum value.			

5.2.5 Threaded ends

5.2.5.1 The threaded end thread axis shall coincide with the end entry axis. The minimum wall thickness at the threaded end shall be as specified in [Table 6](#). An approximate 45° lead-in chamfer, having an approximate depth of one-half the thread pitch, shall be applied at each threaded end.

5.2.5.2 The end threads shall be either taper or parallel pipe threads meeting the applicable requirements of ISO 7-1, ISO 228-1 or ASME B1.20.1, with threads gauged in accordance with ISO 7-2, ISO 228-2 or ASME B1.20.1, as applicable. The required pipe thread shall be specified in the purchase order.

5.2.5.3 End-to-end dimensions for threaded end valves shall be established by the manufacturer.

5.2.6 Body openings

Trunnion mounted valves that employ upstream sealing seats shall be fitted with a test plug, DN 15 (NPS 1/2) or smaller, having threads in accordance with [5.2.5.2](#), in order to complete the closure tightness test. Other tapped openings, for any purpose, are permitted only when specified by the purchaser.

5.2.7 Anti-static design

When specified in the purchase order, valves shall incorporate an antistatic feature that ensures electrical continuity between stem and body of valves DN ≤ 50 and between ball, stem and body of larger valves. The antistatic feature shall have electrical continuity across the discharge path with a resistance not exceeding 10 Ω from a power source not exceeding 12 V d.c. when type tested on a new, dry, as-built valve after pressure testing and cycling of the valve at least five times.

Table 6 — Socket and threaded end wall thickness

PN	10, 16, 25 and 40	63 and 100	—	—	PN
Class	150 and 300	600	800	900	Class
DN	Minimum wall thickness mm				NPS
8	3,0	3,3	3,3	4,1	1/4
10	3,0	3,6	3,6	4,3	3/8
15	3,3	4,1	4,1	5,3	1/2
20	3,6	4,3	4,3	6,1	3/4
25	3,8	5,1	5,1	6,9	1
32	3,8	5,3	5,3	7,1	1 1/4
40	4,1	5,6	5,8	7,9	1 1/2
50	4,6	6,1	6,9	9,7	2
65	5,6	7,6	7,9	10,4	2 1/2
80	6,4	8,6	N/A	12,2	3
100	7,5	10,1	N/A	14,3	4

NOTE 1 N/A: Valves having this configuration are not within the scope of this International Standard.
NOTE 2 For threaded end valves, only sizes up to DN 50 are allowed by this International Standard.

5.2.8 Anti-blow-out stem

The valve design shall be such that the stem seal retaining device is not the sole means used to retain the stem. The design shall ensure that, while under pressure, the stem is not ejected from the valve by the disassembly of valve external parts, for example, gland and gland flange bolting. See [Annex B](#).

5.2.9 Ball-stem construction

5.2.9.1 The valve design shall be such that if a failure occurs either between the stem-to-ball connection or any part of the stem within the pressure boundary, no portion of the stem is ejected when the valve is under pressure.

5.2.9.2 Both the stem-to-ball connection and all of that part of the stem within the pressure boundary shall be designed to exceed the torsional strength of the stem external to the packing.

5.2.9.3 The stem and the connection between the stem and the ball shall be designed to preclude permanent deformation or failure of any part when a force applied to the direct operating lever or the operational means of a manual gear operator, whichever is furnished with the valve, transmits a torque to the valve stem equal to twice the manufacturer's maximum recommended torque.

5.2.9.4 The manufacturer's recommended torque shall be based on clean and non-lubricated liquids with a viscosity not higher than water at a differential pressure equal to the maximum differential service pressure.

5.2.10 Ball construction

The ball shall have a circular bore (flow passageway).

5.2.11 Operating means

5.2.11.1 Valves that are solely manually operated, i.e. without an attached gear or power-assist device, shall be fitted with lever-type handles unless otherwise specified by the purchaser.

5.2.11.2 Gear operators, when specified or required to meet the operating force requirements of [5.2.11.3](#), shall be provided with handwheels for actuation.

5.2.11.3 Unless otherwise specified by the purchaser, the length of the lever-type handle or the diameter of the manual gear handwheel shall be sized so that the applied input force needed to open or close the valve does not exceed 350 N at the manufacturer's recommended operating torque.

5.2.11.4 For lever-operated valves, position stops shall be provided at both the full open and full closed positions.

5.2.11.5 Valves shall be designed to close whenever the lever or handwheel is turned in a clockwise direction.

5.2.11.6 Handwheels on manual gear operators shall be marked to indicate either the direction of opening or closing.

5.2.11.7 Lever-type handles shall be mounted with the handle parallel to the ball bore. If the purchaser specifies round or oval direct operating handwheels, a permanent means of indicating the open and closed positions shall be provided.

5.2.11.8 Lever or manual gear box handwheel design shall be such that the lever- or gearbox- indicating means does not assemble in other than the correct configuration for indicating the open and closed positions.

5.2.11.9 An indication of the position of the flow passageway through the ball shall be integral with the valve stem. This indication may be by a permanent marking on the stem or by a shaping of the stem.

5.2.11.10 Levers, handwheels and other operating mechanisms shall be fitted to the valve such that they can be removed and replaced without affecting the integrity of the stem or body seal or retention of the stem.

5.2.12 Glands

5.2.12.1 Adjustable packing glands shall be accessible for tightening stem seals without the disassembly of either the valve or operator parts.

5.2.12.2 Packing glands that are threaded into bodies or covers (see [Annex B](#)) shall not be used for valve sizes DN > 200 (NPS > 8).

5.2.12.3 Vertically split glands shall not be used.

5.2.12.4 Position stops integral with the gland or gland flange shall not be used.

5.2.13 End flange facing interruptions

5.2.13.1 Ring-shaped radial gaps, located in what would be the seating face area of a centred spiral wound style gasket on the end-flange facing area of end flanges, shall not exceed 1,5 mm. The gap is shown as dimension *b* in [Figure 2](#). An example of the occurrence of this type of gap is one that can exist between the outer periphery of a body insert and the inner bore of the body end flange of the valve. This is shown in [Figure 2](#).

5.2.13.2 For ball valves designed with a body insert (see [Annex B](#)), with a gasket seating face outer diameter located within the seating area of a centred spiral wound gasket, the body insert flange face

shall not protrude beyond the valve body end flange face. The flange face on the body insert shall not be recessed below the body end flange face by more than 0,25 mm. The recess is shown as dimension *a* in [Figure 2](#).

5.2.13.3 Threads for body inserts (see [Figure 2](#)) shall have a thread shear area such that the resultant thread shear stress is ≤ 70 MPa at an internal pressure equal to the 38 °C pressure rating.

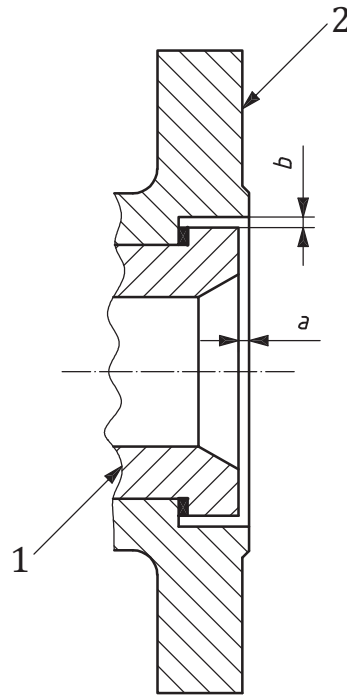

Key

- 1 body insert
- 2 valve body end flange

Figure 2 — Flange face interruption limits

5.2.14 Shell joints

5.2.14.1 Shell joints are characterized as bolted body-to-cap joints, threaded body-to-cap joints, bolted cover joints and threaded cover joints. Body-to-cap joints are those that can be subject to piping mechanical loads, whereas cover joints are not. See [Annex B](#) for a nomenclature of the parts.

5.2.14.2 Bolting used for assembly of shell joints shall be studs or continuously threaded stud bolts with nuts or cap screws. Nuts shall be semi-finished hexagons conforming to ASME B18.2.2, ISO 4032, ISO 4033 or ISO 4034. ASME-specified bolting of 25 mm diameter and smaller shall have coarse (UNC) threads. ASME-specified bolting larger than 25 mm diameter shall be 8 thread series (8UN). ASME-specified bolt threads shall be Class 2A and nut threads shall be Class 2B, conforming to ASME B1.1. Metric-specified bolting M30 and smaller shall have coarse threads. Metric-specified bolting larger than M30 shall be fine threads with 3 mm pitch. Metric-specified threads shall be in accordance with ISO 261 and ISO 965-2, tolerance class 6g.

5.2.14.3 Nut and bolt head bearing surfaces in shell joints assembled by bolting shall be perpendicular to the centreline of the tapped or clearance hole for the fastener with a tolerance of $\pm 1^\circ$.

5.2.14.4 A bolted body-to-body cap joint (see [Annex B](#) for nomenclature) shall be secured by a minimum of four bolts. The minimum bolt size shall be as follows:

- M10 or 3/8 for sizes $25 \leq DN \leq 65$;
- M12 or 1/2 for sizes $80 \leq DN \leq 200$;
- M16 or 5/8 for sizes $250 \leq DN$.

5.2.14.5 A bolted or threaded shell joint shall, as minimum, meet one of the following applicable requirements:

- bolted body-to-cap: $P_c \frac{A_g}{A_b} \leq 50,76 \leq 7\ 000$
- threaded body-to-cap: $P_c \frac{A_g}{A_s} \leq 3\ 300$
- bolted cover: $P_c \frac{A_g}{A_b} \leq 65,26 \leq 9\ 000$
- threaded cover: $P_c \frac{A_g}{A_s} \leq 4\ 200$

where

S_b is the allowable bolt stress at 38 °C, expressed in megapascals, except when greater than 138 MPa, in which case use 138 MPa;

P_c is for Class designated valves, the Class designation number, e.g. 600, or, for PN designated valves, the PN designation number multiplied by 6, e.g. for PN 40, use $40 \times 6 = 240$;

A_g is the area bounded by the effective outside periphery of the gasket, expressed in square millimetres (mm²);

A_b is the total effective bolt tensile stress area, expressed in square millimetres (mm²);

A_s is the total effective thread shear stress area, expressed in square millimetres (mm²).

5.2.14.6 At assembly, gasket contact surfaces shall be free of heavy oils, grease and sealing compounds. A light coating of a lubricant, no heavier than kerosene, may be applied if needed to assist in proper gasket assembly.

5.2.15 Packing gland bolting

5.2.15.1 When a packing gland is included, the packing gland bolting shall pass through holes in the gland. Open slots for bolting are not permitted in the cover flange, cover or gland.

5.2.15.2 Packing gland bolts shall be sized so that the bolt tensile stress does not exceed one-quarter of the ultimate tensile strength of the bolting material for a compressive packing stress of 38 MPa.

6 Materials

6.1 Shell

The shell, which comprises, as applicable, the body, body insert, body cap, cover and trunnion cap, shall be of a material specified in ASME B16.34 for Class designated valves or EN 1092-1 for PN designated valves. These shell parts are identified in [Annex B](#).

6.2 Shell material repair

Defects in cast or forged valve pressure shell materials that are revealed during manufacturing operations or testing may be repaired, as permitted by the most nearly applicable material specification for forgings or castings.

6.3 Trim

The internal metal parts of the valve, such as the ball, stem, metal seats or seat retainers, shall be corrosion resistant and have corrosion-resistant properties equivalent to or better than those of the shell. The purchaser may specify materials having greater corrosion resistance or higher strength for these parts.

6.4 Identification plate

Identification plates shall be of corrosion-resistant material and shall be attached by corrosion-resistant fastenings or by welding.

6.5 Bolting

Unless otherwise, specified by the purchaser, bolting materials for assembling shell pressure-retaining components shall be in accordance with ASME B16.34:2013, Table 1, Group 4, or EN 1515-1:1999, Table 2.

6.6 Seals

Material for stem seals, body seals, cover seals and gaskets shall be suitable for use at the maximum allowable temperature and its corresponding pressure rating applied to the valve by the manufacturer. Metallic parts used in seals shall have corrosion-resistant properties equivalent to or better than those of the shell material.

6.7 Threaded plugs

Threaded plugs used for sealing tapped openings shall have corrosion-resistant properties equivalent to or better than those of the shell. Malleable, grey or any other form of cast iron shall not be used for plugs.

7 Marking

7.1 Legibility

Each valve manufactured in accordance with this International Standard shall be clearly marked in accordance with ISO 5209, except that the following requirements shall apply.

7.2 Body marking

7.2.1 The mandatory valve body markings, subject to the provisions of [7.2.2](#), shall be as follows:

- manufacturer's name or trademark;
- body material;
- pressure rating as PN followed by the appropriate pressure number, e.g. PN 16, for PN designated valves, or pressure Class number, e.g. 150, for Class designated valves;
- nominal size, as either DN followed by the appropriate size number, e.g. DN 500, or the NPS number, e.g. 20.

7.2.2 For valves smaller than DN 50, if the size or shape of the valve body precludes the inclusion of all the required markings, one or more may be omitted provided that they are shown on the identification plate. The sequence of omission shall be as follows:

- nominal size;
- PN designation or Class number;
- body material.

7.3 Ring joint marking

Body end flanges require marking only when the end flanges are grooved for a ring type end flange gasket. When so grooved, the ring joint gasket number (e.g. R25) shall be marked on the rim of both end flanges. For ring joint gasket numbers, see ASME B16.5.

7.4 Identification plate

Each valve shall have an identification plate with the following marking:

- the manufacturer's name or trademark;
- pressure rating designation, PN or Class;
- manufacturer's identification number;
- maximum pressure at 38 °C;
- limiting temperature and associated pressure, if applicable;
- limiting differential pressure and associated temperature, if applicable;
- trim identification, e.g. PTFE;
- pipe thread identification, e.g. NPT or RC.

The number of this International Standard may be included, provided that all of its applicable requirements have been met.

7.5 Special marking for unidirectional valves

Valves designed for, or modified to have, only a unidirectional capability, i.e. the ability to block flow in only one direction, shall have a separate identification plate attached to the valve body to identify the unidirectional seat. The unidirectional seat shall be shown on the identification plate as shown in [Figure 3](#).

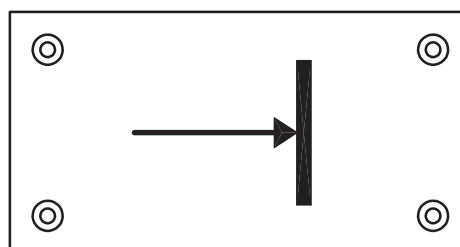

Figure 3 — Typical unidirectional valve identification plate symbol

8 Testing and inspection

8.1 Pressure tests

8.1.1 General

Each valve shall be given a shell pressure test, and a seat closure test in accordance with the requirements of ISO 5208 except as modified herein. Sealing compounds, greases, or oils shall be removed from seating surfaces prior to pressure testing. It is, however, permissible for metal-to-metal seating surfaces, to apply a film of oil that is not heavier than kerosene to prevent metallic galling.

8.1.2 Shell test

8.1.2.1 The shell test shall be at a pressure not less than 1,5 times the pressure corresponding to the valve 38 °C pressure rating. If the valve design includes an adjustable stem seal, it shall be adjusted so as to maintain the shell test pressure.

8.1.2.2 The duration of the shell test, the minimum period of time that the shell test pressure is to be sustained, shall be in accordance with [Table 7](#).

8.1.2.3 Over the duration of the shell test there shall be no visually detectable leakage through either the shell wall or any of the body seals.

Table 7 — Test duration

Valve size range	Minimum test duration	
	Shell test	Seat test
DN ≤ 50	15	15
65 ≤ DN ≤ 200	60	60
250 ≤ DN ≤ 300	120	120
350 ≤ DN ≤ 600	300	120

8.1.3 Closure tightness test

8.1.3.1 For valve designs having resilient seats, the closure tightness test shall be a gas test with the test gas at a pressure of between 4 bar and 7 bar (400 kPa and 700 kPa). For floating ball designs, the test method shall be one that fills the body cavity between the seats and the body ball chamber with test gas so as to ensure that no seat leakage can escape detection. For trunnion-mounted valves of upstream sealing design, the test method shall be one that measures leakage across the upstream seat. For trunnion-mounted valves of downstream sealing design, the test method shall be one that measures leakage across the downstream seat.

8.1.3.2 For valve designs having metal or ceramic seats, the closure tightness test shall be a liquid test with the test fluid at a pressure not less than 1,1 times the rated seat pressure at 38 °C (100 °F). For floating ball designs, the test method shall be one that fills the body cavity between the seats and the body ball chamber with test liquid, so as to ensure that no seat leakage can escape detection. For trunnion-mounted valves of upstream sealing design, the test method shall be one that measures leakage across the upstream seat. For trunnion-mounted valves of downstream sealing design, the test method shall be one that measures leakage across the downstream seat.

8.1.3.3 The applicable closure test of [8.1.3.1](#) or [8.1.3.2](#) shall be applied, one flow direction at a time, for each seating direction.

8.1.3.4 The duration of the closure test, the minimum period of time that the test pressure is to be sustained for the purpose of obtaining a closure leakage measurement, shall be in accordance with [Table 7](#).

8.1.3.5 Over the duration of the closure test, the maximum permitted leakage rate past the seats shall be in accordance with [Table 8](#).

Table 8 — Maximum allowable seat leakage

Valve size range	Maximum allowable seat leakage rate		
	Gas test	Liquid test	
	Resilient seats ^a	Metal or ceramic seats ^b	
	—	mm ³ /s	drops/s
DN ≤ 50	0	6,0	0,1
65 ≤ DN ≤ 150	0	12,5	0,2
200 ≤ DN ≤ 300	0	20,8	0,4
350 ≤ DN ≤ 600	0	29,2	0,5

^a Refer to [8.1.3.7](#) regarding zero leakage rate.

^b The manufacturer may choose either method of quantifying liquid leakage. It is recognized that the unit conversions are inexact.

8.1.3.6 For resilient seats, visual evidence of leakage through the ball, behind the seats, or past shaft seals is not permitted. There shall be no structural damage as a result of the closure test. Plastic deformation of resilient seats or seals is not considered to be structural damage.

8.1.3.7 For the purposes of the gas closure test, zero leakage is defined as 3 mm³ (one bubble) over the duration of the test.

8.2 Inspection

Inspection by the purchaser may be specified in the purchase order. If not otherwise specified, inspection shall be limited to the following:

- inspection of the valve assembly to ensure compliance with the specifications of the purchase order, which may include specified non-destructive methods of examination;
- witnessing the required pressure tests and examinations;
- review of mill test reports and, if specified, non-destructive examination records and radiographs.

8.3 Examination

8.3.1 For each valve, the items listed in [Annex A](#) shall be checked by the manufacturer before release for shipment.

8.3.2 Castings of pressure boundary parts and the closure element (ball) shall be visually examined by the manufacturer during the course of manufacture. All cast surfaces shall be in conformance with the surface condition requirements of MSS-SP-55 except that all Type I defects are unacceptable and defects in excess of plate “a” and “b” for Type II through Type XII are unacceptable.

8.3.3 The valve manufacturer shall examine each valve to ensure compliance with this International Standard.

8.3.4 Examinations shall be performed in accordance with written procedures that are in accord with applicable standards.

8.4 Supplementary examination

8.4.1 Supplementary types of examination are required, only if specified in the purchase order.

8.4.2 Magnetic particle, radiographic, liquid penetrant and ultrasonic examination of castings or forgings may be specified as either the purchaser's own procedures and acceptance standards or those standardized in ASME B16.34:2013, Clause 8.

8.4.3 When service conditions require that a fire type-test be conducted, it is recommended that this test be in accordance with ISO 10497.

9 Preparation for despatch

9.1 After testing, each valve shall be drained and prepared for despatch. Special care shall be taken to drain test fluid from the body chamber surrounding the ball.

9.2 Except for austenitic stainless steel valves, unmachined exterior valve body surfaces shall have a rust preventative coating in accordance with the manufacturer's standard. Such coatings shall not contain lead.

9.3 Except for austenitic stainless steel valves, machined, or threaded surfaces that are not resistant to atmospheric corrosion shall be coated with an easily removed rust inhibitor. Such coatings shall not contain lead.

9.4 Protective covers of wood, wood fibre, plastic or metal shall be securely affixed to valve ends of flanged and butt-welding end valves in order to safeguard the gasket surfaces and weld end preparations. The cover design shall be such that the valve cannot be installed in a pipeline with the protective cover in place.

9.5 Protective end plugs of wood, wood fibre, plastic or metal shall be securely inserted into the valve ends of socket welding and threaded end valves. The protective plug design shall be such that the valve cannot be installed in a pipeline with the plug in place.

9.6 At the time of shipment, unless precluded by design or actuator fail action, the ball shall be in the fully open position.

9.7 When special packaging is necessary, the purchaser shall specify the requirements in the purchase order.

Annex A (informative)

Information to be specified by the purchaser

NOTE References between square brackets are to clauses or subclauses in this International Standard.

Nominal size [1] (DN or NPS)

Nominal pressure [1] (PN or Class)

Flow passageway [5.1] (full bore, reduced bore or double reduced bore)

Seat materials [4.3]

Body ends [5.2]

Threaded: (pipe threads ISO 7-1, ISO 228-1 or ASME B1.20.1) [5.2.5.2]

Flange facing: raised face, ring joint or other [5.2.2.1]

facing finish, if other than standard [5.2.2.4]

Butt-welding end details, if other than standard is needed [5.2.3.1]

Tapped openings required [5.2.6]

Anti-static feature [5.2.7]

Levers other than standard levers [5.2.11.1 and 5.2.11.7]

Gear actuators [5.2.11.2]

Material [6]

Pressure containing shell [6.1]

Trim, material other than standard [6.3]

Bolting, special for low temperature [6.5]

Seals, temperature rated [6.6]

Supplementary non-destructive examinations [8.4]

Supplementary fire type-test [8.4.3]

Preparation for shipment [9.7]

Annex B (informative)

Identification of valve parts

The purpose of [Figures B.1](#) and [B.2](#) is only to identify part names. The construction of a valve is acceptable according to this International Standard only when it complies with it in all respects.

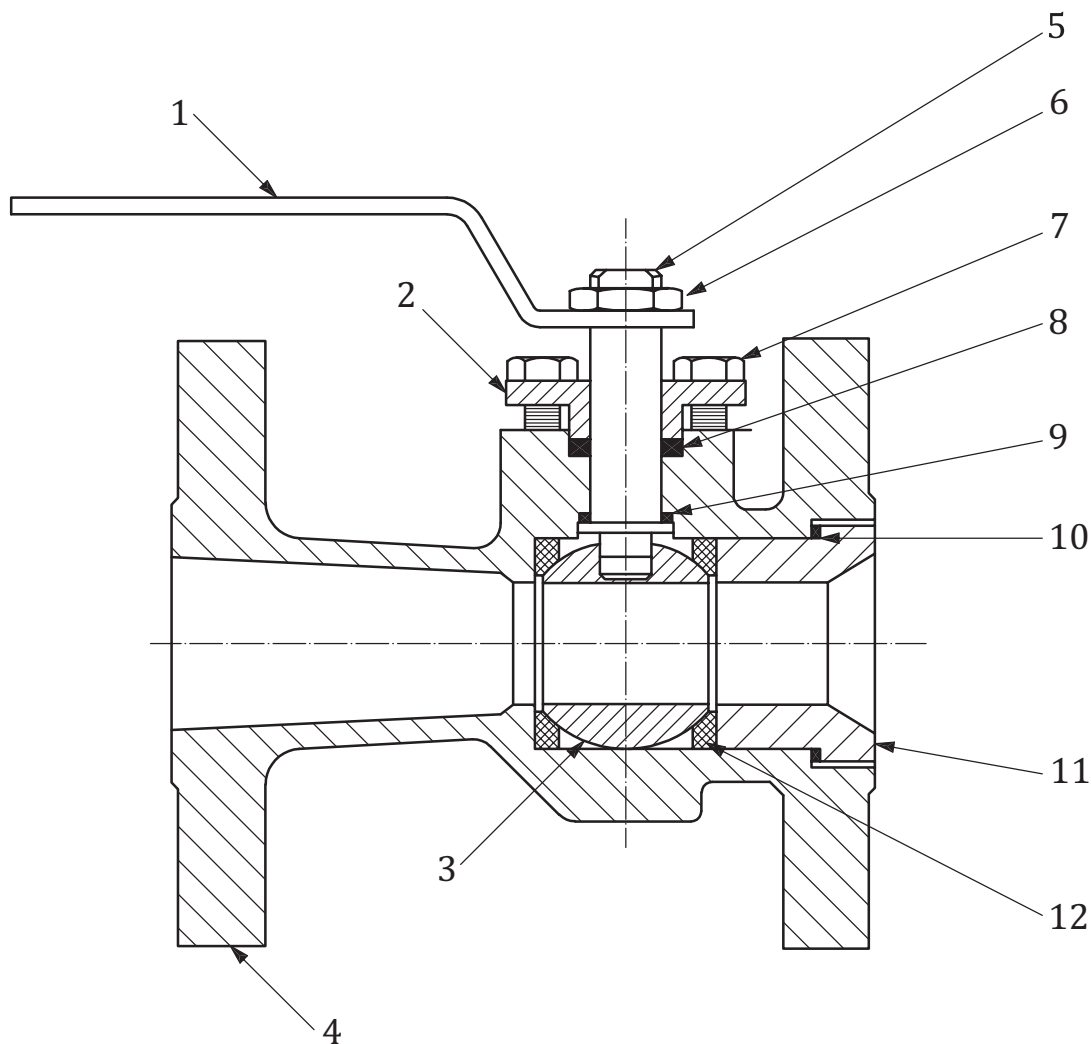

Key

- | | | | |
|---|---------------------|----|---------------|
| 1 | handle (lever type) | 7 | gland bolting |
| 2 | gland | 8 | stem seal |
| 3 | ball | 9 | thrust washer |
| 4 | body | 10 | body seal |
| 5 | stem | 11 | body insert |
| 6 | stem nut | 12 | seat |

Figure B.1 — Floating ball valve part names

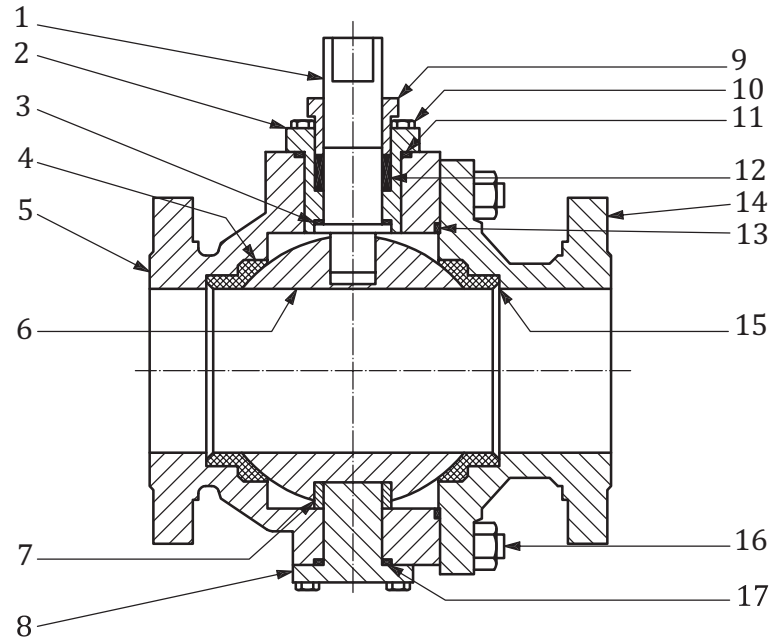

a) Example 1

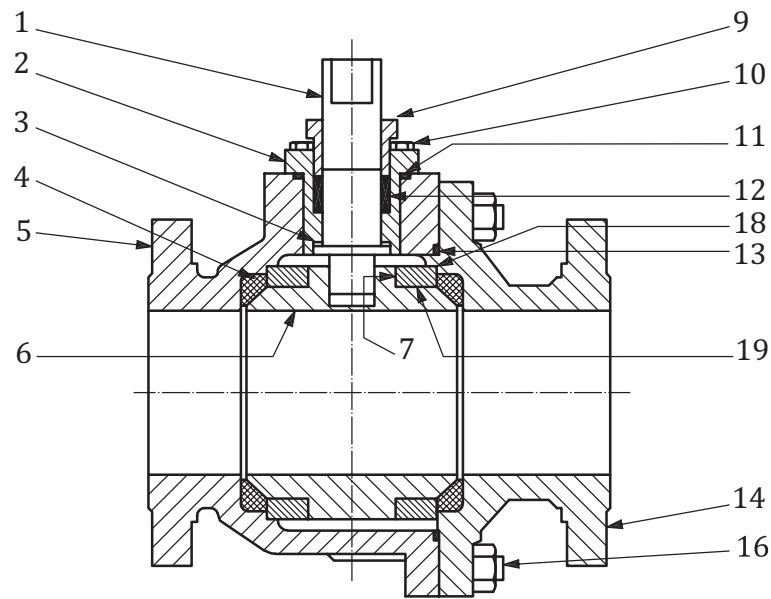

b) Example 2

Key

1	stem	8	trunnion pin/cap	15	seat spring
2	cover	9	gland	16	body bolting
3	thrust washer	10	cover bolting	17	trunnion seal
4	seat	11	cover seal	18	trunnion plate
5	body	12	stem seal	19	bearing spacer
6	ball	13	body seal		
7	trunnion bearing	14	body cap		

Figure B.2 — Trunnion-mounted ball valve part names

Bibliography

- [1] ISO 4200, *Plain end steel tubes, welded and seamless — General tables of dimensions and masses per unit length*
- [2] ISO 5211, *Industrial valves — Part-turn actuator attachments*
- [3] ISO 6708, *Pipework components — Definition and selection of DN (nominal size)*
- [4] ISO 7268, *Pipe components — Definition of nominal pressure*
- [5] ISO 10497, *Testing of valves — Fire type-testing requirements*
- [6] ISO 14313, *Petroleum and natural gas industries — Pipeline transportation systems — Pipeline valves*
- [7] ISO 17292, *Metal ball valves for petroleum, petrochemical and allied industries*
- [8] EN 1333, *Pipework components — Definition of PN*
- [9] EN 10269, *Steels and nickel alloys for fasteners with specified elevated and/or low temperature properties*
- [10] API 608, *Metal ball valves — Flanged, threaded and welding end*
- [11] ASME B16.11, *Forged fittings, socket-welding and threaded*
- [12] ASME B16.20, *Metallic gaskets for pipe flanges — Ring joint, spiral wound and jacketed*
- [13] ASME B16.25, *Buttwelding ends*
- [14] ASME B36.10, *Welded and seamless wrought steel pipe*
- [15] ASTM A307, *Standard specification for carbon steel bolts and studs, 60 000 PSI tensile strength*

British Standards Institution (BSI)

BSI is the national body responsible for preparing British Standards and other standards-related publications, information and services.

BSI is incorporated by Royal Charter. British Standards and other standardization products are published by BSI Standards Limited.

About us

We bring together business, industry, government, consumers, innovators and others to shape their combined experience and expertise into standards-based solutions.

The knowledge embodied in our standards has been carefully assembled in a dependable format and refined through our open consultation process. Organizations of all sizes and across all sectors choose standards to help them achieve their goals.

Information on standards

We can provide you with the knowledge that your organization needs to succeed. Find out more about British Standards by visiting our website at bsigroup.com/standards or contacting our Customer Services team or Knowledge Centre.

Buying standards

You can buy and download PDF versions of BSI publications, including British and adopted European and international standards, through our website at bsigroup.com/shop, where hard copies can also be purchased.

If you need international and foreign standards from other Standards Development Organizations, hard copies can be ordered from our Customer Services team.

Subscriptions

Our range of subscription services are designed to make using standards easier for you. For further information on our subscription products go to bsigroup.com/subscriptions.

With **British Standards Online (BSOL)** you'll have instant access to over 55,000 British and adopted European and international standards from your desktop. It's available 24/7 and is refreshed daily so you'll always be up to date.

You can keep in touch with standards developments and receive substantial discounts on the purchase price of standards, both in single copy and subscription format, by becoming a **BSI Subscribing Member**.

PLUS is an updating service exclusive to BSI Subscribing Members. You will automatically receive the latest hard copy of your standards when they're revised or replaced.

To find out more about becoming a BSI Subscribing Member and the benefits of membership, please visit bsigroup.com/shop.

With a **Multi-User Network Licence (MUNL)** you are able to host standards publications on your intranet. Licences can cover as few or as many users as you wish. With updates supplied as soon as they're available, you can be sure your documentation is current. For further information, email bsmusales@bsigroup.com.

Revisions

Our British Standards and other publications are updated by amendment or revision.

We continually improve the quality of our products and services to benefit your business. If you find an inaccuracy or ambiguity within a British Standard or other BSI publication please inform the Knowledge Centre.

Copyright

All the data, software and documentation set out in all British Standards and other BSI publications are the property of and copyrighted by BSI, or some person or entity that owns copyright in the information used (such as the international standardization bodies) and has formally licensed such information to BSI for commercial publication and use. Except as permitted under the Copyright, Designs and Patents Act 1988 no extract may be reproduced, stored in a retrieval system or transmitted in any form or by any means – electronic, photocopying, recording or otherwise – without prior written permission from BSI. Details and advice can be obtained from the Copyright & Licensing Department.

Useful Contacts:

Customer Services

Tel: +44 845 086 9001

Email (orders): orders@bsigroup.com

Email (enquiries): cservices@bsigroup.com

Subscriptions

Tel: +44 845 086 9001

Email: subscriptions@bsigroup.com

Knowledge Centre

Tel: +44 20 8996 7004

Email: knowledgecentre@bsigroup.com

Copyright & Licensing

Tel: +44 20 8996 7070

Email: copyright@bsigroup.com

BSI Group Headquarters

389 Chiswick High Road London W4 4AL UK

