

BS ISO 6932:2014



BSI Standards Publication

Cold-reduced carbon steel strip with a maximum carbon content of 0,25 %

bsi.

...making excellence a habit.™

National foreword

This British Standard is the UK implementation of ISO 6932:2014.

The UK participation in its preparation was entrusted to Technical Committee ISE/109, Coated and Uncoated Flat Products to be Used for Cold Forming.

A list of organizations represented on this committee can be obtained on request to its secretary.

This publication does not purport to include all the necessary provisions of a contract. Users are responsible for its correct application.

© The British Standards Institution 2014.
Published by BSI Standards Limited 2014

ISBN 978 0 580 82440 1

ICS 77.140.50

Compliance with a British Standard cannot confer immunity from legal obligations.

This British Standard was published under the authority of the Standards Policy and Strategy Committee on 31 May 2014.

Amendments/corrigenda issued since publication

Date	Text affected
------	---------------

INTERNATIONAL
STANDARD

ISO
6932

Fourth edition
2014-03-15

**Cold-reduced carbon steel strip with a
maximum carbon content of 0,25 %**

*Feuillards en acier au carbone laminés à froid avec une teneur
maximale en carbone égale à 0,25 %*



Reference number
ISO 6932:2014(E)



COPYRIGHT PROTECTED DOCUMENT

© ISO 2014

All rights reserved. Unless otherwise specified, no part of this publication may be reproduced or utilized otherwise in any form or by any means, electronic or mechanical, including photocopying, or posting on the internet or an intranet, without prior written permission. Permission can be requested from either ISO at the address below or ISO's member body in the country of the requester.

ISO copyright office
Case postale 56 • CH-1211 Geneva 20
Tel. + 41 22 749 01 11
Fax + 41 22 749 09 47
E-mail copyright@iso.org
Web www.iso.org

Published in Switzerland

Contents

	Page
Foreword	iv
1 Scope	1
2 Normative references	1
3 Terms and definitions	1
4 Dimensions	2
5 Chemical composition	2
5.1 General.....	2
5.2 Heat analysis.....	2
5.3 Product analysis.....	2
6 Conditions of manufacture	4
6.1 Physical properties.....	4
6.2 Steelmaking.....	4
6.3 Weldability.....	7
6.4 Application.....	7
6.5 Mechanical properties.....	7
6.6 Oiling.....	7
6.7 Edges.....	7
6.8 Surface finish.....	8
7 Dimensional and shape tolerances	8
8 Sampling — Hardness or tensile test	11
9 Mechanical property tests	11
9.1 Hardness test.....	11
9.2 Tensile test.....	11
10 Retests	12
10.1 Machining and flaws.....	12
10.2 Additional tests.....	12
11 Resubmission	12
12 Workmanship	12
13 Inspection and acceptance	12
14 Coil size	12
15 Marking	12
16 Information to be supplied by the purchaser	13
Bibliography	14

Foreword

ISO (the International Organization for Standardization) is a worldwide federation of national standards bodies (ISO member bodies). The work of preparing International Standards is normally carried out through ISO technical committees. Each member body interested in a subject for which a technical committee has been established has the right to be represented on that committee. International organizations, governmental and non-governmental, in liaison with ISO, also take part in the work. ISO collaborates closely with the International Electrotechnical Commission (IEC) on all matters of electrotechnical standardization.

The procedures used to develop this document and those intended for its further maintenance are described in the ISO/IEC Directives, Part 1. In particular the different approval criteria needed for the different types of ISO documents should be noted. This document was drafted in accordance with the editorial rules of the ISO/IEC Directives, Part 2 (see www.iso.org/directives).

Attention is drawn to the possibility that some of the elements of this document may be the subject of patent rights. ISO shall not be held responsible for identifying any or all such patent rights. Details of any patent rights identified during the development of the document will be in the Introduction and/or on the ISO list of patent declarations received (see www.iso.org/patents).

Any trade name used in this document is information given for the convenience of users and does not constitute an endorsement.

For an explanation on the meaning of ISO specific terms and expressions related to conformity assessment, as well as information about ISO's adherence to the WTO principles in the Technical Barriers to Trade (TBT) see the following URL: [Foreword - Supplementary information](#)

The committee responsible for this document is ISO/TC 17, *Steel*, Subcommittee SC 12, *Continuous mill flat rolled products*.

This fourth edition cancels and replaces the third edition (ISO 6932:2008), which has been technically revised.

Cold-reduced carbon steel strip with a maximum carbon content of 0,25 %

1 Scope

This International Standard describes cold-reduced carbon steel strip with a maximum mass fraction of carbon of 0,25 %, furnished to two levels of closer tolerances than cold-reduced carbon steel sheet, with specific quality, specific hardness requirements or mechanical properties, specific edge, and specific finish.

NOTE This International Standard does not apply to the product in narrow widths known as cold-reduced carbon steel sheet slit from wider widths (see ISO 3574), nor does it include cold-reduced carbon steel strip with a mass fraction of carbon over 0,25 % (see ISO 4960).

Cold-reduced carbon steel strip is produced with a maximum mass fraction of the specified carbon not exceeding:

- 0,15 % for material specified to mechanical properties;
- 0,25 % for material specified to temper (hardness) requirements.

2 Normative references

The following documents, in whole or in part, are normatively referenced in this document and are indispensable for its application. For dated references, only the edition cited applies. For undated references, the latest edition of the referenced document (including any amendments) applies.

ISO 6507-1, *Metallic materials — Vickers hardness test — Part 1: Test method*

ISO 6508-1, *Metallic materials — Rockwell hardness test — Part 1: Test method*

ISO 6892-1, *Metallic materials — Tensile testing — Part 1: Method of test at room temperature*

3 Terms and definitions

For the purposes of this document, the following terms and definitions apply.

3.1

cold-reduced carbon steel strip

product manufactured from hot-rolled, descaled coils by cold reducing to the desired thickness on a single-stand mill or on a tandem mill consisting of several single stands in series

3.2

cold reduction

process of reducing the thickness of the strip at room temperature whereby the amount of reduction is greater than that used for a *skin pass* ([3.8](#))

3.3

aluminium killed

steel which has been deoxidized with aluminium sufficient to prevent the evolution of gas during solidification

**3.4
annealing**

process of heating to, and holding at, a suitable temperature and then cooling at a suitable rate for such purposes as lowering hardness, facilitating cold working, producing a desired microstructure or obtaining desired mechanical, physical, or other properties

**3.5
temper**

designation by number or term to indicate the hardness as a minimum, as a maximum, or as a range

Note 1 to entry: The tempers are obtained by the selection and control of chemical composition by amounts of *cold reduction* (3.2), by thermal treatment, and by a skin pass.

**3.6
dead soft**

condition describing annealed strip produced without definite control of stretcher strains or fluting

Note 1 to entry: It is suitable for drawing and other applications where such surface characteristics are not objectionable.

**3.7
surface finish**

degree of smoothness or lustre of the strip

**3.8
skin pass**

light cold rolling of the product resulting in an increase in hardness and some loss in ductility

Note 1 to entry: The purpose of skin passing is to minimize the appearance of coil breaks, stretcher strains and fluting, or to control the shape, or to obtain the required *surface finish* (3.7).

**3.9
lot**
sample portion consisting of 50 t or less of strip of the same designation rolled to the same thickness and *temper* (3.5) or mechanical properties

4 Dimensions

This product is commonly produced in thicknesses of 6 mm and under, and in widths of up to 600 mm, in coils and cut lengths.

5 Chemical composition

5.1 General

The chemical composition (heat analysis) shall not exceed the values given in [Tables 1](#) and [2](#).

5.2 Heat analysis

An analysis of each heat of steel shall be made by the manufacturer to determine compliance with the requirements of [Tables 1](#) and [2](#). When requested at the time of ordering, this analysis shall be reported to the purchaser or his representative.

5.3 Product analysis

A product analysis can be made by the purchaser to verify the specified analysis of the product and shall take into consideration any normal heterogeneity.

The product analysis tolerances shall be in accordance with [Tables 2](#) and [3](#).

Table 1 — Chemical composition (heat analysis)

Mass fractions in per cent

Temper or quality designation	Carbon (C) max.	Manganese (Mn) max.	Phosphorus (P) max.	Sulfur (S) max.
Temper No. 1, 2, 3	0,25	0,60	0,035	0,04
Temper No. 4, 5	0,15	0,60	0,035	0,04
CR21	0,15	0,60	0,05	0,035
CR22	0,10	0,50	0,04	0,035
CR23	0,08	0,45	0,03	0,03
CR24	0,06	0,45	0,03	0,03

Table 2 — Limits on additional chemical elements^a

Mass fractions in per cent

Element	Heat analysis max.	Product analysis max.
Cu ^b	0,20	0,23
Ni ^b	0,20	0,23
Cr ^{b c}	0,15	0,19
Mo ^{b c}	0,06	0,07
Nb ^d	0,008	0,018
V ^d	0,008	0,018
Ti ^d	0,008	0,018

^a Each of the elements listed in this table shall be included in the report of the heat analysis. When the amount of copper, nickel, chromium, or molybdenum present is less than 0,02 %, the analysis can be reported as “<0,02 %”.

^b The sum of copper, nickel, chromium, and molybdenum shall not exceed 0,50 % on heat analysis. When one or more of these elements are specified, the sum does not apply; in which case, only the individual limits on the remaining elements will apply.

^c The sum of chromium and molybdenum shall not exceed 0,16 % on heat analysis. When one or more of these elements are specified, the sum does not apply; in which case, only the individual limits on the remaining elements will apply.

^d A heat analysis greater than 0,008 % can be supplied after agreement between producer and consumer.

Table 3 — Product analysis tolerances

Mass fractions in per cent

Element	Range of specified element	Tolerance over maximum specified
Carbon	≥0,06 to ≤0,15	0,03
	>0,15 to ≤0,25	0,04
Manganese	≤0,60	0,03
Phosphorus	≤0,05	0,01
Sulfur	≤0,04	0,01

NOTE The above maximum tolerance is the allowable excess over the specified requirements not the heat analysis.

6 Conditions of manufacture

6.1 Physical properties

6.1.1 Either temper requirements in accordance with [Table 4](#) or mechanical properties in accordance with [Table 5](#) can be specified as given in this International Standard, but not both, since there is no direct correlation.

6.1.2 Cold-reduced carbon steel strip specified to temper requirements is produced to the following temper designations:

- No. 1 (hard);
- No. 2 (half hard);
- No. 3 (quarter hard);
- No. 4 (skin-passed);
- No. 5 (dead soft).

6.1.3 Cold-reduced carbon steel strip specified to mechanical properties is produced to the following commercial and drawing quality designations:

- CR21 (commercial quality);
- CR22 (drawing quality);
- CR23 (deep drawing quality);
- CR24 (deep drawing quality aluminium killed).

6.2 Steelmaking

Unless otherwise agreed by the interested parties, the processes used in making the steel and in manufacturing cold-reduced carbon strip are left to the discretion of the manufacturer. On request, the purchaser shall be informed of the steelmaking process being used.

Table 4 — Temper and hardness requirements for cold-reduced carbon steel strip

Temper	Thickness <i>e</i> mm	Hardness			
		Rockwell B scale HRB	Rockwell 30T scale HR30T	Rockwell 15T scale HR15T	Vickers HV
No. 1 (hard)	$e \leq 0,36$	—	—	88,2 min.	170 min.
	$0,36 < e \leq 1,0$	—	73,1 min.	—	170 min.
	$e > 1,0$	84 min.	—	—	162 min.
No. 2 (half hard)	$e \leq 0,36$	—	—	83,5 to 89,5	125 to 185
	$0,36 < e \leq 1,0$	—	63,5 to 75,8	—	125 to 185
	$e > 1,0$	70 to 89	—	—	125 to 185
No. 3 (quarter hard)	$e \leq 0,36$	—	—	80 to 86,6	107 to 150
	$0,36 < e \leq 1,0$	—	56,5 to 69,7	—	107 to 150
	$e > 1,0$	60 to 80	—	—	107 to 150
No. 4 ^a (skin-passed)	$e \leq 0,36$	—	—	82 max.	116 max.
	$0,36 < e \leq 1,0$	—	60 max.	—	116 max.
	$e > 1,0$	65 max.	—	—	116 max.
No. 5 ^a (dead soft)	$e \leq 0,36$	—	—	78,5 max.	100 max.
	$0,36 < e \leq 1,0$	—	53 max.	—	100 max.
	$e > 1,0$	55 max.	—	—	100 max.

^a Can be ordered with a carbon range of 0,15 % to 0,25 %. In each instance, the maximum hardness requirement is established by agreement.

Table 5 — Mechanical property requirements for cold-reduced carbon steel strip^a

Quality designation	Condition of delivery ^b	R_e max. ^c MPa	R_m ^d MPa	A min. %	
				$L_0 = 80$ mm ^e	$L_0 = 50$ mm
CR21	HK ^f	—	—	—	—
	TC	—	410 max.	28	32
	HK270	—	410 max.	28	32
	HK290	—	290 to 430	18	24
	HK390	—	390 to 540	—	—
	HK490	—	490 to 640	—	—
	HK590	—	590 to 740	—	—
	HK690	—	690 min.	—	—
CR22	TC	—	370 max.	32	35
	HK270	250	370 max.	32	35
	HK290	355	290 to 410	21	25
	HK390	—	390 to 510	5	13
	HK490	—	490 to 620	—	—
	HK590	—	590 min.	—	—
CR23	TC	—	350 max.	36	38
	HK270	225 g	350 max.	36	38
	HK290	325	290 to 390	23	27
	HK390	—	390 to 490	6	14
	HK490	—	490 to 600	—	—
	HK590	—	590 min.	—	—
CR24	TC	—	350 max.	36	38
	HK270	225 g	350 max.	36	38
	HK290	325	290 to 390	23	27
	HK390	—	390 to 490	6	14
	HK490	—	490 to 590	—	—
	HK590	—	590 to 690	—	—

^a Longitudinal test pieces:

R_e yield strength;

R_m tensile strength;

A percentage elongation after fracture;

L_0 gauge length on test piece.

^b Conditions of delivery: HK, cold-reduced; TC, annealed; HK270, skin-passed; HK290 to HK690, cold-reduced, various amounts.

^c For thicknesses of 0,7 mm and less, the specified maximum yield strength values are increased by 20 MPa.

^d Minimum tensile strength values for delivery conditions HK, TC and HK270 would normally be expected to be 270 MPa.

^e Minimum elongation values are reduced by 2 % for thicknesses of 0,5 mm to 0,7 mm inclusive and by 4 % for thicknesses of less than 0,5 mm.

^f There are no mechanical property requirements for this condition.

^g For thicknesses of 1,5 mm and greater, the maximum yield strength is 235 MPa.

6.3 Weldability

This product is suitable for welding if appropriate welding conditions are selected. As carbon content increases above 0,15 %, spot welding becomes increasingly difficult.

6.4 Application

It is desirable that cold-reduced carbon steel strip be identified for fabrication by the name of the part or by intended application, which shall be compatible with the temper or mechanical properties specified. Proper identification of the part might include visual examination, prints or description, or a combination of these.

6.5 Mechanical properties

6.5.1 Hardness

When the temper designation is specified at the time the steel is made available for shipment, the hardness shall be as stated in [Table 4](#) when it is determined on test pieces obtained in accordance with the requirements of [Clause 7](#).

6.5.2 Tensile properties

When the mechanical property designation is specified at the time the steel is made available for shipment, the tensile properties shall be as stated in [Table 5](#) when they are determined on test pieces obtained in accordance with the requirements of [Clause 8](#).

6.6 Oiling

As a deterrent to rusting, a coating of oil is usually applied to the product. The oil is not intended as a drawing or forming lubricant and should be easily removable with degreasing chemicals. The product can be ordered not oiled, if required, in which case the supplier has limited responsibility if oxidation occurs.

6.7 Edges

The desired edge number shall be specified as follows:

- a) **No. 1 edge:** a prepared edge of specified contour (round or square) that is produced when a very accurate width is required or when an edge condition suitable for electroplating is required, or both;
- b) **No. 2 edge:** a natural mill edge carried through cold rolling from the hot-rolled carbon steel strip without additional processing of the edge;
- c) **No. 3 edge:** an approximately square edge, produced by slitting, on which the burr is not eliminated; normal coiling or piling does not necessarily provide a definite positioning of the slitting burr;
- d) **No. 4 edge:** a rounded edge produced by edge rolling either the natural edge of hot-rolled carbon steel strip or slit-edge material; this edge is produced when the width tolerances and edge condition are not as exacting as for the No. 1 edge;
- e) **No. 5 edge:** an approximately square edge produced from slit-edge material on which the burr is eliminated, usually by rolling or filing;
- f) **No. 6 edge:** a square edge produced by edge rolling the natural edge of hot-rolled carbon steel strip or slit-edge material; this edge is produced when the width tolerance and edge condition are not as exacting as for the No. 1 edge.

6.8 Surface finish

The finish is specified normally as one of the following:

- a) **No. 1 or matte (dull) finish:** a finish without lustre, produced by rolling on rolls toughened by mechanical, electrical, or chemical means; this finish is especially suitable for lacquer or paint adhesion, and is beneficial in aiding drawing operations by reducing the contact friction between the die and the strip;
- b) **No. 2 or regular bright finish:** a finish produced by rolling on rolls having a moderately smooth finish; it is suitable for many requirements, but not generally applicable to bright plating;
- c) **No. 3 or best bright finish:** a finish generally of high lustre, produced by selective rolling practices, including the use of specially prepared rolls; this is a high quality finish and is particularly suited for bright plating; the production of this finish requires extreme care in processing and extensive inspection;
- d) **No. 4 or mirror finish:** a finish of special high lustre, produced on specially polished rolls, mainly for highly decorative plating purposes; the production of this finish requires extreme care in processing and extensive inspection.

7 Dimensional and shape tolerances

Dimensional and shape tolerances applicable to cold-reduced carbon steel strip shall be as given in [Tables 6 to 11](#) inclusive. When required, special tolerances shall be as agreed between the manufacturer and the purchaser.

The tolerances on flatness for cut-to-length cold-reduced carbon steel strip shall be a maximum of 10 mm in any 1 000 mm of length. Any further requirements for flatness shall be agreed between the manufacturer and purchaser at the time of ordering. The tolerance on flatness is taken to be the greatest difference between the cut length resting on a plane horizontal base and a measuring rule laid in the direction of the longitudinal axis.

Table 6 — Thickness tolerances for cold-reduced carbon steel strip ordered to nominal thickness — Coils and cut lengths

Values in millimetres

Specified thickness <i>E</i>	Tolerance ^a					
	<i>b</i> ≤ 125		125 < <i>b</i> ≤ 250		250 < <i>b</i> ≤ 600	
	N	R	N	R	N	R
≤ 0,15	±0,01	±0,01	±0,02	±0,015	—	—
0,15 < <i>e</i> ≤ 0,25	±0,02	±0,015	±0,02	±0,015	—	—
0,25 < <i>e</i> ≤ 0,40	±0,02	±0,015	±0,03	±0,02	±0,03	±0,02
0,40 < <i>e</i> ≤ 0,60	±0,03	±0,02	±0,03	±0,02	±0,04	±0,03
0,60 < <i>e</i> ≤ 0,80	±0,04	±0,03	±0,04	±0,03	±0,05	±0,035
0,80 < <i>e</i> ≤ 1,00	±0,04	±0,03	±0,05	±0,035	±0,05	±0,035
1,00 < <i>e</i> ≤ 1,50	±0,05	±0,035	±0,06	±0,045	±0,07	±0,055
1,50 < <i>e</i> ≤ 2,50	±0,06	±0,04	±0,07	±0,055	±0,08	±0,06

^a *b* indicates the specified width; N indicates normal tolerances; R indicates restrictive tolerances.

NOTE Thickness is measured at any point on the strip not less than 20 mm from a side edge for mill edge strip and not less than 10 mm from a side edge for sheared edge strip. For widths of mill edge strip 40 mm wide or less and sheared edge strip 20 mm wide or less, measurements are made on the centre-line of the strip. Measurement shall not be made on top of the shear burr.

Table 6 (continued)

Specified thickness <i>E</i>	Tolerance ^a					
	<i>b</i> ≤ 125		125 < <i>b</i> ≤ 250		250 < <i>b</i> ≤ 600	
	N	R	N	R	N	R
2,50 < <i>e</i> ≤ 4,00	±0,07	±0,05	±0,08	±0,06	±0,10	±0,08
4,00 < <i>e</i> ≤ 6,00	±0,09	±0,06	±0,10	±0,08	±0,12	±0,09

^a *b* indicates the specified width; N indicates normal tolerances; R indicates restrictive tolerances.

NOTE Thickness is measured at any point on the strip not less than 20 mm from a side edge for mill edge strip and not less than 10 mm from a side edge for sheared edge strip. For widths of mill edge strip 40 mm wide or less and sheared edge strip 20 mm wide or less, measurements are made on the centre-line of the strip. Measurement shall not be made on top of the shear burr.

Table 7 — Width tolerances for edges No. 1, 4, 5, and 6 for cold-reduced carbon steel strip

Values in millimetres

Edge No.	Specified width <i>b</i>	Specified thickness		Width tolerance
		min.	max.	
1	<i>b</i> ≤ 200	—	3,0	±0,13
4	<i>b</i> ≤ 25	0,6	5,0	±0,38
	25 < <i>b</i> ≤ 50	0,6	6,0	±0,65
	50 < <i>b</i> ≤ 150	1,0	6,0	±1,20
5	<i>b</i> ≤ 100	—	3,0	±0,13
	100 < <i>b</i> ≤ 500	0,4	3,0	±0,25
	500 < <i>b</i> ≤ 600	0,6	2,0	±0,38
6	<i>b</i> ≤ 25	0,6	5,0	±0,38
	25 < <i>b</i> ≤ 50	0,6	6,0	±0,65
	50 < <i>b</i> ≤ 150	1,0	6,0	±1,20

Table 8 — Width tolerance for edge No. 2 (mill) for cold-reduced carbon steel strip

Values in millimetres

Specified width <i>b</i>	Width tolerance ^a
<i>b</i> ≤ 100	±1,5
100 < <i>b</i> ≤ 200	±2,0
200 < <i>b</i> ≤ 400	±2,5
400 < <i>b</i> ≤ 500	±3,0
500 < <i>b</i> ≤ 600	±4,0

^a The values specified do not apply to the uncropped ends of a mill edge coil within 7 m inclusive of either end.

Table 9 — Width tolerances for edge No. 3 (slit) for cold-reduced carbon steel strip

Values in millimetres

Specified width <i>b</i>	Width tolerance for specified thickness <i>e</i>			
	$e \leq 1,5$	$1,5 < e \leq 2,5$	$2,5 < e \leq 4,5$	$4,5 < e \leq 6,0$
$b \leq 100$	±0,20	±0,25	±0,35	±0,40
$100 < b \leq 200$	±0,25	±0,30	±0,45	±0,50
$200 < b \leq 300$	±0,30	±0,35	±0,50	±0,50
$300 < b \leq 450$	±0,40	±0,45	±0,60	±0,70
$450 < b \leq 600$	±0,50	±0,50	±0,60	±0,70

Table 10 — Length tolerances for cold-reduced carbon steel strip

Values in millimetres

Specified width <i>b</i>	Tolerance for specified length <i>l</i>		
	$600 \leq l \leq 1\,500$	$1\,500 < l \leq 3\,000$	$l > 3\,000$
$b \leq 300$	+10 0	+15 0	+20 0
$300 < b \leq 600$	+15 0	+20 0	+25 0

Table 11 — Camber^a tolerances for cold-reduced carbon steel strip, for coils and cut lengths, applicable to all types of edges

Values in millimetres

Width <i>b</i>	Camber tolerance ^b
$10 < b \leq 40$	25 max. in any 2 000 mm length
$40 < b \leq 600$	10 max. in any 2 000 mm length

^a Camber is the greatest deviation of a side edge from a straight line, the measurement being taken on the concave side with a straight-edge, as shown in [Figure 1](#).

^b The values do not apply to the uncropped ends of a mill edge coil within 7 m inclusive of either end.

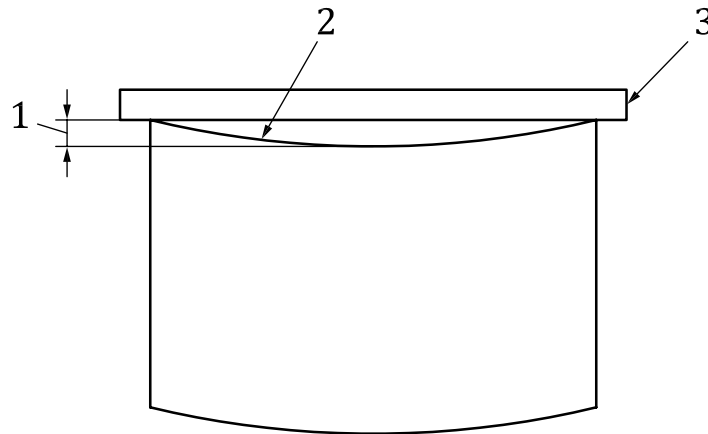

Key

- 1 edge camber
- 2 side edge (concave side)
- 3 straight-edge

Figure 1 — Measurement of camber

NOTE In those cases where it is not practicable to measure the tolerance as given in [Table 11](#), the camber tolerance, t_2 , can be calculated from Formula (1):

$$t_2 = (l_2/l_1)^2 \times t_1 \quad (1)$$

where

- l_1 is the standard length in [Table 11](#) (2 000 mm);
- l_2 is the non-standard length;
- t_1 is the camber tolerance in [Table 11](#).

8 Sampling — Hardness or tensile test

One representative sample for the hardness test ([Table 4](#)) or tensile test ([Table 5](#)) shall be taken from each lot of strip for shipment.

9 Mechanical property tests

9.1 Hardness test

The hardness test shall be carried out in accordance with ISO 6507-1 or ISO 6508-1, as applicable.

9.2 Tensile test

The tensile test shall be carried out in accordance with ISO 6892-1.

10 Retests

10.1 Machining and flaws

If any test piece shows defective machining or develops flaws, it shall be discarded and another test piece substituted.

10.2 Additional tests

If a test does not give the specified results, two additional tests shall be carried out on the same lot. Both retests shall conform to the requirements of this International Standard; otherwise, the lot shall be rejected.

11 Resubmission

The manufacturer can resubmit for acceptance the products that have been rejected during earlier inspection because of unsatisfactory properties, after he has subjected them to a suitable treatment (for example: selection, heat treatment), which, on request, will be indicated to the purchaser. In this case, tests shall be carried out as if they applied to a new batch.

The manufacturer has the right to present the rejected products to a new examination for compliance with the requirements for another temper, quality designation, edge or finish.

12 Workmanship

The surface condition shall be that normally obtained in this product, as specified in [6.8](#).

The material in cut lengths shall be free from any lamination, surface flaws and other imperfections that are detrimental to the final product or to subsequent appropriate processing.

Processing for shipment in coils does not afford the manufacturer the opportunity to readily observe or to remove imperfect portions, as can be carried out on the cut length product.

13 Inspection and acceptance

While not usually required for products covered by this International Standard, when the purchaser specifies that inspection and tests for acceptance be observed prior to shipment from the manufacturer's works, the manufacturer shall afford the purchaser's inspector all reasonable facilities to determine that the steel is being furnished in accordance with this International Standard.

Steel that is reported to be defective after arrival at the user's works shall be set aside properly, correctly identified, and adequately protected. The supplier shall be notified in order that he can properly investigate.

14 Coil size

When the product is ordered in coils, a minimum inside diameter (ID) or range of acceptable inside diameters shall be specified. In addition, the maximum outside diameter (OD) and the maximum acceptable coil mass shall be specified.

15 Marking

Unless otherwise stated, the following minimum requirements for identifying the steel shall be legibly stencilled on the top of each lift or shown on a tag attached to each coil or shipping unit:

- a) manufacturer's name or identifying brand;

- b) reference to this International Standard, i.e. ISO 6932;
- c) quality designation or temper;
- d) type of edge;
- e) type of finish;
- f) order number;
- g) product dimensions;
- h) lot number;
- i) mass.

16 Information to be supplied by the purchaser

To specify adequately the requirements of this International Standard, enquiries and orders shall include the following information:

- a) reference to this International Standard, i.e. ISO 6932;
- b) name, quality and temper or mechanical property designation (see [6.1](#) and [Tables 4](#) and [5](#));
- c) type of edge (see [6.7](#));
- d) type of finish (see [6.8](#));
- e) dimensions of the product and quantity required;
- f) application (name of part), if possible (see [6.4](#));
- g) a report of the heat analysis, if required (see [5.2](#));
- h) limitations on mass and dimensions of individual coils or bundles, if applicable (see [Clause 14](#));
- i) inspection and tests, if any, required for acceptance prior to shipment from the manufacturer's works (see [Clause 13](#));
- j) steelmaking process (see [6.2](#));
- k) N or R tolerances (see [Table 6](#)).

NOTE Typical ordering descriptions are given in Examples 1 and 2 below.

EXAMPLE 1 ISO 6932:2014 cold-reduced carbon steel strip, CR21 TC, No. 3 edge, No. 1 finish, 1,30 mm × 66,5 mm × 1 500 mm, 10 000 kg, to be used for cruise control field plate, oiled, maximum bundle mass 250 kg, maximum lift mass 1 000 kg, N thickness tolerance.

EXAMPLE 2 ISO 6932:2014 cold-reduced carbon steel strip, aluminium killed, No. 4 temper, No. 3 edge, No. 1 finish, 1,90 mm × 92 mm × coil, 6 000 kg, to be used for hinge strap, coils 400 mm minimum ID 1 500 mm maximum OD, maximum lift mass 1 200 kg, R thickness tolerance.

Bibliography

- [1] ISO 3574, *Cold-reduced carbon steel sheet of commercial and drawing qualities*
- [2] ISO 4960, *Cold-reduced carbon steel strip with a mass fraction of carbon over 0,25 %*
- [3] ASTM A109/A109M,¹⁾*Standard Specification for Steel Strip, Carbon (0.25 Maximum Percent), Cold-Rolled*
- [4] JIS G3141, *Cold-reduced carbon steel sheets and strips*
- [5] IS 513, *Cold-rolled low carbon steel sheets and strips*

1) This document is recognized by ISO/TC17/SC12 to cover a subject similar to that of this International Standard. This information is given for the convenience of users of this International Standard and constitutes neither an endorsement of the document by TC17/SC12 or ISO, nor a statement regarding its degree of equivalence with this International Standard.

British Standards Institution (BSI)

BSI is the national body responsible for preparing British Standards and other standards-related publications, information and services.

BSI is incorporated by Royal Charter. British Standards and other standardization products are published by BSI Standards Limited.

About us

We bring together business, industry, government, consumers, innovators and others to shape their combined experience and expertise into standards-based solutions.

The knowledge embodied in our standards has been carefully assembled in a dependable format and refined through our open consultation process. Organizations of all sizes and across all sectors choose standards to help them achieve their goals.

Information on standards

We can provide you with the knowledge that your organization needs to succeed. Find out more about British Standards by visiting our website at bsigroup.com/standards or contacting our Customer Services team or Knowledge Centre.

Buying standards

You can buy and download PDF versions of BSI publications, including British and adopted European and international standards, through our website at bsigroup.com/shop, where hard copies can also be purchased.

If you need international and foreign standards from other Standards Development Organizations, hard copies can be ordered from our Customer Services team.

Subscriptions

Our range of subscription services are designed to make using standards easier for you. For further information on our subscription products go to bsigroup.com/subscriptions.

With **British Standards Online (BSOL)** you'll have instant access to over 55,000 British and adopted European and international standards from your desktop. It's available 24/7 and is refreshed daily so you'll always be up to date.

You can keep in touch with standards developments and receive substantial discounts on the purchase price of standards, both in single copy and subscription format, by becoming a **BSI Subscribing Member**.

PLUS is an updating service exclusive to BSI Subscribing Members. You will automatically receive the latest hard copy of your standards when they're revised or replaced.

To find out more about becoming a BSI Subscribing Member and the benefits of membership, please visit bsigroup.com/shop.

With a **Multi-User Network Licence (MUNL)** you are able to host standards publications on your intranet. Licences can cover as few or as many users as you wish. With updates supplied as soon as they're available, you can be sure your documentation is current. For further information, email bsmusales@bsigroup.com.

BSI Group Headquarters

389 Chiswick High Road London W4 4AL UK

Revisions

Our British Standards and other publications are updated by amendment or revision.

We continually improve the quality of our products and services to benefit your business. If you find an inaccuracy or ambiguity within a British Standard or other BSI publication please inform the Knowledge Centre.

Copyright

All the data, software and documentation set out in all British Standards and other BSI publications are the property of and copyrighted by BSI, or some person or entity that owns copyright in the information used (such as the international standardization bodies) and has formally licensed such information to BSI for commercial publication and use. Except as permitted under the Copyright, Designs and Patents Act 1988 no extract may be reproduced, stored in a retrieval system or transmitted in any form or by any means – electronic, photocopying, recording or otherwise – without prior written permission from BSI. Details and advice can be obtained from the Copyright & Licensing Department.

Useful Contacts:

Customer Services

Tel: +44 845 086 9001

Email (orders): orders@bsigroup.com

Email (enquiries): cservices@bsigroup.com

Subscriptions

Tel: +44 845 086 9001

Email: subscriptions@bsigroup.com

Knowledge Centre

Tel: +44 20 8996 7004

Email: knowledgecentre@bsigroup.com

Copyright & Licensing

Tel: +44 20 8996 7070

Email: copyright@bsigroup.com



...making excellence a habit.™