

BS ISO 6358-2:2013



BSI Standards Publication

Pneumatic fluid power — Determination of flow-rate characteristics of components using compressible fluids

Part 2: Alternative test methods

bsi.

...making excellence a habit.™

National foreword

This British Standard is the UK implementation of ISO 6358-2:2013. Together with BS ISO 6358-1:2013 and BS ISO 6358-3, it supersedes BS 7294:1990 (dual numbered as ISO 6358:1989), which will be withdrawn on publication of Part 3.

The UK participation in its preparation was entrusted by Technical Committee MCE/18, Fluid power systems and components, to Subcommittee MCE/18/-/5, Control components.

A list of organizations represented on this subcommittee can be obtained on request to its secretary.

This publication does not purport to include all the necessary provisions of a contract. Users are responsible for its correct application.

© The British Standards Institution 2013.
Published by BSI Standards Limited 2013

ISBN 978 0 580 61665 5

ICS 23.100.01

Compliance with a British Standard cannot confer immunity from legal obligations.

This British Standard was published under the authority of the Standards Policy and Strategy Committee on 30 November 2013.

Amendments/corrigenda issued since publication

Date	Text affected
------	---------------

**Pneumatic fluid power —
Determination of flow-rate
characteristics of components using
compressible fluids —**

**Part 2:
Alternative test methods**

*Transmissions pneumatiques — Détermination des caractéristiques
de débit des composants traversés par un fluide compressible —*

Partie 2: Méthodes d'essai alternatives





COPYRIGHT PROTECTED DOCUMENT

© ISO 2013

All rights reserved. Unless otherwise specified, no part of this publication may be reproduced or utilized otherwise in any form or by any means, electronic or mechanical, including photocopying, or posting on the internet or an intranet, without prior written permission. Permission can be requested from either ISO at the address below or ISO's member body in the country of the requester.

ISO copyright office
Case postale 56 • CH-1211 Geneva 20
Tel. + 41 22 749 01 11
Fax + 41 22 749 09 47
E-mail copyright@iso.org
Web www.iso.org

Published in Switzerland

Contents

	Page
Foreword	iv
Introduction	v
1 Scope	1
2 Normative references	2
3 Terms and definitions	2
4 Symbols and units	2
5 Test installation	2
5.1 Test circuit for discharge test.....	3
5.2 Test circuit for charge test.....	3
5.3 General requirements.....	4
5.4 Requirements for the tank (item 4).....	5
5.5 Special requirements.....	7
6 Test procedures	8
6.1 Test conditions.....	8
6.2 Measuring procedures.....	9
6.3 Calculation of characteristics.....	12
7 Presentation of test results	16
8 Identification statement (reference to this part of ISO 6358).....	17
Annex A (informative) Evaluation of measurement uncertainty	18
Annex B (normative) Test method to determine and calibrate the volume of an isothermal tank	24
Annex C (informative) Isothermal tank stuffing	30
Annex D (informative) Test method to determine isothermal performance	33
Annex E (informative) Equations for calculation of flow-rate characteristics	36
Annex F (informative) Procedures for calculating critical back-pressure ratio, b, and subsonic index, m, by the least-square method using the Solver function in Microsoft Excel	39
Bibliography	43

Foreword

ISO (the International Organization for Standardization) is a worldwide federation of national standards bodies (ISO member bodies). The work of preparing International Standards is normally carried out through ISO technical committees. Each member body interested in a subject for which a technical committee has been established has the right to be represented on that committee. International organizations, governmental and non-governmental, in liaison with ISO, also take part in the work. ISO collaborates closely with the International Electrotechnical Commission (IEC) on all matters of electrotechnical standardization.

International Standards are drafted in accordance with the rules given in the ISO/IEC Directives, Part 2.

The main task of technical committees is to prepare International Standards. Draft International Standards adopted by the technical committees are circulated to the member bodies for voting. Publication as an International Standard requires approval by at least 75 % of the member bodies casting a vote.

Attention is drawn to the possibility that some of the elements of this document may be the subject of patent rights. ISO shall not be held responsible for identifying any or all such patent rights.

ISO 6358-2 was prepared by Technical Committee ISO/TC 131, *Fluid power systems*, Subcommittee SC 5, *Control products and components*.

This first edition of ISO 6358-2, together with ISO 6358-1 and ISO 6358-3, cancels and replaces ISO 6358:1989, which has been technically revised. However, ISO 6358-2 and ISO 6358-3 are new standards whose scopes were not included in ISO 6358:1989.

ISO 6358 consists of the following parts, under the general title *Pneumatic fluid power — Determination of flow-rate characteristics of components using compressible fluids*:

- *Part 1: General rules and test methods for steady-state flow*
- *Part 2: Alternative test methods*
- *Part 3: Method for calculating steady-state flow-rate characteristics of assemblies*

Introduction

In pneumatic fluid power systems, power is transmitted and controlled through a gas under pressure within a circuit. Components that make up such a circuit are inherently resistive to the flow of the gas and it is necessary, therefore, to define and determine the flow-rate characteristics that describe their performance.

ISO 6358:1989 was developed to determine the flow-rate characteristics of pneumatic valves, based upon a model of converging nozzles. The method included two characteristic parameters: sonic conductance, C , and critical pressure ratio, b , used in a proposed mathematical approximation of the flow behaviour. The result described flow performance of a pneumatic valve from choked flow to subsonic flow, based on static pressure. This new edition uses stagnation pressure instead, to take into account the influence of flow velocity on the measurement of pressures.

Experience has demonstrated that many pneumatic valves have converging–diverging characteristics that do not fit the ISO 6358:1989 model very well. Furthermore, new developments have allowed the application of this method to additional components beyond pneumatic valves. However, this now requires the use of four parameters (C , b , m , and Δp_c) to define the flow performance in both the choked and subsonic flow regions.

This part of ISO 6358 describes a set of three flow-rate characteristic parameters determined from test results. These parameters are described as follows and are listed in decreasing order of priority:

- The sonic conductance, C , corresponding to the maximum flow rate (choked) is the most important parameter. This parameter is defined by the upstream stagnation conditions.
- The critical back-pressure ratio, b , representing the boundary between choked and subsonic flow is second in importance. Its definition differs here from the one in ISO 6358:1989 because it corresponds to the ratio of downstream to upstream stagnation pressures.
- The subsonic index, m , is used if necessary to represent more accurately the subsonic flow behaviour. For components with a fixed flow path, m is distributed around 0,5. In these cases, only the first two characteristic parameters C and b are necessary. For many other components, m will vary widely. In these cases, it is necessary to determine C , b , and m .

Several changes to the test equipment were made to overcome apparent violations of the theory of compressible fluid flow. This included expanded inlet pressure-measuring tubes to satisfy the assumptions of negligible inlet velocity to the item under test and to allow the inlet stagnation pressure to be measured directly. Expanded outlet tubes allow the direct measurement of downstream stagnation pressure to better accommodate the different component models. The difference between stagnation pressure at upstream and downstream of component means a loss of pressure energy.

ISO 6358-3 can be used to calculate without measurements an estimate of the overall flow-rate characteristics of an assembly of components and piping, using the characteristics of each component and piping determined in accordance with this part of ISO 6358 or ISO 6358-1.

The discharge and charge test methods specified in this part of ISO 6358 have the following advantages over the test method specified in ISO 6358-1:

- a) an air source with a large flow-rate capacity is not required;
- b) components with larger flow-rate capacity can be tested more easily;
- c) energy consumption is minimised; and
- d) test time is shortened in the discharge test, and noise level is decreased in the charge test.

It should be noted that performance characteristics measured in accordance with this edition of ISO 6358 will differ from those measured in accordance with ISO 6358:1989.

Pneumatic fluid power — Determination of flow-rate characteristics of components using compressible fluids —

Part 2: Alternative test methods

1 Scope

This part of ISO 6358 specifies a discharge test and a charge test as alternative methods for testing pneumatic fluid power components that use compressible fluids, i.e. gases, and that have internal flow passages that can be either fixed or variable in size to determine their flow-rate characteristics. However, this part of ISO 6358 does not apply to components whose flow coefficient is unstable during use, i.e. components that exhibit remarkable hysteretic behaviour (because they can contain flexible parts that deform under the flow) or that have an internal feedback phenomenon (such as regulators), or components that have a cracking pressure such as non-return (check) valves and quick-exhaust valves. In addition, it does not apply to components that exchange energy with the fluid during flow-rate measurement, e.g. cylinders, accumulators, etc.

NOTE This part of ISO 6358 does not provide a method to determine if a component has hysteretic behaviour; ISO 6358-1 does provide such a method.

[Table 1](#) provides a summary of which parts of ISO 6358 can be applied to various components.

Table 1 — Application of ISO 6358 test methods to components

Components		Constant upstream pressure test		Variable upstream pressure test	
		ISO 6358-1 constant upstream pressure test	ISO 6358-2 charge test	ISO 6358-1 variable upstream pressure test	ISO 6358-2 discharge test
Group 1	Directional control valves	yes	yes	yes	yes
	Flow control valves	yes	yes	yes	yes
	Connectors	yes	yes	yes	yes
	Valve manifolds	yes	yes	yes	yes
	Group of components	yes	yes	yes	yes
Group 2	Filters and lubricators	yes	no	no	no
	Non-return (check) valves	yes	no	no	no
	Tubes and hoses	yes	no	no	no
Group 3	Silencers and exhaust oil mist separators	no	no	yes	yes
	Blow nozzles	no	no	yes	yes
	Quick-exhaust valves	no	no	yes	yes
	Cylinder end heads	no	no	yes	yes

The charge test cannot be performed on components that do not have downstream port connections.

This part of ISO 6358 specifies requirements for the test installation, the test procedure, and the presentation of results.

Evaluation of measurement uncertainties is described in [Annex A](#). Requirements for a method to test the volume of an isothermal tank are given in [Annex B](#). Guidance on the isothermal tank is given in [Annex C](#). Requirements for a method to test isothermal performance are given in [Annex D](#). Guidance on the equation for calculating characteristics is given in [Annex E](#). Guidance on calculating flow-rate characteristics is given in [Annex F](#).

2 Normative references

The following documents, in whole or in part, are normatively referenced in this document and are indispensable for its application. For dated references, only the edition cited applies. For undated references, the latest edition of the referenced document (including any amendments) applies.

ISO 1219-1, *Fluid power systems and components — Graphical symbols and circuit diagrams — Part 1: Graphical symbols for conventional use and data-processing applications*

ISO 5598, *Fluid power systems and components — Vocabulary*

ISO 6358-1, *Pneumatic fluid power — Determination of flow-rate characteristics of components using compressible fluids — Part 1: General rules and test methods for steady-state flow*

3 Terms and definitions

For the purposes of this document, the terms and definitions in ISO 5598 and ISO 6358-1 apply.

4 Symbols and units

4.1 The symbols and units shall be in accordance with ISO 6358-1 and [Table 2](#).

Table 2 — Symbols and units

Reference	Description	Symbol	Dimension ^a	SI units	Practical units
5.5.2	Time	<i>t</i>	T	s	s
5.4.3	Tank volume	<i>V</i>	L ³	m ³	dm ³

^a T = time; L = length

4.2 The numerals used as subscripts to the symbols shall be in accordance with ISO 6358-1 and [Table 3](#).

Table 3 — Subscripts

Subscript	Meaning
3	Tank conditions

4.3 The graphic symbols used in [Figures 1](#) and [2](#) are in accordance with ISO 1219-1.

5 Test installation

CAUTION — [Figures 1](#) and [2](#) illustrate basic circuits that do not incorporate all the safety devices necessary to protect against damage in the event of component failure. It is important that those responsible for carrying out the test give due consideration to safeguarding both personnel and equipment.

5.1 Test circuit for discharge test

A suitable test circuit as shown in [Figure 1](#) shall be used for the discharge test. See [5.3.5](#).

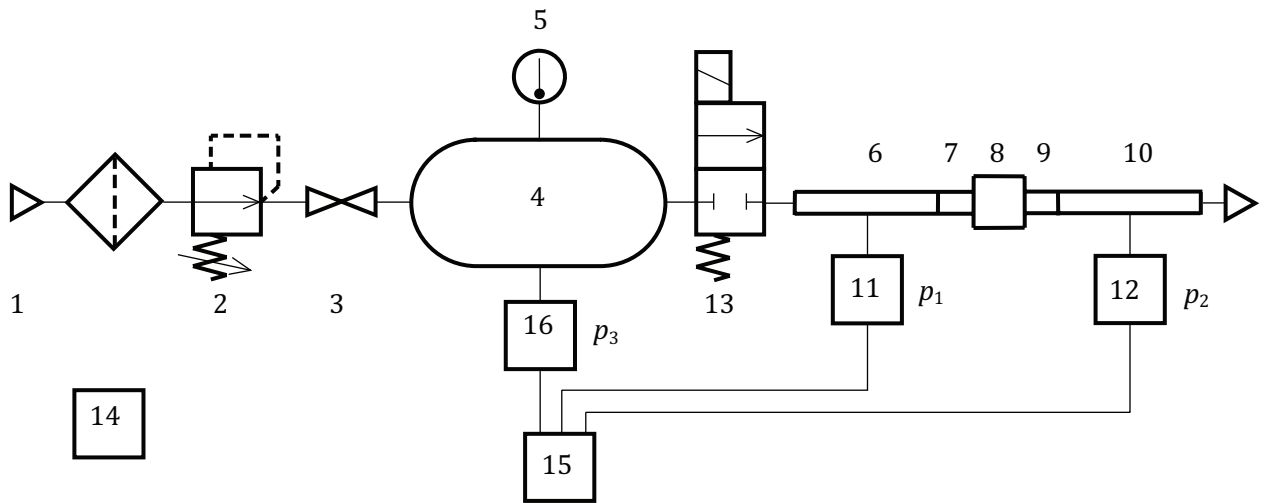

NOTE See [Table 4](#) for the key to test circuit components.

Figure 1 — Test circuit for discharge test

5.2 Test circuit for charge test

A suitable test circuit as shown in [Figure 2](#) shall be used for the charge test.

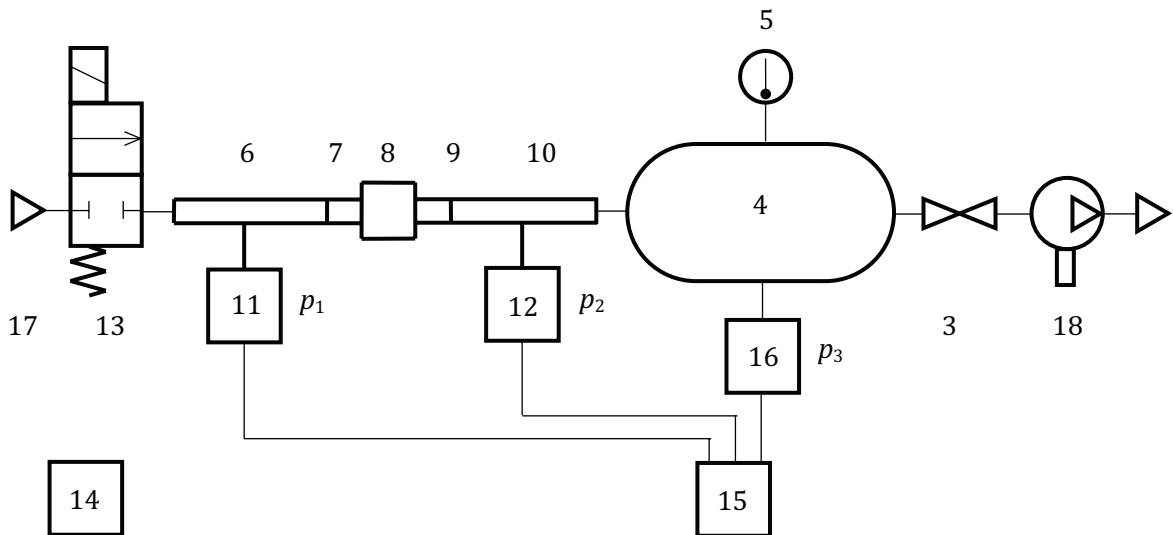

NOTE See [Table 4](#) for the key to test circuit components.

Figure 2 — Test circuit for charge test

Table 4 — Key to test circuit components shown in [Figures 1](#) and [2](#)

Key item number	Relevant subclause or paragraph	Description	Additional requirements
1	5.3.2	Compressed gas source and filter for discharge test	
2	-	Adjustable pressure regulator for discharge test	
3	-	Shut-off valve	
4	5.4	Tank	
5	-	Temperature-measuring instrument	
6	5.3.7	Upstream pressure-measuring tube	
7	5.3.7	Upstream transition connector	
8	-	Component under test	
9	5.3.7	Downstream transition connector	
10	5.3.7	Downstream pressure-measuring tube	
11	5.3.10	Pressure transducer	
12	5.3.10	Pressure transducer	
13	5.3.4 and 5.3.9	Flow control solenoid valve (optional)	The sonic conductance of this flow control valve shall be about four times larger than that of the component under test.
14	-	Barometer	
15	-	Digital recorder	
16	5.3.10	Pressure transducer	
17	-	Suction port for charge test	
18	-	Vacuum pump for charge test	

5.3 General requirements

5.3.1 The component under test shall be installed and operated in the test circuit in accordance with the manufacturer's operating instructions.

5.3.2 For the discharge test, a filter shall be installed which provides a standard of filtration specified by the manufacturer of the component under test.

5.3.3 A test set-up shall be constructed from the items listed in [Table 4](#). Items 1 through 8, 11, and 14 through 16 are required for the discharge test. Items 3 through 12 and 14 through 18 are required for the charge test.

5.3.4 If the component under test has no control mechanism for shifting its position, install a flow control solenoid valve (item 13) upstream of pressure-measuring tube (item 6) in order to start the test.

5.3.5 Items 9, 10, and 12 are not required for the discharge test when the component under test does not have a downstream port. See the special instructions in [6.2.3.3](#).

5.3.6 The distance between the tank (item 4) and the upstream pressure-measuring tube (item 6) for the discharge test, or between the tank (item 4) and downstream pressure-measuring tube (item 10) for charge test, shall be as short as possible. The volumes of all components and conductors in [Figures 1](#) and

2 between items 3 and 13 (if item 13 is used) or between items 3 and 8 (if item 13 is not used) shall be added to the volume of the tank.

5.3.7 The pressure-measuring tubes (items 6 and 10) and the transition connectors (items 7 and 9) shall be in accordance with ISO 6358-1. It is not necessary to have a temperature-measuring connection in the pressure-measuring tubes because the temperature is measured in the tank.

5.3.8 For any locations where liquid can collect, installation of a drain separator is recommended.

5.3.9 The shifting time of the flow control solenoid valve (item 13) shall be sufficiently short to limit the transient time at the beginning of test data collection.

5.3.10 When connecting pressure measuring instruments, the dead volume shall be limited as much as possible to avoid long response time, delays, and phase lag for measurements.

5.4 Requirements for the tank (item 4)

5.4.1 Structure

The tank shall be suitably structured as shown in [Figure 3](#) and consist of the components listed in [Table 5](#). Dimensions of the flow port shall conform to the dimensions given in [Table 6](#).

The tank shall conform to any local, national, and/or regional regulations and standards related to pneumatic containers.

The ratio of the height of the tank to its diameter should not exceed 2:1.

The junction of the flow port with the internal surface of the tank shall be convergent shaped so as to avoid pressure loss. The dimensions and arrangement of connection ports other than the flow port are determined by the test operator.

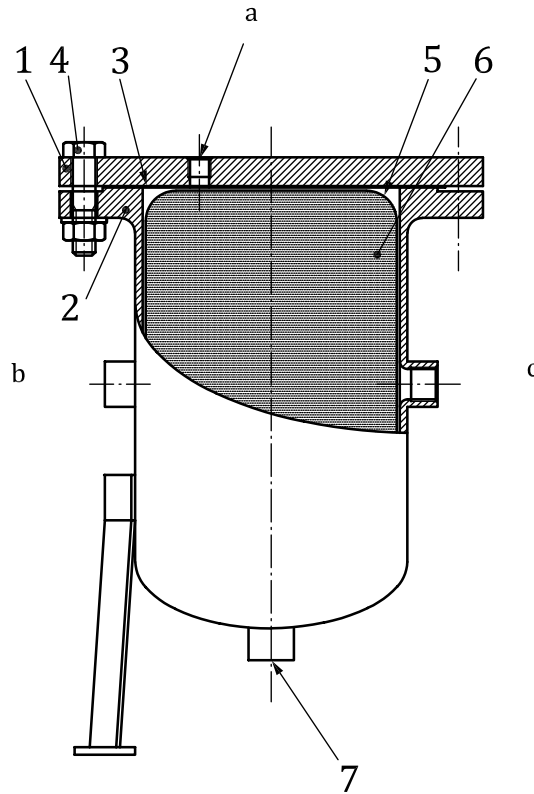

Key

- a Measuring ports (temperature and pressure)
- b Source port
- c Flow port

Figure 3 — Structure of the tank

Table 5 — Key to tank components

Key item number	Description	Comments
1	Lid	
2	Tank body	
3	Gasket	
4	Flange fastener (nut and bolt)	Six or more pieces, equally arranged
5	Metal net	See 5.4.2.
6	Stuffed material	See 5.4.2.
7	Drain valve	

Table 6 — Thread size of flow port

Tank volume, V , in m^3	Thread size
$V \leq 0,0025$	G 1/8
$0,0025 < V \leq 0,0063$	G 1/4
$0,0063 < V \leq 0,014$	G 3/8
$0,014 < V \leq 0,032$	G 1/2
$0,032 < V \leq 0,066$	G 3/4
$0,066 < V \leq 0,100$	G 1
$0,100 < V \leq 0,190$	G 1 1/4
$0,190 < V \leq 0,310$	G 1 1/2
$0,310 < V \leq 0,510$	G 2
$0,510 < V \leq 0,730$	G 2 1/2
$0,730 < V \leq 1,100$	G 3

5.4.2 Stuffed material

The stuffed material, which is used to reduce the change in air temperature, shall be resistant to corrosion and pressure and shall be distributed evenly in the tank. If copper wires are used as the stuffed material, wires of equivalent diameter 3×10^{-5} m to 5×10^{-5} m shall be stuffed in the tank at a density of 3×10^{-4} kg/m³.

NOTE The equivalent diameter means the diameter of the cross-sectional area of a noncircular shape assumed as equivalent to the diameter of the cross-sectional area of a circular shape.

The stuffed material shall be wrapped with a metallic net to prevent it from flowing out of the flow port. It is desirable that a suitable frame supports the stuffed material to prevent it from leaning inside the tank. Further information is given in [Annex C](#).

5.4.3 Volume

The volume of the tank, V , in m^3 should be calculated using Formula (1):

$$V \geq 5 \times 10^5 C \quad (1)$$

where

C is the estimated sonic conductance of the component under test, in $\text{m}^3/(\text{s} \cdot \text{Pa})(\text{ANR})$.

NOTE 1 The tank volume is the net value obtained by subtracting the volume of the stuffed material from the volume of the empty air tank.

NOTE 2 The test method to determine the tank volume is given in [Annex B](#).

5.5 Special requirements

5.5.1 The special requirements given in 5.6 of ISO 6358-1 apply for this part of ISO 6358.

5.5.2 The digital recorder shall be set to sample pressure at a time interval determined in accordance with Formulae (2) or (3). Approximately 1000 pressure data points will be obtained during discharge or charge tests. These criteria have an effect on the calculations performed in [6.3](#).

— For discharge tests:

$$\Delta t \approx 2,5 \times 10^{-8} \frac{V}{C} \quad (2)$$

— For charge tests:

$$\Delta t \approx 1,5 \times 10^{-8} \frac{V}{C} \quad (3)$$

where

Δt is the time interval for sampling pressure, in s;

C is the estimated sonic conductance of the component under test, in $\text{m}^3/(\text{s} \cdot \text{Pa})(\text{ANR})$;

V is the tank volume, in m^3 .

6 Test procedures

6.1 Test conditions

6.1.1 Test fluid

6.1.1.1 Air should be used as the test fluid. If a different fluid is used, it shall be stated in the test report.

6.1.1.2 The gas shall be filtered and conditioned to comply with the recommendations of the manufacturer of the component under test.

6.1.2 Checks

Periodically check that the pressure-tapping holes are not blocked by liquids or solid particles.

6.1.3 Test measurements

6.1.3.1 Each set of test readings shall be recorded after steady-state conditions of temperature and pressure in the tank have been reached. The variations of pressures and temperature indications shall not exceed the limits given in the column "Allowed test conditions variation" of [Table 7](#).

6.1.3.2 Pressure and temperature shall be measured within the measurement accuracy specified in [Table 7](#).

Table 7 — Measurement accuracy and allowed test condition of parameters

Parameter	Measurement accuracy	Allowed test condition variation
Volume	$\pm 1 \%$	-
Time	$\pm 1 \%$	-
Upstream pressure	$\pm 0,5 \%$	$\pm 1 \%$
Downstream pressure	$\pm 0,5 \%$	$\pm 1 \%$
Tank pressure	$\pm 0,5 \%$	$\pm 1 \%$
Temperature	$\pm 1 \text{ K}$	$\pm 3 \text{ K}$

6.1.3.3 Flow-rate conditions in each flow path shall be maintained constant within the component while taking measurements to ensure there is no inadvertent movement of component parts.

6.2 Measuring procedures

6.2.1 Requirements for testing to publish catalogue ratings

If data are to be used for publishing ratings in a catalogue, a sample consisting of a minimum of five test units selected from a random production lot shall be tested in accordance with the following procedures.

6.2.2 Selection of measuring procedure

Either the procedure described in [6.2.3](#) or the procedure described in [6.2.4](#) shall be selected in accordance with the scope of this part of ISO 6358.

6.2.3 Measuring procedures for discharge test

6.2.3.1 Set the pressure of the pressure regulator (item 2) at 700 kPa (7 bar), and open the shut-off valve (item 3) to charge air into the tank (item 4). Leave the tank in this state until temperature and pressure in the tank reach steady-state conditions.

6.2.3.2 Close the shut-off valve (item 3) and measure the initial pressure, p_3 , using pressure transducer 16, initial temperature, T_3 , using the temperature-measuring instrument (item 5) in the tank, and atmospheric pressure using the barometer (item 14).

6.2.3.3 Open the component under test (item 8) or the solenoid valve (item 13) to discharge air from the tank (item 4) into the atmosphere. Measure pressure in the tank, p_3 , upstream pressure, p_1 , and downstream pressure, p_2 , during discharge using the pressure transducers (items 16, 11, and 12), and record the values using the digital recorder (item 15) as shown in [Figure 4](#). If the downstream transition connector cannot connect to a component under test, measure atmospheric pressure as downstream pressure, p_2 .

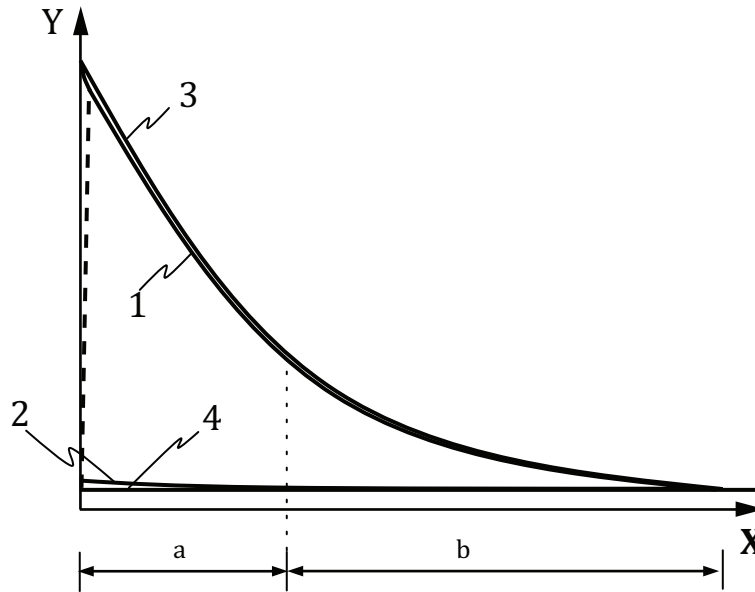

Key

- X time
- Y pressure
- 1 upstream pressure
- 2 downstream pressure
- 3 pressure in the tank
- 4 atmospheric pressure
- a choked flow region
- b subsonic flow region

NOTE The broken line indicates the upstream pressure, p_1 , when solenoid valve 13 is used to start the test. But the upstream pressure, p_1 , begins at the maximum value if the component under test can perform the shift to start the test.

Figure 4 — Pressure response in the tank during discharge

6.2.4 Measuring procedures for charge test (see Figure 2)

6.2.4.1 Reduce the pressure in the tank (item 4) to approximately 2 kPa absolute (0,02 bar absolute) using the vacuum pump (item 18). Then, close the shut-off valve (item 3) and leave the tank in this state until the pressure in the tank reaches steady-state conditions. Measure the initial pressure, p_3 , using the pressure transducer (item 16), initial temperature, T_3 , using the temperature-measuring instrument (item 5) in the tank, and the atmospheric pressure using the barometer (item 14).

6.2.4.2 Open the component under test (item 8) or the solenoid valve (item 13) to charge the air from the atmosphere into the tank. Measure pressure in the tank, p_3 , upstream pressure, p_1 , and downstream pressure, p_2 , during charge using the pressure transducers (items 16, 11, and 12), and record the values using the digital recorder (item 15) as shown in [Figure 5](#).

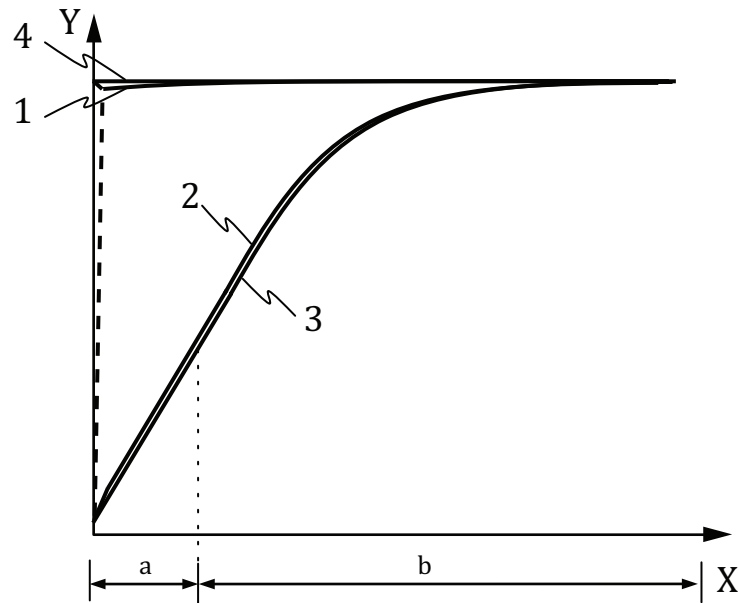

Key

- X time
- Y pressure
- 1 upstream pressure
- 2 downstream pressure
- 3 pressure in the tank
- 4 atmospheric pressure
- a choked flow region
- b subsonic flow region

NOTE The broken line indicates the upstream pressure, p_1 , when a solenoid valve 13 is used to start the test. But the upstream pressure, p_1 , begins at the maximum value if the component under test can perform the shift to start the test.

Figure 5 — Pressure response in the tank during charge

6.3 Calculation of characteristics

6.3.1 Sonic conductance, C

6.3.1.1 Smoothing of pressure in the tank, p_3

Perform a calculation to smooth the raw pressure data in the tank from a 21-point moving average by using Formula (4).

$$p'_{3(j)} = \frac{1}{21} \sum_{i=j-10}^{i=j+10} p_{3(i)} \quad (4)$$

where

$p_{3(i)}$ is the pressure in the tank, in Pa ($i = 1, 2, \dots, n$);

$p'_{3(j)}$ is the pressure in the tank after moving average processing, in Pa ($j = 11, 12, \dots, n-10$);

n is the number of pressure data points measured during the discharge test or the charge test.

6.3.1.2 Conductance characteristics curve

Calculate the conductance, C_e , for each value of j over the measured region shown in [Figure 4](#) for the discharge test, or [Figure 5](#) for the charge test, by using Formulae (5) or (6). Describe the conductance versus the pressure ratio on the graph as shown in [Figures 7](#) or [8](#):

— for discharge test

$$C_{e(j)} = \frac{V(p'_{3(j-10)} - p'_{3(j+10)})}{20p_{1(j)}R\rho_0\Delta t\sqrt{T_0T_3}} \quad (5)$$

— for charge test

$$C_{e(j)} = \frac{V(p'_{3(j+10)} - p'_{3(j-10)})}{20p_{1(j)}R\rho_0\Delta t\sqrt{T_0T_3}} \quad (6)$$

where

$C_{e(j)}$ is the conductance of a component under test, in $\text{m}^3/(\text{s}\cdot\text{Pa})(\text{ANR})$ ($j = 21, 22, \dots, n - 20$); see [Figure 6](#) for a description of how these data are organized;

$p_{1(j)}$ is the upstream pressure, in Pa;

$p'_{3(j-10)}$ is the pressure in the tank after smoothing before 10 points, in Pa;

$p'_{3(j+10)}$ is the pressure in the tank after smoothing after 10 points, in Pa;

V is the volume of the tank, in m^3 ;

R is the gas constant, in $\text{J}/(\text{kg}\cdot\text{K})$; [for air, $R = 287 \text{ J}/(\text{kg}\cdot\text{K})$];

ρ_0 is the mass density of air at the standard reference atmosphere, in kg/m^3 ;

T_0 is the absolute temperature at standard reference atmosphere, in K;

T_3 is the absolute temperature in the tank at start of discharge, in K;

Δt is the time interval for sampling pressure determined in [5.5.2](#), in s.

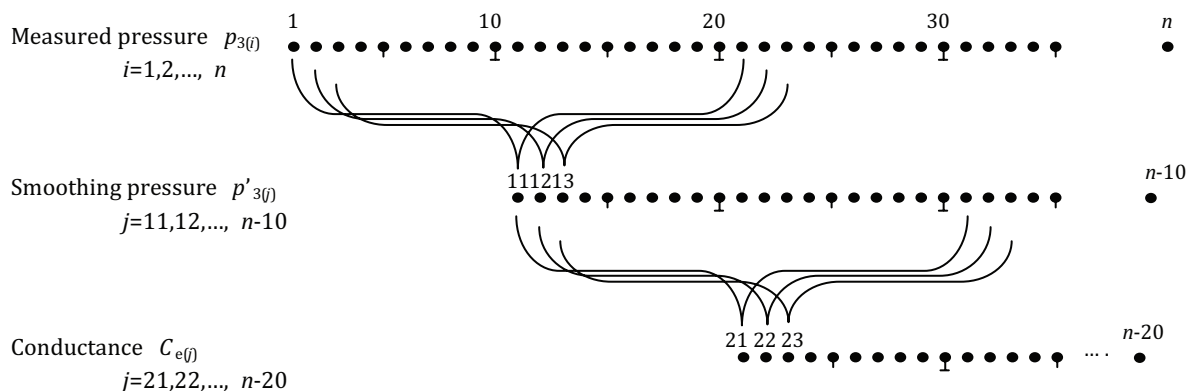
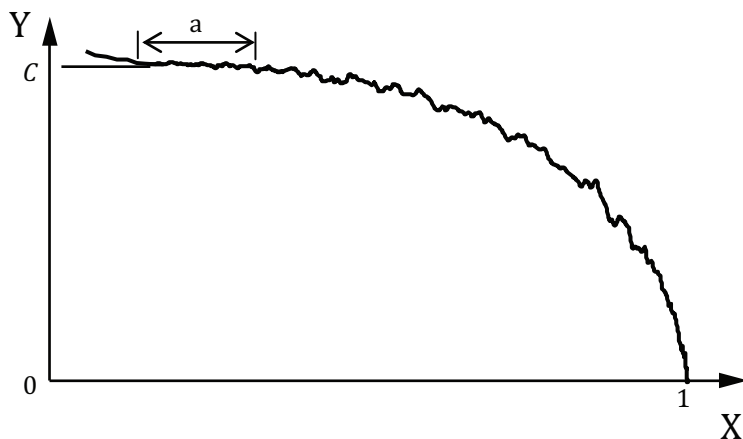

Figure 6 — Value of j in $C_{e(i)}$

6.3.1.3 Calculation of sonic conductance, C

Calculate the sonic conductance, C , by averaging the saturated region of the conductance, C_e , as shown in [Figures 7](#) or [8](#). The saturated region is characterized by several values of the conductance that are at maximum values compared to all others. However, this does not include the transient values obtained immediately after starting a charge or discharge.

If the C_e coefficients vary significantly in the choked flow region, the component could be considered to exhibit pressure dependence. In this case, first repeat the procedure in [6.2.3.1](#) through [6.2.3.3](#) at the upper limit of the pressure range of the component, then determine the K_p and C coefficients in accordance with [6.3.3](#).



Key

- X back-pressure ratio p_2/p_1
- Y conductance C_e
- a saturated region

Figure 7 — Conductance characteristics for discharge test

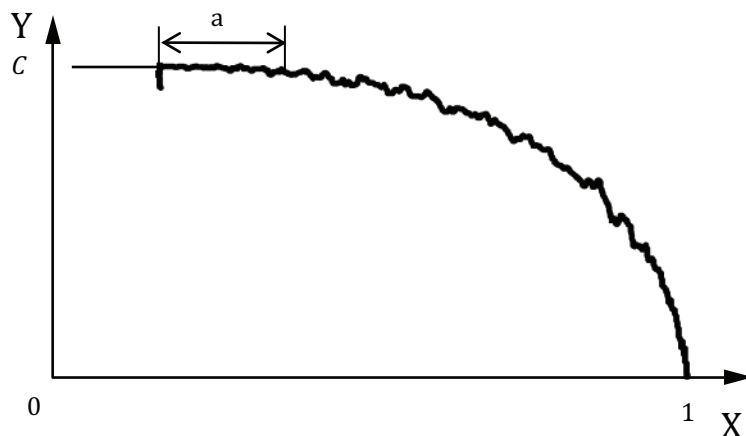

Key

- X back-pressure ratio p_2/p_1
- Y conductance C_e
- a saturated region

Figure 8 — Conductance characteristics for charge test

6.3.2 Critical back-pressure ratio, b , and subsonic index, m

6.3.2.1 Calculate the critical back-pressure ratio, b , and subsonic index, m , from Formula (7) by the least-square method using all of pressure ratios, p_2/p_1 , and conductance ratios, C_e/C , in the subsonic flow region determined in 6.3.1. See Annex F for the calculation, giving attention to the second paragraph in F.2.2.1.

$$\frac{C_e}{C} = \left\{ 1 - \left(\frac{p_2 - b}{p_1 - b} \right)^2 \right\}^m \quad (7)$$

6.3.2.2 If the value of the subsonic index, m , calculated in [6.3.2.1](#) is between 0,48 and 0,52, its value may be corrected to 0,5 to reduce the number of characteristic parameters. In this case, recalculate the corresponding critical back-pressure ratio, b , in accordance with [6.3.2.1](#), with $m = 0,5$.

6.3.3 Pressure dependence coefficient, K_p

Taking C_{\max} as the value of conductance for the maximum upstream pressure, plot the pressure dependence as shown in [Figure 9](#) using the test result stated in [6.2.3](#), then find the correlative line in the range of the conductance ratio close to 1. The plot on this line can be considered to define the choked flow region. The slope of this line is the value of the pressure dependence coefficient, K_p . When selecting a conductance ratio and upstream pressure at two positions on this line, K_p can be calculated by using Formula (8).

$$K_p = \frac{1 - \frac{C_{\text{low}}}{C_{\text{max}}}}{p_{1\text{max}} - p_{1\text{low}}} \quad (8)$$

where

$p_{1\text{low}}$ is the lower upstream pressure of the linear dependence.

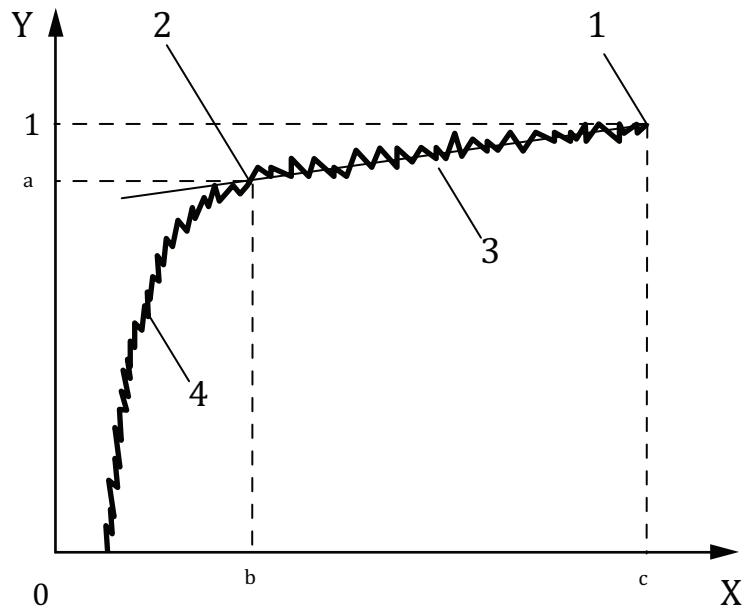

Key

- X upstream pressure p_1
- Y conductance ratio C_e/C_{max}
- 1 first data point, taken at maximum upstream pressure
- 2 second point on the line
- 3 correlative line
- 4 test results
- a conductance ratio C_{low}/C_{max}
- b upstream pressure p_{1low}
- c upstream pressure p_{1max}

Figure 9 — Plot of conductance ratio versus upstream pressure

7 Presentation of test results

7.1 All measurements and the results of calculations shall be tabulated by the testing laboratory.

7.2 If data are to be used for publishing ratings in a catalogue, the average of results from the test units for each characteristic listed in 7.3 shall be reported.

7.3 The following performance characteristics related to flow-rate capacity, which are calculated in accordance with 6.3, shall be stated:

- a) sonic conductance, C , [also see item d) below],
- b) critical back-pressure ratio, b ,
- c) subsonic index, m , and
- d) if necessary, pressure dependence coefficient, K_p , upstream pressure, p_{1max} , and sonic conductance, C_{max} at the upstream pressure value p_{1max} .

- e) From these characteristics the performance of the component can be predicted using Formulae (E.1) and (E.2) of Annex E of ISO 6358-1 and compared.

7.4 The record of the calibration of measuring devices shall be available.

8 Identification statement (reference to this part of ISO 6358)

Use the following statement in test reports, catalogues, and sales literature when electing to comply with this International Standard:

“Flow-rate characteristics of pneumatic components determined in accordance with the discharge test or charge test of ISO 6358-2, *Pneumatic fluid power — Determination of flow-rate characteristics of components — Part 2: Alternative test methods*”

Annex A (informative)

Evaluation of measurement uncertainty

A.1 General

The ISO guide of the uncertainty in measurement (GUM:2000) provides the current international consensus method for estimating the measurement uncertainty. There are different possibilities to estimate measurement uncertainty, the strict mathematical way is described most extensively in the GUM, but the other pragmatic methods that are in conformity with GUM can be used. The most important rule is: effort and expenditure for determination of uncertainties should be clearly guided by the principle "fit for purpose", that is, it should be good enough to meet the requirements of the user of the measurement data, but it should not be overdone in light of the application. This annex uses this principle.

GUM groups uncertainty components into type A and type B according to the way data were obtained. Type A components are calculated by statistical means from repeated measurements, while type B components are taken from other sources, e.g. reference material, calibration certificates, accepted values of constants, resolution, instability, environmental conditions.

In practice, however, a combined approach will be the most suitable; this combined approach will apply very often, as it is impossible to estimate each uncertainty individually. In this case, type B will be used with reference materials and quality control materials to avoid some systematic measuring error. The single uncertainties are combined applying the law of propagation of uncertainty. The type A uncertainty estimate is an estimate derived from the statistical analysis of experimental data. This type of uncertainty evaluation is preferred when the value of a measurand will be the average of several test results or is in relation with non-independent variables.

A.2 Evaluation of measurement uncertainty of the sonic conductance, C , using type B

A.2.1 Measurand conductance, C_e

According to this part of ISO 6358, the most important flow-rate characteristic parameter of a pneumatic component is the sonic conductance, C . The equation relating measurand conductance, C_e , and evolution of the conductance during the charge or discharge test can be expressed using either Formulae (E.3) or (E.8); following these equations, the quantity subject to measurement, and input quantities are:

$$C_e = (\text{sign}) \frac{1}{\rho_0 p_1} \sqrt{\frac{T_3}{T_0}} \frac{V}{RT_3} \frac{dp_3}{dt} = f(p_1, T_3, V, \frac{dp_3}{dt}) \quad (\text{A.1})$$

A.2.2 Identification of uncertainty of input quantities

According to Formula (A.1), the input quantities subject to measurement are:

- a) p_1 – upstream stagnation pressure

Uncertainty follows the accuracy of measuring instrument: $\pm \Delta p_1 = \pm 0,5 \%$

Method of measurement of stagnation pressure (wall tapping): $\Delta p_1 = +0,3 \%$

- b) T_3 – upstream stagnation temperature

Uncertainty follows the accuracy of measuring instrument: $\pm \Delta T_3 = \pm 1 \text{ K}$

It must be noted here that all measurement instabilities are included in the previous limits of uncertainty. If it is not, the reality in this range of instability must be added at the previous ΔT . However, the temperature variation (decreasing in the discharge case or increasing in charge case) must be less than 3K from the isothermal tank. That is the condition for the validity of the isothermal assumption of air inside the tank and the flow rate can be calculated by only recording the pressure response.

c) V – volume of isothermal tank

Uncertainties will follow the evaluation of Formula (B.14)

d) dp_3/dt – change in pressure in the tank

Uncertainty will follow the accuracy of measuring instrument and the time base (sampling period).

A.2.3 Sensitivity coefficient

Sensitivity coefficients are obtained from partial derivatives of the model function f with respect to the input quantities. For the evolution of conductance, C_e :

$$\frac{\partial f}{\partial p_1} = \frac{1}{\rho_0 p_1^2} \sqrt{\frac{T_3}{T_0}} \frac{V}{RT_3} \frac{dp_3}{dt} \quad \text{for the input } p_1 \quad (\text{A.2})$$

$$\frac{\partial f}{\partial T_3} = \frac{1}{2\rho_0 p_1} \sqrt{\frac{T_3}{T_0}} \frac{V}{RT_3 T_0} \frac{dp_3}{dt} \quad \text{for the input } T_3 \quad (\text{A.3})$$

$$\frac{\partial f}{\partial \left(\frac{dp_3}{dt} \right)} = \frac{1}{\rho_0 p_1} \sqrt{\frac{T_3}{T_0}} \frac{V}{RT_3} \quad \text{for the input } \frac{dp_3}{dt} \quad (\text{A.4})$$

A.2.4 Expression of absolute standard uncertainty

The absolute standard uncertainty for the measured conductance, C_e , is given by:

$$\Delta C_e = \left| \Delta p_1 \frac{\partial f}{\partial p_1} \right| + \left| \Delta T_3 \frac{\partial f}{\partial T_3} \right| + \left| \Delta \left(\frac{dp_3}{dt} \right) \frac{\partial f}{\partial \left(\frac{dp_3}{dt} \right)} \right| \quad (\text{A.5})$$

If the relative or percentage standard uncertainty is desired, it is given by:

$$\Delta C_e \% = 100 \frac{\Delta C_e}{C_e} \quad (\text{A.6})$$

A.3 Evaluation of measurement uncertainty of the sonic conductance, C , using Type A

A.3.1 Measurand sonic conductance, C

According to this part of ISO 6358, the most important flow-rate characteristic parameter of a pneumatic component is the sonic conductance, C . The evolution of conductance, C_e , is defined by Formula (A.1) can be plotted over the ratio of downstream pressure to upstream pressure, p_2/p_1 . These curves show correlatively the pressure variation and the conductance characteristics variation. See 6.3.1.3 of this part of ISO 6358.

A.3.2 Expression of standard uncertainty

If the measurement points in the choked flow region are considered, an estimate of the measurand is obtained that will be the average of several data points, as follows:

$$C = \frac{1}{n} \sum_{i=1}^n C_i \quad (\text{A.7})$$

where

n is number of measurement points in the choked flow region ($n > 1$);

C_i is the result of data measurement at i .

The experimental standard deviation, s_c , characterizes the variability of observed values, C_i , in the choked flow region, as follows:

$$s_c = \sqrt{\frac{\sum_{i=1}^{i=n} (C_i - C)^2}{n-1}} \quad (\text{A.8})$$

This experimental standard deviation of the sonic conductance measurement can be taken as an estimate of uncertainty (type A).

A.4 Evaluation of measurement uncertainty of the critical back-pressure ratio, b , and subsonic index, m , using type B

A.4.1 Measurands

According to this part of ISO 6358, the second most important flow-rate characteristic parameter of a pneumatic component is the critical back-pressure ratio, b . The subsonic index, m , is eventually used to represent the subsonic flow behaviour. The equation relating measurands b and m , i.e. the quantity subject to measurement, and input quantities is:

$$\frac{C_e}{C} = \left\{ 1 - \left(\frac{\frac{p_2}{p_1} - b}{1 - b} \right)^2 \right\}^m \quad (\text{A.9})$$

This equation is solved by the non linear least square method (NLLSQ) with the variables as follows:

$$y_i = \frac{C_e}{C} \quad (\text{A.10})$$

$$x_i = \frac{p_{2,i}}{p_{1,i}} \quad (\text{A.11})$$

The difference between an observed value and the value given by the model is:

$$\delta_i = y_i - \left\{ 1 - \left(\frac{x_i - b}{1 - b} \right)^2 \right\}^m \quad (\text{A.12})$$

The sum of squared difference will be the least values (see Annex G). The NLLSQ are conceptually inadequate to generate a statistical estimator of uncertainty. A pragmatic way to estimate the variability of b and m can be to use the NLLSQ with the minimum and maximum values of C found in A.3.2.

A.4.2 Identification and expression of uncertainty

As mentioned in A.4.1, the functional relationship between the measurands b and m and the influence quantities is an arduous task. In this paragraph, two calculations will focus on the upper and lower limits of these characteristics. The uncertainty of these flow-rate characteristics will be defined here as limits associated with the NLLSQ calculation results from maximum and minimum sonic conductance determined in the choked flow region. In these conditions:

$$\{C - s_c\} \rightarrow NLLSQ \rightarrow [b, m]_{C_{\min}} \quad (\text{A.13})$$

$$\{C - s_c\} \rightarrow NLLSQ \rightarrow [b, m]_{C_{\max}} \quad (\text{A.14})$$

From these calculation results, the maximum absolute differences between these limits and the best values attributable to these measurands are the two values: $|\Delta b|_{\max}$ and $|\Delta m|_{\max}$. These values are now considered as the uncertainty of the result of a measurement, which is expressed as:

$$b \pm |\Delta b|_{\max} \quad \text{for the critical back-pressure ratio} \quad (\text{A.15})$$

$$m \pm |\Delta m|_{\max} \quad \text{for the subsonic index} \quad (\text{A.16})$$

NOTE These calculations show that:

- a) concerning the choked flow region of the conductance curve, the comparison of results can be done directly by comparing the values of sonic conductance, C ; but
- b) concerning the subsonic flow region of the conductance curve, the comparison of each parameter b and m independently is not sufficient to compare the results. It is necessary to add a graphical comparison of conductance curves, because the variations of each parameter C , b , and m can compensate to give an equivalent subsonic flow region of the conductance curve.

A.5 Repeatability and reproducibility

A simple method for basing uncertainty estimates on repeatability and reproducibility can be made by statistical means from repeated measurements. This method has a great advantage in that most testing laboratories are already acquainted with repeatability and reproducibility experiments, but this method assumes that all significant systematic effects have been identified and either eliminated or compensated for by the application of suitable corrections.

For complete details, see ISO 5725 (in particular ISO 5725-2) and ISO 21748.

A.6 Practical uncertainty due to tank volume

In the discharge test and charge test, flow rate is calculated by a tank volume, V , and the change in pressure in the tank from dp_3/dt in Formula (A.1). Uncertainty of C from the discharge and charge tests when the tank volume varies is shown in Figure A.1. The abscissa is V/C , which is tank volume, V , divided by sonic conductance, C . This value represents an indicator of discharge or charge time. The value of C is more variable when the tank volume is too small for both the discharge test and charge test. When $V/C > 5 \times 10^5$, as described in 5.4.3, variations in C , b , and m due to tank volume are minimised.

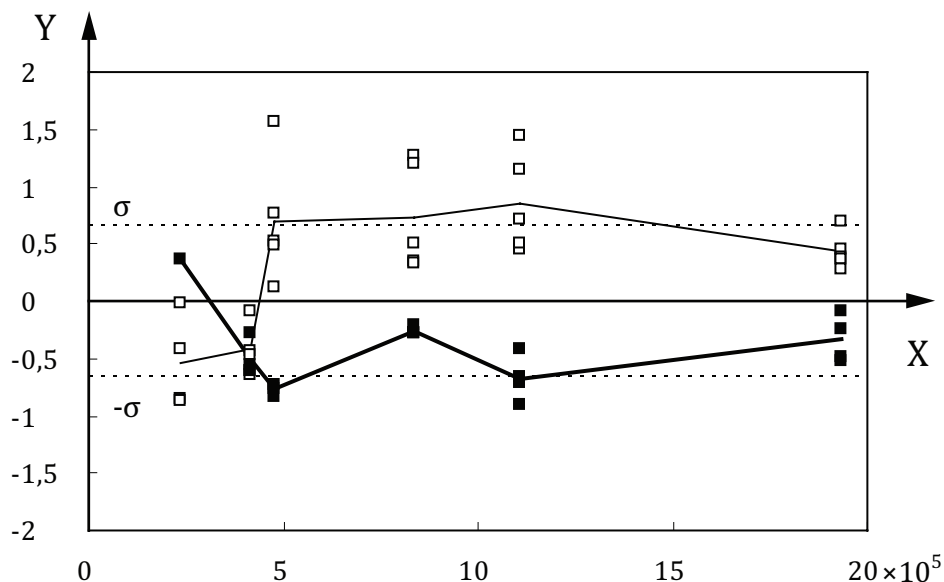

Key	
X	V/C [$m^3/(s.Pa)(ANR)$]
Y	C [%]
□	discharge test
—	mean
■	charge test
—	mean

Figure A.1 — Distributions of tank volume and practical uncertainty

A.7 Practical uncertainty due to temperature

In the discharge test, the calculation of sonic conductance, C , is based on the temperature of air in the tank at the start of discharge, even though the temperature in the isothermal tank will slightly decrease during discharge. Similarly, in the charge test, the temperature in the isothermal tank will slightly increase. The error of this decrease or increase of temperature is shown in Formula (A.17). In the discharge test, C is calculated to be smaller than a true value by 0,5 % when temperature decreases by 3 K at a C calculation point. In the charge test, C is calculated to be larger than a true value by 0,17 % when the temperature rises by 1 K.

$$\frac{1}{2} \Delta T_3 (\text{ISO}) = \frac{T_3' - T_3}{2T_3} \% \quad (\text{A.17})$$

A.8 Error due to transient change of temperature

Formula (A.1) of the discharge test ignores the temperature change of the isothermal tank as described in [Annex E](#). When considering the transient change of temperature, the second term appears as shown in Formula (A.18), where M denotes the mass of air. In an actual test, the temperature will decrease by a few K even when an isothermal tank is used, and so dT/dt will become the maximum value when the discharge starts. Therefore, in accordance with this part of ISO 6358, C is calculated to be larger by approximately 1 % at initial discharge.

However, if this transient interval is eliminated in the calculation of C as described in [6.3.1.3](#), its influence on the calculated C becomes small. Also, in the charge test, C is calculated to be slightly smaller due to temperature increase at initial charge, but this result will have little effect on the calculation.

$$C = \frac{V}{\rho_0 p_1 R \sqrt{T_0 T_3}} \frac{dp_3}{dt} - \frac{M}{\rho_0 p_1 \sqrt{T_0 T_3}} \frac{dT}{dt} \quad (\text{A.18})$$

Annex B (normative)

Test method to determine and calibrate the volume of an isothermal tank

B.1 Test circuit

The test circuit shown in [Figure B.1](#) shall be used.

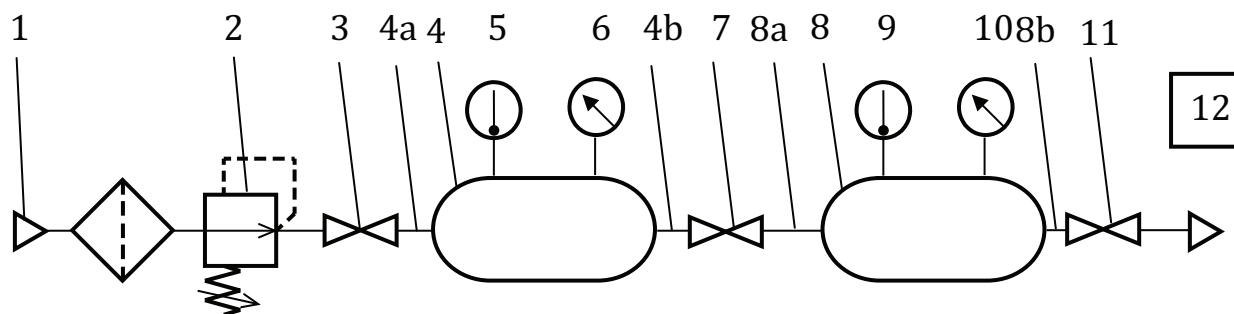

Key

- 1 compressed gas source and filter
- 2 adjustable pressure regulator
- 3, 7, and 11 shut-off valve
- 5 and 9 temperature measuring instrument
- 6 and 10 pressure transducer
- 4 isothermal tank under test
- 4a and 4b piping
- 8 reference tank (of a known volume)
- 8a and 8b piping
- 12 barometer

Figure B.1 — Test circuit

B.2 General requirements

B.2.1 Volume V_i of the isothermal tank includes the volume of piping 4a and 4b. Volume V_s of the reference tank includes the volume of piping 8a and 8b. These piping volumes shall be determined separately, so that these data can be used with other tanks.

B.2.2 The volumes V_i and V_s of, respectively, the isothermal tank under test (item 4) and the reference tank (item 8) shall be selected using Formula (B.1).

$$0,1 \leq \frac{V_i}{V_s} \leq 10 \tag{B.1}$$

B.2.3 The location of the isothermal tank under test (item 4), the reference tank (item 8), the temperature measuring instruments (items 5 and 9), and the pressure gauges (items 6 and 10) in [Figure B.1](#) may

be changed. In that case, the references to the isothermal tank under test (item 4) and the reference tank (item 8) in B.3.1 and B.3.3 shall be replaced with references to the reference tank (item 8) and the isothermal tank under test (item 4).

B.2.4 Before conducting measurements, ensure that none of the components in [Figure B.1](#), from item 3 to item 11, leak.

B.3 Measurement procedures

B.3.1 Close the first two shut-off valves in the circuit (items 3 and 7), and open the third shut-off valve (item 11). Set the pressure of the pressure regulator (item 2) at 700 kPa (7 bar), and open the first shut-off valve (item 3) to charge the air into the isothermal tank under test (item 4). After charging, allow sufficient time for the temperature and pressure in the tank to reach steady-state conditions.

B.3.2 Close the first and last shut-off valves (items 3 and 11). Measure the atmospheric pressure, p_a , using the barometer (item 12), and measure the initial pressure, p_{s1} , using the pressure gauge (item 10) and initial temperature, T_{s1} , using the temperature measuring instrument (item 9) in the reference tank (item 8). Measure the initial pressure, p_{i1} , using the pressure gauge (item 6) and initial temperature, T_{i1} , using the temperature measuring instrument (item 5) in the isothermal tank under test (item 4).

B.3.3 Open the second shut-off valve (item 7) to discharge air from the isothermal tank under test (item 4) into the reference tank (item 8). After charging, allow sufficient time for the temperature and pressure in the tanks to reach steady-state conditions.

B.3.4 Measure the pressures, p_{i2} and p_{s2} , using the pressure gauges (items 6 and 10), respectively, and the temperature, T_{i2} and T_{s2} , using the temperature measuring instruments (items 5 and 9), respectively, in the isothermal tank under test (item 4) and the reference tank (item 8).

B.3.5 Open the third shut-off valve (item 11) to discharge the air from the isothermal tank under test (item 4) and the reference tank (item 8) to the atmosphere.

B.4 Calculation of tank volume

Use Formula (B.2), which is based on the equation of state, to calculate the volume of the isothermal tank under test (item 4), V_i .

$$V_i = V_s \left(\frac{\frac{p_{s2} - p_{s1}}{T_{s2} - T_{s1}}}{\frac{p_{i1} - p_{i2}}{T_{i1} - T_{i2}}} \right) \quad (\text{B.2})$$

where

p_{i1} is the initial pressure in the isothermal tank under test (item 4), in kPa;

p_{i2} is the pressure in the isothermal tank under test (item 4) when the second shut-off valve (item 7) is opened and the temperature and pressure in the tanks reach steady-state conditions, in kPa;

p_{s1} is the initial pressure in the reference tank (item 8), in kPa;

p_{s2} is the pressure in the reference tank (item 8) when the second shut-off valve (item 7) is opened and the temperature and pressure in the tanks reach steady-state conditions, in kPa;

T_{i1} is the initial temperature in the isothermal tank under test (item 4), in K;

T_{i2} is the temperature in the isothermal tank under test (item 4) when the second shut-off valve (item 7) is opened and the temperature and pressure in the tanks reach steady-state conditions, in K;

T_{s1} is the initial temperature in the reference tank (item 8), in K;

T_{s2} is the temperature in the reference tank (item 8) when the second shut-off valve (item 7) is opened and the temperature and pressure in the tanks reach steady-state conditions, in K;

V_s is the known volume of tank 8, in dm³.

B.5 Evaluation of measurement uncertainty of the volume of isothermal tank (Type B of the GUM)

B.5.1 Measurand volume V_i

Formula (B.3) relates the measurand V_i , i.e. the quantity subject to measurement, and input quantities:

$$V_i = V_s \left(\frac{p_{s2}}{T_{s2}} - \frac{p_{s1}}{T_{s1}} \right) \left(\frac{p_{i1}}{T_{i1}} - \frac{p_{i2}}{T_{i2}} \right)^{-1} \quad (\text{B.3})$$

$$V_i = f(V_s, p_{s1}, p_{s2}, T_{s1}, T_{s2}, p_{i1}, p_{i2}, T_{i1}, T_{i2}) \quad (\text{B.4})$$

B.5.2 Identification of uncertainty of input quantities

According to Formulae (B.3) and (B.4), the input quantities subject to measurement are:

- a) V_s volume of reference tank
 - Uncertainty following accuracy of measuring instrument: $\pm\Delta V_s = \{ \pm 1 \%$
- b) p_s and p_i stagnation pressures of reference and isothermal tanks
 - Uncertainty following accuracy of measuring instrument: $\pm\Delta p_s = \{ \pm 0,5 \%$
 - Uncertainty following accuracy of measuring instrument: $\pm\Delta p_i = \{ \pm 0,5 \%$
- c) T_s and T_i stagnation temperature of gas in reference and isothermal tanks
 - Uncertainty following accuracy of measuring instrument: $\pm\Delta T_s = \{ \pm 1\text{K} \}$
 - Uncertainty following accuracy of measuring instrument: $\pm\Delta T_i = \{ \pm 1\text{K} \}$

All measurement instabilities are included in the previous limits of uncertainty. If it does not reflect reality, this range of instability shall be added to the previous ΔT .

These input quantities are independent variables, and the sensitivity can be calculated.

B.5.3 Sensitivity coefficient

Sensitivity coefficients are obtained from partial derivatives of the model function f with respect to the input quantities. For the volume of the isothermal tank under test (item 4), the following can be obtained by using Formulae (B.5) through (B.13), inclusive:

$$\frac{\partial f}{\partial V_s} = \left(\frac{p_{s2}}{T_{s2}} - \frac{p_{s1}}{T_{s1}} \right) \left(\frac{p_{i1}}{T_{i1}} - \frac{p_{i2}}{T_{i2}} \right)^{-1} \quad \text{for the input } V_s \quad (\text{B.5})$$

$$\frac{\partial f}{\partial p_{s1}} = -\frac{V_s}{T_{s1}} \left(\frac{p_{i1}}{T_{i1}} - \frac{p_{i2}}{T_{i2}} \right)^{-1} \quad \text{for the input } p_{s1} \quad (\text{B.6})$$

$$\frac{\partial f}{\partial p_{s2}} = \frac{V_s}{T_{s2}} \left(\frac{p_{i1}}{T_{i1}} - \frac{p_{i2}}{T_{i2}} \right)^{-1} \quad \text{for the input } p_{s2} \quad (\text{B.7})$$

$$\frac{\partial f}{\partial T_{s1}} = V_s \frac{p_{s1}}{T_{s1}^2} \left(\frac{p_{i1}}{T_{i1}} - \frac{p_{i2}}{T_{i2}} \right)^{-1} \quad \text{for the input } T_{s1} \quad (\text{B.8})$$

$$\frac{\partial f}{\partial T_{s2}} = -V_s \frac{p_{s2}}{T_{s2}^2} \left(\frac{p_{i1}}{T_{i1}} - \frac{p_{i2}}{T_{i2}} \right)^{-1} \quad \text{for the input } T_{s2} \quad (\text{B.9})$$

$$\frac{\partial f}{\partial p_{i1}} = -\frac{V_s}{T_{t1}} \left(\frac{p_{s2}}{T_{s2}} - \frac{p_{s1}}{T_{s1}} \right) \left(\frac{p_{i1}}{T_{i1}} - \frac{p_{i2}}{T_{i2}} \right)^{-2} \quad \text{for the input } p_{i1} \quad (\text{B.10})$$

$$\frac{\partial f}{\partial p_{i2}} = \frac{V_s}{T_{i2}} \left(\frac{p_{s2}}{T_{s2}} - \frac{p_{s1}}{T_{s1}} \right) \left(\frac{p_{i1}}{T_{i1}} - \frac{p_{i2}}{T_{i2}} \right)^{-2} \quad \text{for the input } p_{i2} \quad (\text{B.11})$$

$$\frac{\partial f}{\partial T_{i1}} = \frac{V_s p_{i1}}{T_{i1}^2} \left(\frac{p_{s2}}{T_{s2}} - \frac{p_{s1}}{T_{s1}} \right) \left(\frac{p_{i1}}{T_{i1}} - \frac{p_{i2}}{T_{i2}} \right)^{-2} \quad \text{for the input } T_{i1} \quad (\text{B.12})$$

$$\frac{\partial f}{\partial T_{i2}} = \frac{V_s p_{i2}}{T_{i2}^2} \left(\frac{p_{s2}}{T_{s2}} - \frac{p_{s1}}{T_{s1}} \right) \left(\frac{p_{i1}}{T_{i1}} - \frac{p_{i2}}{T_{i2}} \right)^{-2} \quad \text{for the input } T_{i2} \quad (\text{B.13})$$

B.5.4 Expression of absolute standard uncertainty

The absolute standard uncertainty for the measured volume of the isothermal tank under test (item 4) is given by Formula (B.14):

$$\Delta V_i = \left| \Delta V_s \frac{\partial f}{\partial V_s} \right| + \left| \Delta p_{s1} \frac{\partial f}{\partial p_{s1}} \right| + \left| \Delta p_{s2} \frac{\partial f}{\partial p_{s2}} \right| + \left| \Delta T_{s1} \frac{\partial f}{\partial T_{s1}} \right| + \left| \Delta T_{s2} \frac{\partial f}{\partial T_{s2}} \right| + \left| \Delta p_{i1} \frac{\partial f}{\partial p_{i1}} \right| + \left| \Delta p_{i2} \frac{\partial f}{\partial p_{i2}} \right| + \left| \Delta T_{i1} \frac{\partial f}{\partial T_{i1}} \right| + \left| \Delta T_{i2} \frac{\partial f}{\partial T_{i2}} \right| \quad (\text{B.14})$$

If the relative or percentage standard uncertainty is desired, it is given by Formula (B.15):

$$\Delta V_i \% = 100 \frac{\Delta V_i}{V_i} \quad (\text{B.15})$$

B.6 Example of test result

Figures B.2 and B.3 show the test result for the volume of an isothermal tank with a nominal volume of 20 dm³. Table B.1 shows an example of uncertainty calculation.

Figures B.2 and B.3 also show the test result of discharge from the isothermal tank under test to the reference tank and vice versa. The volume of reference tank was measured in advance. In Figure B.2, the pressure in the isothermal tank under test was set at about 790 kPa (7,9 bar), and in Figure B.3, the pressure in the reference tank was set at about 655 kPa (6,55 bar). Initial pressures, p_{i1} and p_{s1} , initial temperatures, T_{i1} and T_{s1} , and the atmospheric pressure were measured. Pressures, p_{i2} and p_{s2} , and temperatures, T_{i2} and T_{s2} , were measured 10 min after discharge. The volume of the isothermal tank under test was calculated using Formula (B.1) based on the measured value.

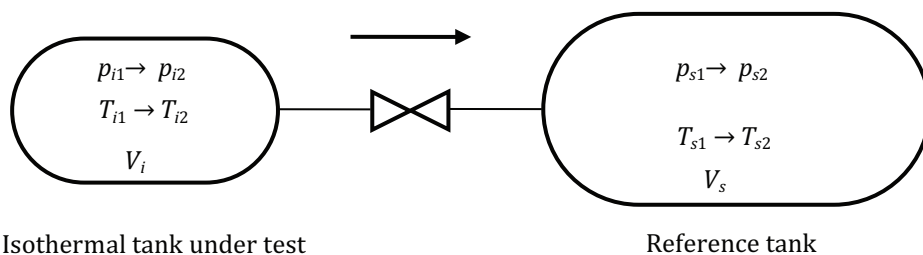

Condition	Measured result		Calculated result
	Isothermal tank under test	Reference tank	
Initial condition	$p_{i1}=789,88 \text{ kPa}$ (7,898 8 bar) $T_{i1}=300,8 \text{ K}$	$p_{s1}=100,90 \text{ kPa}$ (1,009 bar) $T_{s1}=299,9 \text{ K}$	
After discharging	$p_{i2}=220,32 \text{ kPa}$ (2,203 2 bar) $T_{i2}=298,5 \text{ K}$	$p_{s2}=220,37 \text{ kPa}$ (2,203 7 bar) $T_{s2}=300,5 \text{ K}$	$V_i=21,38 \text{ dm}^3$

$V_s = 101,67 \text{ dm}^3$

Atmospheric pressure = 100,836 kPa (1,008 36 bar)

Figure B.2 — Example of test result (discharge from Isothermal tank under test to reference tank)

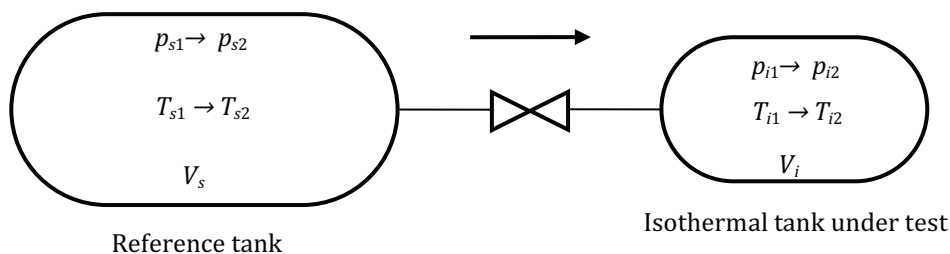

Condition	Measured result		Calculated result
	Reference tank	Isothermal tank under test	
Initial condition	$p_{s1}=655,07 \text{ kPa}$ (6,550 7 bar) $T_{s1}=301,2 \text{ K}$	$p_{i1}=100,97 \text{ kPa}$ (1,009 7 bar) $T_{i1}=299 \text{ K}$	
After discharging	$p_{s2}=557,56 \text{ kPa}$ (5,575 6 bar) $T_{s2}=300,4 \text{ K}$	$p_{i2}=557,52 \text{ kPa}$ (5,575 2 bar) $T_{i2}=300,8 \text{ K}$	$V_i=21,38 \text{ dm}^3$

$V_s = 101,67 \text{ dm}^3$

Atmospheric pressure = 100,860 kPa (1,008 6 bar)

Figure B.3 — Example of test result (discharge from reference tank to isothermal tank under test)

Table B.1 — Example of calculation of uncertainty

Input quantities						Evaluation of measurement uncertainty of the volume		
Measured value			Accuracy					
V_s	101,67	dm ³	$\pm\Delta V_s$	$\pm 0,1$	dm ³	$\partial f / \partial V_s$	0,210	
p_{s1}	100,90	kPa	$\pm\Delta p_s$	± 1	kPa	$\partial f / \partial p_{s1}$	-0,180	dm ³ /kPa
p_{s2}	220,37	kPa				$\partial f / \partial p_{s2}$	0,179	dm ³ /kPa
p_{i1}	789,88	kPa				$\partial f / \partial p_{i1}$	-0,038	dm ³ /kPa
p_{i2}	220,32	kPa				$\partial f / \partial p_{i2}$	0,038	dm ³ /kPa
T_{s1}	299,9	K	$\pm\Delta T_s$	± 1	K	$\partial f / \partial T_{s1}$	0,060	dm ³ /K
T_{s2}	300,5	K				$\partial f / \partial T_{s2}$	-0,131	dm ³ /K
T_{i1}	300,8	K				$\partial f / \partial T_{i1}$	0,099	dm ³ /K
T_{i2}	298,5	K				$\partial f / \partial T_{i2}$	-0,028	dm ³ /K
						ΔV_i	0,774	dm ³
						$\Delta V_i \%$	3,621 %	

Annex C (informative)

Isothermal tank stuffing

C.1 General

The temperature change in the tank during charging and discharging the air can be regulated by stuffing the tank with material that has a large heat capacity. This allows the test conditions to be kept constant, and the sonic conductance can be calculated by using a simple equation. Also, this allows the stabilizing time of the temperature in the tank to be reduced, which results in shorter testing time.

C.2 Mass density and isothermal performance of stuffed material

[Figure C.1](#) shows the test results for temperature drop in tanks with inside volumes of 10, 20, 50, and 100 dm³, respectively, by changing the volume of stuffed material, in this case, copper wire with a diameter of 50 µm. The figure shows how the temperature drops in the respective tank sizes with a charge pressure of 700 kPa (7 bar) during air release for approximately 15 s, which means a maximum rate of pressure drop of approximately 100 kPa/s (1 bar/s). [Table C.1](#) shows test results for a tank volume of 5 dm³; the values of the heat capacity of copper wire and air and the ratio between the values have been calculated and given for reference only. In order to maintain the temperature drop within 3 K, use of a stuffed material with a mass density of 0,3 kg/dm³ or more is necessary.

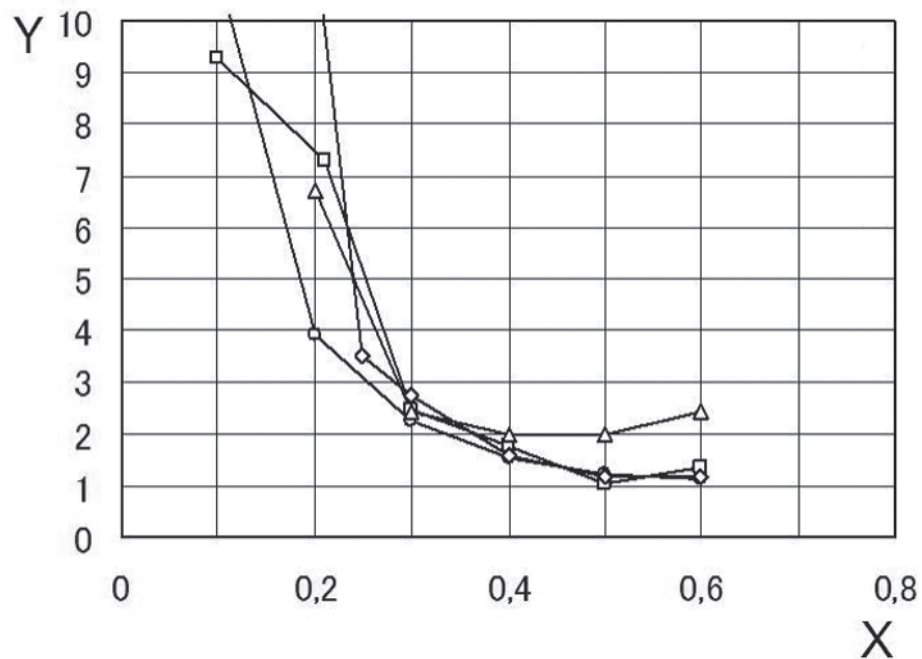

Key

- X stuffed mass [kg/dm³]
- Y temperature drop [K]
- tank volume 10 dm³
- tank volume 20 dm³
- △ tank volume 50 dm³
- ◇ tank volume 100 dm³

Figure C.1 — Influence of the mass of stuffed material on temperature drop

Table C.1 — Temperature drop with copper wire stuffed material

Mass density of copper wire stuffed material [kg/dm ³]	Percentage of stuffed volume [%]	Heat capacity of copper wire [J/K]	Heat capacity of air (at 700kPa) [J/K]	Ratio of heat capacities of copper and air	Temperature drop [K]
0,399	4,47 %	770,0	39,86	19,3	1,3
0,349	3,91 %	673,8	40,09	16,8	1,9
0,299	3,35 %	577,5	40,33	14,3	2,5
0,250	2,79 %	481,3	40,56	11,9	3,0
0,200	2,24 %	385,0	40,79	9,4	5,5
0,150	1,68 %	288,8	41,02	7,0	7,7
0,100	1,12 %	192,5	41,26	4,7	15,4
0,050	0,56 %	96,3	41,49	2,3	28,5
0,000	0,00 %	0,0	41,72	0,0	45,8

C.3 Stuffed material

C.3.1 [Table C.2](#) shows the temperature drop when the test is conducted with 4 kg of copper wire and stainless steel wire with diameters of, respectively, 30 and 50 µm stuffed at 0,40 kg/dm³ in a tank with an inside volume of 10 dm³. The test is conducted under the same conditions as above.

Table C.2 — Temperature drop with metallic wire

Wire material	Wire diameter	
	30 µm	50 µm
Copper	1,5 K	1,8 K
Stainless steel	—	1,1 K

C.3.2 [Table C.3](#) shows the temperature drop when the test is conducted with polyester fibre with diameter of 20 to 50 µm stuffed into a tank with a volume of 5 dm³. When the density of the stuffed material is 0,04 kg/dm³ or more, the temperature drop will be 3 K or less.

Table C.3 — Temperature drop with polyester fibre

Mass density of stuffed material [kg/dm ³]	Percentage of stuffed volume [%]	Heat capacity of polyester fibre [J/K]	Heat capacity of air (at 700 kPa) [J/K]	Ratio of heat capacities of fibre and air	Temperature drop [K]
0,08	5,8 %	537,6	39,31	13,7	1,5
0,04	2,9 %	268,8	40,52	6,6	2,3
0,02	1,5 %	134,4	41,12	3,3	6,2
0,00	0,0 %	0,0	41,72	0,0	45,8

C.3.3 Pellets made of materials such as porous glass or ceramic may also be used as stuffed material.

Annex D (informative)

Test method to determine isothermal performance

D.1 Purpose

The purpose of this test is to determine if the isothermal tank and its stuffing material keep the temperature of the gas from changing by more than 3 K.

D.2 Test circuit

The test circuit shown in [Figure 1](#) shall be used. In addition, a timer that is capable of setting times for opening and closing the solenoid valve shall be installed.

NOTE The sonic conductance of the component under test and volume of the tank shall be determined in accordance with Formula (1) in [5.4.3](#).

D.3 Test procedure

D.3.1 Set the initial tank pressure at 700 kPa (7 bar) using the pressure regulator (item 2) and leave the tank in this state until the temperature and pressure in the tank reach the steady-state condition.

D.3.2 Close the shut-off valve (item 3) and measure the initial pressure, p_{i1} , using the pressure transducer (item 16) and initial temperature, T_{i1} , using the temperature measuring instrument (item 5) in the tank (item 4).

D.3.3 Open the solenoid valve (item 13) for 0,5 s using the electrical control mechanism. Detect pressure change during discharge and return to the steady-state condition in the tank (item 4) using the pressure transducer (item 16), and record it using the digital recorder (item 15) as shown in [Figure D.1](#).

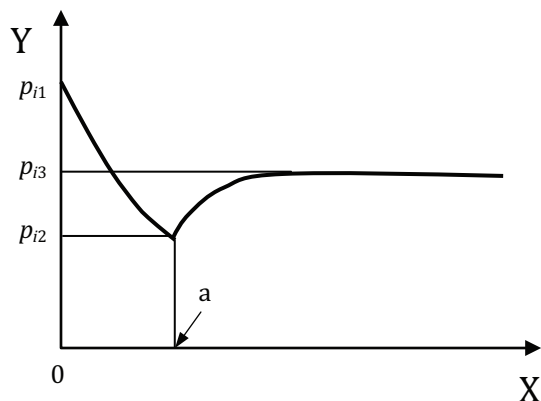

Key

X time

Y pressure

a time on valve closed

Figure D.1 — Pressure response when stopping discharge

D.3.4 After the discharge, allow sufficient time for the pressure in tank (item 4) to reach a steady-state level. Then, record the stabilized pressure, p_{i3} , and the pressure, p_{i2} , when the solenoid valve (item 13) is closed.

D.3.5 Use Formula (D.1), which is based on Charles' Law, to calculate the average temperature, T_{i2} , in the tank at the time of closing the solenoid valve:

$$T_{i2} = T_{i1} \frac{p_{i2}}{p_{i3}} \tag{D.1}$$

where

T_{i1} is the initial temperature, in K;

p_{i2} is the pressure when the solenoid valve is closed, in kPa; and

p_{i3} is the stabilized pressure, in kPa.

D.3.6 Increase the opening time of the solenoid valve by 0,5 s (i.e. to 1 s) as stated in D.3.3, and repeat D.3.1 through D.3.5 until the pressure in the tank is completely discharged.

D.4 Confirmation of isothermalization

Plot the average temperature in the tank obtained in D.3.5 in graphical form. [Figure D.2](#) shows the example described from [Table C.2](#). A temperature drop within 3 K produces a maximum deviation of 0,5 % in the conductance, C_e . Thus, if the temperature drop is within 3 K, the tank volume can be considered as an isothermal volume.

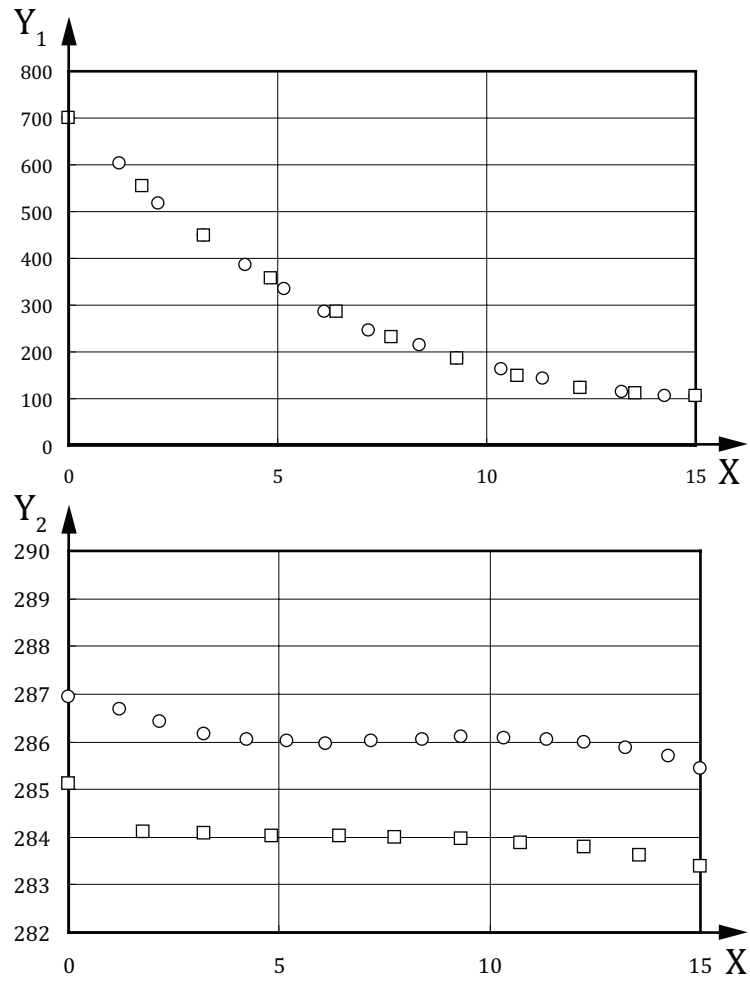

Key

- X time [s]
- Y₁ pressure [kPa]
- Y₂ temperature [K]
- wire diameter 30 μm
- wire diameter 50 μm

Figure D.2 — Influence of wire diameter on isothermal performance

Annex E (informative)

Equations for calculation of flow-rate characteristics

E.1 Equations for discharge test

E.1.1 Calculation model

Consider [Figure E.1](#) as a model of the test circuit in [Figure 1](#). The pressures in a discharge process are shown in [Figure 4](#). The volume of the upstream pressure-measuring tube has been ignored because it is much smaller than the volume of the tank. Because the temperature in the isothermal tank is nearly constant during discharge, the change of state of the air can be considered isothermal. The mass flow rate through the component under test, q_m , can be calculated using Formula (E.1), based on the equation of state:

$$q_m = -\frac{V}{RT_3} \frac{dp_3}{dt} \quad (\text{E.1})$$

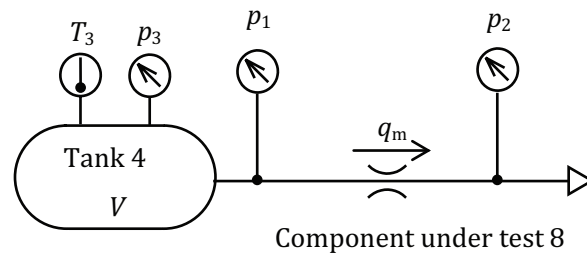

Figure E.1 — Model of discharge test circuit

E.1.2 Calculation of mass flow rate, q_m

The mass flow rate of the component under test, q_m , throughout the entire discharge regime is expressed by Formula (E.2):

$$q_m = C_e \rho_0 p_1 \sqrt{\frac{T_0}{T_3}} \quad (\text{E.2})$$

where

C_e is the conductance of the component under test.

By solving Formulae (E.1) and (E.2), the conductance, C_e , is expressed by Formula (E.3):

$$C_e = -\frac{V}{p_1 R \rho_0 \sqrt{T_0 T_3}} \frac{dp_3}{dt} \quad (\text{E.3})$$

Formula (5) in [6.3.1.2](#) for calculating the conductance, C_e , for the discharge test is obtained by modifying Formula (E.3) by the central difference method. The sonic conductance, C , is calculated from the saturated region of the conductance, C_e , as shown in [Figure 7](#).

E.1.3 Calculation of critical back-pressure ratio, b , and subsonic index, m

Formula (E.5) for conductance ratio in subsonic flow is obtained from Formulae (E.4) for mass flow rate in subsonic flow region and (E.2). Critical back-pressure ratio, b , and subsonic index, m , are calculated from the ratio of conductance, C_e , and sonic conductance, C , except in the saturated region, using Formula (E.5) and the least-square method.

$$q_m = C\rho_0 p_1 \sqrt{\frac{T_0}{T_3}} \left\{ 1 - \left(\frac{p_2 - b}{p_1 - b} \right)^2 \right\}^m \quad (\text{E.4})$$

$$\frac{C_e}{C} = \left\{ 1 - \left(\frac{p_2 - b}{p_1 - b} \right)^2 \right\}^m \quad (\text{E.5})$$

E.2 Equations for charge test

E.2.1 Calculation model

Consider [Figure E.2](#) as a model of the test circuit in [Figure 2](#). The pressures in a charge process are shown in [Figure 5](#). The volume of the downstream pressure-measuring tube has been ignored because it is much smaller than the volume of the tank. Because the temperature in the isothermal tank is nearly constant during charge, the change of state of air can be considered isothermal. The mass flow rate through the component under test, q_m , can be calculated using Formula (E.6), based on the equation of state:

$$q_m = \frac{V}{RT_3} \frac{dp_3}{dt} \quad (\text{E.6})$$

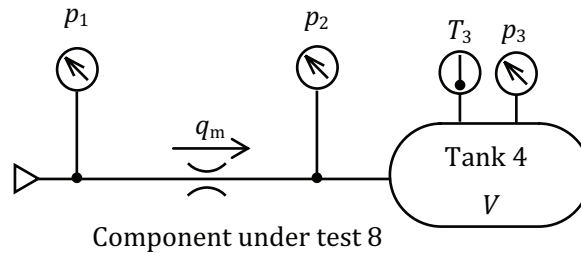

Figure E.2 — Model of charge test circuit

E.2.2 Calculation of mass flow rate, q_m

The mass flow rate of the component under test, q_m , throughout the entire charge region is expressed by Formula (E.7)

$$q_m = C_e \rho_0 p_1 \sqrt{\frac{T_0}{T_a}} \quad (\text{E.7})$$

where

C_e is the conductance of the component under test, and

T_a is the atmospheric temperature.

Consider that the temperature in the tank, T_3 , is the same as the atmospheric temperature, T_a . By solving Formulae (E.6) and (E.7), the conductance, C_e , is expressed by Formula (E.8):

$$C_e = \frac{V}{p_1 R \rho_0 \sqrt{T_0 T_3}} \frac{dp_3}{dt} \quad (\text{E.8})$$

Formula (6) in 6.3.1.2 for calculating the conductance, C_e , for charge test is obtained by modifying Formula (E.8) by the central difference method. The sonic conductance, C , is calculated from the saturated region of the conductance, C_e , as shown in [Figure 8](#).

E.2.3 Calculation of critical back-pressure ratio, b , and subsonic index, m

Formula (E.10) for the conductance ratio in subsonic flow is obtained from Formula (E.9) for mass flow rate in subsonic flow region and Formula (E.7). Critical back-pressure ratio, b , and subsonic index, m , are calculated from the ratio of the conductance, C_e , and sonic conductance, C , except in the saturated region, using Formula (E.10) and the least-square method.

$$q_m = C \rho_0 p_1 \sqrt{\frac{T_0}{T_a}} \left\{ 1 - \left(\frac{p_2 - b}{p_1 - b} \right)^2 \right\}^m \quad (\text{E.9})$$

$$\frac{C_e}{C} = \left\{ 1 - \left(\frac{p_2 - b}{p_1 - b} \right)^2 \right\}^m \quad (\text{E.10})$$

Annex F (informative)

Procedures for calculating critical back-pressure ratio, b , and subsonic index, m , by the least-square method using the Solver function in Microsoft Excel

F.1 Using data in the subsonic flow region

Critical back-pressure ratio, b , and subsonic index, m , are calculated by the least-square method using Equation (F.1), pressure ratio, $x_i = p_2/p_1$ and conductance ratio, $y_i = C_e/C$. N points are measured in the subsonic flow region, as shown in [Table F.1](#).

Table F.1 — Pressure and conductance ratios in the subsonic flow region

Measured value	
p_2/p_1	C_e/C
x_1	y_1
x_2	y_2
\vdots	\vdots
x_N	y_N

$$\frac{C_e}{C} = \left\{ 1 - \left(\frac{x_i - b}{1 - b} \right)^2 \right\}^m \quad (\text{F.1})$$

Determine b and m so that the total sum, E [see Equation (F.3)], becomes the least of the squared difference, δ_i [see Equation (F.2)] between conductance ratio, C_e/C , or $\left[1 - \left\{ (x_i - b) / (1 - b) \right\}^2 \right]^m$, calculated by substituting the measured pressure ratio, x_i , in Equation (F.1), and conductance ratio, y_i , obtained in [6.3.1.2](#) and [6.3.1.3](#). An example calculation is shown in F.2.

$$\delta_i = y_i - \left\{ 1 - \left(\frac{x_i - b}{1 - b} \right)^2 \right\}^m \quad (\text{F.2})$$

$$E = \sum_{i=1}^N \delta_i^2 = \left[y_1 - \left\{ 1 - \left(\frac{x_1 - b}{1 - b} \right)^2 \right\}^m \right]^2 + \left[y_2 - \left\{ 1 - \left(\frac{x_2 - b}{1 - b} \right)^2 \right\}^m \right]^2 + \dots + \left[y_N - \left\{ 1 - \left(\frac{x_N - b}{1 - b} \right)^2 \right\}^m \right]^2 \quad (\text{F.3})$$

F.2 Using the Solver function built in Microsoft Excel

F.2.1 Function

Solver is a function available in the software program Microsoft Excel. Using assumed initial values for the variables to be calculated, the Solver function varies these initial values in the base equation to give a best fit to the data entered for the base equation.

F.2.2 Calculation of critical back-pressure ratio, b , and subsonic index, m

F.2.2.1 Enter the values of pressure ratio, p_2/p_1 , and conductance ratio, C_e/C , in [Table F.1](#) in the cells from C4 and D4 until the end of the data (see [Figure F.1](#)). Enter Equation (F.2) in the cells from E4 until the end of the data to calculate the difference between the measured conductance ratio and calculated conductance ratio. Enter the squared column E in the cells from F4 until the end of the data to calculate the squared difference. Enter Equation (F.3) in the target cell G4 to calculate the total sum of the squared difference. The values of b (in cell A4) and m (in cell B4) are considered solved when the value in target cell G4 becomes the minimum. A value of 0,5 is entered both for b in cell A4 and for m in cell B4 as initial values.

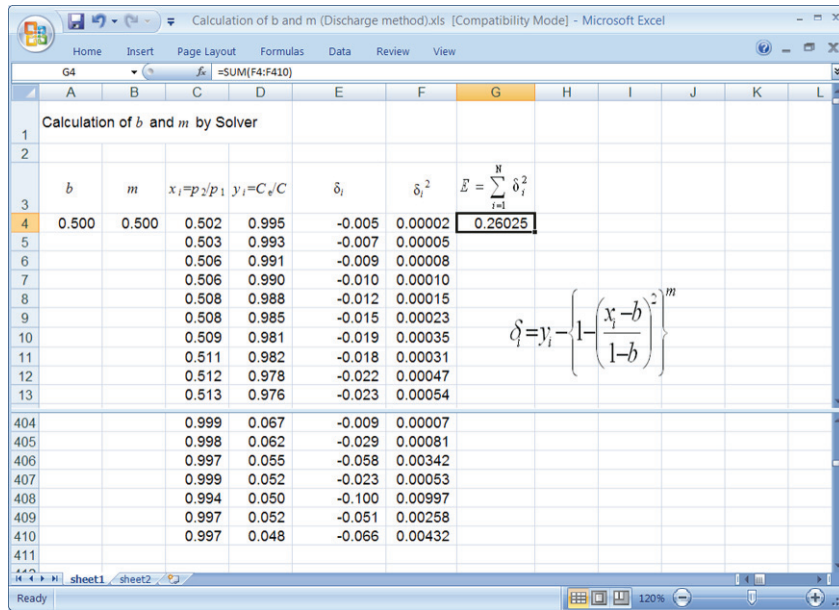
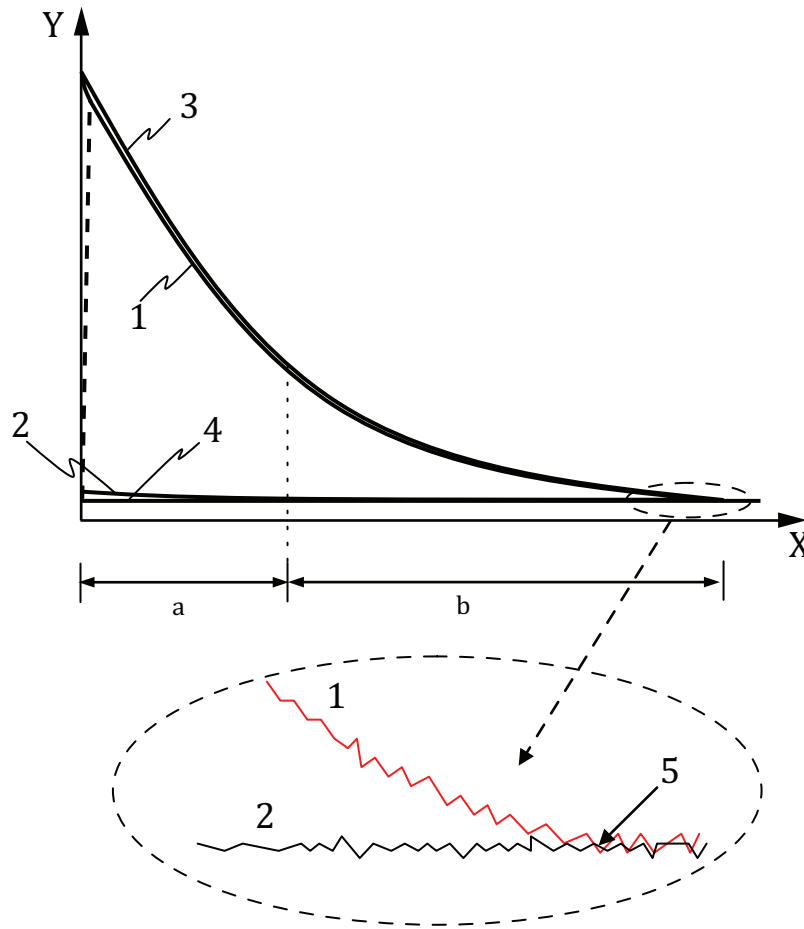

Figure F.1 — Input of data

Pressure data in the region close to the atmospheric pressure level could result in pressure ratios greater than 1 because of pressure sensor errors and signal noise, as shown in [Figure F.2](#). Data that result in pressure ratios greater than 1 can be ignored.



Key

- X time
- Y pressure
- 1 upstream pressure
- 2 downstream pressure
- 3 pressure in the tank
- 4 atmospheric pressure
- 5 crossing
- a choked flow region
- b subsonic flow region

Figure F.2 — Illustration of the possibility of pressure crossing near atmospheric conditions

F.2.2.2 Start Solver (see [Figure F.3](#)) as follows:

- a) go to Tool (T) and select Solver (V). If the “Tool (T)” menu does not display the “Solver” command, consult “Help (H)” in Excel to install the Solver to Excel; then
- b) specify the target cell G4, the target value (minimum value), and the cells for variables (A4 and B4) on the “Solver Parameter” screen and click “Solve (S)”, as shown in [Figure F.3](#).

F.2.2.3 The values in cells A4 and B4 are varied (see [Figure F.4](#)), and the values of b and m are obtained.

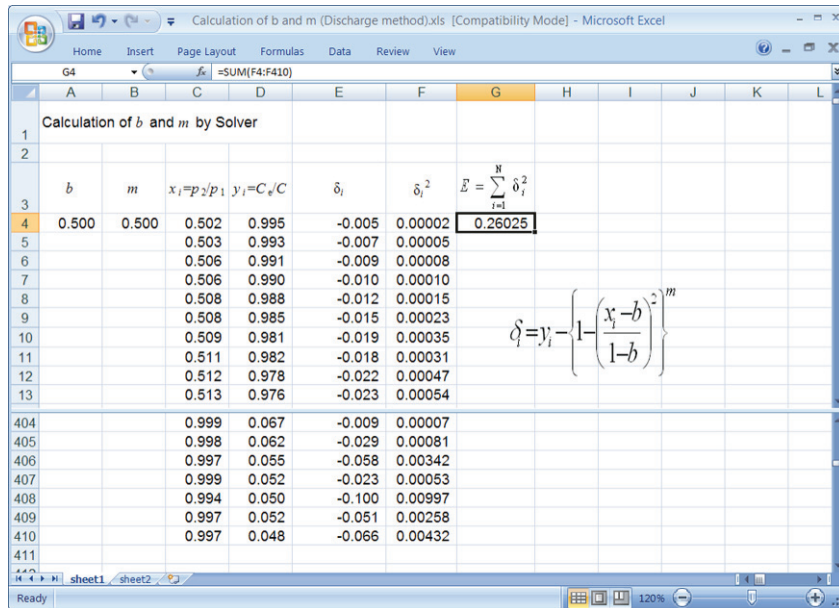

Figure F.3 — Start of Solver

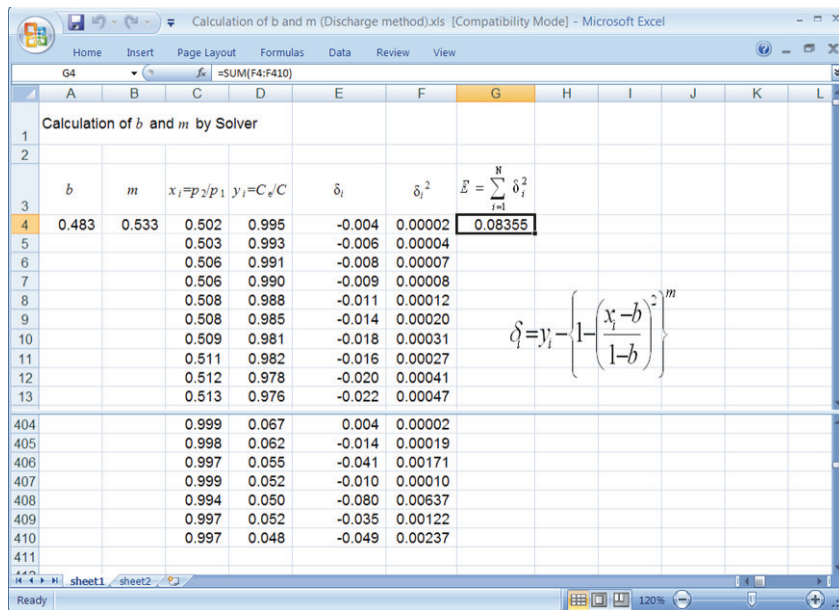

Figure F.4 — Calculation of *b* and *m*

Bibliography

- [1] ISO 5725-2, *Accuracy (trueness and precision) of measurement methods and results — Part 2: Basic method for the determination of repeatability and reproducibility of a standard measurement method*
- [2] ISO 21748, *Guidance for the use of repeatability, reproducibility and trueness estimates in measurement uncertainty estimation*

British Standards Institution (BSI)

BSI is the national body responsible for preparing British Standards and other standards-related publications, information and services.

BSI is incorporated by Royal Charter. British Standards and other standardization products are published by BSI Standards Limited.

About us

We bring together business, industry, government, consumers, innovators and others to shape their combined experience and expertise into standards-based solutions.

The knowledge embodied in our standards has been carefully assembled in a dependable format and refined through our open consultation process. Organizations of all sizes and across all sectors choose standards to help them achieve their goals.

Information on standards

We can provide you with the knowledge that your organization needs to succeed. Find out more about British Standards by visiting our website at bsigroup.com/standards or contacting our Customer Services team or Knowledge Centre.

Buying standards

You can buy and download PDF versions of BSI publications, including British and adopted European and international standards, through our website at bsigroup.com/shop, where hard copies can also be purchased.

If you need international and foreign standards from other Standards Development Organizations, hard copies can be ordered from our Customer Services team.

Subscriptions

Our range of subscription services are designed to make using standards easier for you. For further information on our subscription products go to bsigroup.com/subscriptions.

With **British Standards Online (BSOL)** you'll have instant access to over 55,000 British and adopted European and international standards from your desktop. It's available 24/7 and is refreshed daily so you'll always be up to date.

You can keep in touch with standards developments and receive substantial discounts on the purchase price of standards, both in single copy and subscription format, by becoming a **BSI Subscribing Member**.

PLUS is an updating service exclusive to BSI Subscribing Members. You will automatically receive the latest hard copy of your standards when they're revised or replaced.

To find out more about becoming a BSI Subscribing Member and the benefits of membership, please visit bsigroup.com/shop.

With a **Multi-User Network Licence (MUNL)** you are able to host standards publications on your intranet. Licences can cover as few or as many users as you wish. With updates supplied as soon as they're available, you can be sure your documentation is current. For further information, email bsmusales@bsigroup.com.

BSI Group Headquarters

389 Chiswick High Road London W4 4AL UK

Revisions

Our British Standards and other publications are updated by amendment or revision.

We continually improve the quality of our products and services to benefit your business. If you find an inaccuracy or ambiguity within a British Standard or other BSI publication please inform the Knowledge Centre.

Copyright

All the data, software and documentation set out in all British Standards and other BSI publications are the property of and copyrighted by BSI, or some person or entity that owns copyright in the information used (such as the international standardization bodies) and has formally licensed such information to BSI for commercial publication and use. Except as permitted under the Copyright, Designs and Patents Act 1988 no extract may be reproduced, stored in a retrieval system or transmitted in any form or by any means – electronic, photocopying, recording or otherwise – without prior written permission from BSI. Details and advice can be obtained from the Copyright & Licensing Department.

Useful Contacts:

Customer Services

Tel: +44 845 086 9001

Email (orders): orders@bsigroup.com

Email (enquiries): cservices@bsigroup.com

Subscriptions

Tel: +44 845 086 9001

Email: subscriptions@bsigroup.com

Knowledge Centre

Tel: +44 20 8996 7004

Email: knowledgecentre@bsigroup.com

Copyright & Licensing

Tel: +44 20 8996 7070

Email: copyright@bsigroup.com



...making excellence a habit.™