

BS ISO 6195:2013



BSI Standards Publication

Fluid power systems and components — Cylinder-rod wiper-ring housings in reciprocating applications — Dimensions and tolerances

bsi.

...making excellence a habit.™

National foreword

This British Standard is the UK implementation of ISO 6195:2013. It supersedes BS ISO 6195:2002 which is withdrawn.

The UK participation in its preparation was entrusted to Technical Committee MCE/11, Fluid seals and their housings.

A list of organizations represented on this committee can be obtained on request to its secretary.

This publication does not purport to include all the necessary provisions of a contract. Users are responsible for its correct application.

© The British Standards Institution 2013.
Published by BSI Standards Limited 2013

ISBN 978 0 580 68506 4

ICS 23.100.20

Compliance with a British Standard cannot confer immunity from legal obligations.

This British Standard was published under the authority of the Standards Policy and Strategy Committee on 31 March 2013.

Amendments issued since publication

Date	Text affected
------	---------------

INTERNATIONAL
STANDARD

ISO
6195

Third edition
2013-02-15

**Fluid power systems and components —
Cylinder-rod wiper-ring housings
in reciprocating applications —
Dimensions and tolerances**

*Transmissions hydrauliques et pneumatiques — Logements de joints
racleurs pour tiges de piston à mouvement linéaire de vérins —
Dimensions et tolérances*



Reference number
ISO 6195:2013(E)

© ISO 2013



COPYRIGHT PROTECTED DOCUMENT

© ISO 2013

All rights reserved. Unless otherwise specified, no part of this publication may be reproduced or utilized otherwise in any form or by any means, electronic or mechanical, including photocopying, or posting on the internet or an intranet, without prior written permission. Permission can be requested from either ISO at the address below or ISO's member body in the country of the requester.

ISO copyright office
Case postale 56 • CH-1211 Geneva 20
Tel. + 41 22 749 01 11
Fax + 41 22 749 09 47
E-mail copyright@iso.org
Web www.iso.org

Published in Switzerland

Contents

	Page
Foreword	iv
Introduction	v
1 Scope	1
2 Normative references	2
3 Terms and definitions	2
4 Letter symbols	2
5 General	3
6 Requirements for housings	3
6.1 Type A housing.....	3
6.2 Type B housing.....	5
6.3 Type C housing.....	7
6.4 Type D housing.....	9
6.5 Type E housing.....	12
7 Other requirements regarding dimensions	14
8 Surface roughness	14
9 Identification statement (reference to this International Standard)	15
Bibliography	16

Foreword

ISO (the International Organization for Standardization) is a worldwide federation of national standards bodies (ISO member bodies). The work of preparing International Standards is normally carried out through ISO technical committees. Each member body interested in a subject for which a technical committee has been established has the right to be represented on that committee. International organizations, governmental and non-governmental, in liaison with ISO, also take part in the work. ISO collaborates closely with the International Electrotechnical Commission (IEC) on all matters of electrotechnical standardization.

International Standards are drafted in accordance with the rules given in the ISO/IEC Directives, Part 2.

The main task of technical committees is to prepare International Standards. Draft International Standards adopted by the technical committees are circulated to the member bodies for voting. Publication as an International Standard requires approval by at least 75 % of the member bodies casting a vote.

Attention is drawn to the possibility that some of the elements of this document may be the subject of patent rights. ISO shall not be held responsible for identifying any or all such patent rights.

ISO 6195 was prepared by Technical Committee ISO/TC 131, *Fluid power systems*, Subcommittee SC 7, *Sealing devices*.

This third edition cancels and replaces the second edition (ISO 6195:2002), which has been technically revised. The most important change is the addition of an additional type of housing design: Type E housing is specified in [6.5](#).

Introduction

In fluid power systems, power is transmitted and controlled through a fluid (liquid or gas) under pressure within an enclosed circuit. Wiper rings are used to prevent ingress of contaminants and thereby to protect the seals and bearings within the equipment.

This International Standard is one of a series of standards covering the dimensions and tolerances of housings.

Fluid power systems and components — Cylinder-rod wiper-ring housings in reciprocating applications — Dimensions and tolerances

1 Scope

This International Standard specifies dimensions and tolerances of housings for wiper rings used in reciprocating rod applications for fluid power cylinders. The range of rod diameters is from 4 mm to 360 mm.

This International Standard is applicable to the following five housing designs.

- Type A: recessed housings with undercut or separate cover to retain elastomeric wipers.
- Type B: open recessed housings for wipers with integral rigid enforcement, that are press-fit in the housing.
- Type C: recessed housings with undercut to retain elastomeric wipers (these are the preferred housings for double lip wipers without integral rigid enforcement).
- Type D: recessed housings with undercut to retain elastomer-energized, plastic-faced wipers.
- Type E: recessed housings with undercut or separate cover to retain elastomeric wipers (these are the preferred housings for single lip wipers without integral rigid enforcement).

These housing designs are intended for use with the wiper rings according to [Figure 1](#).

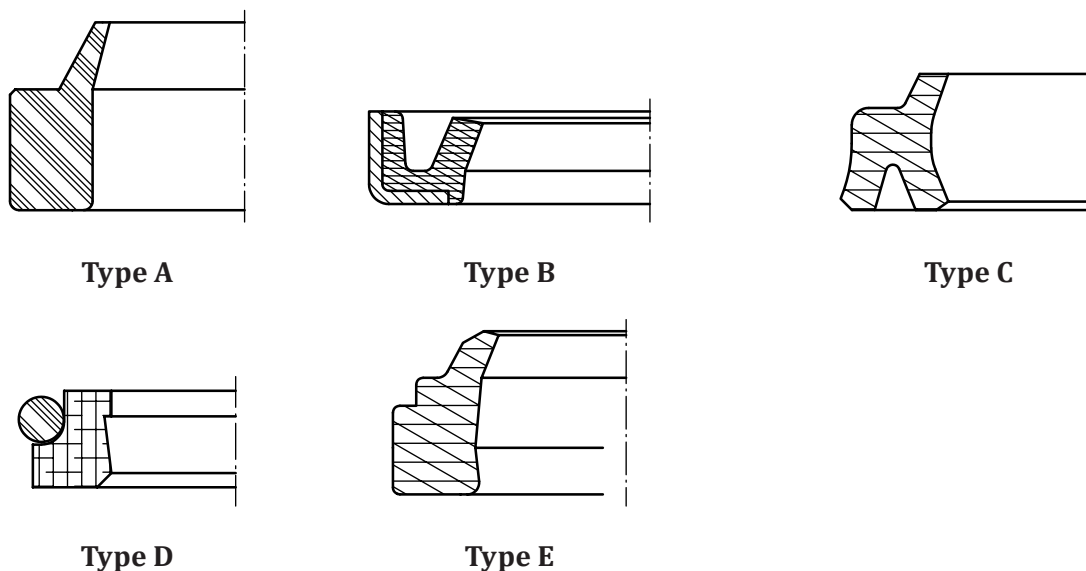

Figure 1 — Types of wiper rings

This International Standard does not otherwise specify the style, configurations, materials, or performance ratings for the wiper ring.

2 Normative references

The following referenced documents are indispensable for the application of this document. For dated references, only the edition cited applies. For undated references, the latest edition of the referenced document (including any amendments) applies.

ISO 883, *Indexable hardmetal (carbide) inserts with rounded corners, without fixing hole — Dimensions*

ISO 3320, *Fluid power systems and components— Cylinder bores and piston rod diameters— Metric series*

ISO 5597, *Hydraulic fluid power — Cylinders — Dimensions and tolerances of housings for single-acting piston and rod seals in reciprocating applications*

ISO 5598, *Fluid power systems and components — Vocabulary*

ISO 6020-1, *Hydraulic fluid power — Mounting dimensions for single rod cylinders, 16 MPa (160 bar) series — Part 1: Medium series*

ISO 6020-2, *Hydraulic fluid power — Mounting dimensions for single rod cylinders, 16 MPa (160 bar) series — Part 2: Compact series*

ISO 6020-3, *Hydraulic fluid power — Mounting dimensions for single rod cylinders, 16 MPa (160 bar) series — Part 3: Compact series with bores from 250 mm to 500 mm*

ISO 6022, *Hydraulic fluid power — Mounting dimensions for single rod cylinders, 25 MPa (250 bar) series*

ISO 10762, *Hydraulic fluid power — Cylinder mounting dimensions — 10 MPa (100 bar) series*

3 Terms and definitions

For the purposes of this document, the terms and definitions given in ISO 5598 apply.

4 Letter symbols

The letter symbols used in this International Standard are as follows:

d	rod diameter
D_1	outside diameter of wiper housing
D_2	retainer diameter
C	axial length of the lead-in chamfer
L_1	axial length of the wiper housing
L_2	maximum wiper assembly length
L_3	retainer width
$S = \frac{D_1 - d}{2}$	radial depth (cross-section) of the housing
r	radius
a	roughness of the side surface of the wiper housing

- b* roughness of the surface of the wiper housing bore
e roughness of the rod
f roughness of the leading chamfer

5 General

The wiper ring manufacturer should be consulted on the suitability of a particular type of wiper ring for the application.

Sharp edges and burrs shall be removed from corners of supporting surfaces and rounded.

Surface finishes have a significant impact on the performance and lifetime of the wipers. Recommended surface finishes are shown in [Figures 2 to 6](#) (see also [Clause 8](#) for surface roughness recommendations).

6 Requirements for housings

6.1 Type A housing

6.1.1 Type A housing and a typical wiper ring are shown in [Figure 2](#).

6.1.2 Type A housing dimensions and tolerances shall conform to [Table 1](#).

6.1.3 Type A wiper rings are recommended for use with cylinders conforming to ISO 6020-1 and to ISO 6022.

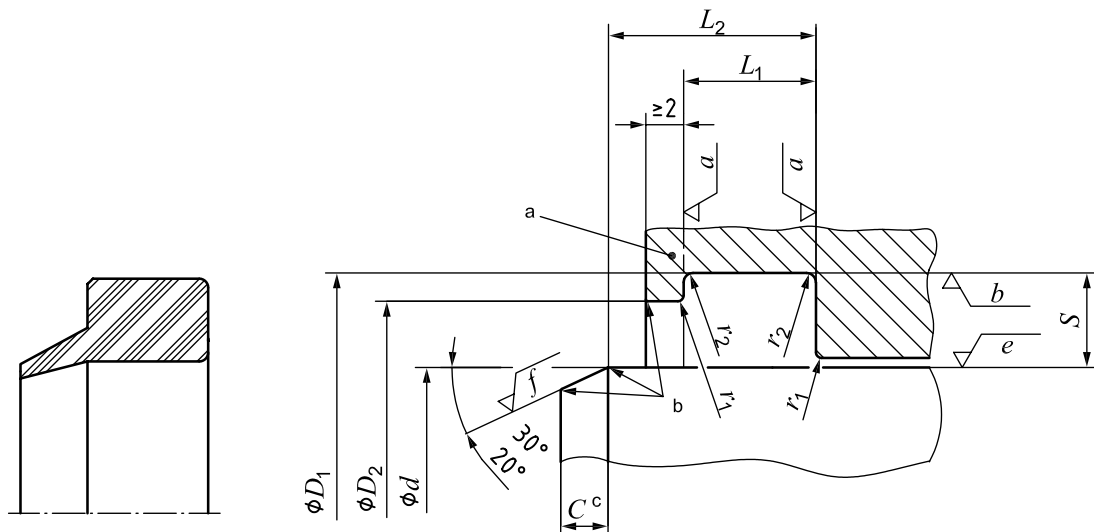

Key

- a May be integral or with separate retaining plate.
b Rounded and burr free.
c See [Table 6](#) for dimensions.

Figure 2 — Type A wiper housing and typical wiper ring

Dimensions in millimetres

Table 1 — Dimensions for type A wiper housings

Dimensions in millimetres

Rod diameter ^{a, b}	Radial depth	Outside diameter	Axial length	Wiper assembly length	Retainer diameter	Retainer radius	Radius
<i>d</i>	<i>S</i>	D_1 H11 ^d	L_1	L_2 max.	D_2 H11 ^d	r_1 max.	r_2 ^c max.
4	4,0	12	5,0 ^{+0,2} ₀	8	9,5	0,3	0,5
5		13			10,5		
6		14			11,5		
8		16			13,5		
10		18			15,5		
12		20			17,5		
14		22			19,5		
16		24			21,5		
18		26			23,5		
20		28			25,5		
22		30			27,5		
25		33			30,5		
28		36			33,5		
32		40			37,5		
36		44			41,5		
40	48	45,5					
45	53	50,5					
50	58	55,5					
56	5,0	66	6,3 ^{+0,2} ₀	10	63	0,4	
63		73			70		
70		80			77		
80		90			87		
90		100			97		
100	7,5	115	9,5 ^{+0,3} ₀	14	110	0,6	
110		125			120		
125		140			135		
140		155			150		
160		175			170		
180		195			190		
200	215	210					
220	10,0	240	12,5 ^{+0,3} ₀	18	233,5	0,8	
250		270			263,5		
280		300			293,5		
320		340			333,5		
360		380			373,5		

^a See ISO 3320 and ISO 5597.

^b One-piece housings can be used with rod diameters greater than 14 mm.

^c These specific dimensions permit the use of tools conforming to ISO 883.

^d Tolerances and fits are according to ISO 286-1.

Table 2 — Dimensions for type B wiper housings

Dimensions in millimetres

Rod diameter ^a	Radial depth	Outside diameter	Axial length	Wiper assembly length
<i>d</i>	<i>S</i>	<i>D</i> ₁ H8 ^b	<i>L</i> ₁ +0,5 0	<i>L</i> ₂ max.
4 5 6 8 10	4,0	12 13 14 16 18	5	8
12 14 16 18 20 22 28 25 32 36 40 45 50 56 63 70 80 90	5,0	22 24 26 28 30 32 38 35 42 46 50 55 60 66 73 80 90 100	7	11
100 110 125 140 160 180 200	7,5	115 125 140 155 175 195 215	9	13
220 250 280 320 360	10,0	240 270 300 340 380	12	16
^a See ISO 3320 and ISO 5597. ^b Tolerances and fits are according to ISO 286-1.				

6.3 Type C housing

6.3.1 Type C housing and a typical wiper ring are shown in [Figure 4](#).

6.3.2 Type C housing dimensions and tolerances shall conform to [Table 3](#) (the size for use with glands conforming to ISO 6020-2, to ISO 6020-3 and to ISO 10762 are indicated).

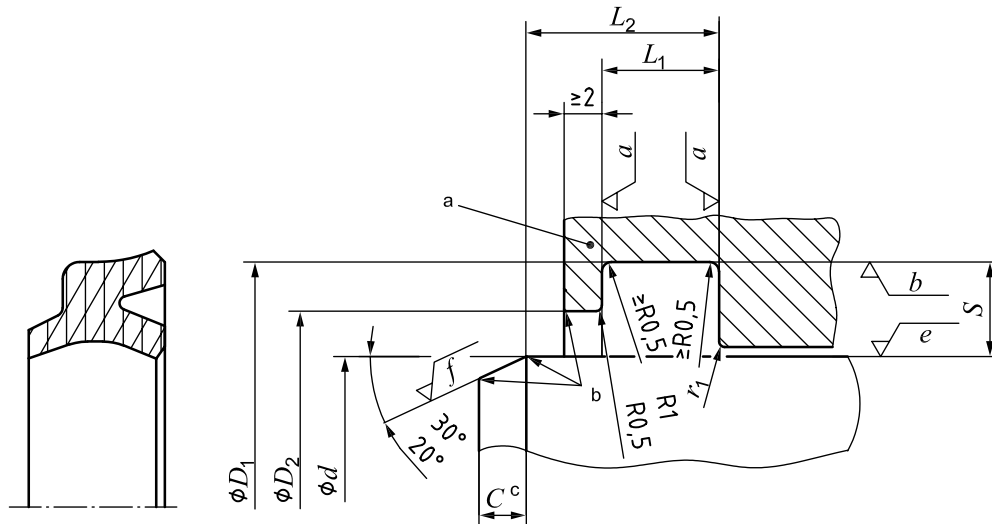

Key

- a May be integral or with separate retaining plate.
- b Rounded and burr free.
- c See [Table 6](#) for dimensions.

Figure 4 — Type C wiper housing and typical wiper ring

Dimensions in millimetres

Table 3 — Dimensions for type C wiper housings

Dimensions in millimetres

Rod diameter ^{a, b}	Radial depth	Outside diameter	Axial length	Wiper assembly length	Retainer diameter	Radius
<i>d</i>	<i>S</i>	<i>D</i> ₁ H11 ^e	<i>L</i> ₁	<i>L</i> ₂ max.	<i>D</i> ₂ H11 ^e	<i>r</i> ₁ max.
4	3,0	10	4,0 ^{+0,2} ₀	7,0	6,5	0,3
5		11			7,5	
6		12			8,5	
8		14			10,5	
10		16			12,5	
12 ^c		18			14,5	
14 ^c		20			16,5	
16		22			18,5	
18 ^c		24			20,5	
20		26			22,5	
22 ^c		28			24,5	
25	31	27,5				
28 ^c	4,0	36	5,0 ^{+0,2} ₀	8,0	31	0,3
32		40			35	
36 ^c		44			39	
40		48			43	
45 ^c		53			48	
50		58			53	
56 ^c	5,0	66	6,0 ^{+0,2} ₀	9,7	59	0,3
63		73			66	
70 ^c		80			73	
80		90			83	
90 ^c		100			93	
100		110			103	
110 ^c	7,5	125	8,5 ^{+0,3} ₀	13,0	114	0,4
125		140			129	
140 ^{c, d}		155			144	
160		175			164	
180 ^d		195			184	
200		215			204	
220 ^d	10,0	240	12,0 ^{+0,3} ₀	18,0	226	0,6
250 ^d		270			256	
280 ^d		300			286	
320		340			326	
360 ^d		380			366	

^a See ISO 3320 and ISO 5597.
^b Split-housings should be used for rod diameters up to and including 18 mm.
^c These sizes are recommended for use with cylinders conforming to ISO 6020-2 and ISO 10762.
^d These sizes are recommended for use with cylinders conforming to ISO 6020-3.
^e Tolerances and fits are according to ISO 286-1.

6.4 Type D housing

6.4.1 Type D housing and a typical wiper ring are shown in [Figure 5](#).

6.4.2 Type D housing dimensions and tolerances shall conform to [Table 4](#).

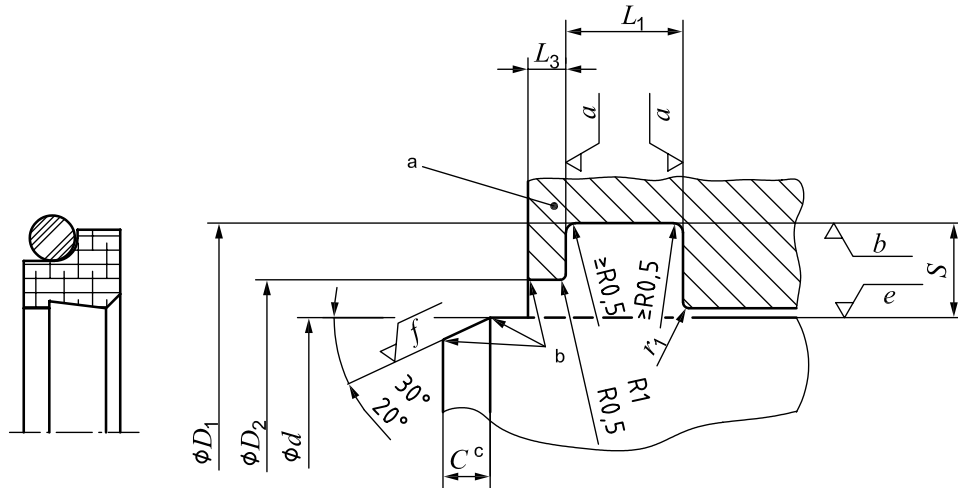

Key

- a May be integral or with separate retaining plate.
- b Rounded and burr free.
- c See [Table 6](#) for dimensions.

Figure 5 — Type D wiper housing and typical wiper ring

Dimensions in millimetres

Table 4 — Dimensions for type D wiper housings

Dimensions in millimetres

Rod diameter <i>a, b, c</i>	Radial depth	Outside diameter	Axial length	Retainer diameter	Retainer width	Radius
<i>d</i>	<i>S</i>	<i>D</i> ₁ H9 ^d	<i>L</i> ₁ +0,2 0	<i>D</i> ₂ H11 ^d	<i>L</i> ₃ min.	<i>r</i> ₁ max.
4	2,4	8,8	3,7	5,5	2,0	0,4
5		9,8		6,5		
6		10,8		7,5		
8		12,8		9,5		
10		14,8		11,5		
12	3,4	18,8	5,0	13,5		0,8
14		20,8		15,5		
16		22,8		17,5		
18		24,8		19,5		
20		26,8		21,5		
22		28,8		23,5		
25		31,8		26,5		
28		34,8		29,5		
32		38,8		33,5		
36		42,8		37,5		
40 ^c	3,4	46,8	5,0	41,5	2	0,8
	4,4	48,8	6,3		3	
45	3,4	51,8	5,0	46,5	2	
	4,4	53,8	6,3		3	
50	3,4	56,8	5,0	51,5	2	
	4,4	58,8	6,3		3	
56	3,4	62,8	5,0	57,5	2	
	4,4	64,8	6,3		3	
63	3,4	69,8	5,0	64,5	2	
	4,4	71,8	6,3		3	

^a See ISO 3320 and ISO 5597.

^b Split-housings should be used for rod diameters up to and including 28 mm.

^c From 40 mm rod diameter the smaller wiper profiles are recommended for light applications. The larger wiper profiles are recommended for heavy duty applications.

^d Tolerances and fits are according to ISO 286-1.

Table 4 (continued)

Rod diameter a, b, c	Radial depth	Outside diameter	Axial length	Retainer diameter	Retainer width	Radius
d	S	D_1 H9 ^d	L_1 +0,2 0	D_2 H11 ^d	L_3 min.	r_1 max.
70	4,4	78,8	6,3	71,5	3	1,0
	6,1	82,2	8,1	72,0	4	
80	4,4	88,8	6,3	81,5	3	
	6,1	92,2	8,1	82,0	4	
90	4,4	98,8	6,3	91,5	3	
	6,1	102,2	8,1	92,0	4	
100	4,4	108,8	6,3	101,5	3	
	6,1	112,2	8,1	102,0	4	
110	4,4	118,8	6,3	111,5	3	
	6,1	122,2	8,1	112,0	4	
125	4,4	133,8	6,3	126,5	3	
	6,1	137,2	8,1	127,0	4	
140	6,1	152,2	8,1	142,0	4	
	8,0	156,0	9,5	142,5	5	
160	6,1	172,2	8,1	162,0	4	1,0
	8,0	176,0	9,5	162,5	5	1,5
180	6,1	192,2	8,1	182,0	4	1,0
	8,0	196,0	9,5	182,5	5	1,5
200	6,1	212,2	8,1	202,0	4	1,0
	8,0	216,0	9,5	202,5	5	1,5
220	6,1	232,2	8,1	222,0	4	1,0
	8,0	236,0	9,5	222,5	5	1,5
250	6,1	262,2	8,1	252,0	4	1,0
	8,0	266,0	9,5	252,5	5	1,5
280	6,1	292,2	8,1	282,0	4	
	8,0	296,0	9,5	282,5	5	
320	6,1	332,2	8,1	322,0	4	
	8,0	336,0	9,5	322,5	5	
360	6,1	372,2	8,1	362,0	4	
	8,0	376,0	9,5	362,5	5	

a See ISO 3320 and ISO 5597.

b Split-housings should be used for rod diameters up to and including 28 mm.

c From 40 mm rod diameter the smaller wiper profiles are recommended for light applications. The larger wiper profiles are recommended for heavy duty applications.

d Tolerances and fits are according to ISO 286-1.

6.5 Type E housing

6.5.1 Type E housing and a typical wiper ring are shown in [Figure 6](#).

6.5.2 Type E housing dimensions and tolerances shall conform to [Table 5](#).

6.5.3 Type E wiper rings are recommended for use with cylinders conforming to ISO 6020-1 and to ISO 6022.

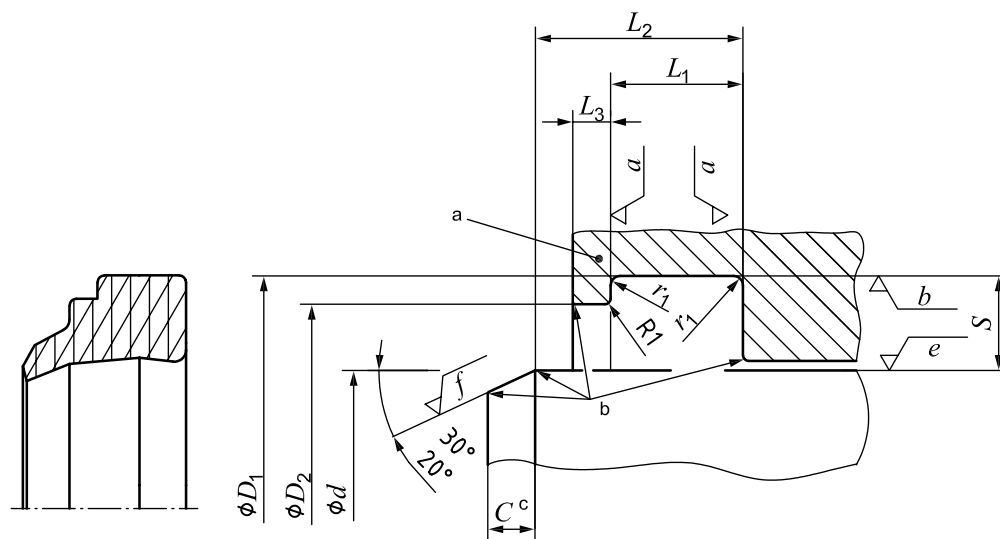

Key

- a May be integral or with separate retaining plate.
- b Rounded and burr free.
- c See [Table 6](#) for dimensions.

Figure 6 — Type E wiper housing and typical wiper ring

Dimensions in millimetres

Table 5 — Dimensions for type E wiper housings

Dimensions in millimetres

Rod diameter a, b	Radial depth	Outside diameter	Axial length	Wiper assembly length	Retainer width	Retainer diameter	Radius
d f8 c	S	D_1 H11 c	L_1 +0,15 0	L_2 max.	L_3 min.	D_2 H11 c	r_1 max.
8	4,0	16	4,0	7	1,0	14	0,2
10		18				16	
12		20				18	
14		22				20	
16		24				22	
18		26				24	
20		28				26	
22		30				28	
25		33				31	
28		36				34	
32		40				38	
36		44				42	
40		48				46	
45		53				51	
50		58				56	
56		64				62	
63		71				69	
70	78	76					
80	88	86					
90	6,0	102	5,5	10	1,5	99	0,3
100		112				109	
110		122				119	
125		137				134	
140		152				149	
160		172				169	
180		192				189	
200		212				209	
220	7,5	235	6,5	13	2,0	231	0,5
250		265				261	
280		295				291	
320		335				331	
360		375				371	

a See ISO 3320 and ISO 5597.

b One-piece housings can be used with rod diameters greater than 14 mm.

c Tolerances and fits are according to ISO 286-1.

7 Other requirements regarding dimensions

- 7.1 Reference shall be made to [Figures 2 to 6](#) for the location of the lead-in chamfer, *C*, on the rod end.
- 7.2 The rod-end chamfer shall make an angle of between 20° and 30° with the axis.
- 7.3 The length of the rod-end chamfer shall not be less than specified in [Table 6](#).
- 7.4 The housing lead-in chamfer dimensions for type B housings shall conform to [Figure 3](#).

Table 6 — Lead-in chamfer

Dimensions in millimetres

Radial depth of housing, <i>S</i>	$S < 4,0$	$4,0 \leq S < 5,5$	$5,5 \leq S < 7,0$	$7,0 \leq S < 9,0$	$9,0 \leq S < 12,0$
Minimum axial length of lead-in chamfer, <i>C</i>	2	2,5	3,0	4,0	5,0

8 Surface roughness

- 8.1 The surface roughness of the wiper housing and any mating part has a significant impact on the life and sealing performance of the wiper.
- 8.2 Unless otherwise agreed, surface roughness values shall be in accordance with [Table 7](#).
- 8.3 Unless otherwise agreed, the material ratio, *Rmr*, should be 50 % to 80 % for surfaces of mating parts, determined at a cut depth of $C = 0,25 R_z$, relative to a reference profile line of $C_0 = 0,05 Rmr$ (see ISO 4287:1997, 4.5.2).

Table 7 — Surface roughness requirements for piston and rod housings

Dimensions in millimetres unless otherwise noted

Surface roughness values in micrometres ^{a, b, c}				Minimum required measuring length mm (five times single sampling length plus two times cut off)
Dynamic pressure mating surface ^d	Static pressure mating surface ^d	Side surface	Chamfer	
<i>e</i>	<i>b</i>	<i>a</i>	<i>f</i>	
<i>Ra</i> 0,4 <i>Rz</i> 1,6	<i>Ra</i> 1,6 <i>Rz</i> 6,3	<i>Ra</i> 4 <i>Rz</i> 16	<i>Ra</i> 4 visual inspection or <i>Rz</i> 16 visual inspection	5,6

^a Indication of surface roughness is taken from ISO 1302.

^b See ISO 13715 for design of edges and undefined shapes.

^c Special applications can require different surface roughness values.

^d Visual surface imperfections are not allowed on surfaces *b* and *e* (see ISO 8785).

9 Identification statement (reference to this International Standard)

Manufacturers are strongly recommended to use the following statement in test reports, catalogues and sales literature when electing to comply with this International Standard.

“Dimensions and tolerances for wiper-ring housings, selected in accordance with ISO 6195:2012, Fluid power systems and components — Cylinder-rod wiper-ring housings in reciprocating applications — Dimensions and tolerances.”

Bibliography

- [1] ISO 286-1, *Geometrical product specifications (GPS) — ISO code system for tolerances on linear sizes — Part 1: Basis of tolerances, deviations and fits*
- [2] ISO 286-2, *Geometrical product specifications (GPS) — ISO code system for tolerances on linear sizes — Part 2: Tables of standard tolerance classes and limit deviations for holes and shafts*
- [3] ISO 1302, *Geometrical Product Specifications (GPS) — Indication of surface texture in technical product documentation*
- [4] ISO 4287, *Geometrical Product Specifications (GPS) — Surface texture: Profile method — Terms, definitions and surface texture parameters*
- [5] ISO 8015, *Geometrical product specifications (GPS) — Fundamentals — Concepts, principles and rules*
- [6] ISO 8785, *Geometrical Product Specification (GPS) — Surface imperfections — Terms, definitions and parameters*
- [7] ISO 13715, *Technical drawings — Edges of undefined shape — Vocabulary and indications*

British Standards Institution (BSI)

BSI is the national body responsible for preparing British Standards and other standards-related publications, information and services.

BSI is incorporated by Royal Charter. British Standards and other standardization products are published by BSI Standards Limited.

About us

We bring together business, industry, government, consumers, innovators and others to shape their combined experience and expertise into standards-based solutions.

The knowledge embodied in our standards has been carefully assembled in a dependable format and refined through our open consultation process. Organizations of all sizes and across all sectors choose standards to help them achieve their goals.

Information on standards

We can provide you with the knowledge that your organization needs to succeed. Find out more about British Standards by visiting our website at bsigroup.com/standards or contacting our Customer Services team or Knowledge Centre.

Buying standards

You can buy and download PDF versions of BSI publications, including British and adopted European and international standards, through our website at bsigroup.com/shop, where hard copies can also be purchased.

If you need international and foreign standards from other Standards Development Organizations, hard copies can be ordered from our Customer Services team.

Subscriptions

Our range of subscription services are designed to make using standards easier for you. For further information on our subscription products go to bsigroup.com/subscriptions.

With **British Standards Online (BSOL)** you'll have instant access to over 55,000 British and adopted European and international standards from your desktop. It's available 24/7 and is refreshed daily so you'll always be up to date.

You can keep in touch with standards developments and receive substantial discounts on the purchase price of standards, both in single copy and subscription format, by becoming a **BSI Subscribing Member**.

PLUS is an updating service exclusive to BSI Subscribing Members. You will automatically receive the latest hard copy of your standards when they're revised or replaced.

To find out more about becoming a BSI Subscribing Member and the benefits of membership, please visit bsigroup.com/shop.

With a **Multi-User Network Licence (MUNL)** you are able to host standards publications on your intranet. Licences can cover as few or as many users as you wish. With updates supplied as soon as they're available, you can be sure your documentation is current. For further information, email bsmusales@bsigroup.com.

BSI Group Headquarters

389 Chiswick High Road London W4 4AL UK

Revisions

Our British Standards and other publications are updated by amendment or revision.

We continually improve the quality of our products and services to benefit your business. If you find an inaccuracy or ambiguity within a British Standard or other BSI publication please inform the Knowledge Centre.

Copyright

All the data, software and documentation set out in all British Standards and other BSI publications are the property of and copyrighted by BSI, or some person or entity that owns copyright in the information used (such as the international standardization bodies) and has formally licensed such information to BSI for commercial publication and use. Except as permitted under the Copyright, Designs and Patents Act 1988 no extract may be reproduced, stored in a retrieval system or transmitted in any form or by any means – electronic, photocopying, recording or otherwise – without prior written permission from BSI. Details and advice can be obtained from the Copyright & Licensing Department.

Useful Contacts:

Customer Services

Tel: +44 845 086 9001

Email (orders): orders@bsigroup.com

Email (enquiries): cservices@bsigroup.com

Subscriptions

Tel: +44 845 086 9001

Email: subscriptions@bsigroup.com

Knowledge Centre

Tel: +44 20 8996 7004

Email: knowledgecentre@bsigroup.com

Copyright & Licensing

Tel: +44 20 8996 7070

Email: copyright@bsigroup.com



...making excellence a habit.™