

**Fluid power systems
and components
— Cylinders —
Identification code for
mounting dimensions
and mounting types**

ICS 23.100.20

National foreword

This British Standard is the UK implementation of ISO 6099:2009. It supersedes BS ISO 6099:2001 which is withdrawn.

The UK participation in its preparation was entrusted to Technical Committee MCE/18/-/3, Cylinders.

A list of organizations represented on this committee can be obtained on request to its secretary.

This publication does not purport to include all the necessary provisions of a contract. Users are responsible for its correct application.

Compliance with a British Standard cannot confer immunity from legal obligations.

This British Standard was published under the authority of the Standards Policy and Strategy Committee on 30 April 2009

© BSI 2009

ISBN 978 0 580 60188 0

Amendments/corrigenda issued since publication

Date	Comments

INTERNATIONAL STANDARD

ISO
6099

Fourth edition
2009-04-01

Fluid power systems and components — Cylinders — Identification code for mounting dimensions and mounting types

*Transmissions hydrauliques et pneumatiques — Vérins — Code
d'identification des dimensions de montage et des modes de fixation*



Reference number
ISO 6099:2009(E)

PDF disclaimer

This PDF file may contain embedded typefaces. In accordance with Adobe's licensing policy, this file may be printed or viewed but shall not be edited unless the typefaces which are embedded are licensed to and installed on the computer performing the editing. In downloading this file, parties accept therein the responsibility of not infringing Adobe's licensing policy. The ISO Central Secretariat accepts no liability in this area.

Adobe is a trademark of Adobe Systems Incorporated.

Details of the software products used to create this PDF file can be found in the General Info relative to the file; the PDF-creation parameters were optimized for printing. Every care has been taken to ensure that the file is suitable for use by ISO member bodies. In the unlikely event that a problem relating to it is found, please inform the Central Secretariat at the address given below.



COPYRIGHT PROTECTED DOCUMENT

© ISO 2009

All rights reserved. Unless otherwise specified, no part of this publication may be reproduced or utilized in any form or by any means, electronic or mechanical, including photocopying and microfilm, without permission in writing from either ISO at the address below or ISO's member body in the country of the requester.

ISO copyright office
Case postale 56 • CH-1211 Geneva 20
Tel. + 41 22 749 01 11
Fax + 41 22 749 09 47
E-mail copyright@iso.org
Web www.iso.org

Published in Switzerland

Contents

Page

Foreword.....	iv
Introduction	v
1 Scope	1
2 Normative references	1
3 Terms and definitions.....	1
4 Identification code for rod end types.....	1
4.1 Reference points and letter codes	1
4.1.1 General.....	1
4.1.2 Plain rod end	2
4.1.3 Pin rod end	2
4.1.4 Female threaded rod end	2
4.1.5 Male threaded rod end.....	3
4.1.6 Wrench flat piston rod end or hook wrench holes	4
4.1.7 Flanged piston rod end — Alternative reference points.....	5
4.2 Identification code	5
5 Letter code for identifying cylinder mounting, envelope and accessory dimensions	6
5.1 General.....	6
5.2 Letter <i>Z</i>	6
5.3 Letter <i>U</i>	6
5.4 Letters <i>W, X, Y, Z</i>.....	6
5.5 Signs	6
5.6 Dimensioning	6
6 Identification code for mounting types	8
6.1 General.....	8
6.2 Mounting types	8
6.3 Letter codes of mounting and envelope dimensions according to cylinder mounting type.....	11
7 Identification code for accessory types	36
7.1 General.....	36
7.2 Accessory types	37
7.3 Letter codes of accessories according to accessory type.....	38
8 Designation of the position of the ports in round and square types	45
9 Identification statement (Reference to this International Standard)	46

Foreword

ISO (the International Organization for Standardization) is a worldwide federation of national standards bodies (ISO member bodies). The work of preparing International Standards is normally carried out through ISO technical committees. Each member body interested in a subject for which a technical committee has been established has the right to be represented on that committee. International organizations, governmental and non-governmental, in liaison with ISO, also take part in the work. ISO collaborates closely with the International Electrotechnical Commission (IEC) on all matters of electrotechnical standardization.

International Standards are drafted in accordance with the rules given in the ISO/IEC Directives, Part 2.

The main task of technical committees is to prepare International Standards. Draft International Standards adopted by the technical committees are circulated to the member bodies for voting. Publication as an International Standard requires approval by at least 75 % of the member bodies casting a vote.

Attention is drawn to the possibility that some of the elements of this document may be the subject of patent rights. ISO shall not be held responsible for identifying any or all such patent rights.

ISO 6099 was prepared by Technical Committee ISO/TC 131, *Fluid power systems*, Subcommittee SC 3, *Cylinders*.

This fourth edition cancels and replaces the third edition (ISO 6099:2001), which has been technically revised.

Introduction

In fluid power systems, power is transmitted and controlled through a fluid (liquid or gas) under pressure within an enclosed circuit. Systems and their components are generally designed and marketed for a specific fluid pressure.

One such component is the fluid power cylinder. This is a device which converts power into linear mechanical force and motion. It consists of a movable element, i.e. a piston and piston rod, operating within a cylindrical bore.

Although this International Standard provides a code and means of dimensioning for cylinder mounting, it is not intended that all dimensions be standardized. The code specified in this International Standard is not to be considered as complete for the development of future interchangeability standards. It establishes uniform descriptions for dimensions and achieves conformity of language.

The code can be used for analogous dimensions when this involves neither confusion nor misunderstanding.

Fluid power systems and components — Cylinders — Identification code for mounting dimensions and mounting types

1 Scope

This International Standard establishes a convention for the identification of mounting dimensions and types used in the mounting of fluid power cylinders. It specifies a code for identifying cylinder mounting, envelope, accessory and connector dimensions, and for cylinder mounting and accessory types.

This International Standard does not represent a standard list of all fluid power cylinder mounting and accessory types.

2 Normative references

The following referenced documents are indispensable for the application of this document. For dated references, only the edition cited applies. For undated references, the latest edition of the referenced document (including any amendments) applies.

ISO 5598, *Fluid power systems and components — Vocabulary*

3 Terms and definitions

For the purposes of this document, the terms and definitions given in ISO 5598 apply.

4 Identification code for rod end types

4.1 Reference points and letter codes

4.1.1 General

4.1.1.1 First point of reference

Axial dimensions are determined from a reference point that is the same for all cylinders, whatever their mounting method. This theoretical reference point (TRP) is the point of force transfer from the piston rod to the movable element. This point of reference (TRP) is named the first TRP.

4.1.1.2 Second point of reference

For double rod cylinders, the second TRP is defined by the letter code ZM++ directly attached to the first point of TRP (see Figure 8). This second TRP is used for accessories on the second rod side.

4.1.2 Plain rod end

For a plain rod end, the reference point is located on the rod centreline at the end of the piston rod. See Figure 1.

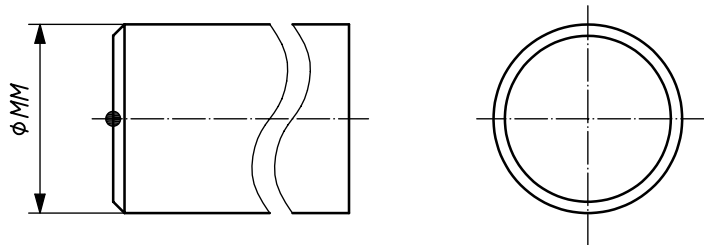

Figure 1 — RPE_x: Plain rod end

4.1.3 Pin rod end

For a pin rod end, the reference point is located at the intersection of the pin and piston rod centrelines. See Figure 2.

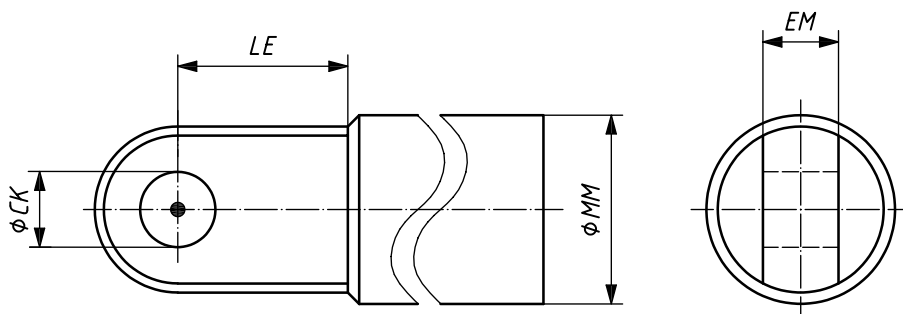

Figure 2 — RPR_x: Pin rod end

4.1.4 Female threaded rod end

For a female threaded rod end, the reference point is located on the rod centreline at the end of the piston rod. See Figure 3.

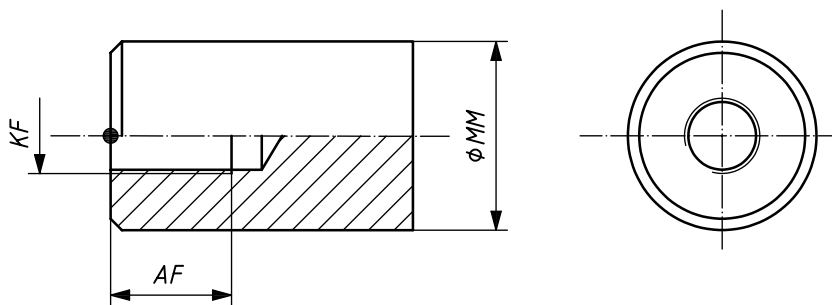

Figure 3 — RTF_x: Female threaded rod end

4.1.5 Male threaded rod end

For a male threaded rod end, the reference point is located on the rod centreline, at the shoulder level. See Figure 4.

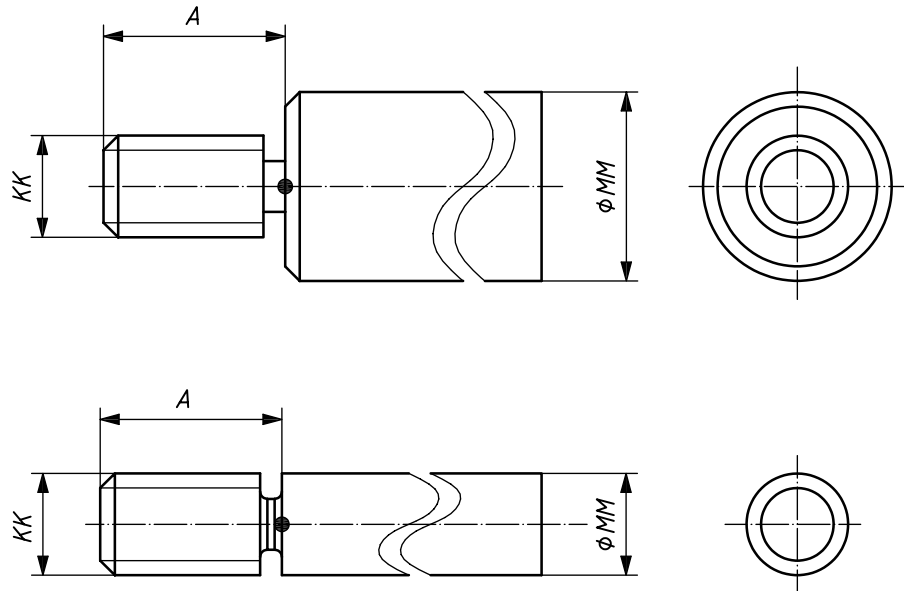
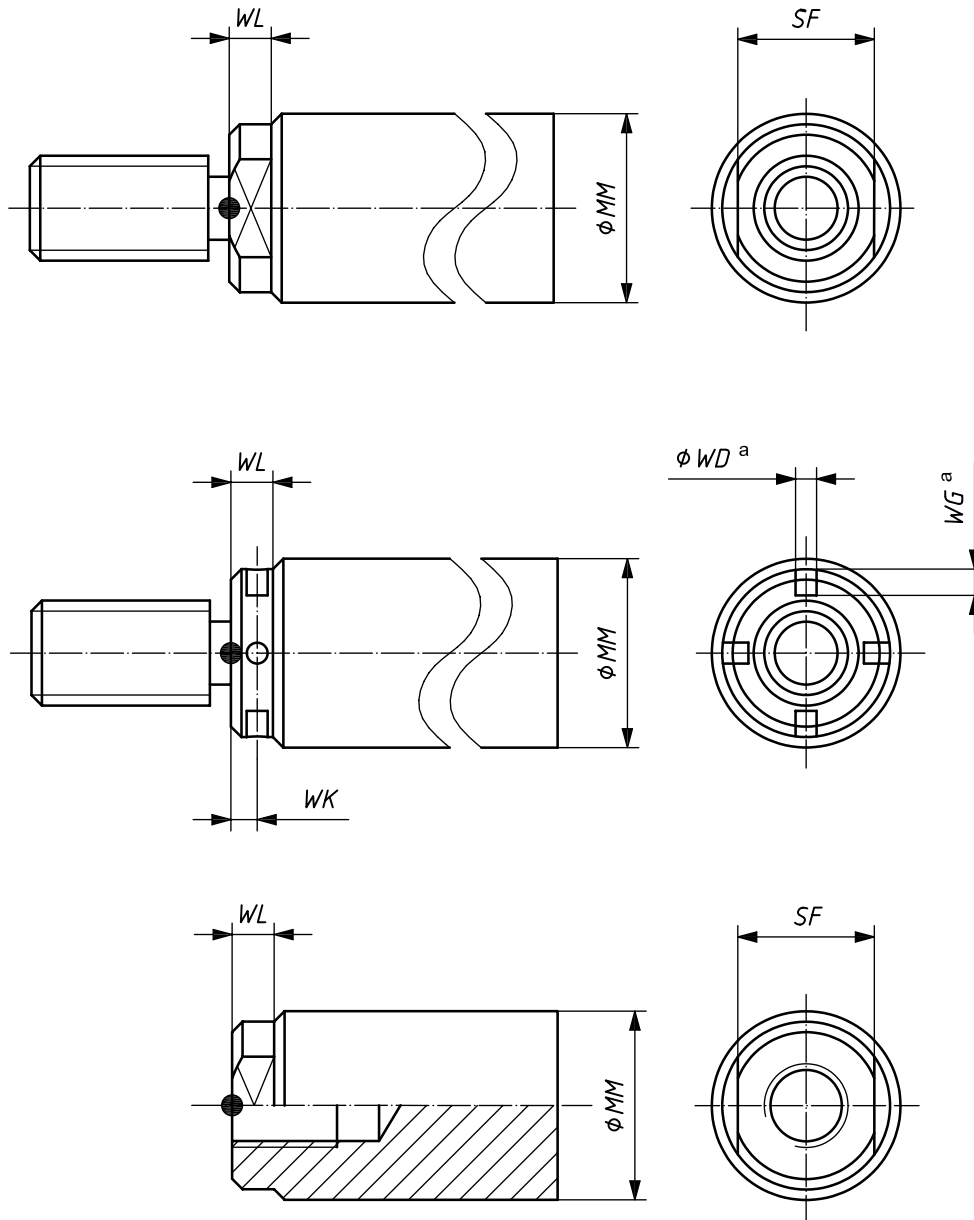

Figure 4 — RTM_x : Male threaded rod end

4.1.6 Wrench flat piston rod end or hook wrench holes

For a wrench flat piston rod end or hook wrench holes, the reference point is located on the wrench flat or hook wrench holes, centreline and the piston rod centreline. See Figure 5.



^a Optional.

Figure 5 — Wrench flat piston rod end or hook wrench holes

4.1.7 Flanged piston rod end — Alternative reference points

For a flanged piston rod end, the reference point is either located on the rod centreline at the end of the piston rod (see Figure 6) or on the rod centreline at the shoulder level (see Figure 7).

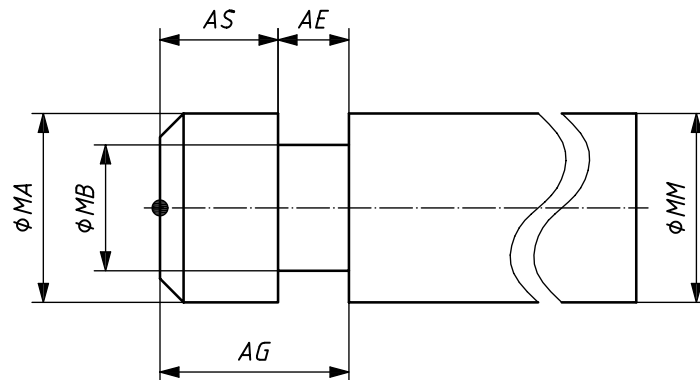

Figure 6 — RFE_x: Flanged piston rod end with TRP at the end of the piston rod

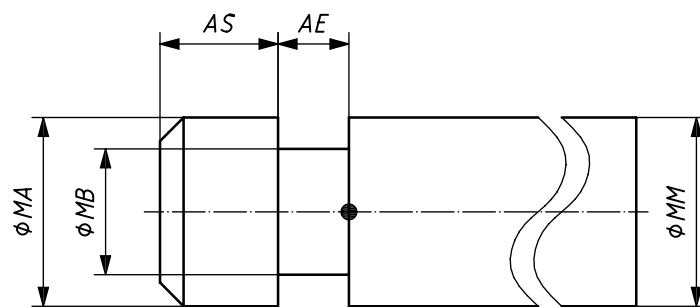

Figure 7 — RFS_x: Flanged piston rod end with TRP at the shoulder level

4.2 Identification code

The identification code for the rod end types is given in Table 1.

Table 1 — Identification code

Identification code	Description
RTM _x	Male threaded rod end
RTF _x	Female threaded rod end
RPE _x	Plain rod end
RPR _x	Pin rod end
RFE _x	Flanged piston rod end with TRP at the end of the piston rod
RFS _x	Flanged piston rod end with TRP at the shoulder level
x	Is designated for the wrench flats or hook wrench: 0 = none 1 = wrench flats 2 = hook wrench

5 Letter code for identifying cylinder mounting, envelope and accessory dimensions

5.1 General

The code for identifying cylinder mounting, envelope and accessory dimensions is composed of one or two letters and, in some cases, the signs: +, ++ or +/.

The meaning of these letters and signs is given in 5.2 to 5.5.

5.2 Letter *Z*

Any group of two letters beginning with *Z* identifies a longitudinal envelope dimension.

5.3 Letter *U*

Any group of two letters beginning with *U* identifies an end view envelope dimension.

5.4 Letters *W, X, Y, Z*

Any group of two letters beginning with *W, X, Y* or *Z* identifies a dimension end from the reference point.

5.5 Signs

The sign + after letters means that the stroke is to be added:

$ZJ+ = ZJ$ plus stroke.

The sign ++ after letters means that twice the stroke is to be added:

$ZM++ = ZM$ plus twice the stroke.

The sign +/ after letters means that half the stroke is to be added:

$XV+/ = XV$ plus half the stroke.

5.6 Dimensioning

The general dimensions are shown in Figure 8.

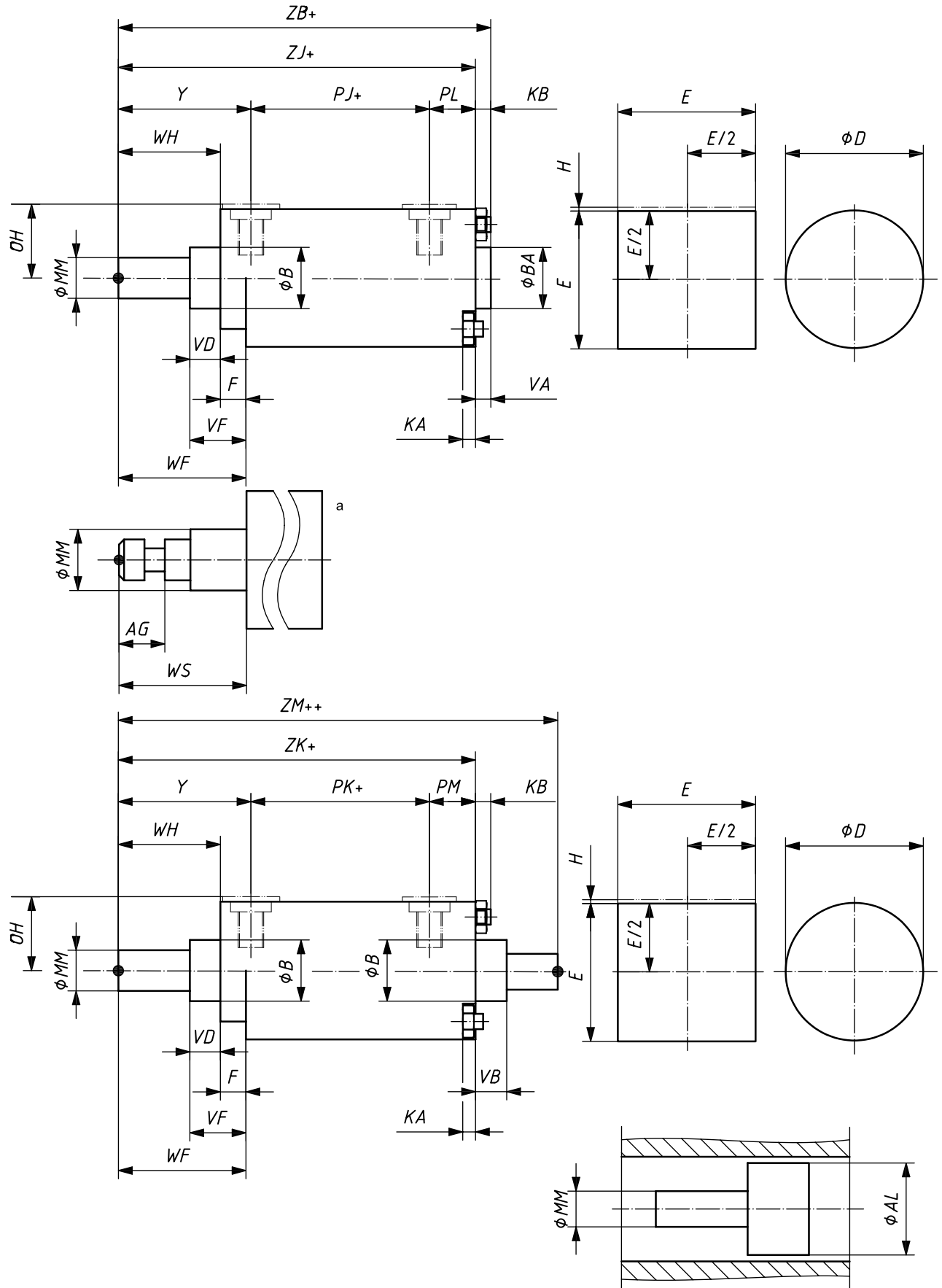

a Refer to Figure 6.

Figure 8 — Arrangement of general cylinder dimensions

6 Identification code for mounting types

6.1 General

The identification code for cylinder mounting types consists of two or three letters and a number.

EXAMPLE

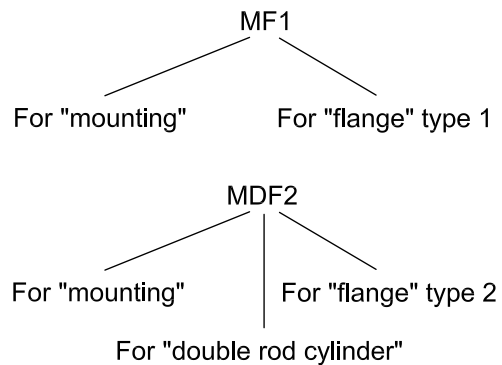

The following letters may be used in place of the letter designating flanges used in the above examples.

Letter	Mounting type
B	body
E	cap or head
F	flange (detachable)
P	pivot
R	threaded nose
S	foot or lugs
T	trunnion
X	studs or tie rods

6.2 Mounting types

The mounting types defined in this International Standard are given with their identifying code in Table 2.

Table 2 — Mounting types

Identification code	Description	Figure
MB 1	Body, through bolt hole	9
MDB 1	Body, through bolt hole — Double rod	10
MB 2	Round, through bolt hole	11
MDB 2	Round, through bolt hole — Double rod	12
ME 5	Head, rectangular	13
MDE 5	Head, rectangular — Double rod	14
ME 6	Cap, rectangular	15
ME 7	Head, round	16
MDE 7	Head, round — Double rod	17
ME 8	Cap, round	18
ME 9	Head, square	19
MDE 9	Head, square — Double rod	20
ME 10	Cap, square	21
ME 11	Head, square	22
MDE 11	Head, square — Double rod	23
ME 12	Cap, square	24
MF 1	Head, rectangular flange	25
MDF 1	Head, rectangular flange — Double rod	26
MF 2	Cap, rectangular flange	27
MF 3	Head, circular flange	28
MDF 3	Head, circular flange — Double rod	29
MF 4	Cap, circular flange	30
MF 5	Head, square flange	31
MDF 5	Head, square flange — Double rod	32
MF 6	Cap, square flange	33
MF 7	Head, circular flange centred on the rear side	34
MDF 7	Head, circular flange centred on the rear side — Double rod	35
MF 8	Head, rectangular flange with two holes	36
MP 1	Cap, fixed clevis	37
MP 2	Cap, detachable clevis	38
MP 3	Cap, fixed plain eye	39
MP 4	Cap, detachable plain eye	40
MP 5	Cap, fixed eye with spherical bearing	41
MP 6	Cap, detachable eye with spherical bearing	42
MP 7	Head, detachable clevis	43
MR 3	Head, threaded	44
MDR 3	Head, threaded — Double rod	45
MR 4	Cap, threaded	46

Table 2 (continued)

Identification code	Description	Figure
MS 1	End angles	47
MDS 1	End angles — Double rod	48
MS 2	Side lugs	49
MDS 2	Side lugs — Double rod	50
MS 3	Head angle	51
MT 1	Head, integral trunnion (male)	52
MDT 1	Head, integral trunnion (male) — Double rod	53
MT 2	Cap, integral trunnion (male)	54
MT 4	Intermediate trunnion (male) fixed or mobile	55
MDT 4	Intermediate trunnion (male) fixed or mobile — Double rod	56
MT 5	Head, detachable trunnion (male)	57
MT 6	Cap, detachable trunnion (male)	58
MX 1	Both ends studs or tie rods extended	59
MDX 1	Both ends studs or tie rods extended — Double rod	60
MX 2	Cap studs or tie rods extended	61
MDX 2	Cap studs or tie rods extended — Double rod	62
MX 3	Head studs or tie rods extended	63
MX 4	Both ends 2 studs or tie rods extended	64
MDX 4	Both ends 2 studs or tie rods extended — Double rod	65
MX 5	Head, tapped	66
MDX 5	Head, tapped — Double rod	67
MX 6	Cap, tapped	68
MX 7	Head, tapped, and cap studs or tie rods extended	69
MDX 7	Head, tapped, and cap studs or tie rods extended — Double rod	70
MX 8	Head and cap, tapped	71
MDX 8	Head and cap, tapped — Double rod	72

6.3 Letter codes of mounting and envelope dimensions according to cylinder mounting type

The letter code for mounting and envelope dimensions according to cylinder mounting type is shown in Figure 9 to Figure 72, and the designation is given in Table 4.

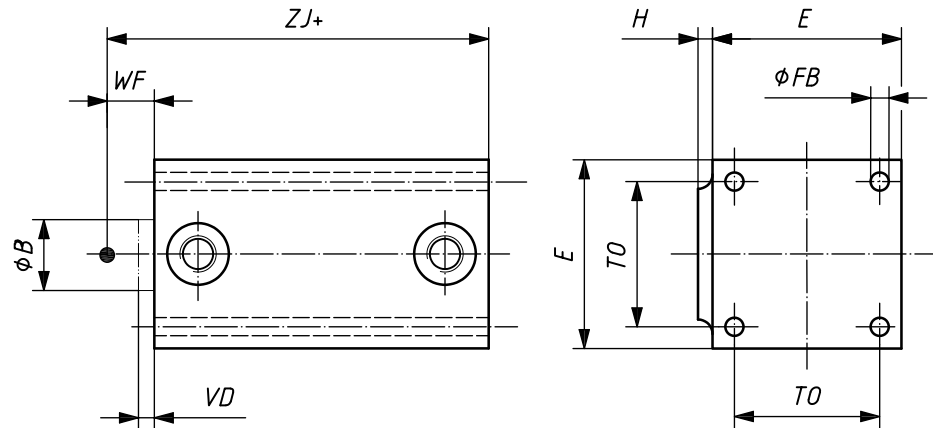

Figure 9 — MB 1: Body, through bolt hole

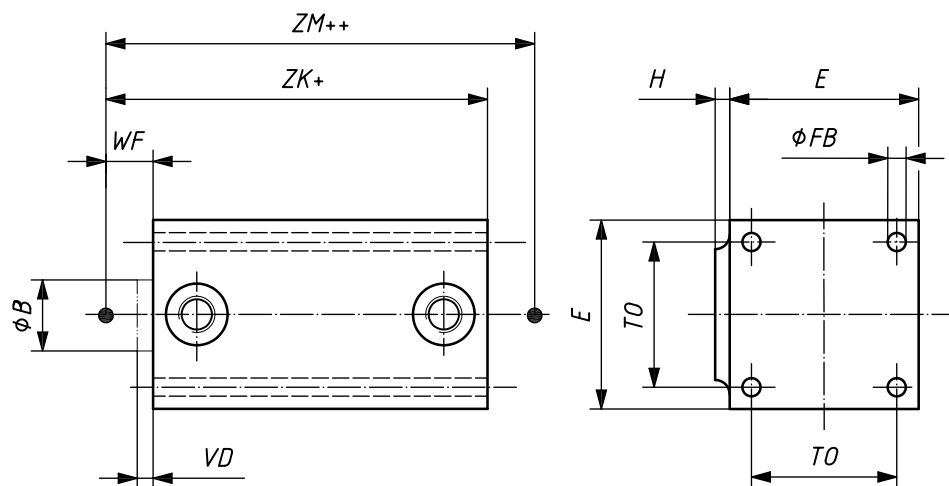

Figure 10 — MDB 1: Body, through bolt hole — Double rod

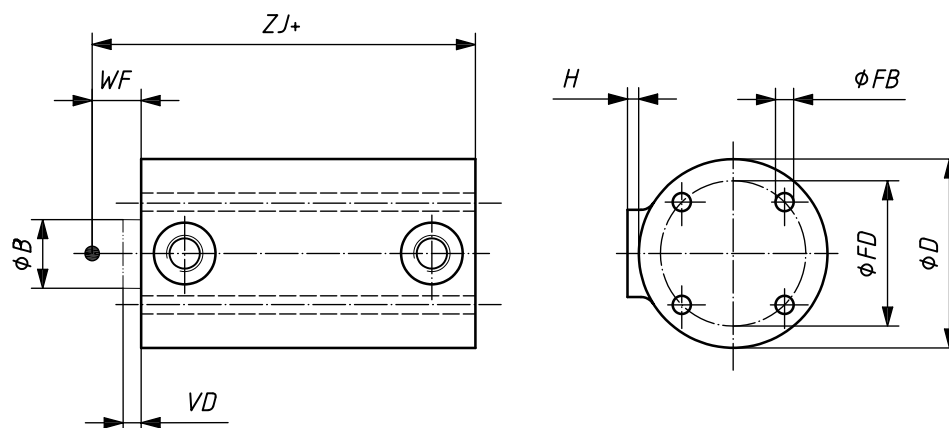

Figure 11 — MB 2: Round, through bolt hole

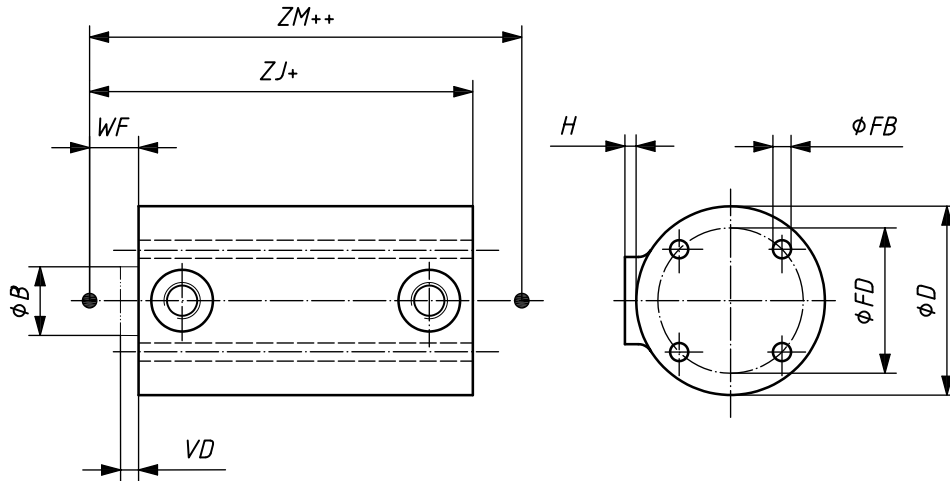

Figure 12 — MDB 2: Round, through bolt hole — Double rod

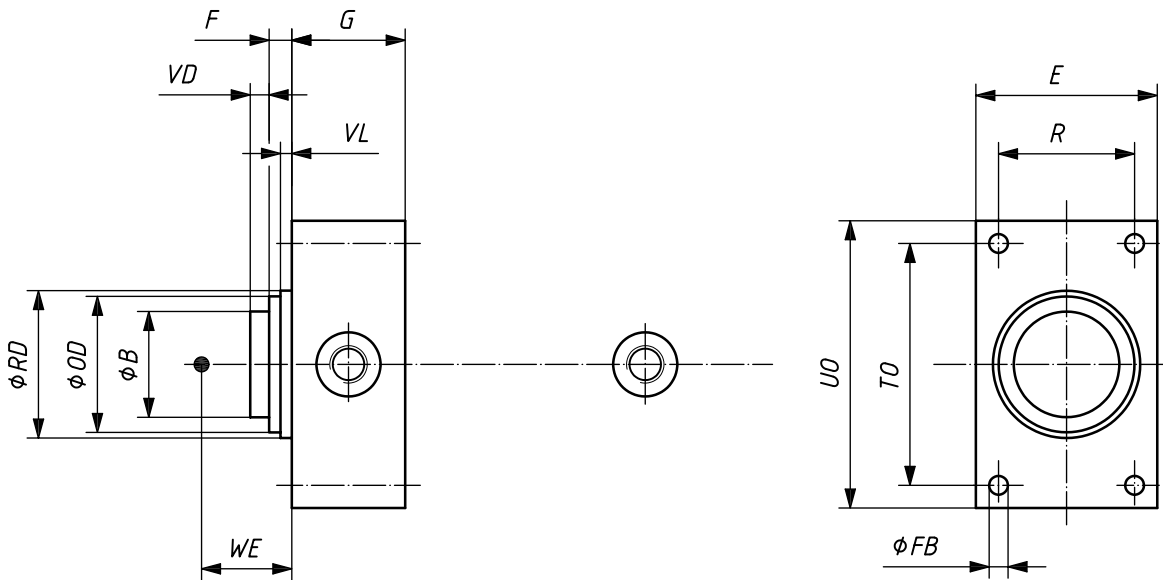

Figure 13 — ME 5: Head, rectangular

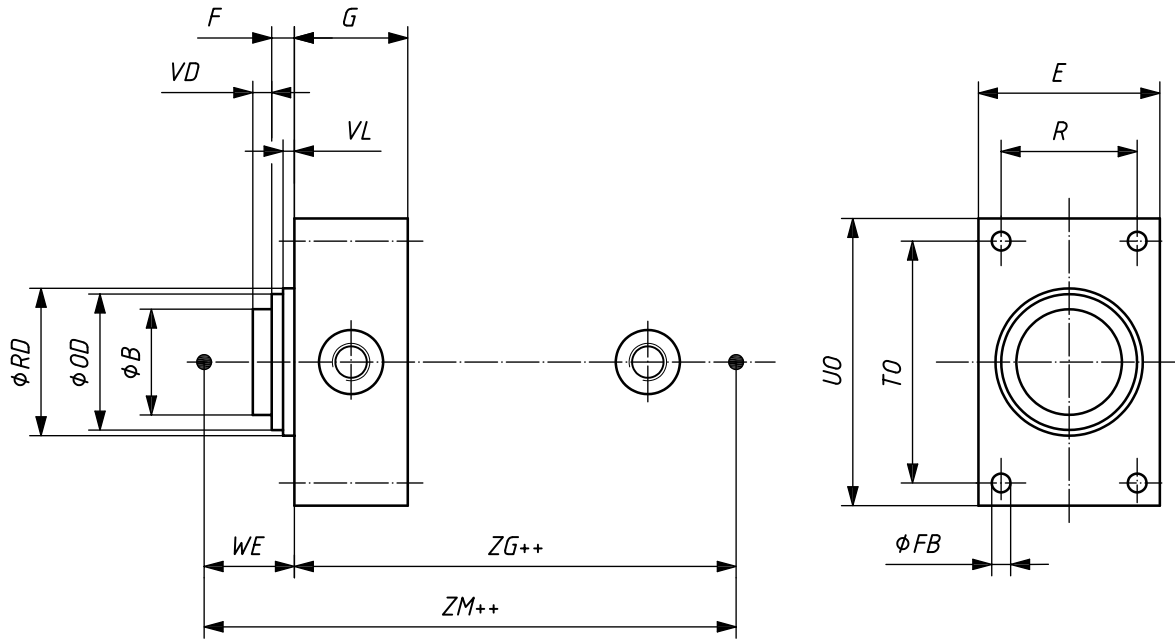

Figure 14 — MDE 5: Head, rectangular — Double rod

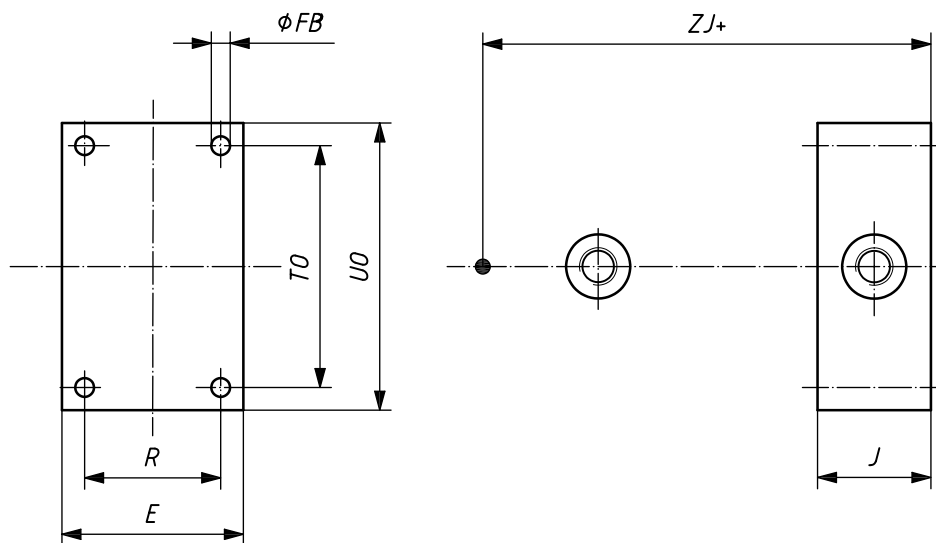

Figure 15 — ME 6: Cap, rectangular

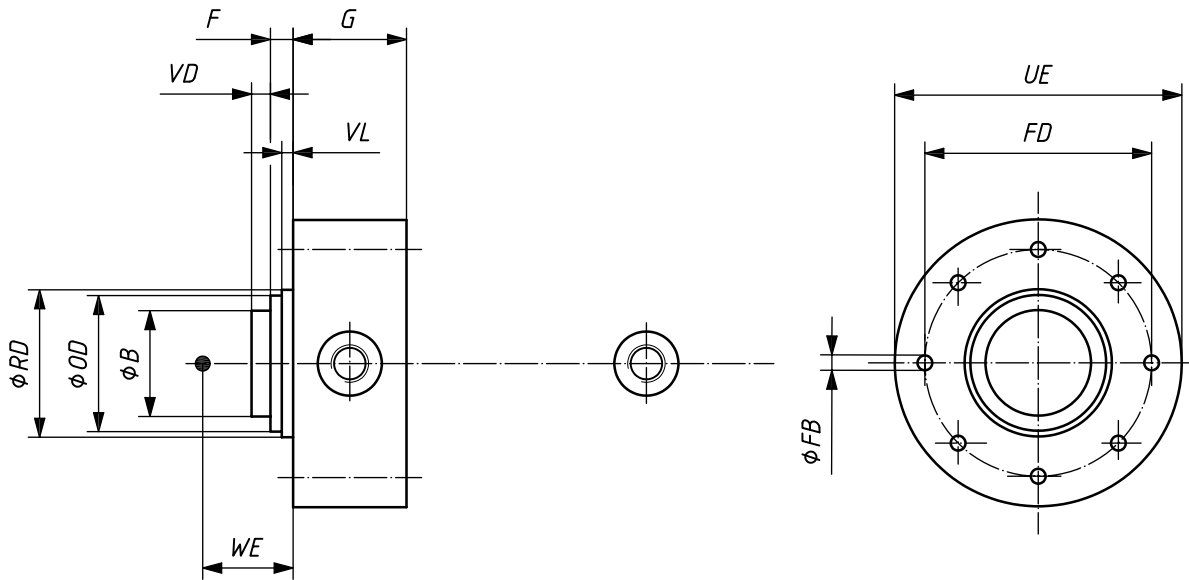

Figure 16 — ME 7: Head, round

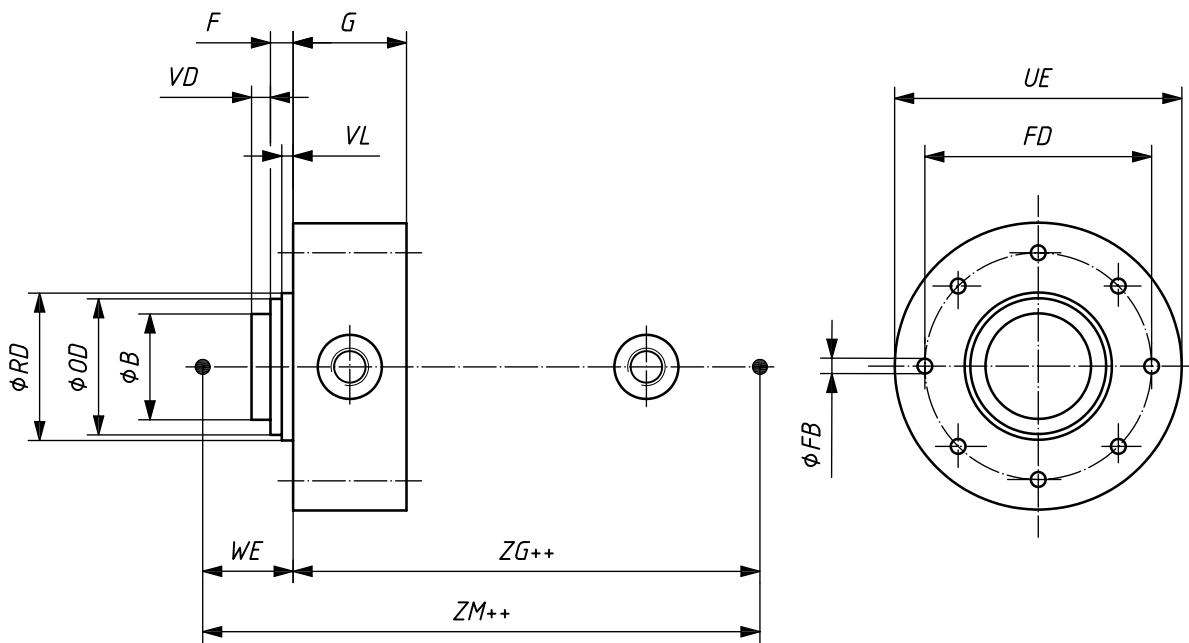

Figure 17 — MDE 7: Head, round — Double rod

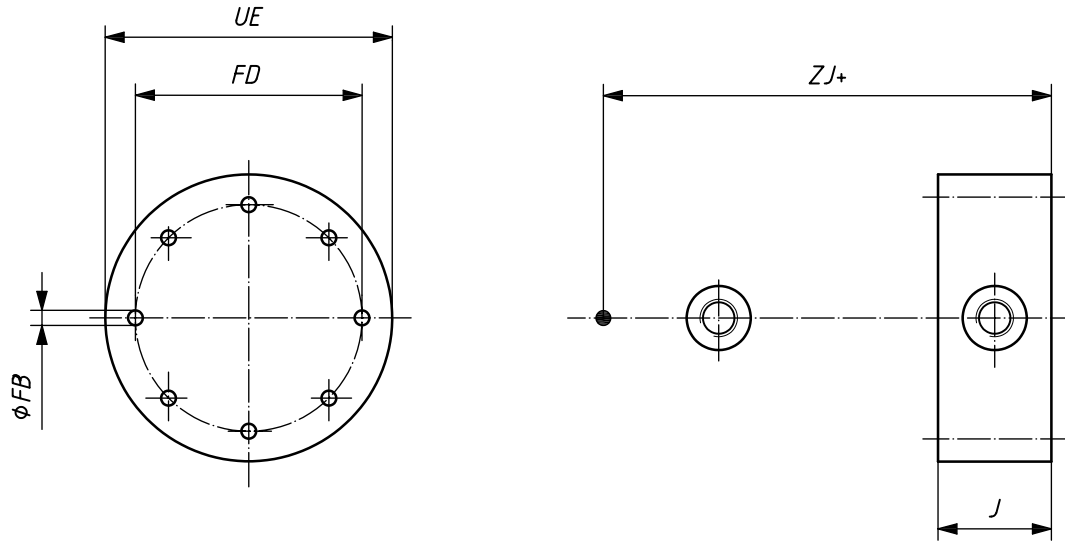

Figure 18 — ME 8: Cap, round

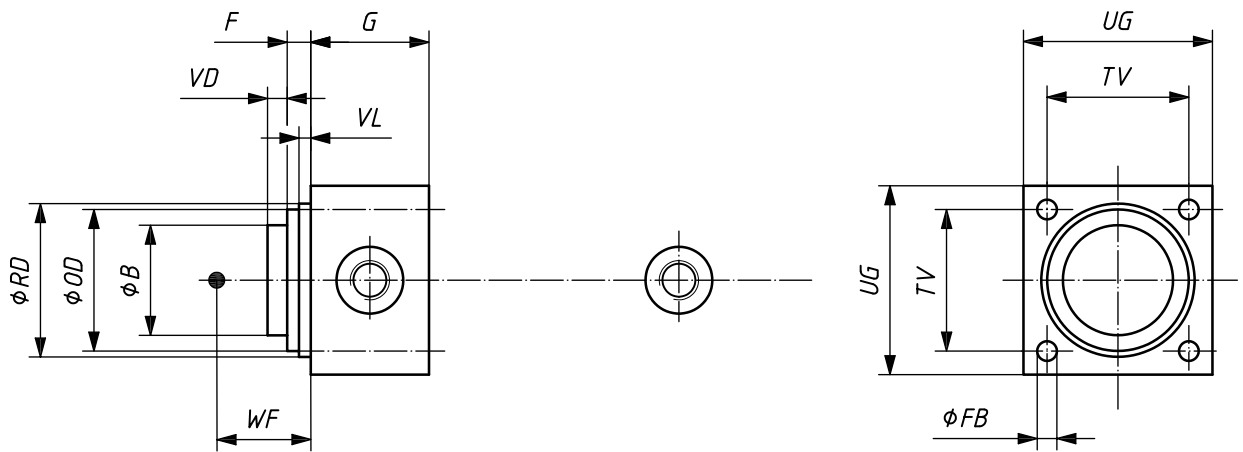

Figure 19 — ME 9: Head, square

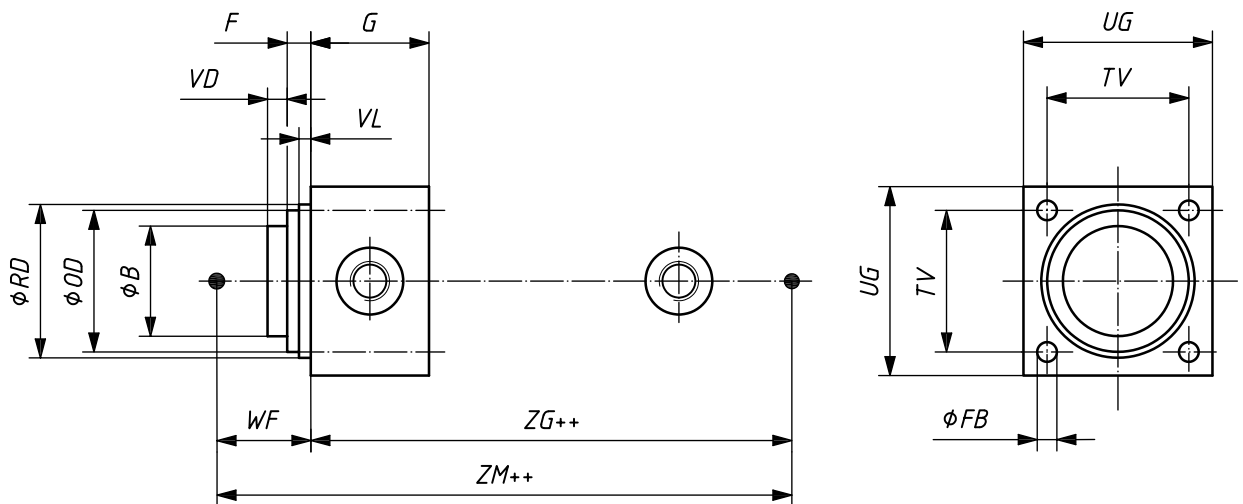

Figure 20 — MDE 9: Head, square — Double rod

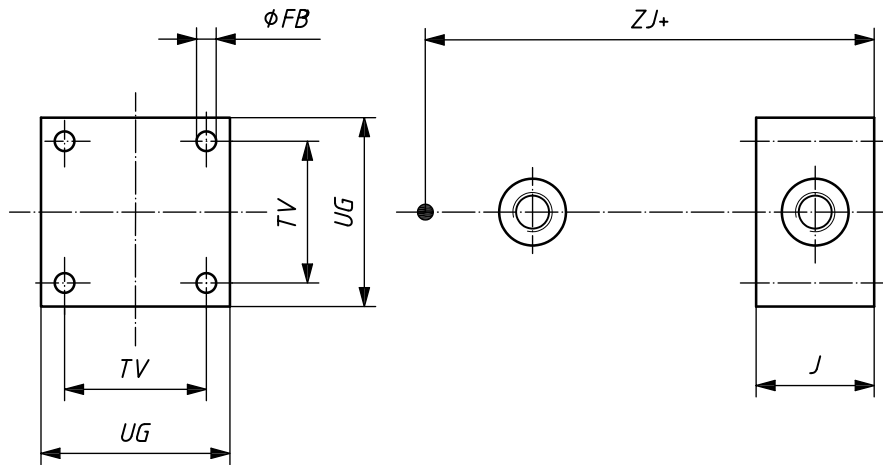

Figure 21 — ME 10: Cap, square

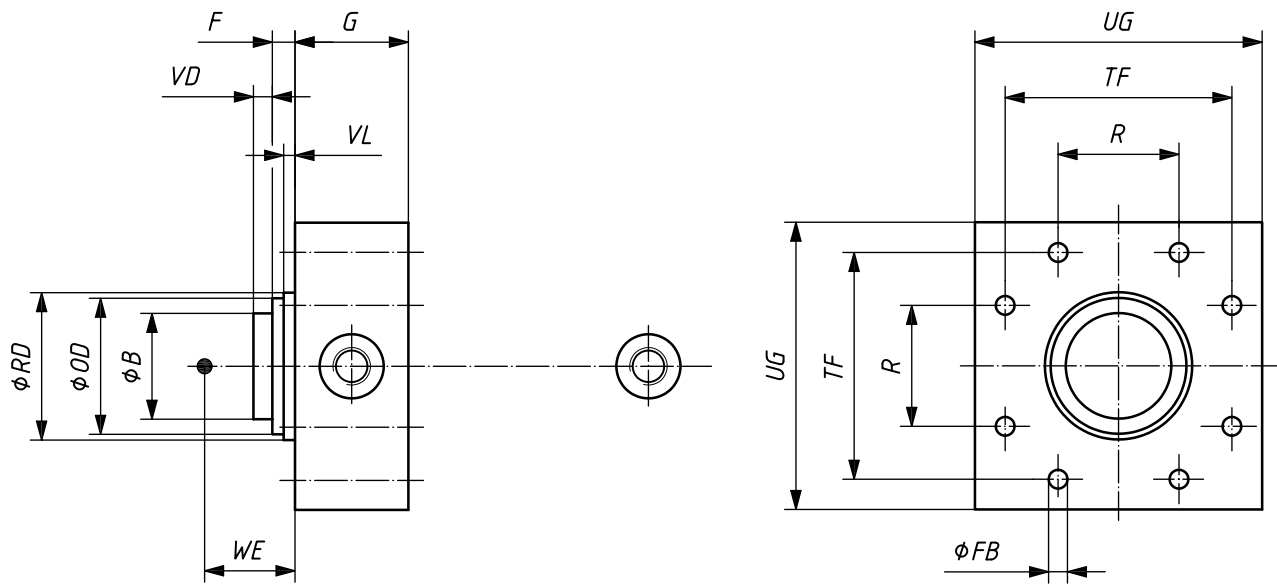

Figure 22 — ME 11: Head, square

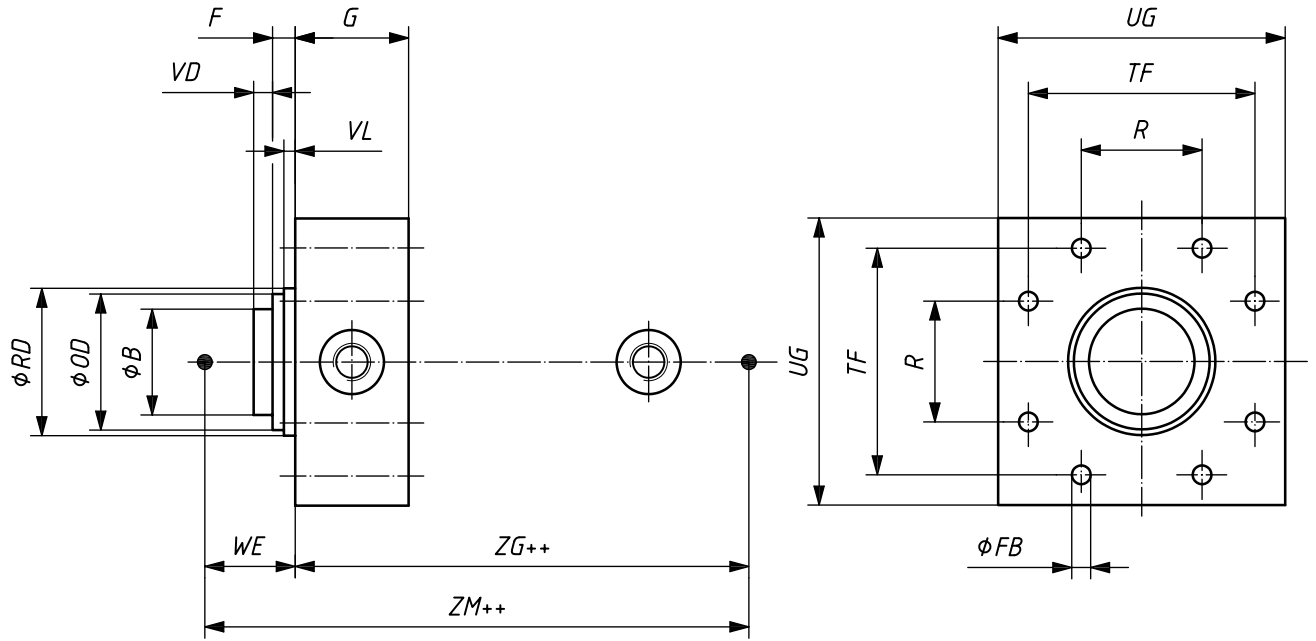

Figure 23 — MDE 11: Head, square — Double rod

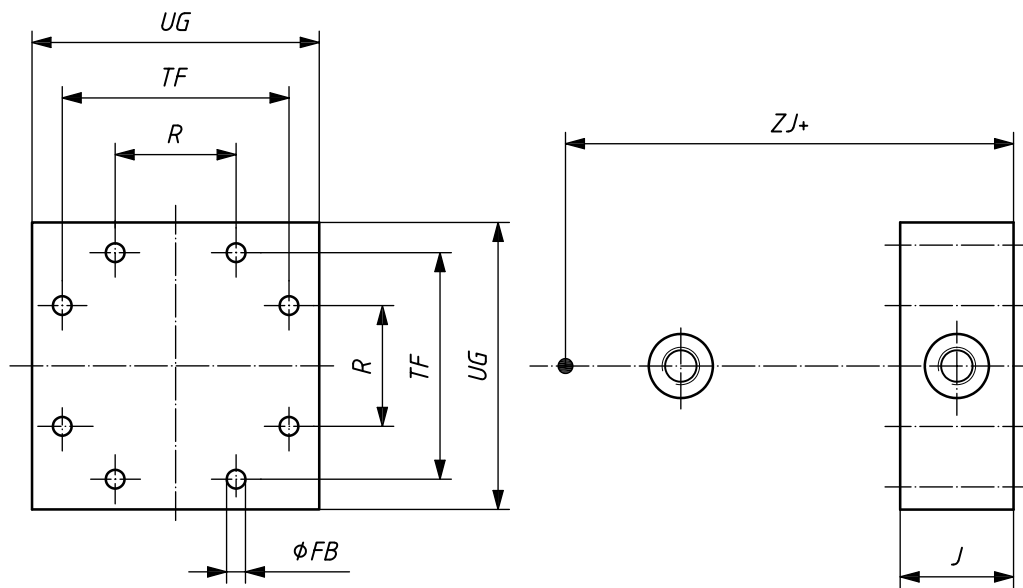

Figure 24 — ME 12: Cap, square

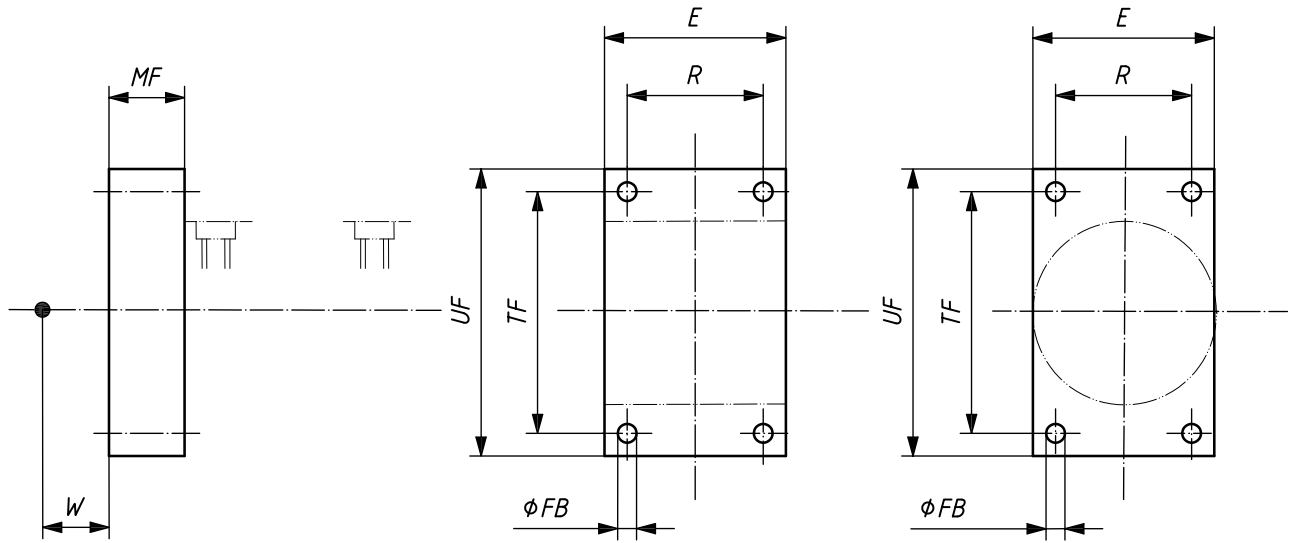

Figure 25 — MF 1: Head, rectangular flange

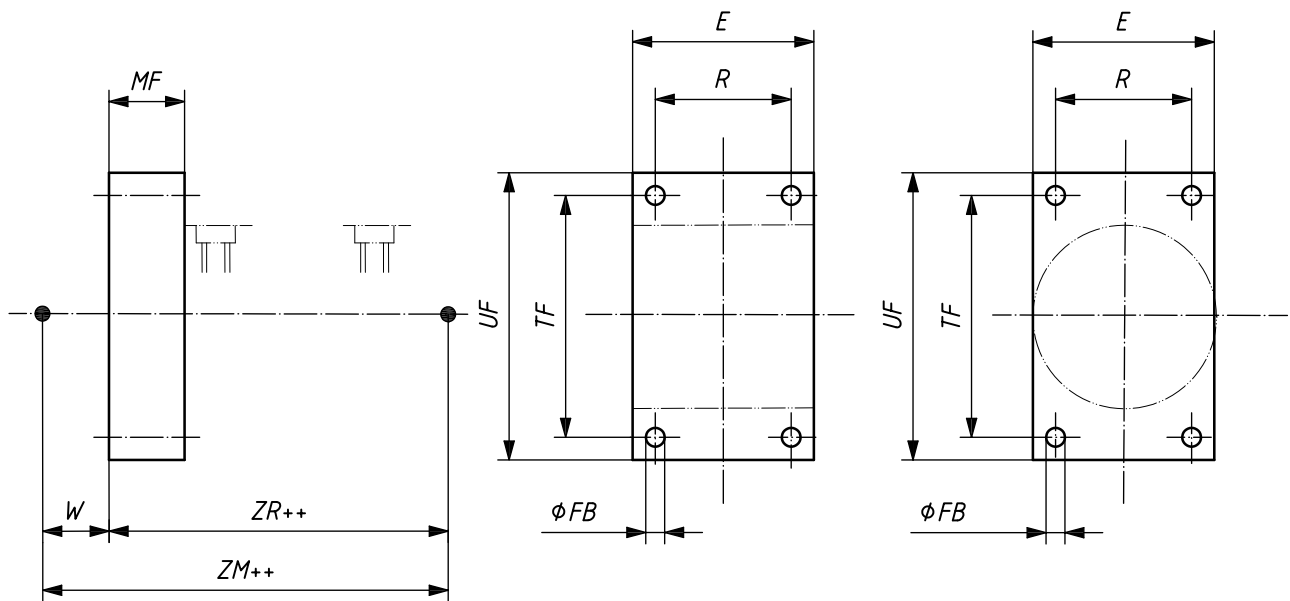

Figure 26 — MDF 1: Head, rectangular flange — Double rod

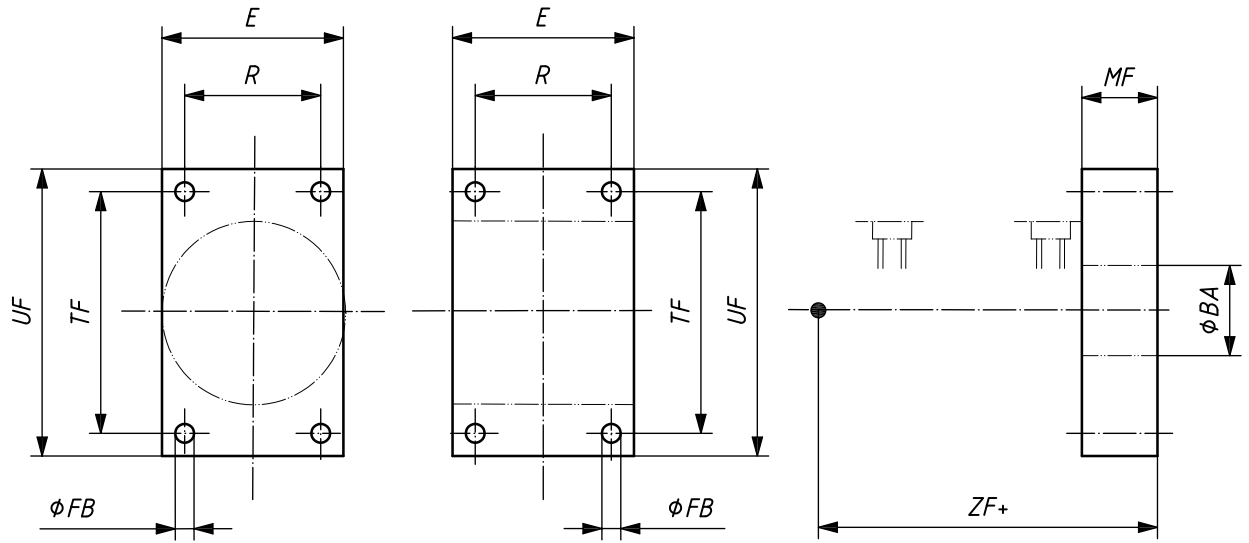

Figure 27 — MF 2: Cap, rectangular flange

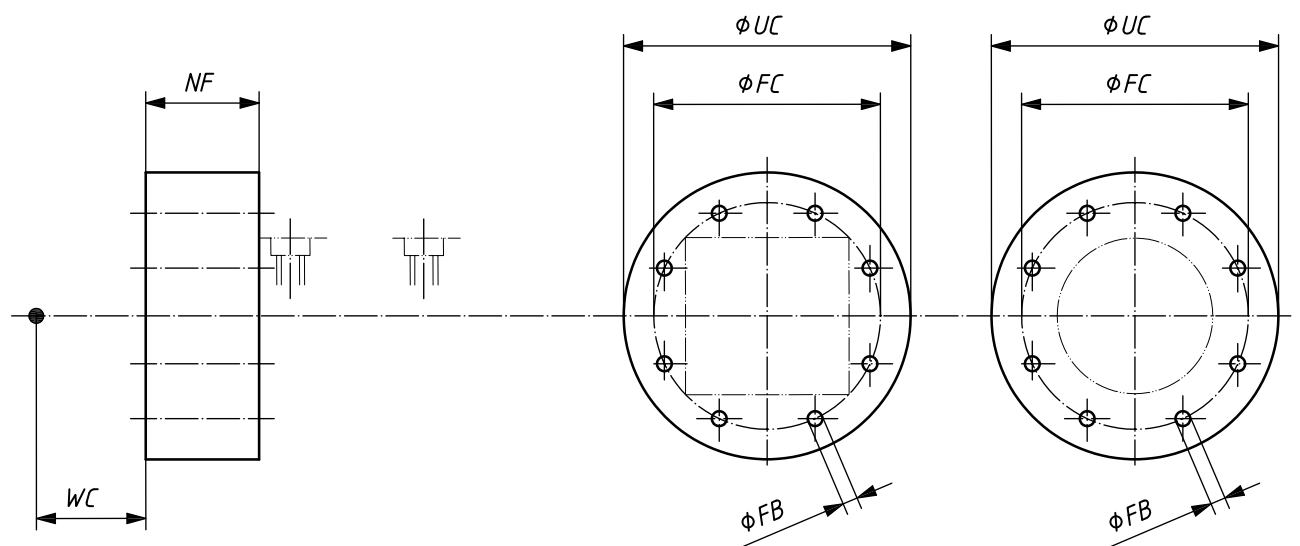

Figure 28 — MF 3: Head, circular flange

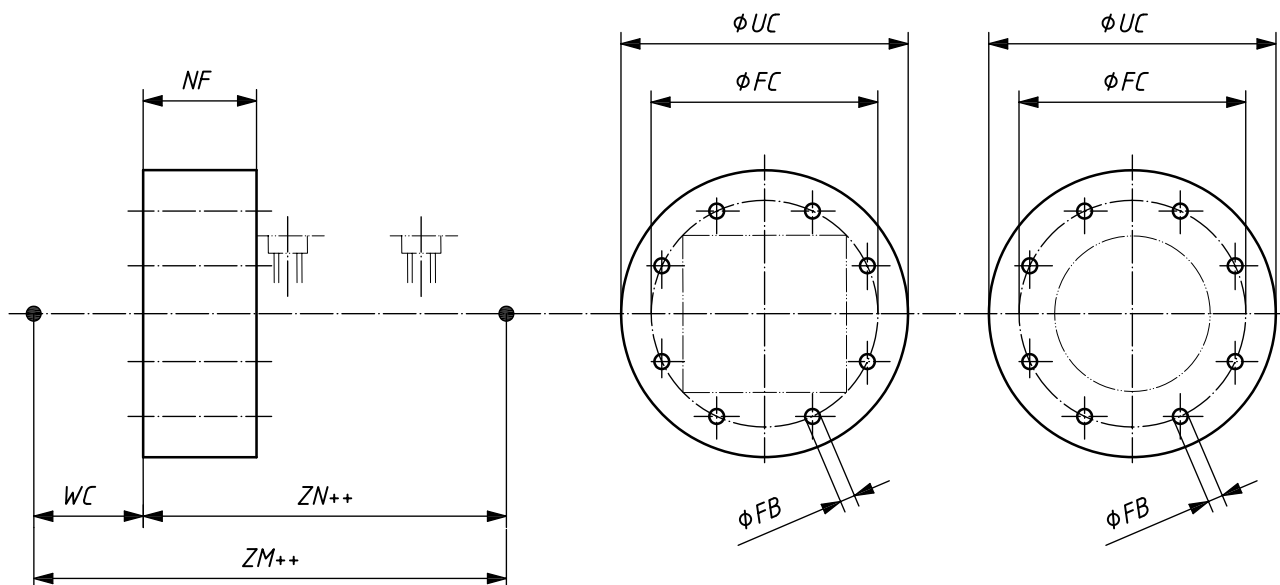

Figure 29 — MDF 3: Head, circular flange — Double rod

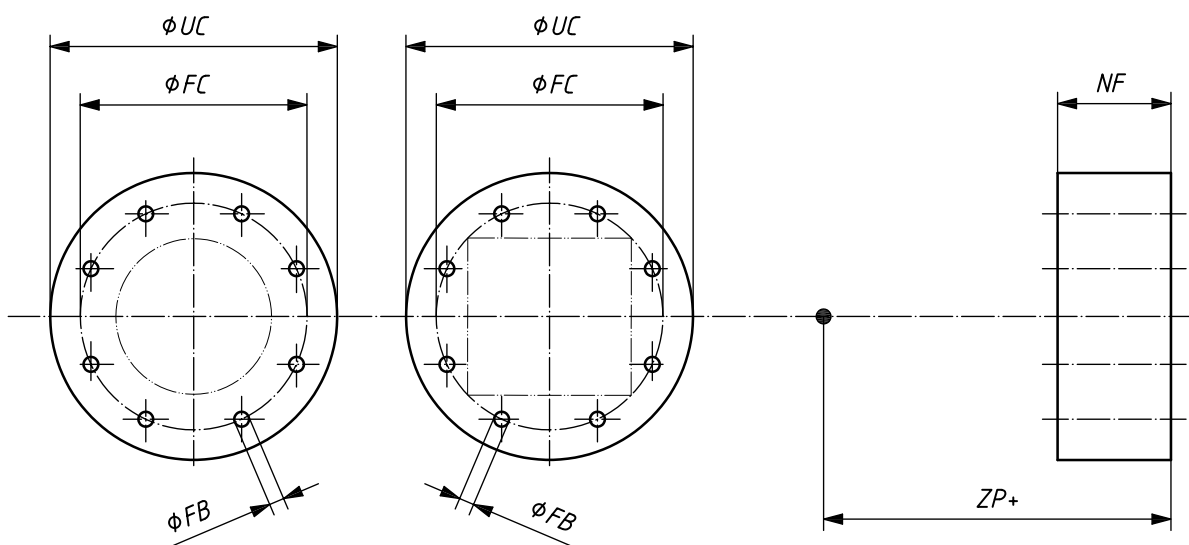

Figure 30 — MF 4: Cap, circular flange

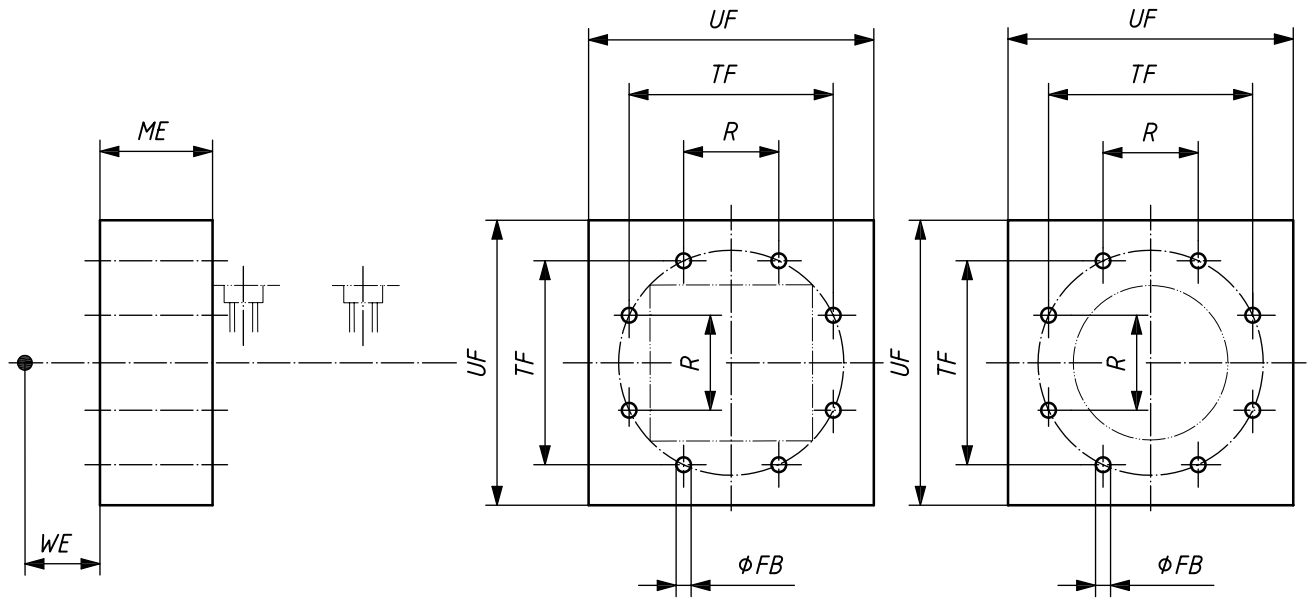

Figure 31 — MF 5: Head, square flange

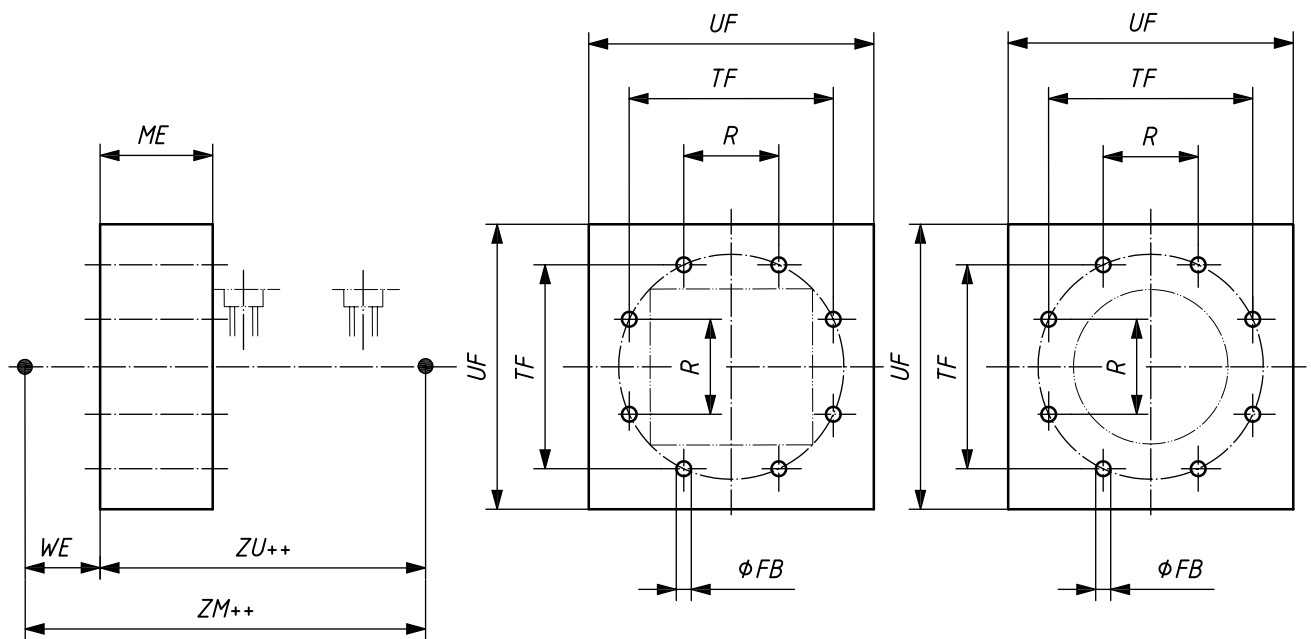

Figure 32 — MDF 5: Head, square flange — Double rod

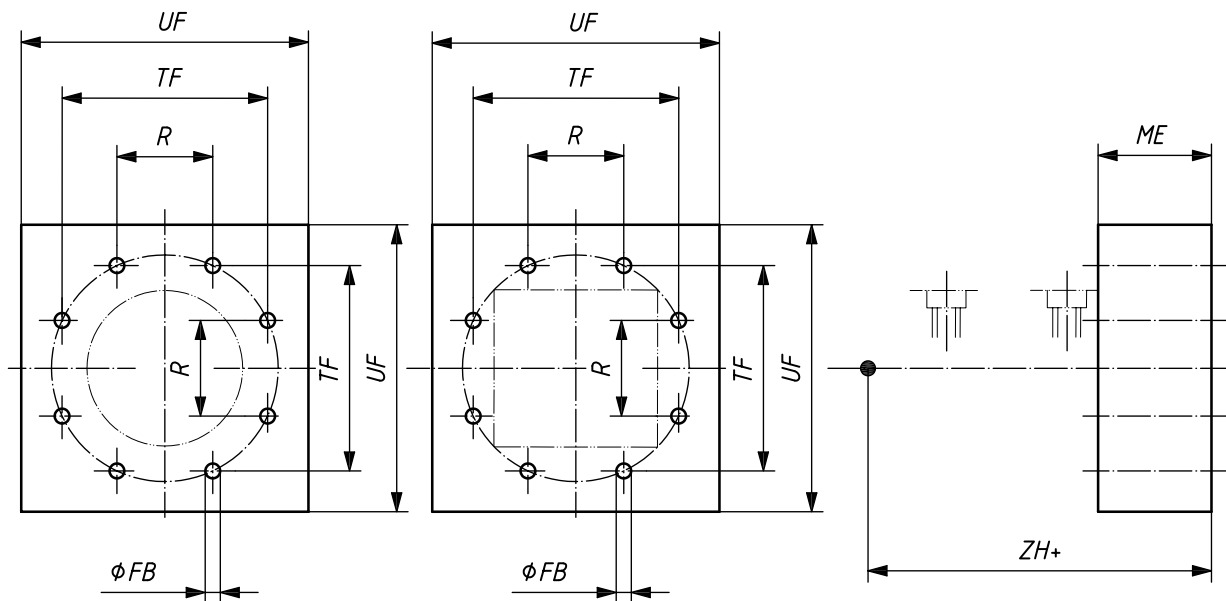

Figure 33 — MF 6: Cap, square flange

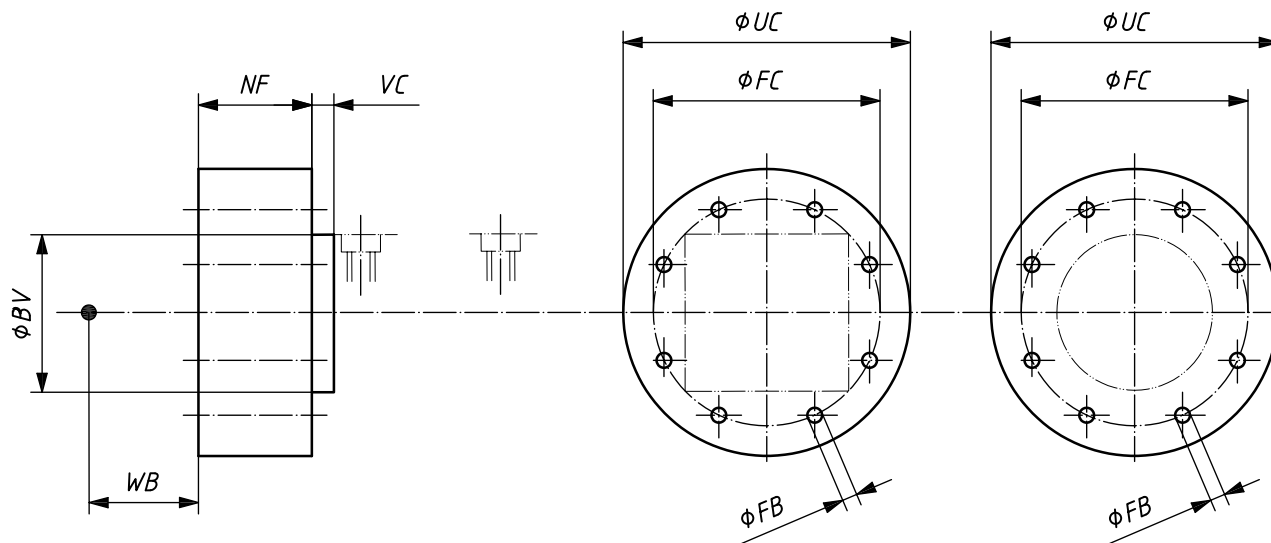

Figure 34 — MF 7: Head, circular flange centred on the rear side

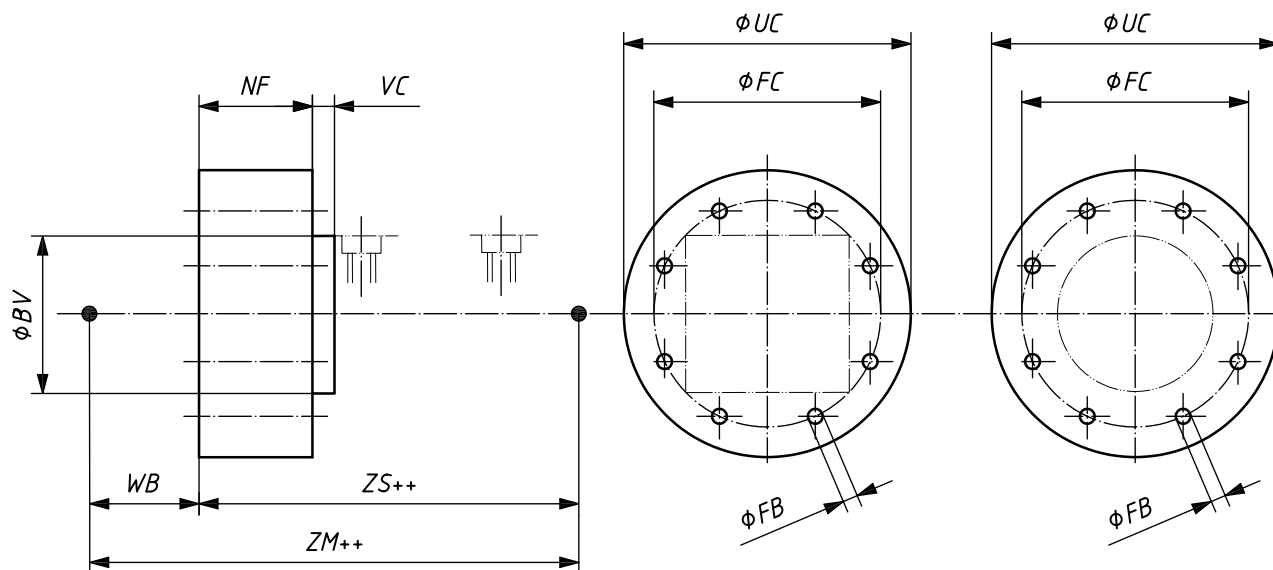

Figure 35 — MDF 7: Head, circular flange centred on the rear side — Double rod

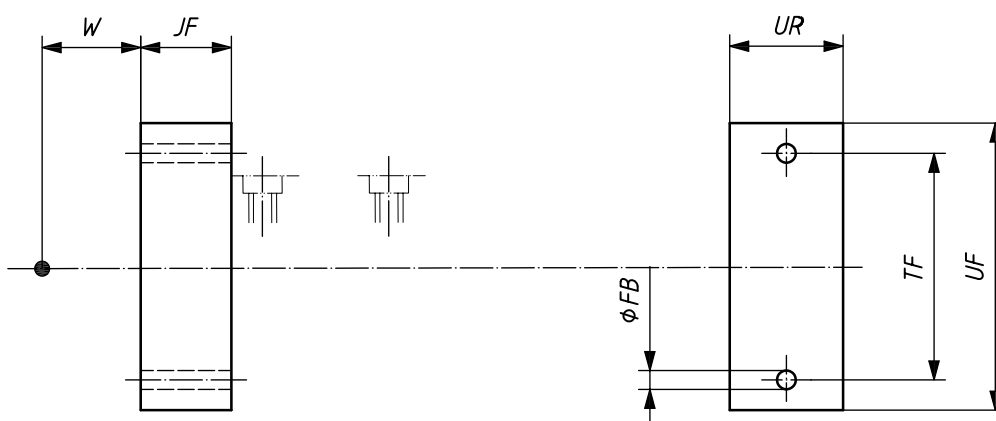

Figure 36 — MF 8: Head, rectangular flange with two holes

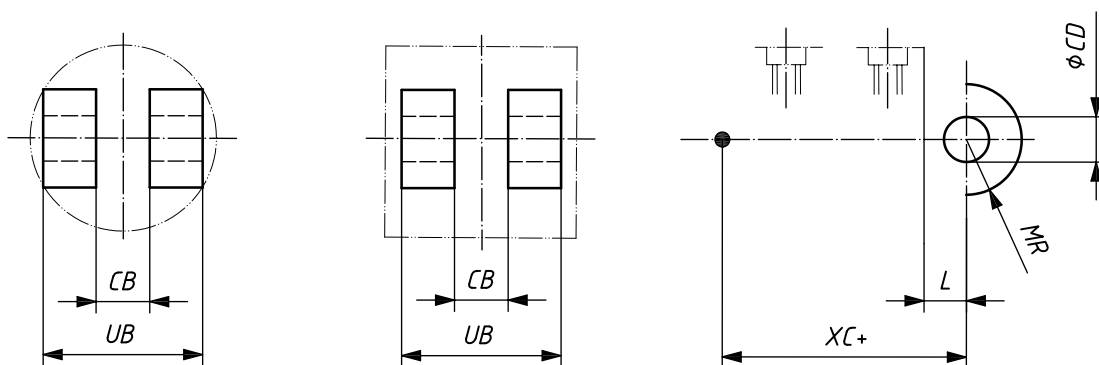

Figure 37 — MP 1: Cap, fixed clevis

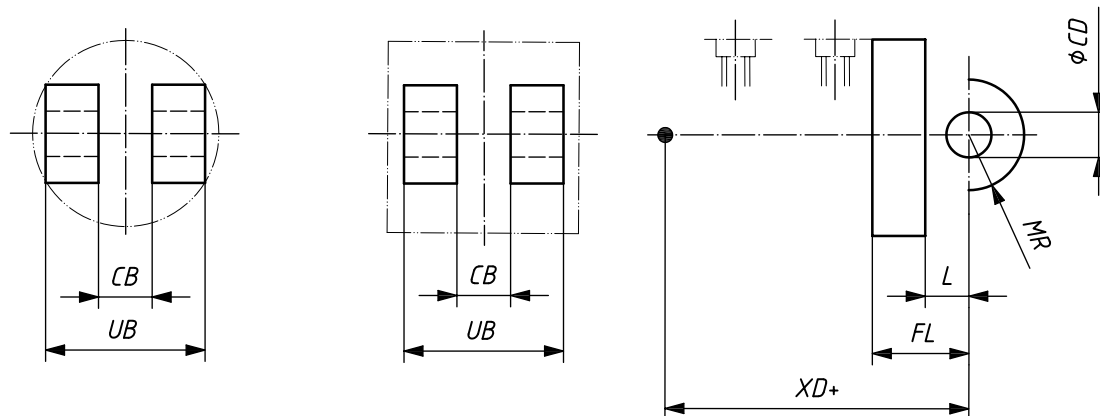

Figure 38 — MP 2: Cap, detachable clevis

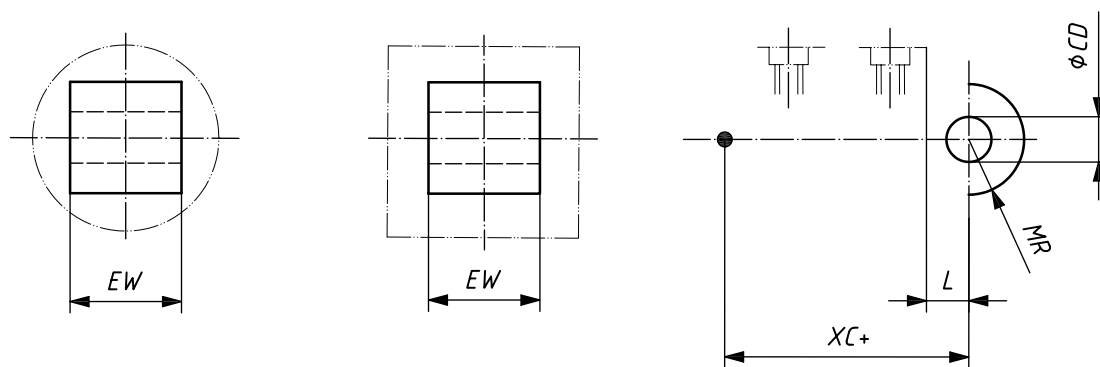

Figure 39 — MP 3: Cap, fixed plain eye

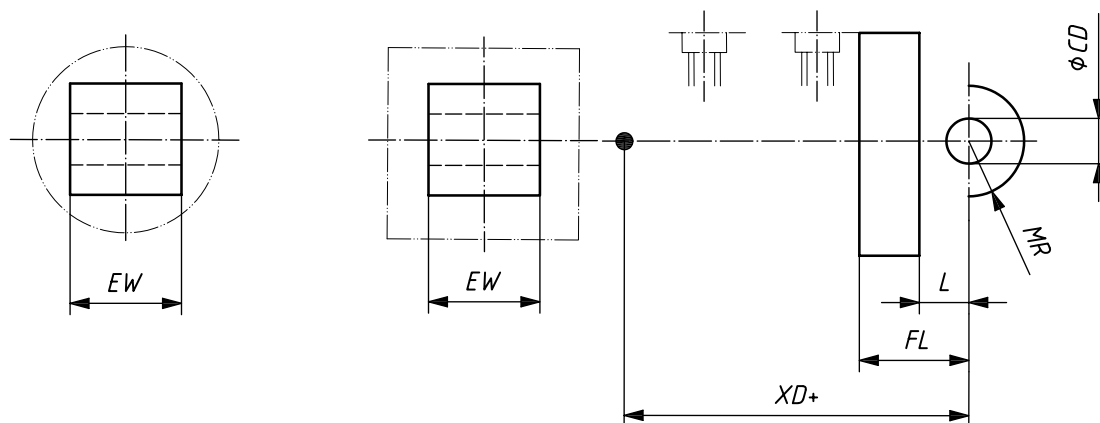

Figure 40 — MP 4: Cap, detachable plain eye

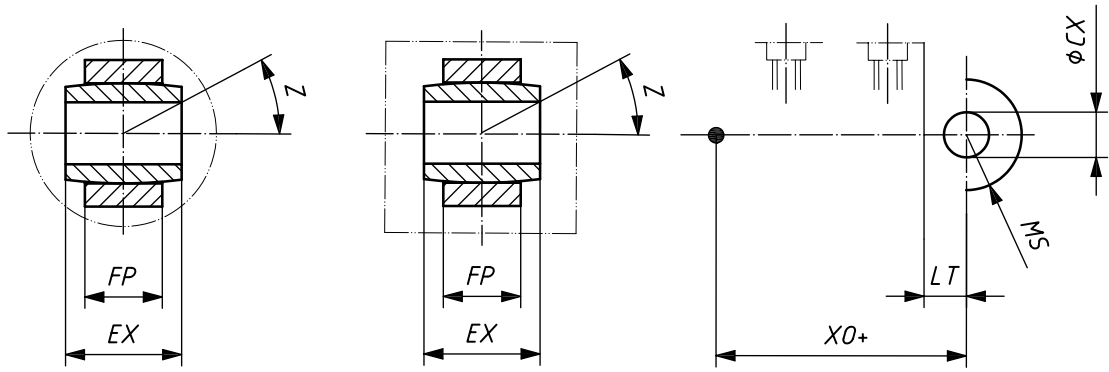

Figure 41 — MP 5: Cap, fixed eye with spherical bearing

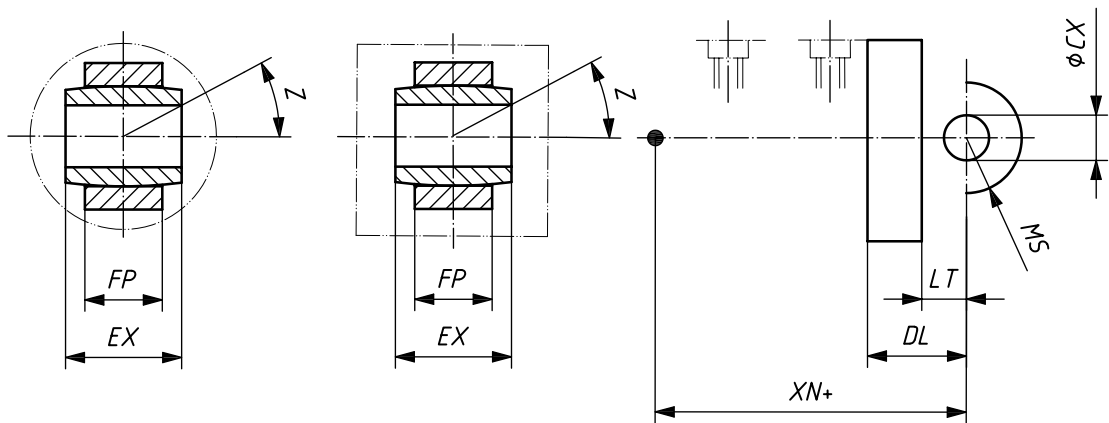

Figure 42 — MP 6: Cap, detachable eye with spherical bearing

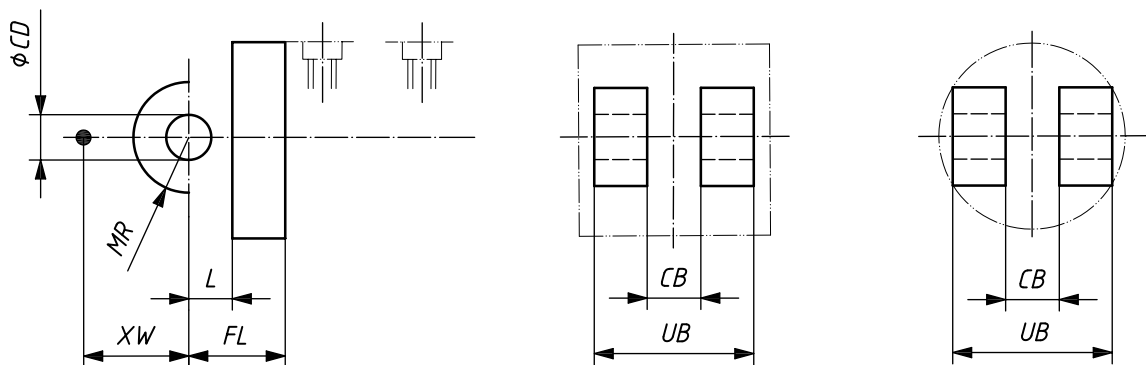

Figure 43 — MP 7: Head, detachable clevis

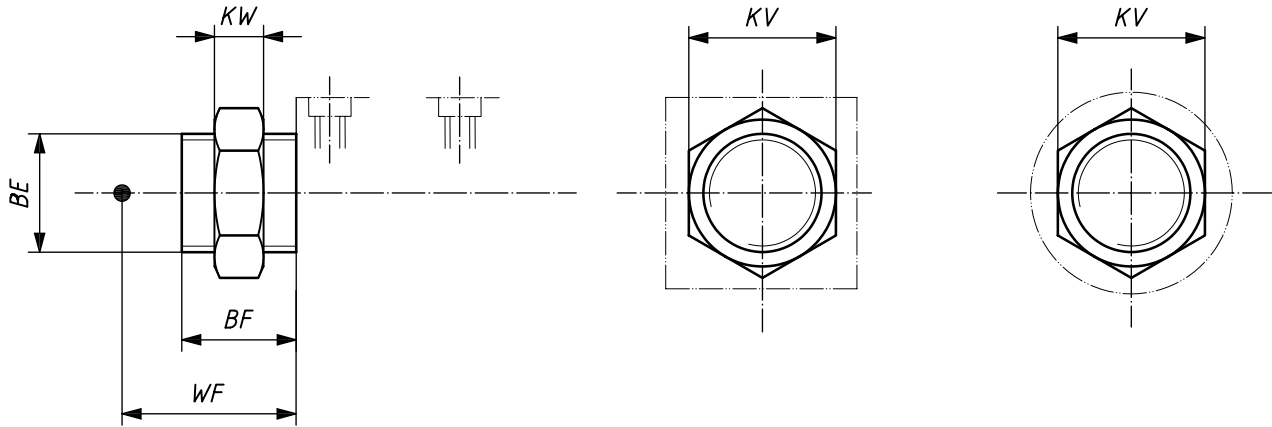

Figure 44 — MR 3: Head, threaded

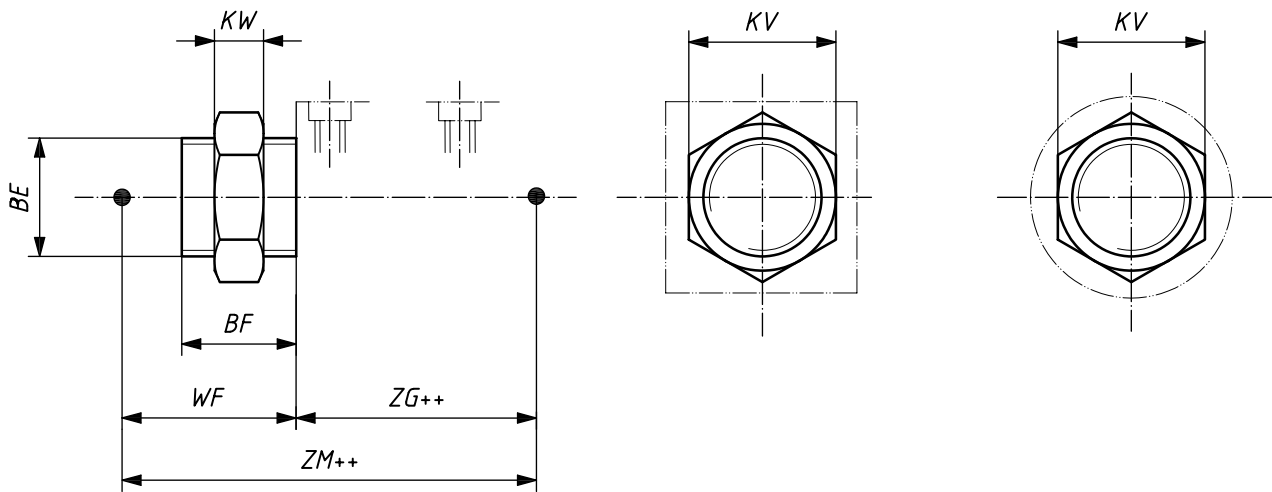

Figure 45 — MDR 3: Head, threaded — Double rod

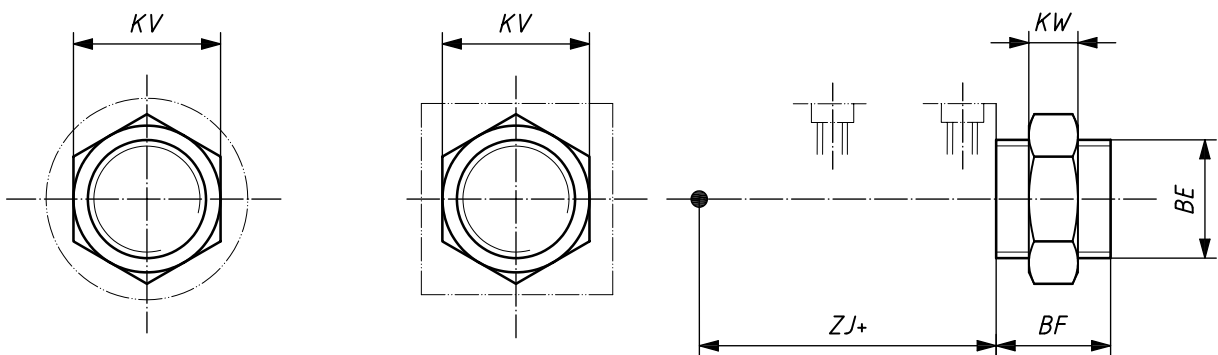

Figure 46 — MR 4: Cap, threaded

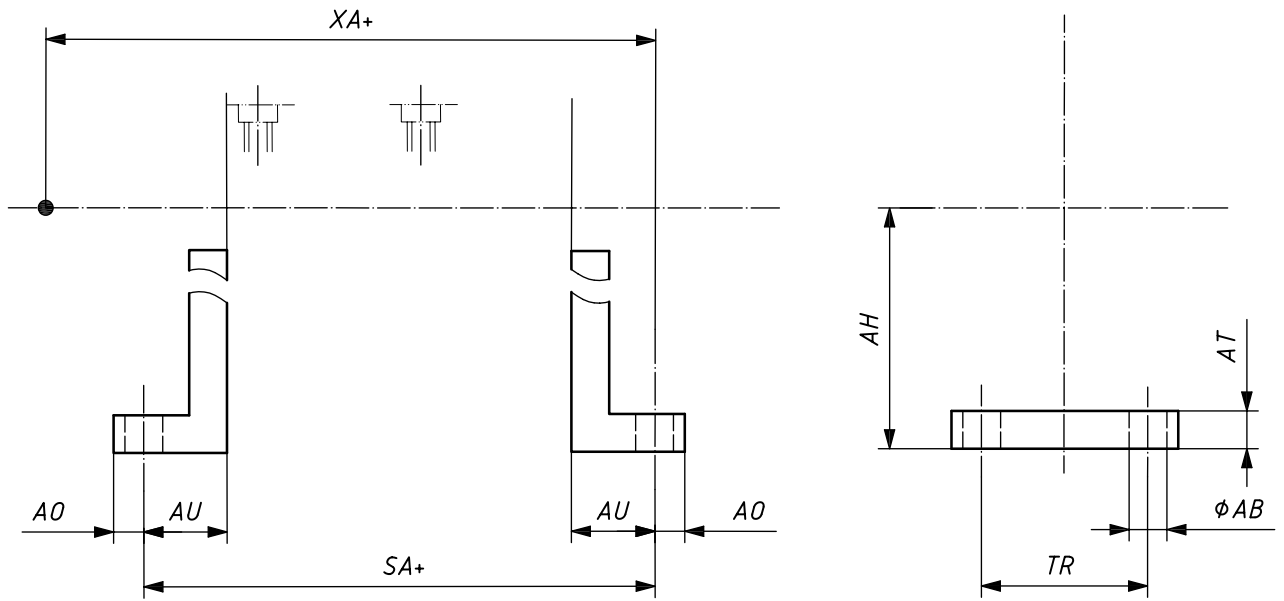

Figure 47 — MS 1: End angles

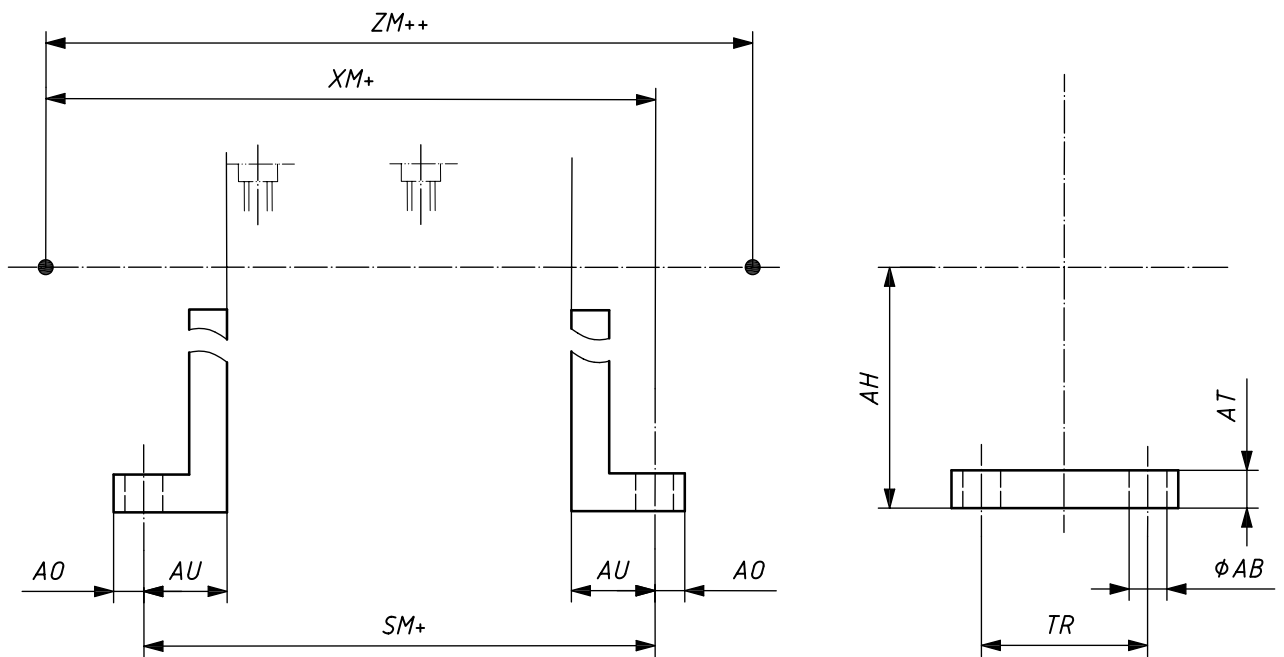

Figure 48 — MDS 1: End angles — Double rod

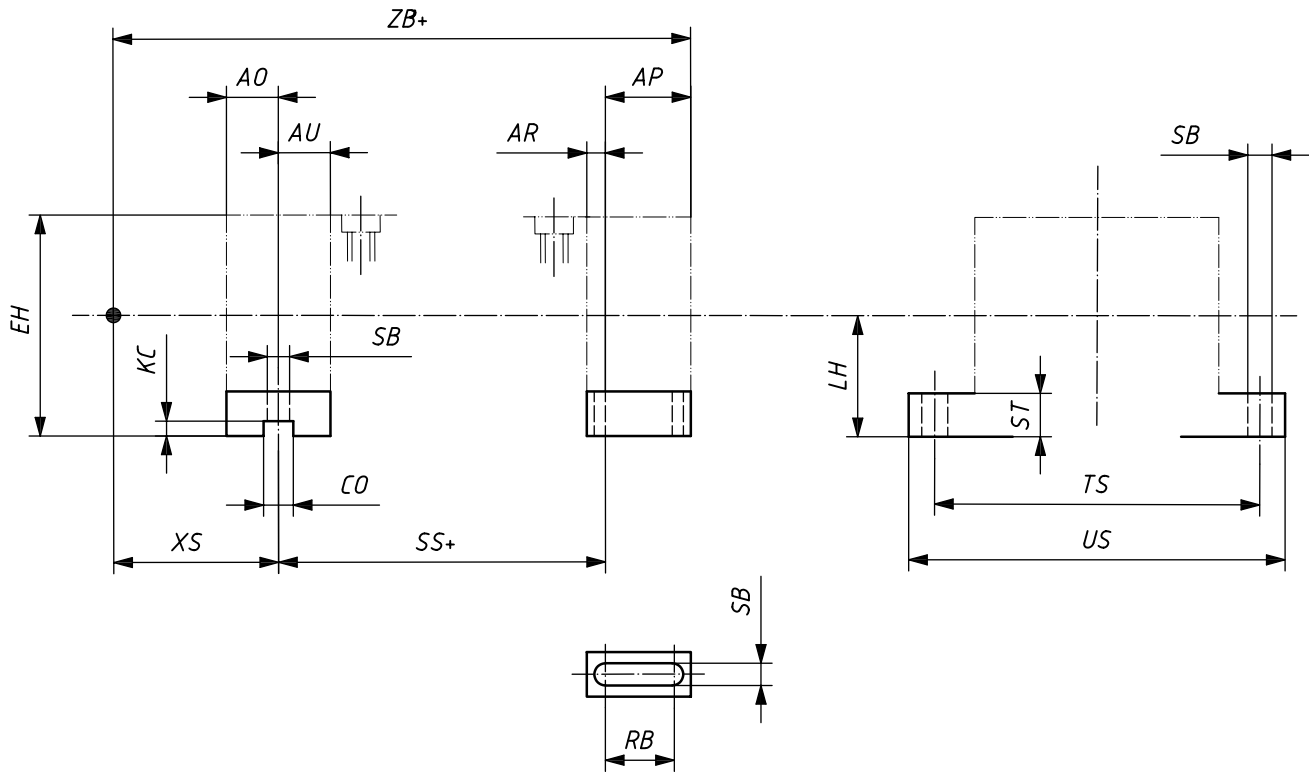

Figure 49 — MS 2: Side lugs

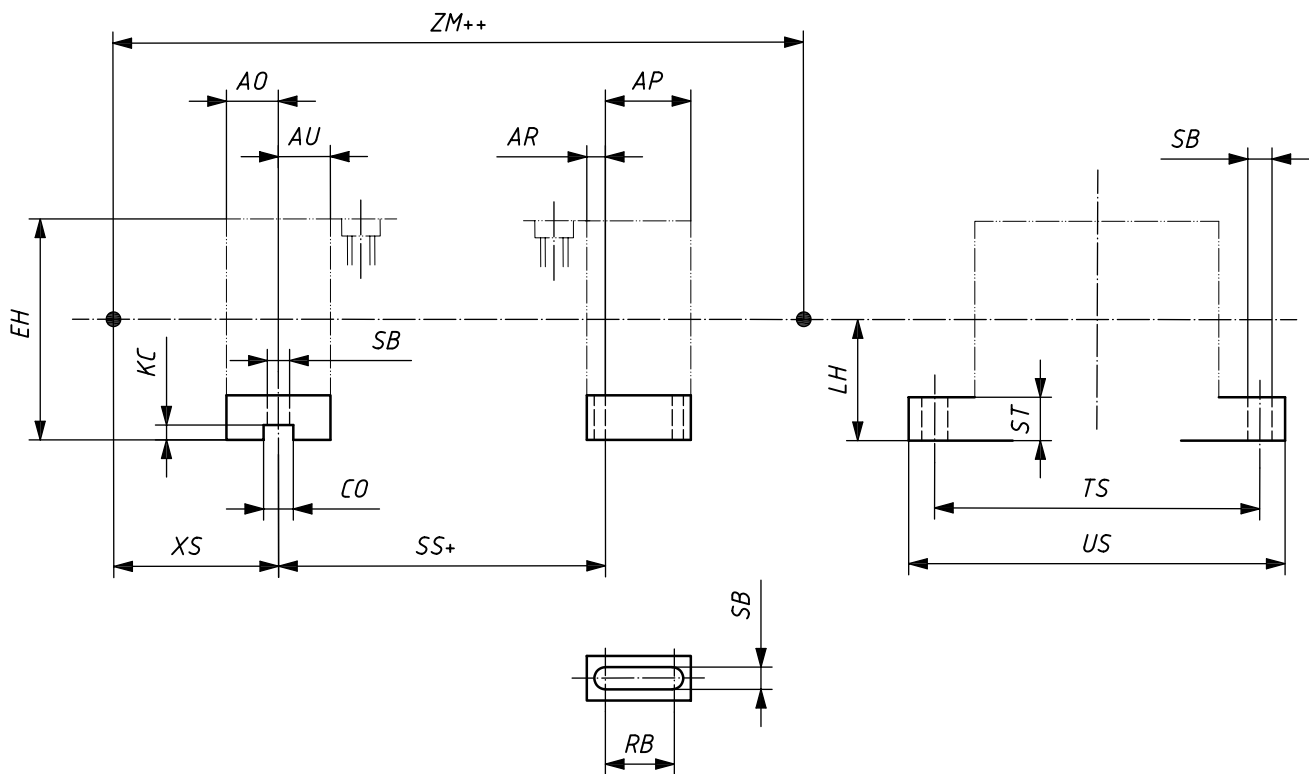

Figure 50 — MDS 2: Side lugs — Double rod

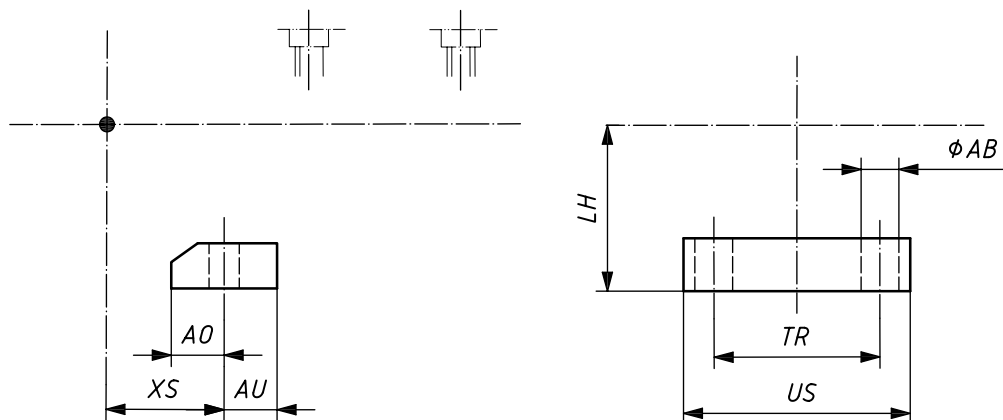

Figure 51 — MS 3: Head angle

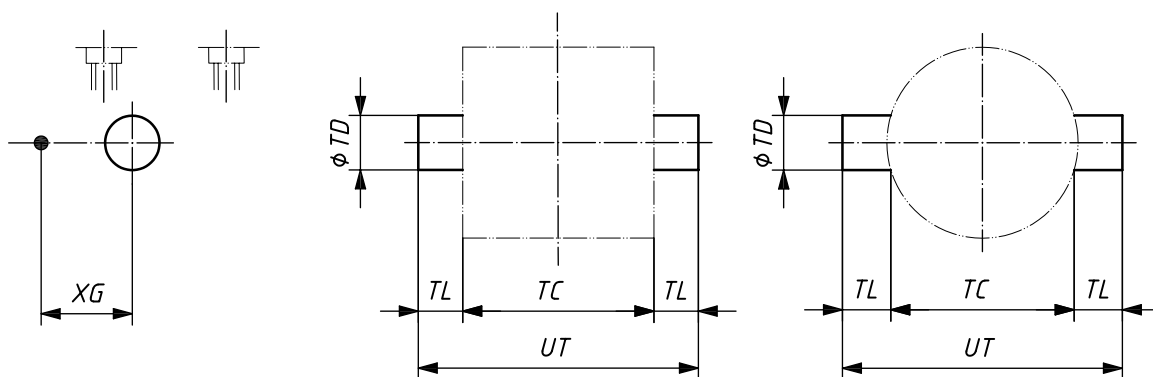

Figure 52 — MT 1: Head, integral trunnion (male)

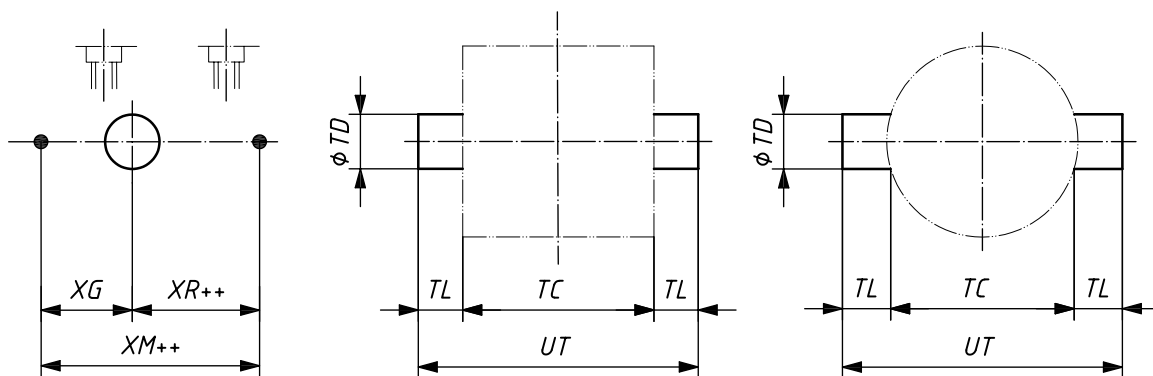

Figure 53 — MDT 1: Head, integral trunnion (male) — Double rod

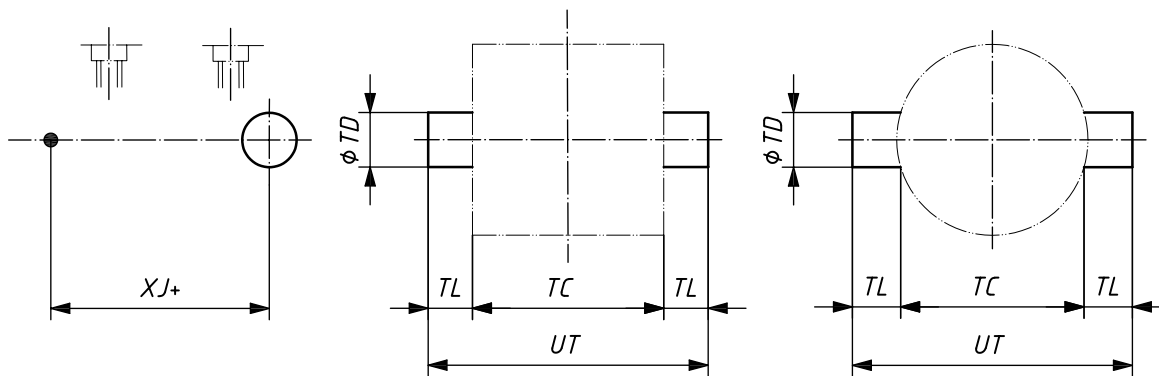

Figure 54 — MT 2: Cap, integral trunnion (male)

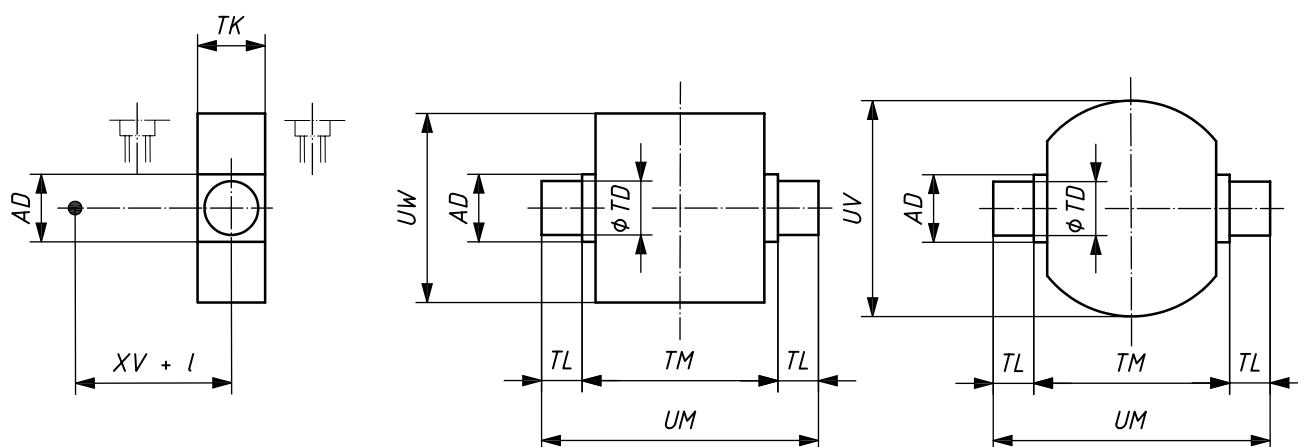

Figure 55 — MT 4: Intermediate trunnion (male) fixed or mobile

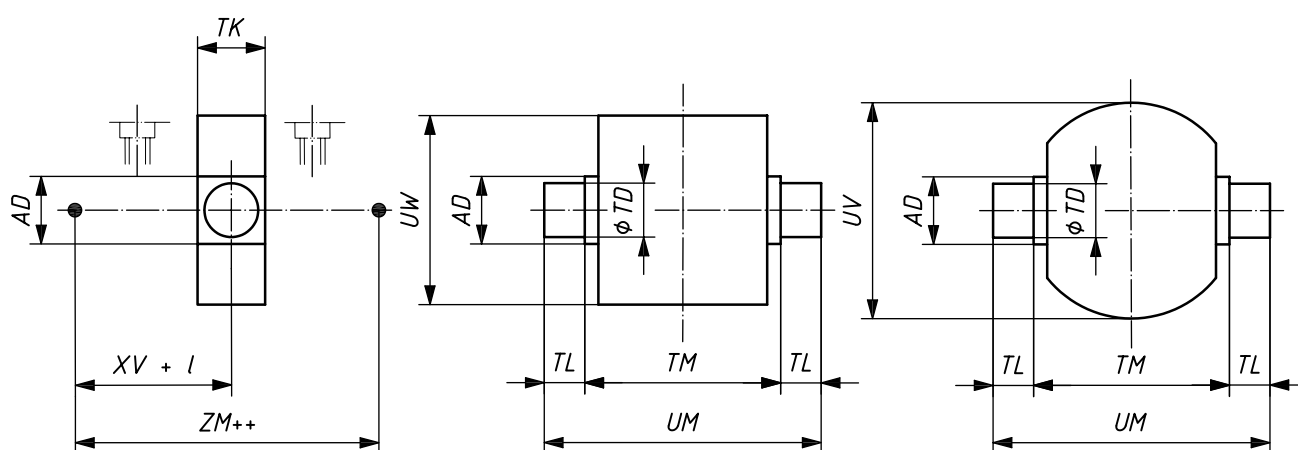

Figure 56 — MDT 4: Intermediate trunnion (male) fixed or mobile — Double rod

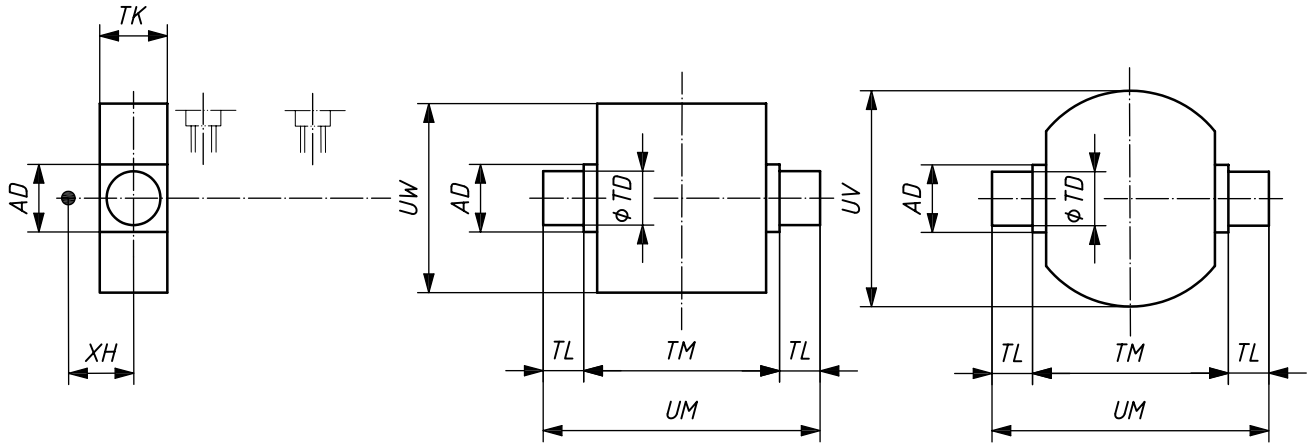

Figure 57 — MT 5: Head, detachable trunnion (male)

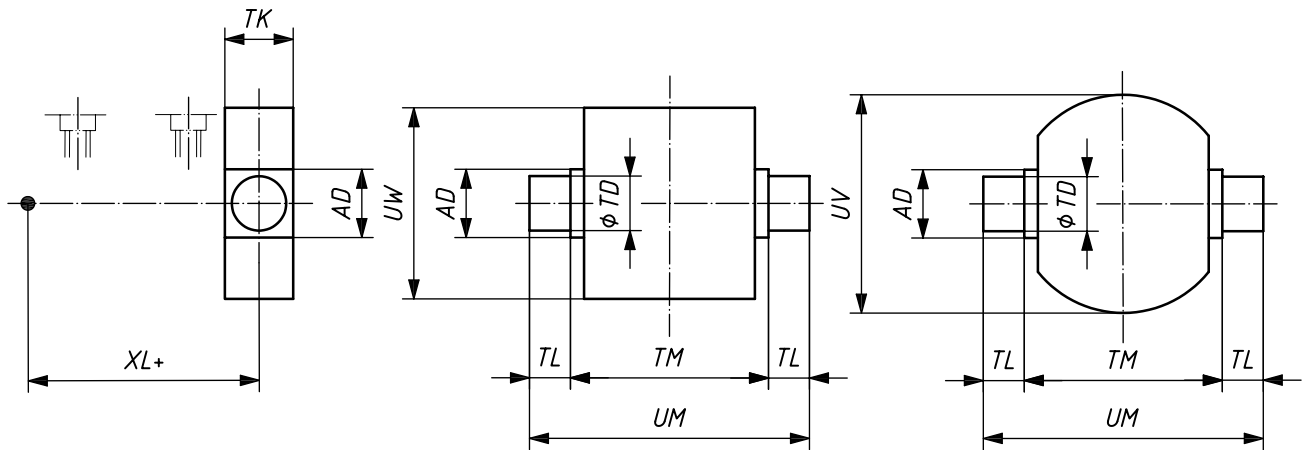

Figure 58 — MT 6: Cap, detachable trunnion (male)

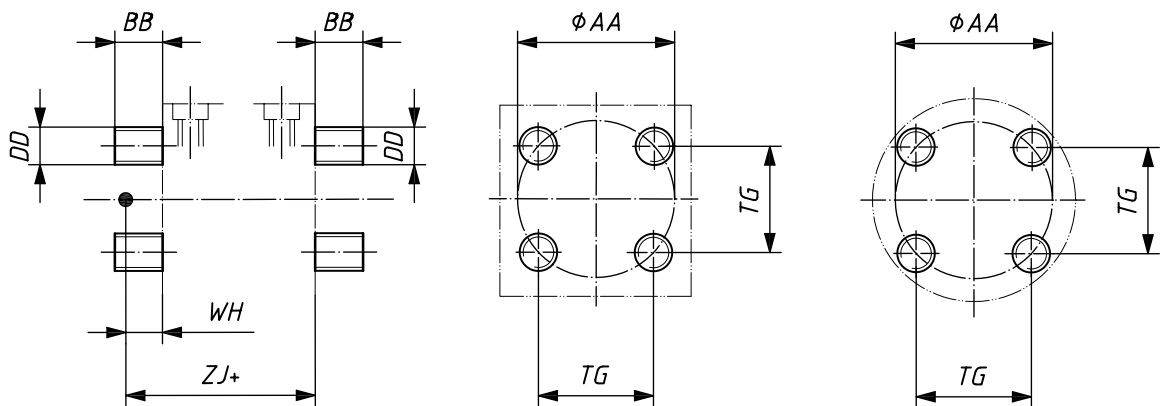

Figure 59 — MX 1: Both ends studs or tie rods extended

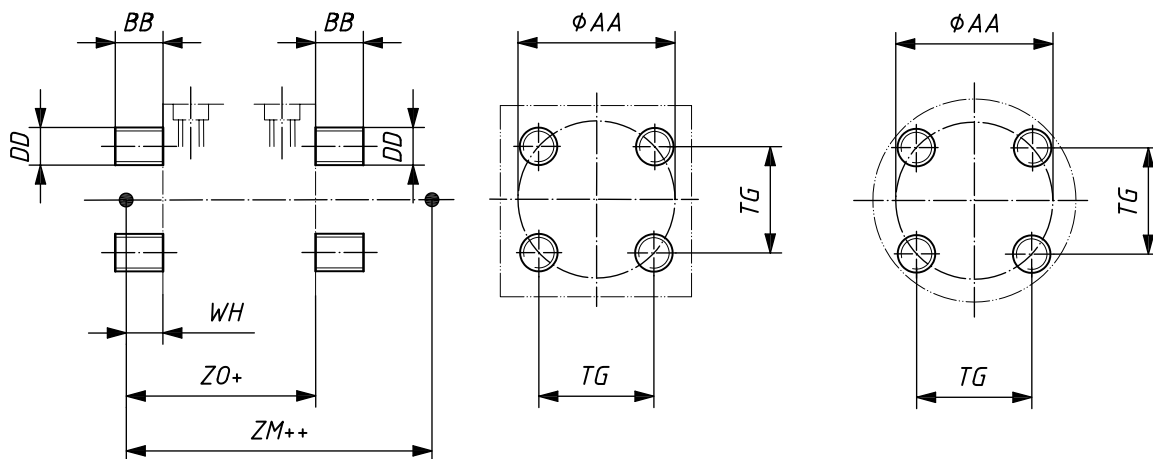

Figure 60 — MDX 1: Both ends studs or tie rods extended — Double rod

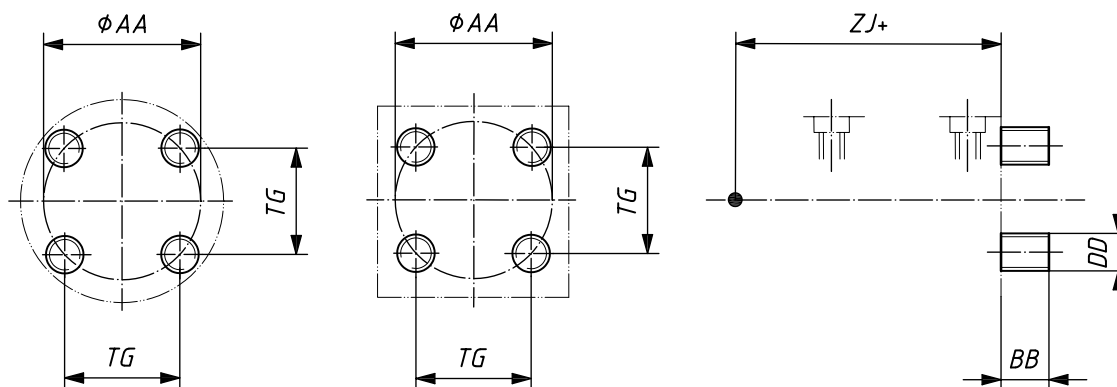

Figure 61 — MX 2: Cap studs or tie rods extended

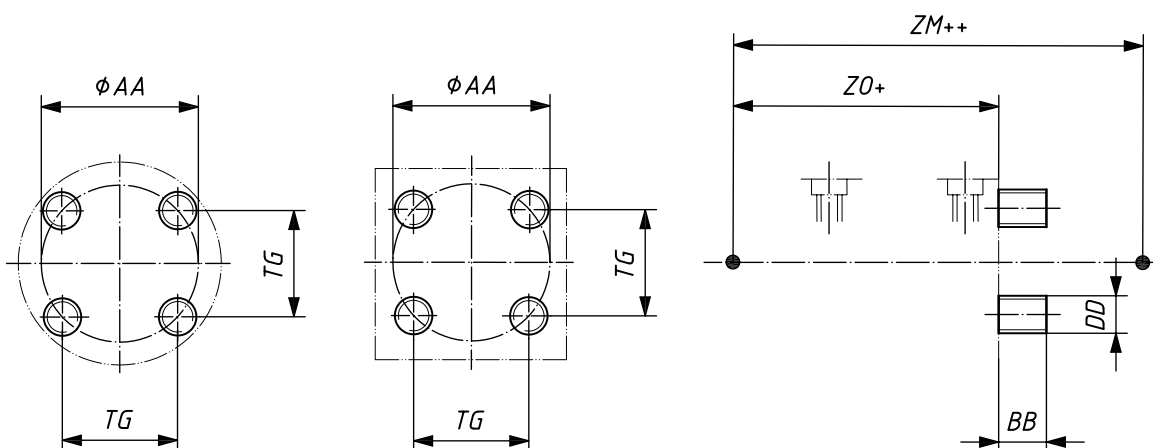

Figure 62 — MDX 2: Cap studs or tie rods extended — Double rod

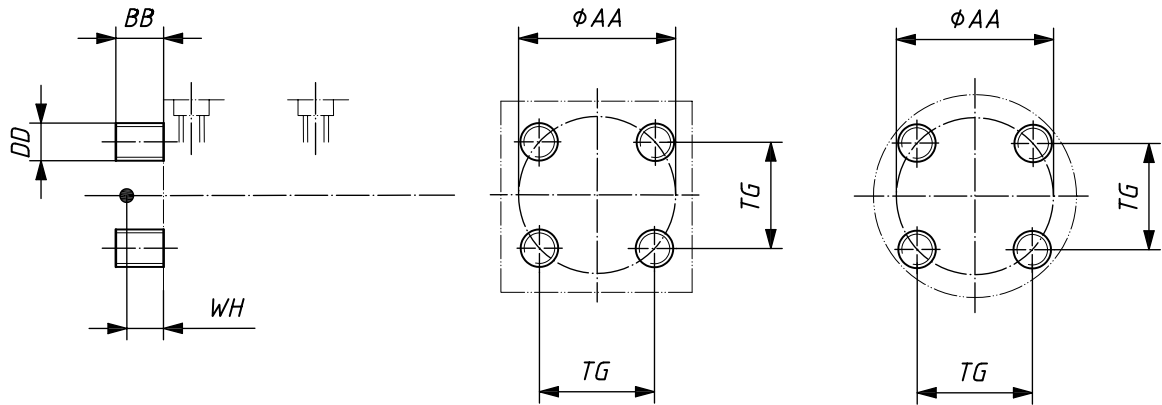

Figure 63 — MX 3: Head studs or tie rods extended

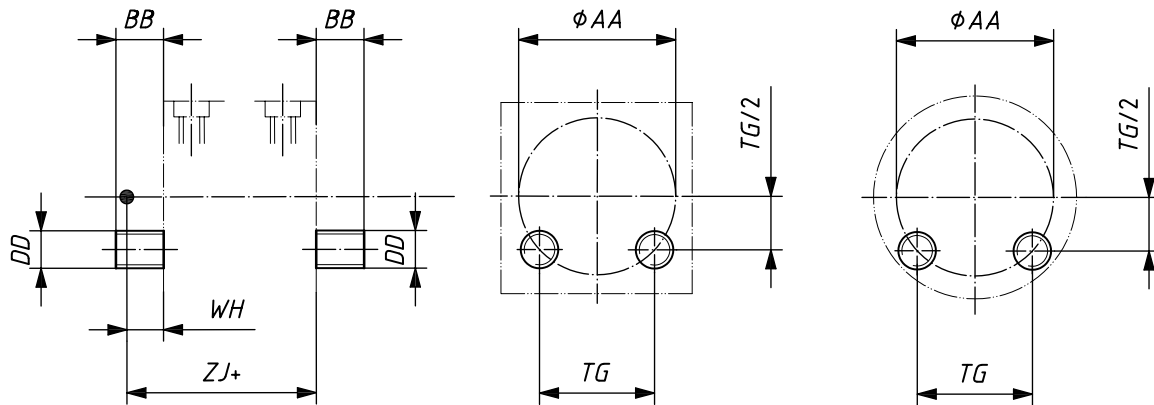

Figure 64 — MX 4: Both ends 2 studs or tie rods extended

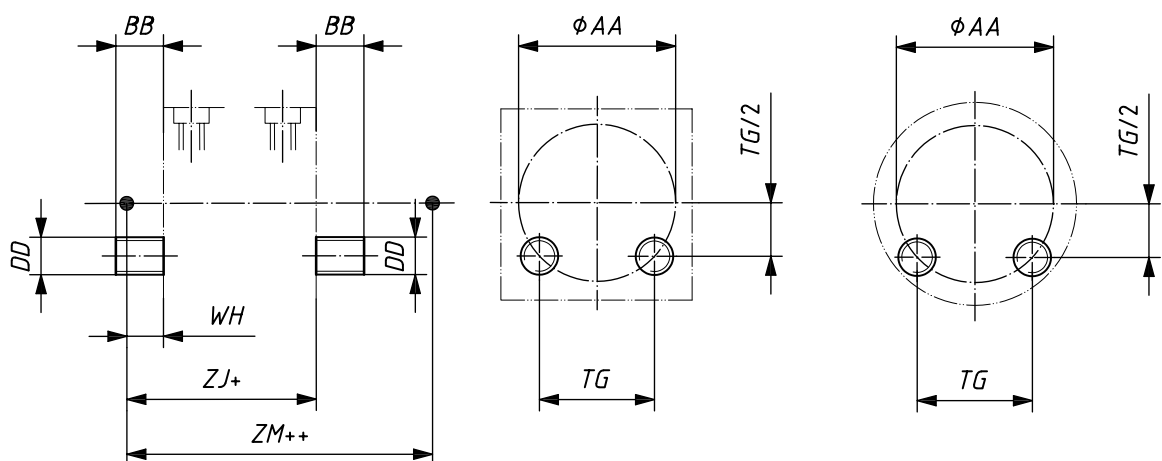

Figure 65 — MDX 4: Both ends 2 studs or tie rods extended — Double rod

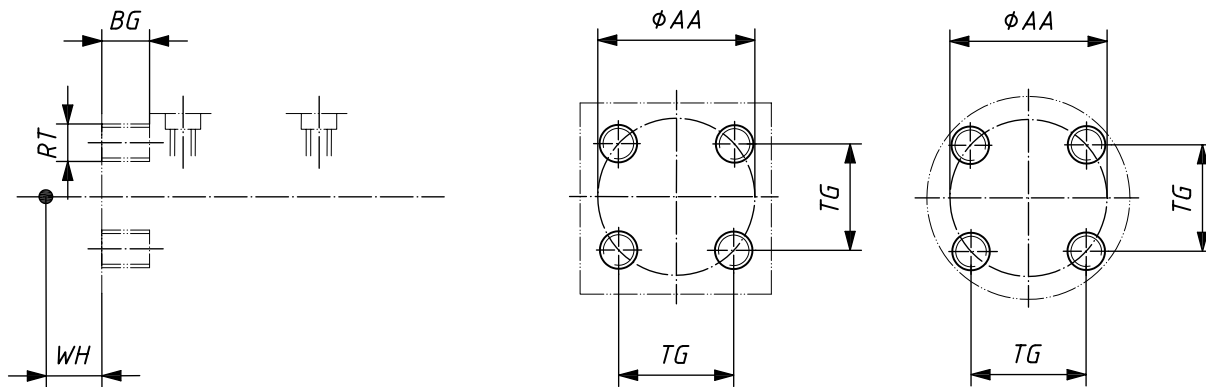

Figure 66 — MX 5: Head, tapped

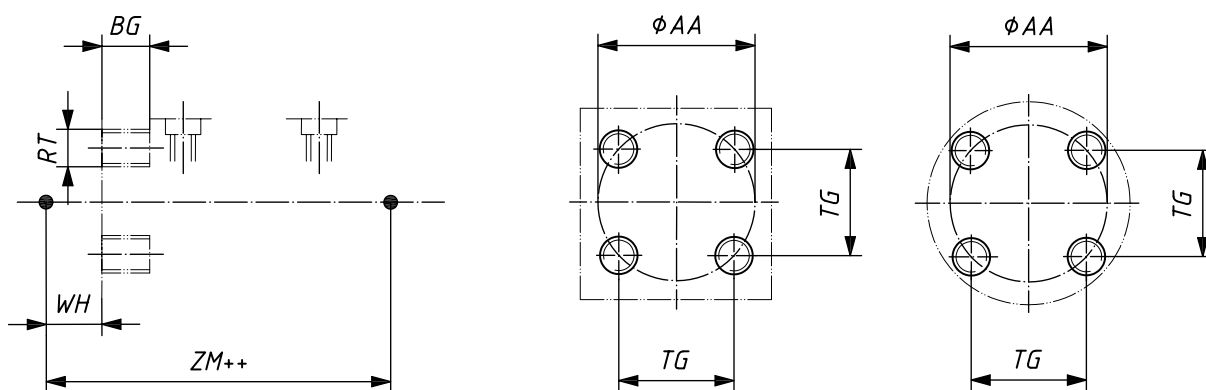

Figure 67 — MDX 5: Head, tapped — Double rod

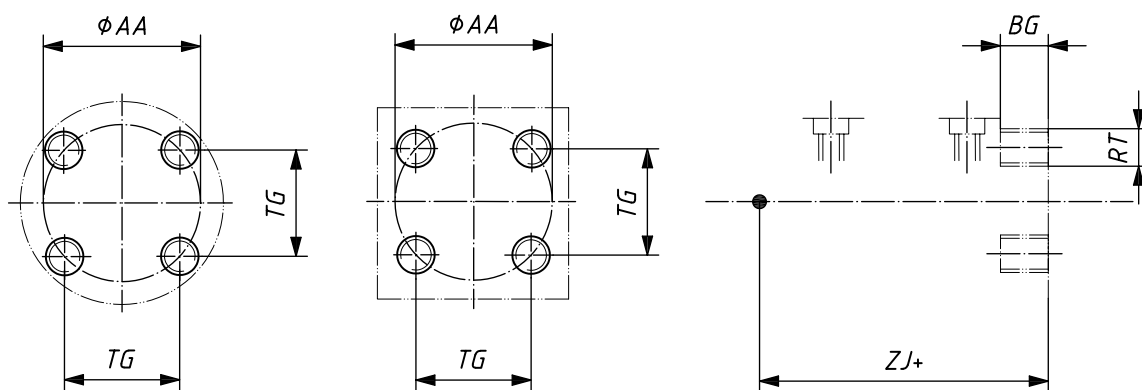

Figure 68 — MX 6: Cap, tapped

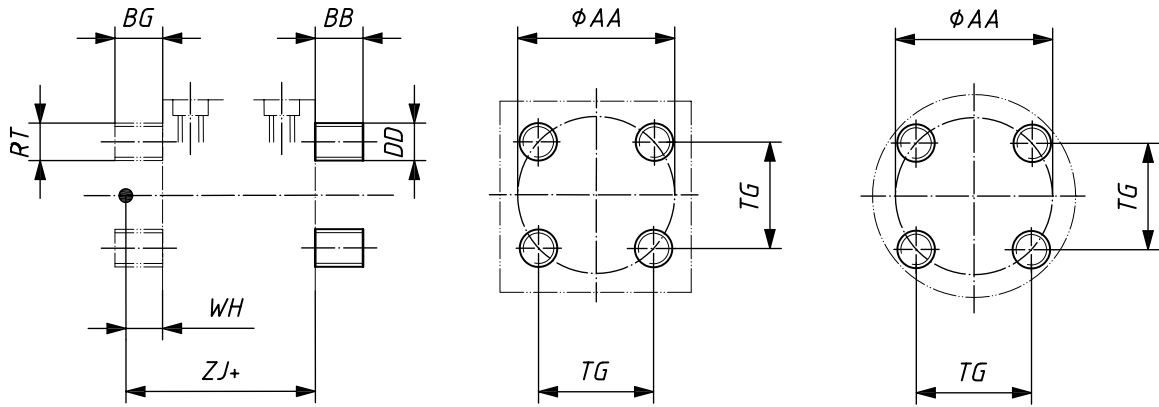

Figure 69 — MX 7: Head, tapped, and cap studs or tie rods extended

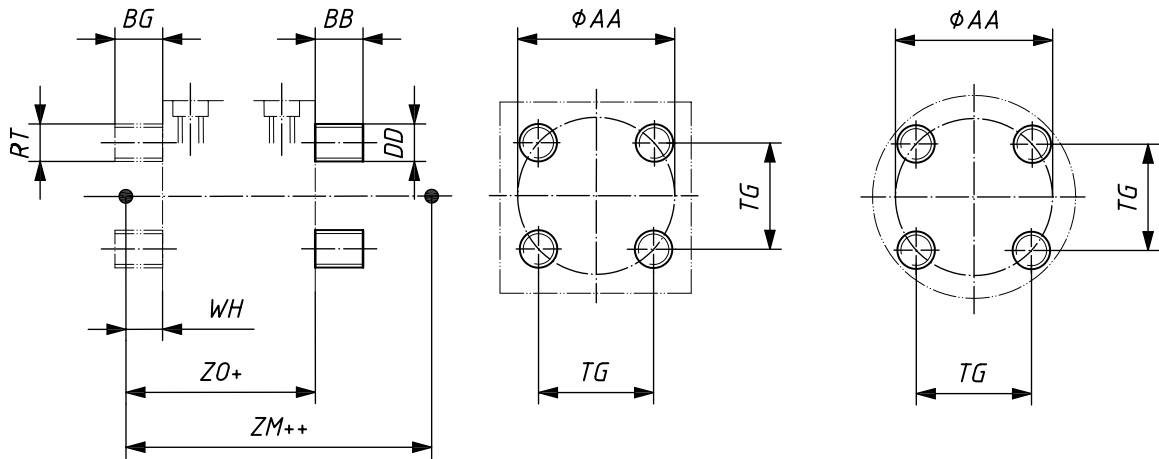

Figure 70 — MDX 7: Head, tapped, and cap studs or tie rods extended — Double rod

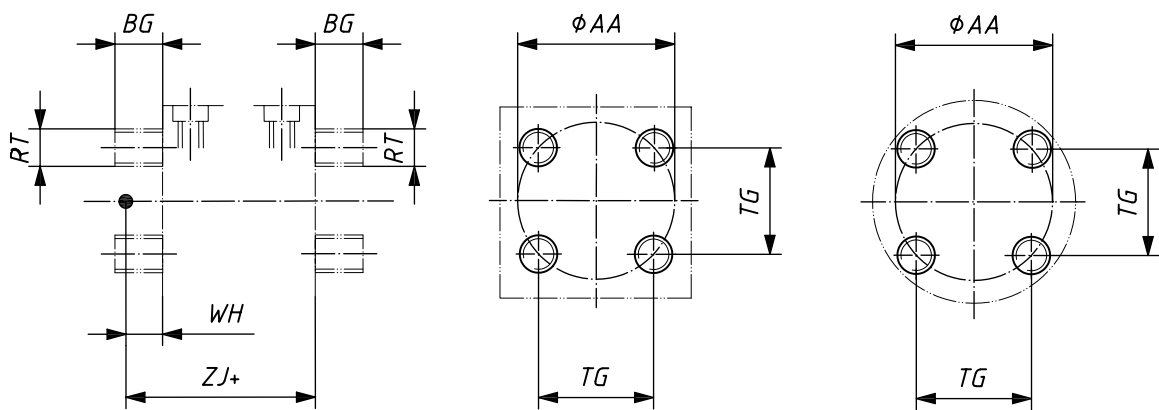

Figure 71 — MX 8: Head and cap, tapped

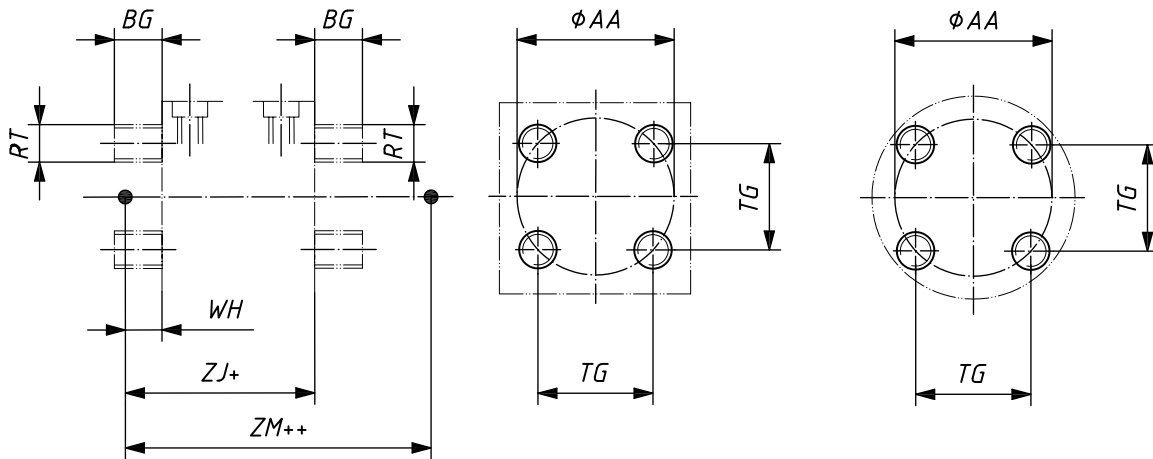

Figure 72 — MDX 8: Head and cap, tapped — Double rod

7 Identification code for accessory types

7.1 General

The identification code for cylinder accessory types consists of two letters and a number.

EXAMPLE

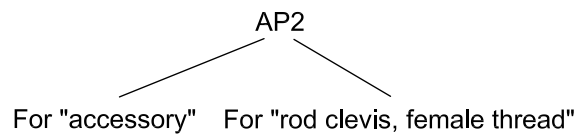

7.2 Accessory types

The accessory types defined in this International Standard are given with their identification code in Table 3.

Table 3 — Accessory types

Identification code	Description	Figure	With split pins	With rings	With locking plate	With key way	With centre hole
			- S ^a	- R ^a	- L ^a	- K ^a	- H ^a
AA4	Pivot pin, plain	84, 86, 90	- S	- R	- L		
AA6	Pivot pin, spherical bearing	85, 87, 88	- S	- R	- L		
AB2	Eye bracket, straight	77				- K	
AB3	Clevis bracket, in angle	79			- L	- K	- H
AB4	Clevis bracket, straight	78			- L	- K	- H
AB5	Clevis bracket, spherical eye, in angle	81			- L	- K	- H
AB6	Clevis bracket, spherical eye, straight	80			- L	- K	- H
AB7	Eye bracket, in angle	91				- K	
AF3	Rod flange, circular	82					
AL6	Locking plate for pivot pin	89					
AP2	Rod clevis, female thread	74			- L		
AP4	Rod eye plain, female thread	75					
AP6	Rod eye spherical, female thread	76					
AT4	Trunnion bracket	83					
^a See Figure 73.							

EXAMPLE **AB4-L-K** Accessory Clevis bracket, straight with locking plate and key way.

7.3 Letter codes of accessories according to accessory type

The letter code for accessories according to type is shown in Figure 73 to Figure 91.

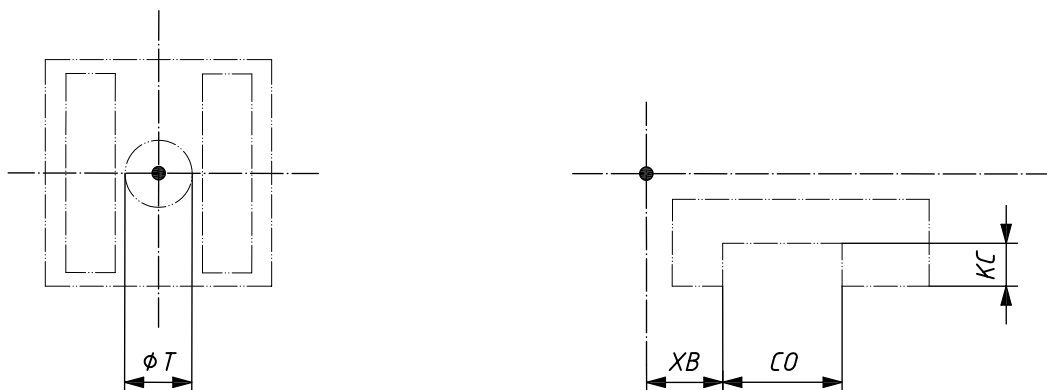

a) Centre hole through the mounting face - H

b) Key way - K

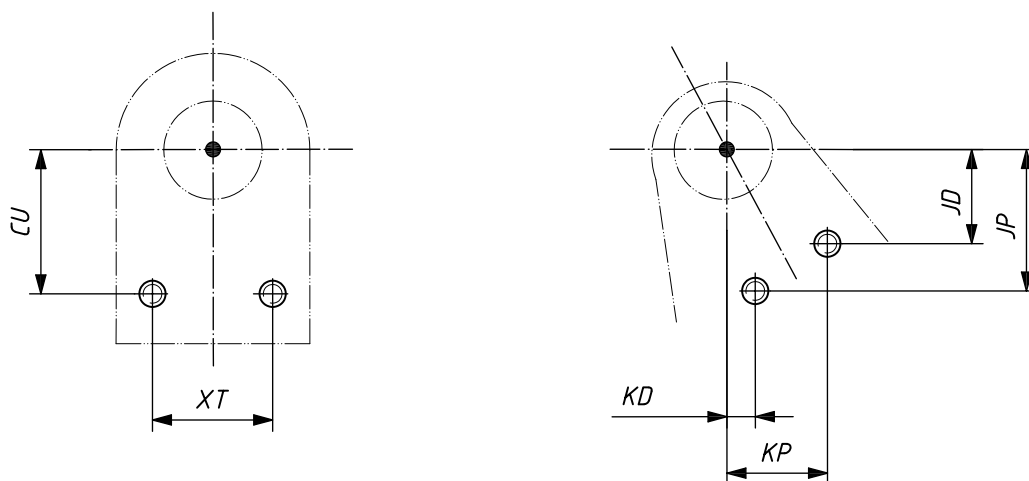

c) Mounting bolts for locking plate - L

Figure 73 — Optional function for accessories

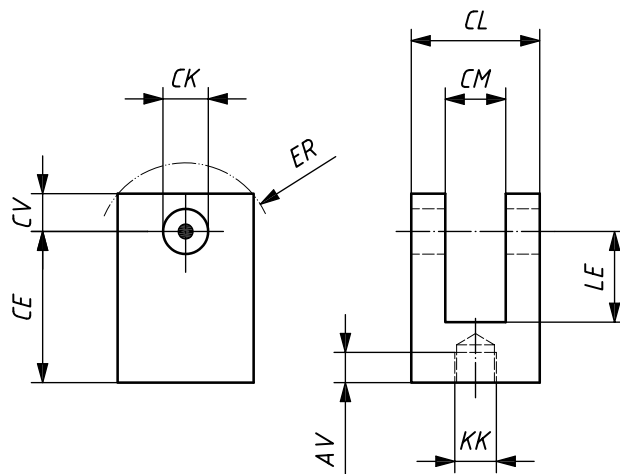

Figure 74 — AP2: Rod clevis, female thread

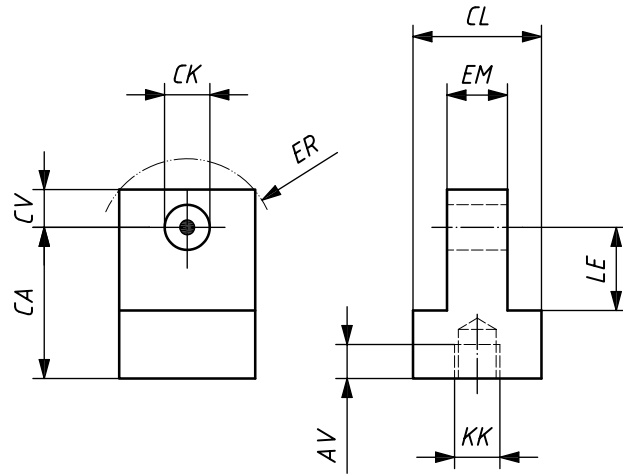

Figure 75 — AP4: Rod eye plain, female thread

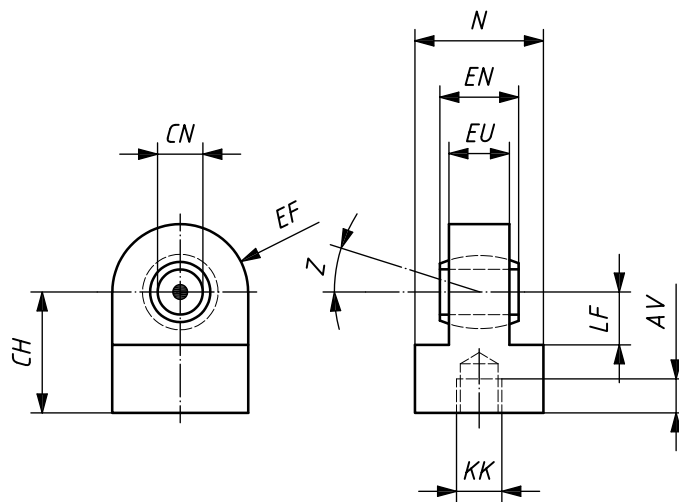

Figure 76 — AP6: Rod eye spherical, female thread

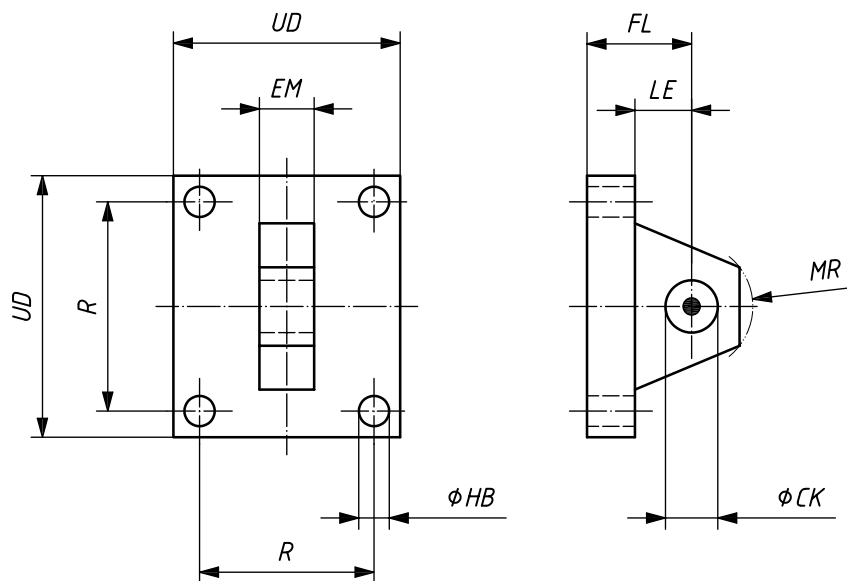

Figure 77 — AB2: Eye bracket, straight

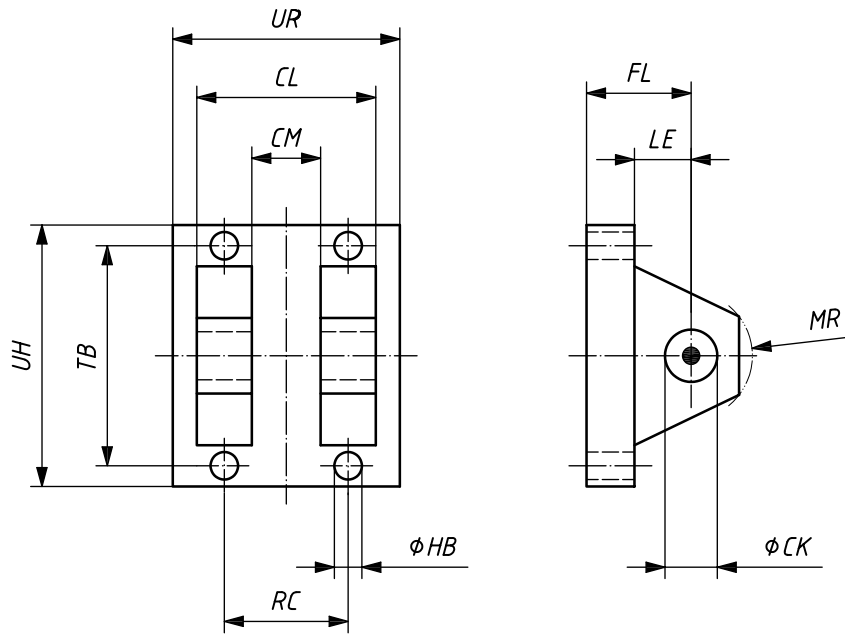

Figure 78 — AB4: Clevis bracket, straight

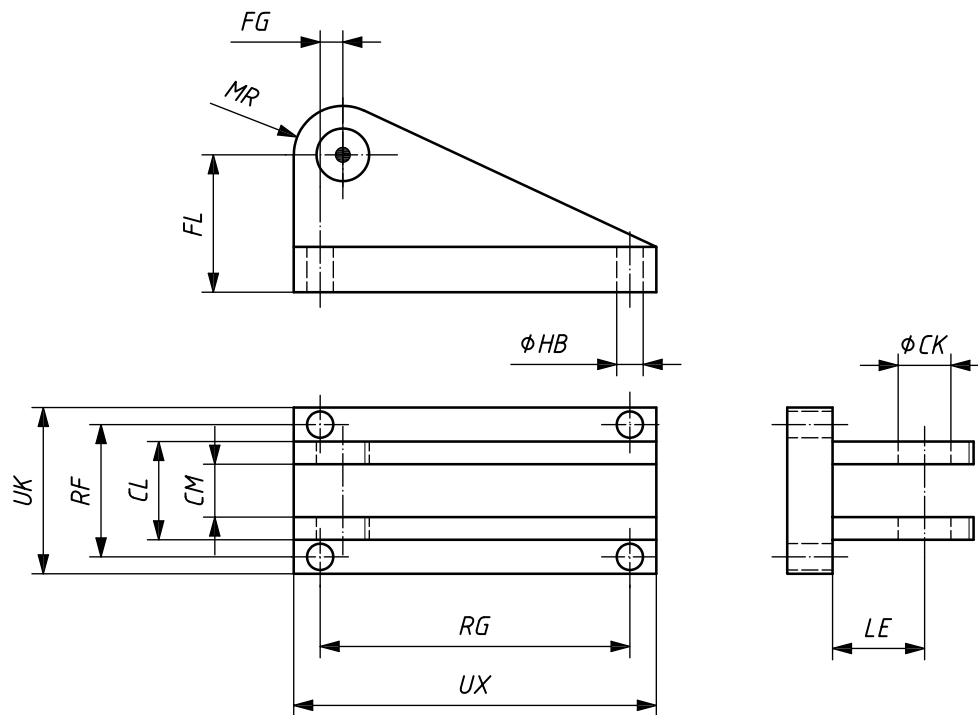

Figure 79 — AB3: Clevis bracket, in angle

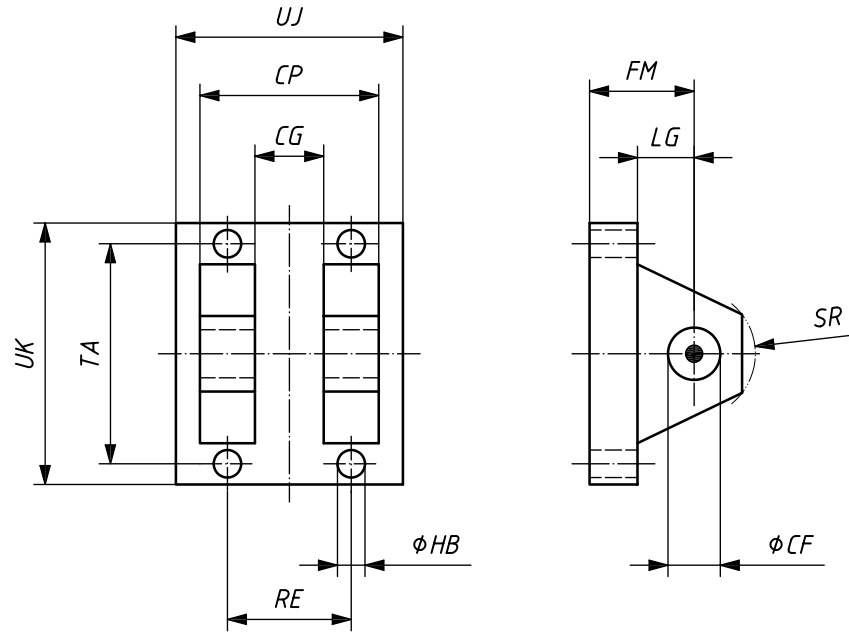

Figure 80 — AB6: Clevis bracket, spherical eye, straight

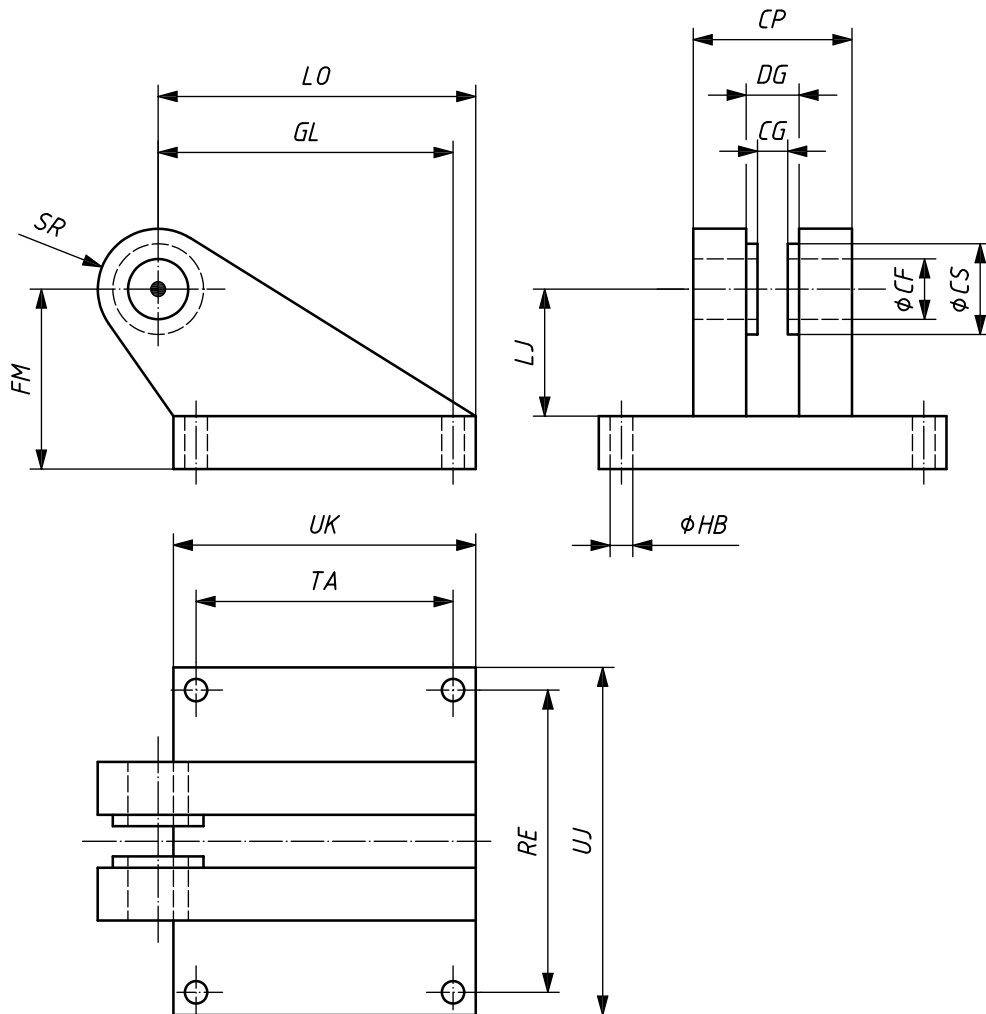

Figure 81 — AB5: Clevis bracket, spherical eye, in angle

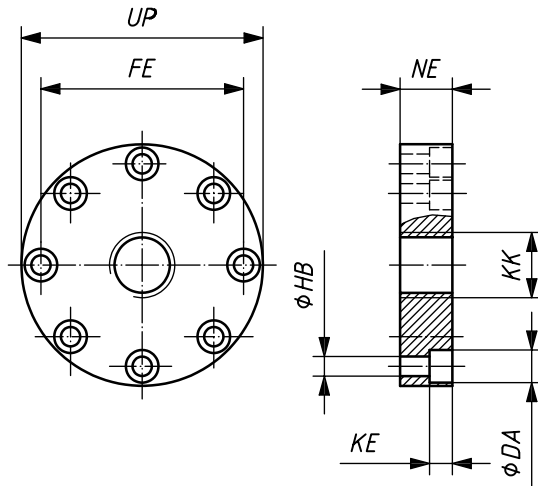

Figure 82 — AF3: Rod flange, circular

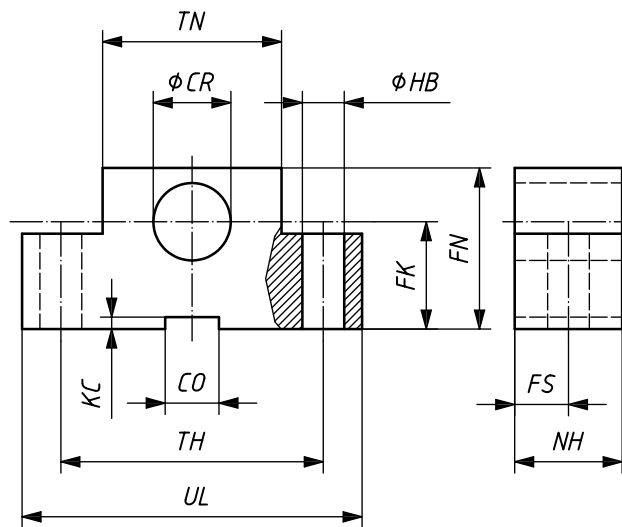

Figure 83 — AT4: Trunnion bracket

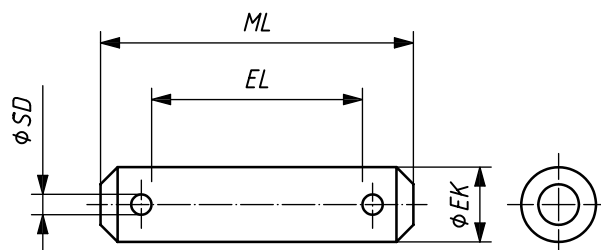

Figure 84 — AA4 - S: Pivot pin, plain, split pins

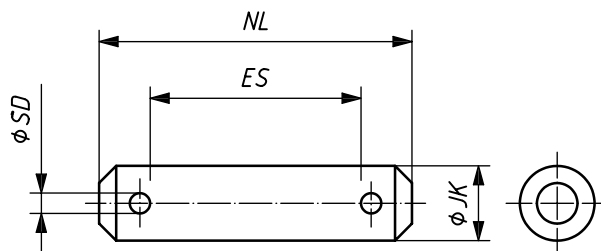

Figure 85 — AA6 - S: Pivot pin, spherical bearing, split pins

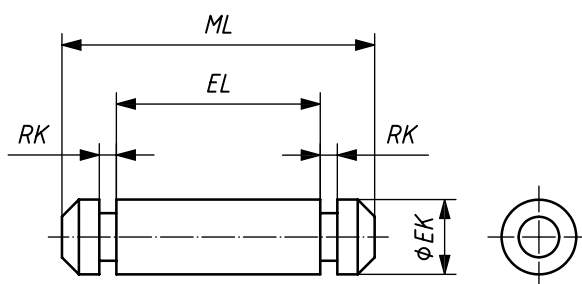

Figure 86 — AA4 - R: Pivot pin, plain, rings

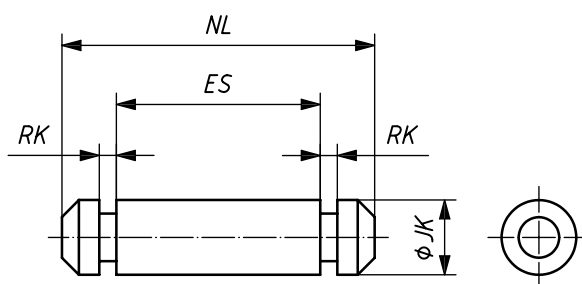

Figure 87 — AA6 - R: Pivot pin, spherical bearing, rings

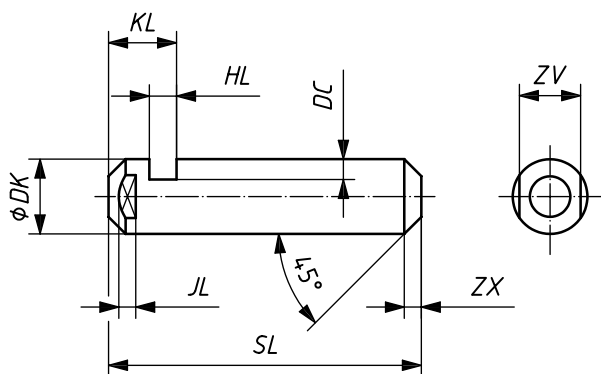
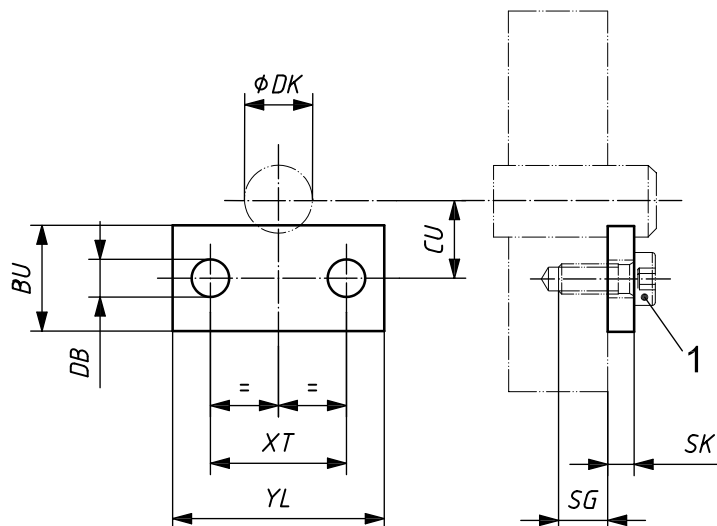

Figure 88 — AA6 - L: Pivot pin, spherical bearing, locking plate



Key
 1 screw

Figure 89 — AL6: Locking plate for pivot pin

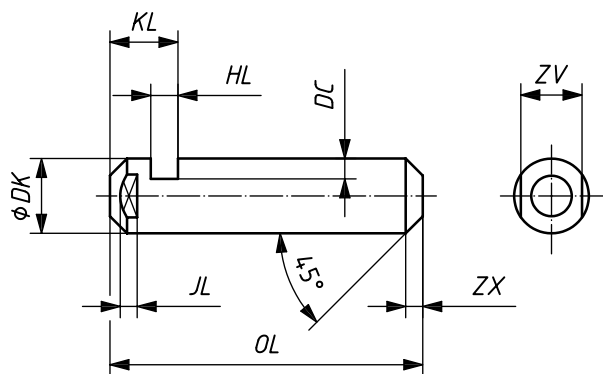

Figure 90 — AA4 - L: Pivot pin, plain, locking plate

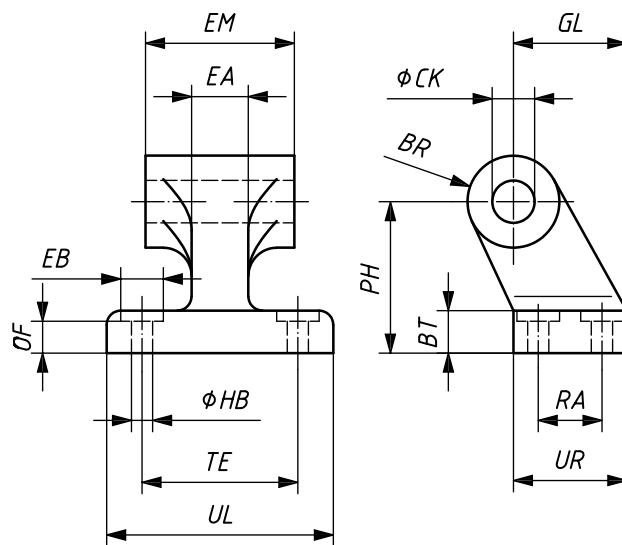

Figure 91 — AB7: Eye bracket, in angle

8 Designation of the position of the ports in round and square types

The designation of the port position can be described for the head and end cap of the cylinder.

— For square type cylinders, port position 1 to port position 4 can be selected as shown in Figure 92.

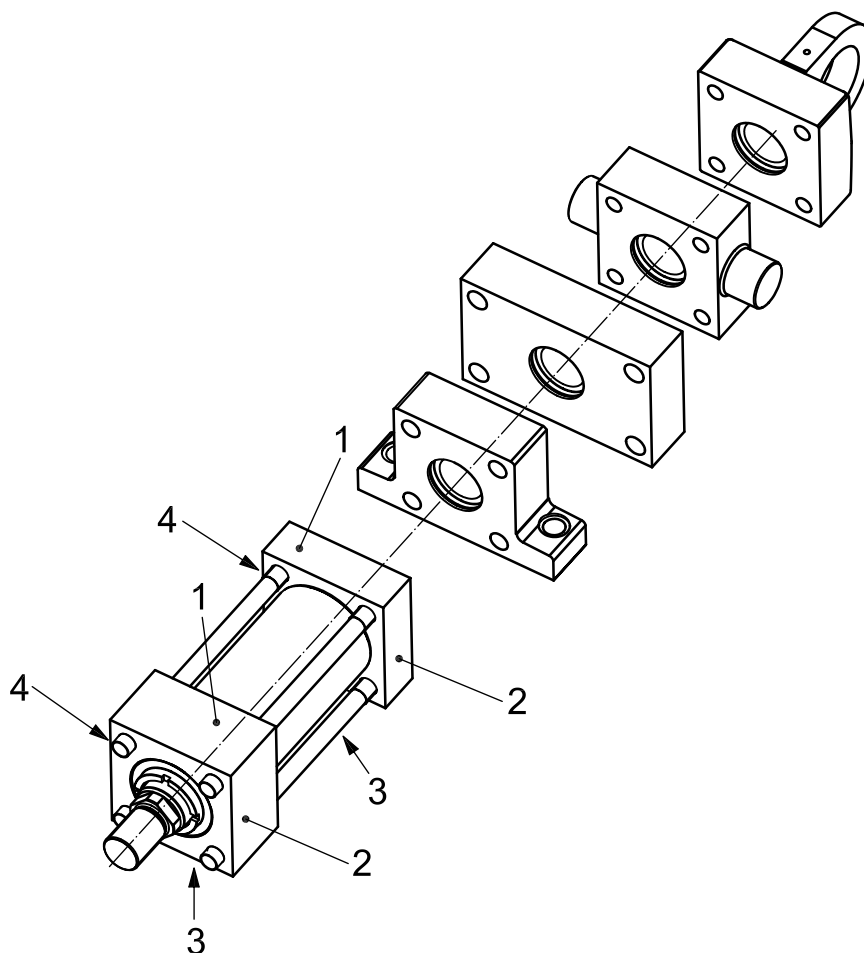

Figure 92 — Port position for square type cylinders

EXAMPLE 1 Example for the designation of the port position:

Port position 1

- For round type cylinders, port position 1 to port position 4 can be selected as shown in Figure 93 or as a sector between two positions.

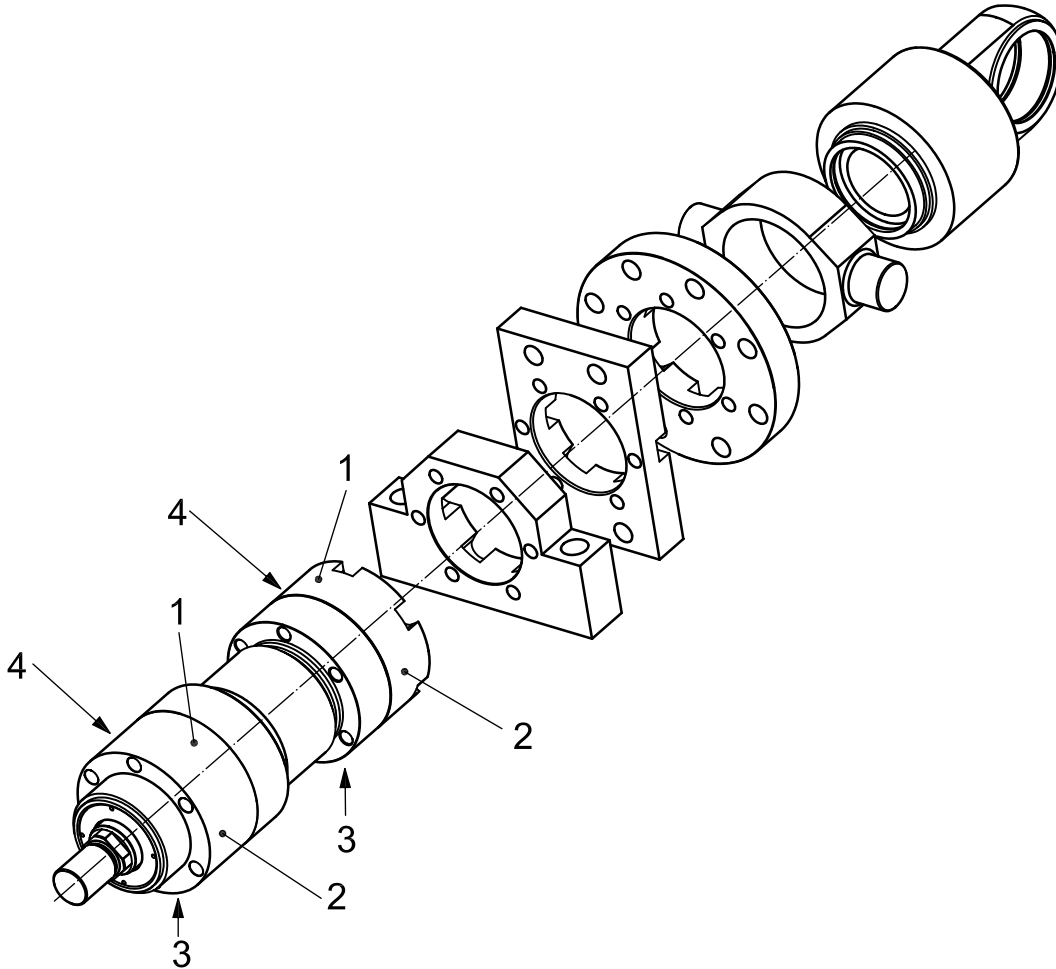

Figure 93 — Port position for round type cylinders

EXAMPLE 2 Example for the designation of the port position:

Port position between 1 and 2

9 Identification statement (Reference to this International Standard)

It is strongly recommended to manufacturers who have chosen to conform to this International Standard that the following statement be used in test reports, catalogues and sales literature:

“Cylinder mounting identification code in accordance with ISO 6099, *Fluid power systems and components — Cylinders — Identification code for mounting dimensions and mounting types.*”

Table 4 — Letter code listing

Symbol	Designation
<i>A</i>	Thread length of externally threaded rod end (rod end dimensions)
<i>B</i>	Diameter of head end pilot (general dimensions — MB 1 — MDB 1 — MB 2 — MDB 2 — ME 5 — MDE 5 — ME 7 — MDE 7 — ME 9 — MDE 9 — ME 11 — MDE 11)
<i>C</i>	
<i>D</i>	Ends outer diameter (general dimensions — MB 2 — MDB2)
<i>E</i>	End view dimensions (general dimensions — MB 1 — MDB 1 — ME 5 — MDE 5 — ME 6 — MF 1 — MDF 1 — MF 2)
<i>F</i>	Thickness of retainer plate (general dimensions — ME 5 — MDE 5 — ME 7 — MDE 7 — ME 9 — MDE 9 — ME 11 — MDE 11)
<i>G</i>	Head thickness (ME 5 — MDE 5 — ME 7 — MDE 7 — ME 9 — MDE 9 — ME 11 — MDE 11)
<i>H</i>	Increase dimension <i>E</i> to facilitate ports (general dimensions — MB 1 — MDB 1 — MB 2 — MDB 2)
<i>J</i>	Cap thickness (ME 6 — ME 8 — ME 10 — ME 12)
<i>K</i>	
<i>L</i>	Clearance around pivot axis (MP 1 — MP 2 — MP 3 — MP 4 — MP 7)
<i>M</i>	
<i>N</i>	Width of rod eye (AP4 — AP6)
<i>O</i>	
<i>P</i>	
<i>R</i>	Distance between mounting holes (AB2 — ME 5 — MDE 5 — ME 6 — MF 1 — MDF 1 — MF 2 — MF 5 — MDF 5 — MF 6 — ME 11 — MDE 11 — ME 12)
<i>S</i>	
<i>T</i>	Clearance hole through the mounting face (AB4 — AB6)
<i>U</i>	
<i>V</i>	
<i>W</i>	Distance between TRP ^a and mounting face (MF 1 — MDF 1 — MF 8)
<i>X</i>	
<i>Y</i>	Distance between TRP and head port (general dimensions)
<i>Z</i>	Tilting angle (AP 6 — MP 5 — MP 6)

Table 4 (continued)

Symbol 2nd letter	Designation
<i>A</i>	
<i>AA</i>	Pitch circle diameter of studs or tie rods (for reference only) (MX1 — MDX 1 — MX 2 — MDX 2 — MX 3 — MX 4 — MDX 4 — MX 5 — MDX 5 — MX 6 — MX 7 — MDX 7 — MX 8 — MDX 8)
<i>BA</i>	Diameter of cap pilot (general dimensions — MF 2 — MF 4)
<i>CA</i>	Distance between TRP and pivot axis (AP4)
<i>DA</i>	Counter sunk diameter for mounting screws (AF3)
<i>EA</i>	Rib thickness (AB7)
<i>FA</i>	
<i>GA</i>	
<i>HA</i>	
<i>JA</i>	
<i>KA</i>	Nut height, recessed (general dimensions)
<i>LA</i>	
<i>MA</i>	Flange diameter (rod end dimensions)
<i>NA</i>	
<i>OA</i>	
<i>PA</i>	
<i>RA</i>	Longitudinal distance (AB7)
<i>SA</i>	Longitudinal distance between mounting holes (MS 1)
<i>TA</i>	Distance between mounting holes (AB5 — AB6)
<i>UA</i>	
<i>VA</i>	Cap pilot extension (general dimensions)
<i>WA</i>	
<i>XA</i>	Distance between TRP and rear mounting holes (MS 1)
<i>YA</i>	
<i>ZA</i>	

Table 4 (continued)

Symbol 2nd letter	Designation
<i>B</i>	
<i>AB</i>	Mounting holes diameter (MS 1 — MDS 1 — MS 3)
<i>BB</i>	Length of stud or tie rod extension (MX 1 — MDX 1 — MX 2 — MDX 2 — MX 3 — MX 4 — MDX 4 — MX 7 — MDX 7)
<i>CB</i>	Clevis slot width (MP 1 — MP 2 — MP 7)
<i>DB</i>	Mounting holes for diameter locking plate (AL6)
<i>EB</i>	Diameter of mounting hole spot facing (AB7)
<i>FB</i>	Mounting holes diameter (MB 1 — MDB 1 — MB 2 — MDB 2 — ME 5 — MDE 5 — ME 6 — ME 7 — MDE 7 — ME 8 — ME 9 — MDE 9 — ME 10 — ME 11 — MDE 11 — ME 12 — MF 1 — MDF 1 — MF 2 — MF 3 — MDF 3 — MF 4 — MF 5 — MDF 5 — MF 6 — MF 7 — MDF 7 — MF 8)
<i>GB</i>	
<i>HB</i>	Mounting holes diameter (AB2 — AB3 — AB4 — AB5 — AB6 — AB7 — AF3 — AT4)
<i>JB</i>	
<i>KB</i>	Nut height, exposed (general dimensions)
<i>LB</i>	
<i>MB</i>	Groove diameter (rod end dimensions)
<i>NB</i>	
<i>OB</i>	
<i>PB</i>	
<i>RB</i>	
<i>SB</i>	Mounting holes diameter (MS 2 — MDS 2)
<i>TB</i>	Distance between mounting holes (AB4)
<i>UB</i>	Envelope distance (MP 1 — MP 2 — MP 7)
<i>VB</i>	
<i>WB</i>	Distance between TRP and mounting face (MF 7 — MDF 7)
<i>XB</i>	Distance between hole pin and key way (AB7 — AB5 — AB3)
<i>YB</i>	
<i>ZB</i>	Distance between TRP and cap end extremity (general dimensions)

Table 4 (continued)

Symbol 2nd letter <i>C</i>	Designation
<i>AC</i>	
<i>BC</i>	
<i>CC</i>	
<i>DC</i>	Groove depth clevis bracket (AA4-L — AA6-L)
<i>EC</i>	
<i>FC</i>	Pitch circle diameter (MF 3 — MDF 3 — MF 4 — MF 7 — MDF 7)
<i>GC</i>	
<i>HC</i>	
<i>JC</i>	
<i>KC</i>	Groove depth for key way (MS 2 — MDS2 — AB3 — AT4)
<i>LC</i>	
<i>MC</i>	
<i>NC</i>	
<i>OC</i>	
<i>PC</i>	
<i>RC</i>	Distance between mounting holes (AB4)
<i>SC</i>	
<i>TC</i>	Distance between trunnion bases (MT 1 — MDT 1 — MT 2 — MT 5 — MT 6)
<i>UC</i>	Envelope diameter (MF 3 — MDF 3 — MF 4 — MF 7 — MDF 7)
<i>VC</i>	Extension of pilot on flange (MF 7 — MDF 7)
<i>WC</i>	Distance between TRP and mounting face (MF 3 — MDF 3)
<i>XC</i>	Distance between TRP and pivot axis (MP 1 — MP 3)
<i>YC</i>	
<i>ZC</i>	

Table 4 (continued)

Symbol 2nd letter	Designation
<i>D</i>	
<i>AD</i>	Dimension of trunnion holder (MT 4 — MDT 4 — MT 5 — MT 6)
<i>BD</i>	
<i>CD</i>	Diameter of pivot hole (MP 1 — MP 2 — MP 3 — MP 4 — MP 7)
<i>DD</i>	Thread size (MX 1 — MDX 1 — MX 2 — MDX 2 — MX 3 — MX 4 — MDX 4 — MX 7 — MDX 7)
<i>ED</i>	
<i>FD</i>	Pitch circle diameter of holes (ME 7 — MDE 7 — ME 8 — MB 2 — MDB 2)
<i>GD</i>	
<i>HD</i>	
<i>JD</i>	
<i>KD</i>	
<i>LD</i>	
<i>MD</i>	
<i>ND</i>	
<i>OD</i>	Diameter for reducing length of centring RD (ME5 — MDE5 — ME7 — MDE7 — ME9 — MDE9 — ME11 — MDE11)
<i>PD</i>	
<i>RD</i>	Diameter of retainer plate (ME 5 — MDE 5 — ME 7 — MDE 7 — ME 9 — MDE 9 — ME 11 — MDE 11)
<i>SD</i>	Diameter of hole (AA4-S — AA6-S)
<i>TD</i>	Diameter of trunnion pins (MT 1 — MDT 1 — MT 2 — MT 4 — MDT 4 — MT 5 — MT 6)
<i>UD</i>	Envelope length (AB2)
<i>VD</i>	Pilot extension past retainer plate (general dimensions — MB 1 — MDB 1 — MB 2 — MDB 2 — ME 5 — MDE 5 — ME 7 — MDE 7 — ME 9 — MDE 9 — ME 11 — MDE 11)
<i>WD</i>	Diameter hole for hook wrench holes (rod end dimensions)
<i>XD</i>	Distance between TRP and pivot axis (MP 2 — MP 4)
<i>YD</i>	
<i>ZD</i>	

Table 4 (continued)

Symbol 2nd letter <i>E</i>	Designation
<i>AE</i>	Groove width (rod end dimensions)
<i>BE</i>	Mounting thread size (MR 3 — MDR 3 — MR 4)
<i>CE</i>	Distance between TRP and pivot axis (AP2)
<i>DE</i>	
<i>EE</i>	Port size (tapped, general dimensions)
<i>FE</i>	Pitch diameter of mounting holes (AF3)
<i>GE</i>	
<i>HE</i>	
<i>JE</i>	
<i>KE</i>	Depth of tapped mounting holes (AF3)
<i>LE</i>	Clearance around pivot axis (AB2 — AB3 — AB4 — AP2 — AP4) (rod end dimensions)
<i>ME</i>	Thickness of flange (MF 5 — MDF 5 — MF 6)
<i>NE</i>	Width of rod flange (AF3)
<i>OE</i>	
<i>PE</i>	
<i>RE</i>	Distance between mounting holes (AB5 — AB6)
<i>SE</i>	
<i>TE</i>	Transversal distance between mounting holes (AB7)
<i>UE</i>	Envelope diameter (ME 7 — MDE 7 — ME 8)
<i>VE</i>	Head end pilot extension past head (general dimensions, $VE = VD + F$)
<i>WE</i>	Distance between TRP and mounting face (MF 5 — MDF 5)
<i>XE</i>	
<i>YE</i>	
<i>ZE</i>	

Table 4 (continued)

Symbol 2nd letter	Designation
<i>F</i>	
<i>AF</i>	Thread length of tapped rod end (rod end dimensions)
<i>BF</i>	Length of mounting screw (MR 3 — MDR 3 — MR 4)
<i>CF</i>	Diameter of pivot hole (AB5 — AB6)
<i>DF</i>	
<i>EF</i>	Clearance radius of pivot axis (AP6)
<i>FF</i>	Flange port size (general dimensions)
<i>GF</i>	
<i>HF</i>	
<i>JF</i>	Thickness of flange (MF8)
<i>KF</i>	Thread size in tapped rod end (rod end dimensions)
<i>LF</i>	Clearance around pivot axis (AP6)
<i>MF</i>	Thickness of flange (MF 1 — MDF 1 — MF 2)
<i>NF</i>	Thickness of flange (MF 3 — MDF 3 — MF 4 — MF 7 — MDF 7)
<i>OF</i>	Distance from spot face to head of brackets (AB7)
<i>PF</i>	
<i>RF</i>	Distance of mounting holes (AB3)
<i>SF</i>	Width of wrench flat (rod end dimensions)
<i>TF</i>	Distance between mounting holes (ME 11 — MDE 11 — ME 12 — MF 1 — MDF 1 — MF 2 — MF 5 — MDF 5 — MF 6 — MF 8)
<i>UF</i>	Envelope length (MF1 — MDF 1 — MF 2 — MF 5 — MDF 5 — MF 6 — MF 8)
<i>VF</i>	
<i>WF</i>	Distance between TRP and head of mounting face (general dimensions — MB 1 — MDB 1 — MB 2 — MDB 2 — ME 5 — MDE 5 — ME 7 — MDE 7 — ME 9 — MDE 9 — ME 11 — MDE 11 — MR 3 — MDR 3)
<i>XF</i>	
<i>YF</i>	
<i>ZF</i>	Distance between TRP and back face of rear flange (MF 2)

Table 4 (continued)

Symbol 2nd letter <i>G</i>	Designation
<i>AG</i>	Dimension from TRP to shoulder of the piston (Figure 6)
<i>BG</i>	Depth of tapped mounting holes (MX 5 — MDX 5 — MX 6 — MX 7 — MDX 7 — MX 8 — MDX 8)
<i>CG</i>	Clevis bracket for spherical bearing slot (AB5 — AB6)
<i>DG</i>	Clearance around pivot axis (AB5)
<i>EG</i>	
<i>FG</i>	Distance between studs and mounting holes (AB3)
<i>GG</i>	
<i>HG</i>	
<i>JG</i>	
<i>KG</i>	
<i>LG</i>	Clearance around pivot axis (AB6)
<i>MG</i>	
<i>NG</i>	
<i>OG</i>	
<i>PG</i>	
<i>RG</i>	Distance of mounting bolts (AB3)
<i>SG</i>	Threaded depth for screw locking plate
<i>TG</i>	Distance between studs or tie rods (MX 1 — MDX 1 — MX 2 — MDX 2 — MX 3 — MX 4 — MDX 4 — MX 5 — MDX 5 — MX 6 — MX 7 — MDX 7 — MX 8 — MDX 8)
<i>UG</i>	Envelope length (ME 9 — MDE 9 — ME 10 — ME 11 — MDE 11 — ME 12)
<i>VG</i>	
<i>WG</i>	Depth of holes for hook wrench (rod end dimensions)
<i>XG</i>	Distance between TRP and trunnion axis (MT 1 — MDT 1)
<i>YG</i>	
<i>ZG</i>	Distance between mounting face and opposite rod shoulder (MDE 5 — MDE 7 — MDE 9 — MDE 11 — MDR 3)

Table 4 (continued)

Symbol 2nd letter	Designation
<i>H</i>	
<i>AH</i>	Centreline height (MS 1 — MDS 1)
<i>BH</i>	
<i>CH</i>	Distance between TRP and pivot axis (AP6)
<i>DH</i>	
<i>EH</i>	Height of the detachable side lugs (MS 2 — MDS 2)
<i>FH</i>	
<i>GH</i>	
<i>HH</i>	
<i>JH</i>	
<i>KH</i>	
<i>LH</i>	Centreline height (MS 2 — MDS 2 — MS 3)
<i>MH</i>	
<i>NH</i>	Thickness of trunnion bracket (AT4)
<i>OH</i>	Height of port face from centreline of cylinder (general dimensions)
<i>PH</i>	Centreline height of cylinder with mountings (AB7)
<i>RH</i>	
<i>SH</i>	
<i>TH</i>	Distance of mounting bolts (AT4)
<i>UH</i>	Envelope length (AB4)
<i>VH</i>	
<i>WH</i>	Distance between TRP and mounting face (general dimensions — MX 1 — MDX 1 — MX 3 — MX 4 — MDX 4 — MX 5 — MDX 5 — MX 7 — MDX 7 — MX 8 — MDX 8)
<i>XH</i>	Distance between TRP and trunnion axis (MT 5)
<i>YH</i>	
<i>ZH</i>	Distance between TRP and back face of rear flange (MF 6)

Table 4 (continued)

Symbol 2nd letter <i>J</i>	Designation
<i>AJ</i>	
<i>BJ</i>	
<i>CJ</i>	Diameter of pivot hole (rod end dimensions)
<i>DJ</i>	
<i>EJ</i>	
<i>FJ</i>	
<i>GJ</i>	
<i>HJ</i>	
<i>JJ</i>	
<i>KJ</i>	
<i>LJ</i>	Clearance around pivot axis (AB5)
<i>MJ</i>	
<i>NJ</i>	
<i>OJ</i>	
<i>PJ</i>	Distance between ports (general dimensions)
<i>RJ</i>	
<i>SJ</i>	
<i>TJ</i>	
<i>UJ</i>	Envelope length (AB5 — AB6)
<i>VJ</i>	
<i>WJ</i>	
<i>XJ</i>	Distance between TRP and trunnion axis (MT 2)
<i>YJ</i>	
<i>ZJ</i>	Distance between TRP and cap end (general dimensions — MB 1 — MB 2 — ME 6 — ME 8 — ME 10 — ME 12 — MR 4 — MX 1 — MX 2 — MX 4 — MX 6 — MX 7 — MX 8)

Table 4 (continued)

Symbol 2nd letter	Designation
<i>K</i>	
<i>AK</i>	
<i>BK</i>	
<i>CK</i>	Diameter of pivot holes (AB2 — AB3 — AB4 — AB7 — AP2 — AP4) (rod end dimensions)
<i>DK</i>	Pivot pin diameter (AA6-L — AA4-L — AL6)
<i>EK</i>	Pivot pin diameter (AA4-S-R)
<i>FK</i>	Distance between mounting face and pivot axis (AT4)
<i>GK</i>	Thread size for mounting bolts (AB5)
<i>HK</i>	
<i>JK</i>	Pivot pin diameter (AA6-S-R)
<i>KK</i>	Internal or external thread size (rod end dimensions — AP 2 — AP 4 — AP 6 — AF 3)
<i>LK</i>	
<i>MK</i>	
<i>NK</i>	
<i>OK</i>	
<i>PK</i>	Distance between ports (general dimensions)
<i>RK</i>	
<i>SK</i>	Thickness of locking plate (AL6)
<i>TK</i>	Thickness of detachable trunnion (MT 4 — MDT 4 — MT 5 — MT 6)
<i>UK</i>	Envelope length (AB3 — AB5 — AB6)
<i>VK</i>	
<i>WK</i>	Distance between TRP and axis of holes for hook wrench (rod end dimensions)
<i>XK</i>	
<i>YK</i>	
<i>ZK</i>	Distance between TRP and opposite head face (general dimensions — MDB 1 — MDB 2)

Table 4 (continued)

Symbol 2nd letter <i>L</i>	Designation
<i>AL</i>	Cylinder bore (general dimensions)
<i>BL</i>	
<i>CL</i>	Mounting clevis lengths (AB3 — AB4 — AP2)
<i>DL</i>	Spherical eye bracket mounting face to pivot axis (MP 6)
<i>EL</i>	Mounting length of pin (AA4-S-R)
<i>FL</i>	Mounting face to pivot axis (MP 2 — MP 4 — MP 7 — AB2 — AB3 — AB4)
<i>GL</i>	Distance between mounting holes and pivot bolt (AB5 — AB7)
<i>HL</i>	Clevis slot width for locking plate (AA6-L — AA4-L)
<i>JL</i>	Length of nut flat (AA6-L — AA4-L)
<i>KL</i>	Distance of clevis slot (AA6-L — AA4-L)
<i>LL</i>	
<i>ML</i>	Length of pivot pin, plain (AA4-S-R)
<i>NL</i>	Length of pivot pin, spherical bearing (AA6-R-S)
<i>OL</i>	Length of pivot pin, plain locking plate (AA4-L)
<i>PL</i>	Distance between cap port and cap end (general dimensions)
<i>RL</i>	
<i>SL</i>	Length of pivot pin, spherical bearing locking plate (AA6-L)
<i>TL</i>	Length of trunnion pins (MT 1 — MDT 1 — MT 2 — MT 4 — MDT 4 — MT 5 — MT 6)
<i>UL</i>	Envelope length (AB7 — AT4)
<i>VL</i>	Length of pilot diameter (ME 5 — MDE 5)
<i>WL</i>	Length of wrench flats (rod end dimensions)
<i>XL</i>	Distance between TRP and trunnion axis (MT 6)
<i>YL</i>	Length of locking plate (AL6)
<i>ZL</i>	Distance between TRP and opposite head end extremity except rod (general dimensions)

Table 4 (continued)

Symbol 2nd letter	Designation
<i>M</i>	
<i>AM</i>	
<i>BM</i>	
<i>CM</i>	Rod clevis slot width, clevis bracket slot width (AB3 — AB4 — AP2)
<i>DM</i>	
<i>EM</i>	Eye bracket eye width, rod eye, plain eye width (AB2 — AB7 — AP4) (rod end dimensions)
<i>FM</i>	Mounting face to pivot axis (AB5 — AB6)
<i>GM</i>	
<i>HM</i>	
<i>JM</i>	
<i>KM</i>	
<i>LM</i>	
<i>MM</i>	Rod diameter, <i>d</i> (general dimensions)
<i>NM</i>	
<i>OM</i>	
<i>PM</i>	Distance between far port and far end (general dimensions)
<i>RM</i>	
<i>SM</i>	Longitudinal distance between mounting holes (MDS 1)
<i>TM</i>	Distance between trunnion bases (MT 4 — MDT 4)
<i>UM</i>	Envelope distance (MT 4 — MDT 4)
<i>VM</i>	
<i>WM</i>	
<i>XM</i>	Distance between TRP and opposite holes (MDS 1)
<i>YM</i>	
<i>ZM</i>	Distance between TRP and opposite rod shoulder (general dimensions — MDB 1 — MDB 2 — MDS 1 — MDS 2 — MDX 1 — MDX 7 — MDX 8)

Table 4 (continued)

Symbol 2nd letter	Designation
<i>N</i>	
<i>AN</i>	
<i>BN</i>	
<i>CN</i>	Diameter of pivot holes (AP6)
<i>DN</i>	
<i>EN</i>	Spherical bearing width (AP6)
<i>FN</i>	Overall height of trunnion bracket (AT4)
<i>GN</i>	
<i>HN</i>	
<i>JN</i>	
<i>KN</i>	
<i>LN</i>	
<i>MN</i>	
<i>NN</i>	
<i>ON</i>	
<i>PN</i>	
<i>RN</i>	
<i>SN</i>	
<i>TN</i>	
<i>UN</i>	
<i>VN</i>	
<i>WN</i>	
<i>XN</i>	Distance between TRP and pivot axis (MP 6)
<i>YN</i>	
<i>ZN</i>	Distance between mounting face and opposite TRP (MDF 3)

Table 4 (continued)

Symbol 2nd letter	Designation
<i>O</i>	
<i>AO</i>	Distance from mounting holes to cylinder's mounting face (MS 1 — MDS 1 — MS 2 — MDS 2 — MS 3)
<i>BO</i>	
<i>CO</i>	Width of key way (MS 2 — MDS 2 — AB3 — AT4)
<i>DO</i>	
<i>EO</i>	
<i>FO</i>	Distance between clevis slot and pivot axis (AB3)
<i>GO</i>	Distance between clevis slot and mounting holes axis (MS 2 — MDS 2)
<i>HO</i>	
<i>JO</i>	Distance of mounting bolts for locking plate (AB5)
<i>KO</i>	Distance of mounting bolts for locking plate (AB5)
<i>LO</i>	Distance for pin hole from envelope length (AB5)
<i>MO</i>	
<i>NO</i>	
<i>OO</i>	
<i>PO</i>	
<i>RO</i>	
<i>SO</i>	
<i>TO</i>	Distance between mounting holes (MB 1 — MDB 1 — ME 5 — MDE 5 — ME 6)
<i>UO</i>	Envelope length (ME 5 — MDE 5 — ME 6)
<i>VO</i>	
<i>WO</i>	
<i>XO</i>	Distance between TRP and pivot axis (MP 5)
<i>YO</i>	
<i>ZO</i>	Distance between TRP and mounting face (MDX 1 — MDX 2 — MDX 4 — MDX 7 — MDX 8)

Table 4 (continued)

Symbol 2nd letter <i>P</i>	Designation
<i>AP</i>	Distance from mounting holes to cylinder mounting face (MS 2 — MDS 2)
<i>BP</i>	
<i>CP</i>	Mounting clevis envelope length (AB5 — AB6)
<i>DP</i>	
<i>EP</i>	Eye width (MP 5 — MP 6)
<i>FP</i>	
<i>GP</i>	
<i>HP</i>	
<i>JP</i>	Distance of mounting bolts for locking plate (AB5)
<i>KP</i>	Distance of mounting bolts for locking plate (AB5)
<i>LP</i>	
<i>MP</i>	
<i>NP</i>	
<i>OP</i>	
<i>PP</i>	
<i>RP</i>	
<i>SP</i>	
<i>TP</i>	
<i>UP</i>	Outside diameter for rod flange (AF3)
<i>VP</i>	
<i>WP</i>	
<i>XP</i>	
<i>YP</i>	
<i>ZP</i>	Distance between TRP and back face of rear flange (MF 4)

Table 4 (continued)

Symbol 2nd letter <i>R</i>	Designation
<i>AR</i>	Distance from mounting holes to cylinder mounting face (MS 2 — MDS 2)
<i>BR</i>	Radius of eye bracket in angle (AB7)
<i>CR</i>	Hole for bolt at trunnion bracket (AT4)
<i>DR</i>	
<i>ER</i>	Clearance radius of pivot axis (AP2 — AP4)
<i>FR</i>	
<i>GR</i>	
<i>HR</i>	
<i>JR</i>	
<i>KR</i>	
<i>LR</i>	
<i>MR</i>	Clearance radius of pivot axis (MP 1 — MP 2 — MP 3 — MP 4 — MP 7 — AB2 — AB3 — AB4)
<i>NR</i>	
<i>OR</i>	
<i>PR</i>	
<i>RR</i>	
<i>SR</i>	Clearance radius of pivot axis (AB5 — AB6)
<i>TR</i>	End view distance between mounting holes (MS 1 — MDS 1 — MS 3)
<i>UR</i>	Envelope length (MF 8 — AB4 — AB7)
<i>VR</i>	
<i>WR</i>	
<i>XR</i>	Distance between trunnion axis and opposite rod shoulder (MDT 1)
<i>YR</i>	
<i>ZR</i>	Distance between mounting face and opposite TRP (MDF 1)

Table 4 (continued)

Symbol 2nd letter <i>S</i>	Designation
<i>AS</i>	Length of the flange piston rod end (rod end dimensions)
<i>BS</i>	
<i>CS</i>	Outside diameter of stop disc at clevis bracket (AB5)
<i>DS</i>	
<i>ES</i>	Mounting length of pin (AA6-S, AA6-R)
<i>FS</i>	Distance of mounting holes (AT4)
<i>GS</i>	
<i>HS</i>	
<i>JS</i>	
<i>KS</i>	
<i>LS</i>	
<i>MS</i>	Clearance radius of pivot axis (MP 5 — MP 6)
<i>NS</i>	
<i>OS</i>	
<i>PS</i>	
<i>RS</i>	
<i>SS</i>	Longitudinal distance between mounting holes (MS 2)
<i>TS</i>	End view distance between mounting holes (MS 2 — MDS 2)
<i>US</i>	Envelope length (MS 2 — MDS 2 — MS 3)
<i>VS</i>	
<i>WS</i>	Distance from TRP to mounting face on cylinder head (Figure 9)
<i>XS</i>	Distance between TRP and front mounting holes (MS 2 — MDS 2 — MS 3)
<i>YS</i>	
<i>ZS</i>	Distance between mounting face and opposite TRP (MDF 7)

Table 4 (continued)

Symbol 2nd letter <i>T</i>	Designation
<i>AT</i>	Angle mounting thickness (MS 1 — MDS 1)
<i>BT</i>	Rib thickness (AB7)
<i>CT</i>	
<i>DT</i>	
<i>ET</i>	
<i>FT</i>	
<i>GT</i>	
<i>HT</i>	
<i>JT</i>	
<i>KT</i>	
<i>LT</i>	Clearance around pivot axis (MP 5 — MP 6)
<i>MT</i>	
<i>NT</i>	
<i>OT</i>	
<i>PT</i>	
<i>RT</i>	Size of tapped mounting holes (MX 5 — MDX 5 — MX 6 — MX 7 — MDX 7 — MX 8 — MDX 8)
<i>ST</i>	Lug height (MS 2 — MDS 2)
<i>TT</i>	
<i>UT</i>	Envelope length (MT 1 — MDT 1 — MT 2 — MT 5 — MT 6)
<i>VT</i>	
<i>WT</i>	
<i>XT</i>	Distance of mounting holes at locking plate (AL6)
<i>YT</i>	
<i>ZT</i>	

Table 4 (continued)

Symbol 2nd letter <i>U</i>	Designation
<i>AU</i>	Distance from mounting holes to cylinder mounting faces (MS 1 — MDS 1 — MS 2 — MDS 2 — MS 3)
<i>BU</i>	Width of locking plate (AL6)
<i>CU</i>	Distance between mounting bolts and pivots pin centre (AL6)
<i>DU</i>	
<i>EU</i>	Eye width (AP6)
<i>FU</i>	
<i>GU</i>	
<i>HU</i>	
<i>JU</i>	
<i>KU</i>	
<i>LU</i>	
<i>MU</i>	
<i>NU</i>	
<i>OU</i>	
<i>PU</i>	
<i>RU</i>	
<i>SU</i>	
<i>TU</i>	
<i>UU</i>	
<i>VU</i>	
<i>WU</i>	
<i>XU</i>	
<i>YU</i>	
<i>ZU</i>	Distance between mounting face and opposite TRP (MDF 5)

Table 4 (continued)

Symbol 2nd letter <i>V</i>	Designation
<i>AV</i>	Length of tapped hole (AP2 — AP4 — AP6)
<i>BV</i>	Pilot diameter (MF 7 — MDF 7)
<i>CV</i>	Centreline of axis and the top (AP2 — AP4)
<i>DV</i>	
<i>EV</i>	
<i>FV</i>	
<i>GV</i>	
<i>HV</i>	
<i>JV</i>	
<i>KV</i>	Distance across nut flats (MR 3 — MDR 3 — MR 4)
<i>LV</i>	
<i>MV</i>	
<i>NV</i>	
<i>OV</i>	
<i>PV</i>	
<i>RV</i>	
<i>SV</i>	Longitudinal distance between mounting holes (MDS 2)
<i>TV</i>	Distance between mounting holes (ME 9 — MDE 9 — ME 10)
<i>UV</i>	Envelope diameter (MT 4 — MDT 4 — MT 5 — MT 6)
<i>VV</i>	
<i>WV</i>	
<i>XV</i>	Distance between TRP and trunnion axis (MT 4 — MDT 4)
<i>YV</i>	
<i>ZV</i>	Nut flat width for pivot pin (AA4-L — AA6-L)

Table 4 (continued)

Symbol 2nd letter <i>W</i>	Designation
<i>AW</i>	
<i>BW</i>	
<i>CW</i>	Centreline of axis and the top (AP6)
<i>DW</i>	
<i>EW</i>	Eye width (MP 3 — MP 4)
<i>FW</i>	
<i>GW</i>	
<i>HW</i>	
<i>JW</i>	
<i>KW</i>	Nut thickness (MR 3 — MDR 3 — MR 4)
<i>LW</i>	
<i>MW</i>	
<i>NW</i>	
<i>OW</i>	
<i>PW</i>	
<i>RW</i>	
<i>SW</i>	
<i>TW</i>	
<i>UW</i>	End view envelope dimension (MT 4 — MDT 4 — MT 5 — MT 6)
<i>VW</i>	
<i>WW</i>	
<i>XW</i>	Distance between TRP and pivot axis (MP 7)
<i>YW</i>	
<i>ZW</i>	

Table 4 (continued)

Symbol 2nd letter	Designation
<i>X</i>	
<i>AX</i>	
<i>BX</i>	
<i>CX</i>	Diameter of pivot hole (MP 5 — MP 6)
<i>DX</i>	
<i>EX</i>	Spherical bearing width (MP 5 — MP 6)
<i>FX</i>	
<i>GX</i>	
<i>HX</i>	
<i>JX</i>	
<i>KX</i>	
<i>LX</i>	
<i>MX</i>	
<i>NX</i>	
<i>OX</i>	
<i>PX</i>	
<i>RX</i>	
<i>SX</i>	
<i>TX</i>	
<i>UX</i>	Envelope length of clevis bracket (AB3)
<i>VX</i>	
<i>WX</i>	
<i>XX</i>	
<i>YX</i>	
<i>ZX</i>	Chamfer at pivot pin (AA6-L — AA4-L)
^a TRP is defined in Clause 4.	

BSI - British Standards Institution

BSI is the independent national body responsible for preparing British Standards. It presents the UK view on standards in Europe and at the international level. It is incorporated by Royal Charter.

Revisions

British Standards are updated by amendment or revision. Users of British Standards should make sure that they possess the latest amendments or editions.

It is the constant aim of BSI to improve the quality of our products and services. We would be grateful if anyone finding an inaccuracy or ambiguity while using this British Standard would inform the Secretary of the technical committee responsible, the identity of which can be found on the inside front cover. Tel: +44 (0)20 8996 9000. Fax: +44 (0)20 8996 7400.

BSI offers members an individual updating service called PLUS which ensures that subscribers automatically receive the latest editions of standards.

Buying standards

Orders for all BSI, international and foreign standards publications should be addressed to Customer Services. Tel: +44 (0)20 8996 9001. Fax: +44 (0)20 8996 7001 Email: orders@bsigroup.com You may also buy directly using a debit/credit card from the BSI Shop on the Website <http://www.bsigroup.com/shop>

In response to orders for international standards, it is BSI policy to supply the BSI implementation of those that have been published as British Standards, unless otherwise requested.

Information on standards

BSI provides a wide range of information on national, European and international standards through its Library and its Technical Help to Exporters Service. Various BSI electronic information services are also available which give details on all its products and services. Contact Information Centre. Tel: +44 (0)20 8996 7111 Fax: +44 (0)20 8996 7048 Email: info@bsigroup.com

Subscribing members of BSI are kept up to date with standards developments and receive substantial discounts on the purchase price of standards. For details of these and other benefits contact Membership Administration. Tel: +44 (0)20 8996 7002 Fax: +44 (0)20 8996 7001 Email: membership@bsigroup.com

Information regarding online access to British Standards via British Standards Online can be found at <http://www.bsigroup.com/BSOL>

Further information about BSI is available on the BSI website at <http://www.bsigroup.com>

Copyright

Copyright subsists in all BSI publications. BSI also holds the copyright, in the UK, of the publications of the international standardization bodies. Except as permitted under the Copyright, Designs and Patents Act 1988 no extract may be reproduced, stored in a retrieval system or transmitted in any form or by any means – electronic, photocopying, recording or otherwise – without prior written permission from BSI.

This does not preclude the free use, in the course of implementing the standard, of necessary details such as symbols, and size, type or grade designations. If these details are to be used for any other purpose than implementation then the prior written permission of BSI must be obtained.

Details and advice can be obtained from the Copyright and Licensing Manager. Tel: +44 (0)20 8996 7070 Email: copyright@bsigroup.com