

Water quality — Sampling —

Part 5: Guidance on sampling of drinking water from treatment works and piped distribution systems

ICS 13.060.20; 13.060.45

National foreword

This British Standard reproduces verbatim ISO 5667-5:2006 and implements it as the UK national standard. It supersedes BS 6068-6.5:1991 which is withdrawn.

The UK participation in its preparation was entrusted by Technical Committee EH/3, Water quality, to Subcommittee EH/3/6, Sampling, which has the responsibility to:

- aid enquirers to understand the text;
- present to the responsible international/European committee any enquiries on the interpretation, or proposals for change, and keep UK interests informed;
- monitor related international and European developments and promulgate them in the UK.

A list of organizations represented on this subcommittee can be obtained on request to its secretary.

Cross-references

The British Standards which implement international publications referred to in this document may be found in the *BSI Catalogue* under the section entitled “International Standards Correspondence Index”, or by using the “Search” facility of the *BSI Electronic Catalogue* or of British Standards Online.

This publication does not purport to include all the necessary provisions of a contract. Users are responsible for its correct application.

Compliance with a British Standard does not of itself confer immunity from legal obligations.

Summary of pages

This document comprises a front cover, an inside front cover, the ISO title page, pages ii to vi, pages 1 to 17 and a back cover.

The BSI copyright notice displayed in this document indicates when the document was last issued.

Amendments issued since publication

Amd. No.	Date	Comments

This British Standard was published under the authority of the Standards Policy and Strategy Committee on 31 May 2006

© BSI 2006

INTERNATIONAL STANDARD

ISO
5667-5

Second edition
2006-04-15

Water quality — Sampling —

Part 5:

Guidance on sampling of drinking water from treatment works and piped distribution systems

Qualité de l'eau — Échantillonnage —

Partie 5: Lignes directrices pour l'échantillonnage de l'eau potable des usines de traitement et du réseau de distribution



Reference number
ISO 5667-5:2006(E)

Contents

Page

Foreword.....	iv
Introduction	vi
1 Scope	1
2 Terms and definitions.....	2
3 Design of sampling programmes	2
4 Sampling equipment.....	2
5 Sample collection locations	2
5.1 General.....	2
5.2 Service reservoirs (including water towers)	3
5.3 Water treatment plants	3
5.4 Disinfection/oxidation plants.....	3
5.5 Distribution system	3
6 Pre-collection cleaning, disinfection and flushing.....	7
6.1 General.....	7
6.2 Service reservoirs (including water towers)	7
6.3 Hydrants	8
6.4 Faucets	8
6.5 Dip sampling	9
7 On-site analysis of samples	9
8 Frequency and timing of sampling	9
9 Sample collection and handling	10
9.1 General.....	10
9.2 Volume of samples	10
9.3 Precautions to minimize contamination.....	10
9.4 Order of sampling	11
10 Sampling for particular types of analysis	12
10.1 Sampling for physical, chemical and radiological analysis	12
10.2 Sampling for microbiological analysis	12
10.3 Sampling for biological analysis.....	13
10.4 Sampling for virological analysis.....	13
11 Field measurements and continuous on-line monitoring	13
12 Sample identification and records	13
13 Sampling quality	14
13.1 General.....	14
13.2 Sampling manual	14
13.3 Training of samplers.....	15
13.4 Verification checking of the collection, handling, temporary storage and transport of samples.....	15
13.5 Independent reviews	16
Bibliography	17

Foreword

ISO (the International Organization for Standardization) is a worldwide federation of national standards bodies (ISO member bodies). The work of preparing International Standards is normally carried out through ISO technical committees. Each member body interested in a subject for which a technical committee has been established has the right to be represented on that committee. International organizations, governmental and non-governmental, in liaison with ISO, also take part in the work. ISO collaborates closely with the International Electrotechnical Commission (IEC) on all matters of electrotechnical standardization.

International Standards are drafted in accordance with the rules given in the ISO/IEC Directives, Part 2.

The main task of technical committees is to prepare International Standards. Draft International Standards adopted by the technical committees are circulated to the member bodies for voting. Publication as an International Standard requires approval by at least 75 % of the member bodies casting a vote.

Attention is drawn to the possibility that some of the elements of this document may be the subject of patent rights. ISO shall not be held responsible for identifying any or all such patent rights.

ISO 5667-5 was prepared by Technical Committee ISO/TC 147, *Water quality*, Subcommittee SC 6, *Sampling (general methods)*.

This second edition cancels and replaces the first edition (ISO 5667-5:1991), which has been technically revised.

ISO 5667 consists of the following parts, under the general title *Water quality — Sampling*:

- *Part 1: Guidance on the design of sampling programmes and sampling techniques* ¹⁾
- *Part 3: Guidance on the preservation and handling of water samples*
- *Part 4: Guidance on sampling from lakes, natural and man-made*
- *Part 5: Guidance on sampling of drinking water from treatment works and piped distribution systems*
- *Part 6: Guidance on sampling of rivers and streams*
- *Part 7: Guidance on sampling of water and steam in boiler plants*
- *Part 8: Guidance on the sampling of wet deposition*
- *Part 9: Guidance on sampling from marine waters*
- *Part 10: Guidance on sampling of waste waters*
- *Part 11: Guidance on sampling of groundwaters*
- *Part 12: Guidance on sampling of bottom sediments*
- *Part 13: Guidance on sampling of sludges from sewage and water-treatment works*

1) ISO 5667-1:1980 and ISO 5667-2:1981 are currently undergoing joint revision, which will be published as ISO 5667-1.

- *Part 14: Guidance on quality assurance of environmental water sampling and handling*
- *Part 15: Guidance on preservation and handling of sludge and sediment samples*
- *Part 16: Guidance on biotesting of samples*
- *Part 17: Guidance on sampling of suspended sediments*
- *Part 18: Guidance on sampling of groundwater at contaminated sites*
- *Part 19: Guidance on sampling of marine sediments*

The following part is under preparation:

- *Part 20: Guidance on the use of sampling data for decision making — Compliance with limits and classification*

Introduction

ISO 5667 is a group of standards dealing with the general aspects of sampling (Parts 1 to 3) and with the sampling of specific types of water (from Part 4 onwards). ISO 5667-5 covers the sampling of drinking water within a piped distribution system and should be read in conjunction with ISO 5667-1 and ISO 5667-3.

Effective monitoring of drinking water requires collaboration between sampling programme designers, water treatment plant and distribution system operators, sample collectors, laboratory analysts and data users. ISO 5667-5 gives guidance on the selection of sampling locations and the collection of samples when monitoring drinking water from treatment plants and from piped distribution systems.

Understanding of the purposes for monitoring drinking water and of the principles behind the methods of analysis is important, since specific sampling protocols can vary widely in accordance with different purposes and different analytical methods.

Examples of sampling purposes include:

- a) checking of drinking water to ensure compliance with national and/or international regulations (e.g. WHO *Guidelines for Drinking Water Quality* ^[1] and the EU Drinking Water Directive ^[2]);
- b) determination of the efficiency of a drinking water treatment plant or components thereof (for example, disinfection);
- c) quality monitoring of the water leaving the treatment plant;
- d) quality monitoring of the water within the distribution system (including distribution within large buildings);
- e) search for the cause of contamination of the distribution system (for example, in response to customer complaints);
- f) monitoring of the corrosive potential of drinking water to plumbing;
- g) assessment of the effects of materials in contact with water on the water quality (chemical and biological);
- h) monitoring of the influent water and the various processing stages in a food or beverage processing plant, including necessary treatment steps.

Water quality — Sampling —

Part 5:

Guidance on sampling of drinking water from treatment works and piped distribution systems

1 Scope

This part of ISO 5667 establishes principles to be applied to the techniques of sampling water intended for human consumption.

For the purposes of this part of ISO 5667, water intended for human consumption comprises:

- a) all water either in its original state or after treatment, intended for drinking, cooking, food preparation, or other domestic purposes, regardless of its origin, plus
- b) all water used in any production undertaking for the manufacture, processing, preservation or marketing of products or substances intended for human consumption unless the competent national authorities are satisfied that the quality of the water cannot affect the wholesomeness of the foodstuff in its finished form.

The guidance given in this part of ISO 5667 is confined to those circumstances where water is drawn from municipal or similar distribution systems (including individual systems) where prior treatment and/or quality assessment has resulted in the water being classified as suitable for drinking or potable process purposes. Specifically, this part of ISO 5667 is applicable to water that is in continuous supply relative to any stage of use up to and including the point of consumption in a distribution system. This includes distribution within large buildings in which additional water quality management might be applicable.

This part of ISO 5667 is also applicable to sampling situations that can arise relative to the investigation of system defects or emergency situations where the safety of sampling operatives is not compromised.

This part of ISO 5667 does not provide guidance for water sources or for products generated by using drinking water. The followings items are examples of cases not addressed by the present document:

- the sampling of source water, for example groundwater and surface water impoundments;
- sampling of drinking water supplies derived from non-continuous sources (for example, from road tankers);
- sampling of bulk storage of water on airplanes, trains and ships;
- the sampling of beverage products (including bottled waters) or food containing potable water used in its preparation;
- sampling of drink vending machines that dispense unsealed cups of drinks.

2 Terms and definitions

For the purposes of this document, the following terms and definitions apply.

2.1

water intended for human consumption

drinking water or potable process water

2.2

drinking water

all water either in its original state or after treatment, intended for drinking, cooking, food preparation, or other domestic purposes, regardless of its origin

2.3

potable process water

all water used in any food-production undertaking for the manufacture, processing, preservation or marketing of products or substances intended for human consumption.

3 Design of sampling programmes

Programmes for the sampling of drinking water, including statistical considerations, should be designed in accordance with ISO 5667-1.

Microbiological investigations of drinking water should be designed and implemented in accordance with ISO 19458.

4 Sampling equipment

The general recommendations for sampling equipment given in ISO 5667-1 should be followed and sample containers should be prepared in accordance with ISO 5667-3.

On-line sensors/analysing equipment for water should conform to ISO 15839.

Equipment and bottles for sampling for microbiological analysis should conform to ISO 19458.

5 Sample collection locations

5.1 General

Sample collection locations should be selected according to the following criteria.

- a) The chosen collection locations should yield samples that are representative of the system as a whole, or representative of its main components.
- b) For each treatment plant, there should be at least one sample collection location on the water intake and at least one sample collection location immediately after the processed water outlet.
- c) In systems with more than one water source, sample collection locations should reflect the output of each source, the demand on each source and the relative population using each source.
- d) Sample collection locations should be widely distributed throughout a piped distribution system, the number being proportional to the number of links or branches in the system.
- e) Sample collection locations should include locations representative of the most unfavourable sources and locations considered vulnerable to contamination such as loops, low-pressure zones and ends of systems.
- f) Where waters from different sources mix within a complex piping system, sample collection locations should permit identification of relative proportions from each source through the system.

- g) Where a distribution system connects to large buildings such as hotels or office blocks, there should be sample collection locations at the intake and throughout each building consistent with the principles in d) and e) above.

5.2 Service reservoirs (including water towers)

Samples should be collected from the inlet and outlet pipes as close as possible to the service reservoir. The outlet sample location should be upstream of the first customer.

If a service reservoir has a common inlet and outlet main, samples should, where possible, be collected when the main is acting as an outlet and the water quality is therefore representative of water that has been stored in the service reservoir. If this cannot be achieved, a sample collection pumping system should be installed and utilized.

If a service reservoir has more than one compartment but the compartments are hydraulically connected, the compartments may be regarded as a single reservoir. If a service reservoir has more than one compartment and these compartments are not hydraulically connected, each compartment should be considered as a separate service reservoir and should be assigned individual sampling points, except if the individual outlets from the compartments combine into a common outlet, in which case a single sample location on the common outlet might be adequate.

Sometimes (for example, when a reservoir has been out of service or cleaned, when there is no sampling valve on the outlet pipe, or when the surface layer of the reservoir is to be analysed), it might be necessary to take dip samples, as described in 6.5 from the service reservoirs, although this means of sampling should be avoided wherever possible. If it is essential to take dip samples, special care should be taken to ensure that the sampling operation does not introduce debris into the water and that equipment is sterilized before sampling to avoid a microbiological compromise of the water in the reservoir.

5.3 Water treatment plants

Samples should be collected from the inlet and outlet pipes as close as possible to the treatment plant. For monitoring of the different stages (for example, sedimentation and filtration) of water treatment, sampling should take place before and after the respective stage being monitored. If there is disinfection and/or an oxidation plant, sampling should be carried out as described in 5.4.

There usually is an expectation that water is better after treatment. Equipment that is inappropriate, or equipment that was poorly installed or inadequately maintained can, however, introduce contaminants and compromise microbiological quality. Additionally, some materials used to coat pipes can introduce low concentrations of contaminants such as ethylbenzene or xylenes.

5.4 Disinfection/oxidation plants

Samples from the influent to the disinfection/oxidation plant should be collected as close as possible to the point of entry to the plant. Samples of the treated water should be collected after allowing for the appropriate contact period between water and disinfectant/oxidant. In some installations, this contact period can depend upon utilization of part of the distribution systems. In these situations, samples required to test the efficiency of the disinfection/oxidation stage should be taken at an appropriate point within the distribution system. One alternative, a sample line with an appropriate residence time, may be used for sampling within the treatment plant although this is not recommended.

5.5 Distribution system

5.5.1 General

Sampling points in the distribution system should include locations representative of the typical water quality plus those locations considered vulnerable to contamination such as loops, low-pressure zones and ends of system. Where waters from different sources mix within the distribution system, sample locations should permit identification of relative proportions from each source through the system. If treatment works exist within the distribution system, sample collection points should be located before and after such works to allow assessment of the efficacy of the treatment.

Samples from the distribution system are typically collected from domestic faucets, installed sampling faucets, or fire hydrants. Where domestic faucets are utilized to characterize the water quality through a water distribution system, a computer should be used to generate a random selection of a sufficient number of locations. Domestic faucets are discussed in 5.5.2.2.

If sampling is carried out from hydrants, it should be ensured that the hydrants are suitable for drinking water sampling purposes (see 6.3).

When sampling on domestic premises, it is particularly important to ensure that equipment and chemical reagents are kept securely out of reach of children and pets. Also, flaming should be avoided if there is any fire hazard.

5.5.2 Sampling faucets

5.5.2.1 General

If a sampling faucet is to be installed or utilized specifically for sample collection:

- a) the sampling line should be as short as possible, in good condition and capable of being flushed at full flow rate;
- b) the sampling line should not protrude inside the pipe wall of the water main;
- c) the sampling line should preferably connect to the main piping immediately downstream from a valve, elbow or fitting that causes turbulent flow;
- d) water from a mains spur should not be considered to be representative of water in the main;
- e) the sampling line should be of materials suitable for the conveyance of drinking water;
- f) the sampling line should not include T-junctions, which might result in stagnation;
- g) the sampling line and faucet should be adequately protected from frost;
- h) the faucet location should be protected from vandalism and contamination;
- i) if the faucet is to be flame-disinfected, it is important that there are no flammable materials or fumes nearby;
- j) there should be adequate space to fill a variety of bottle sizes;
- k) there should be an adequate supply of water to the faucet at all times;
- l) the site should have adequate drainage, i.e., water discharged by flushing should be able to run off freely;
- m) for each fixed location, the sampler should have a location plan, details of access, and any special flushing or collection instructions.

It is recommended that a sample point chosen for frequent sampling (e.g. monitoring the working of a process in a treatment plant or food producing company) should have a faucet suitable for easy sampling for microbiological, physical and chemical analysis. An example is given in Figure 1.

Irrespective of absolute dimensions of the device illustrated in Figure 1, it is important that the neck of the receiving vessel allows adequate passage of the water into the container. In addition, there should be sufficient space between the head of the waste funnel and the faucet outlet to allow unhindered manipulation of each sample container.

When samples are collected for microbiological analysis, the sampled faucets should, where necessary, be sterilized in accordance with ISO 19458.

A need might arise to sample water where there is a very low flow. When taking the sample, care should be taken that disturbance of sedimentary material does not occur. If this cannot be avoided, a sufficient volume of water should be flushed or a sufficient time allowed for a steady state to occur after the sampling valve has been opened or the flow disturbed.

Dimensions in millimetres except where stated otherwise

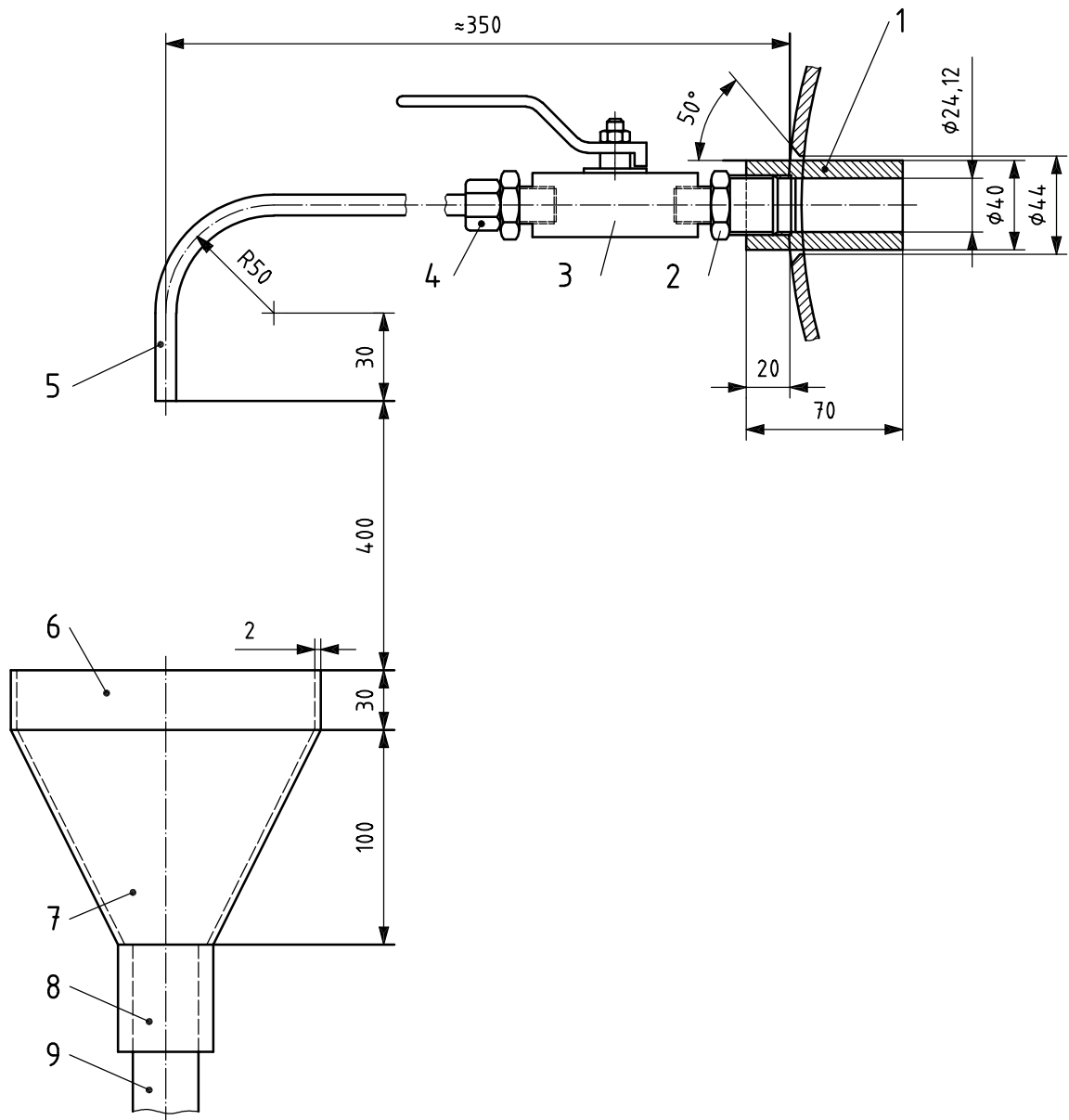

Key

- 1 pipe plug
- 2 nipple
- 3 ball valve (full flow design)
- 4 coupling ϕ 10 mm
- 5 stainless steel pipe
- 6 PVC pipe ϕ 140 mm
- 7 funnel
- 8 PVC plug ϕ 32 mm
- 9 to drain/waste

Figure 1 — Example of a faucet suitable for frequent sampling

5.5.2.2 Sampling faucets at consumers' premises

The following types of faucets should be used, where possible, when collecting drinking water samples from premises used by consumers:

- indoor faucets (as opposed to outdoor faucets);
- fixed style faucets (as opposed to swing style faucets);
- non-threaded faucets (as opposed to threaded faucets).

The following types of faucet should be avoided when taking samples:

- a) faucets connected to or adjacent to treatment devices such as pressure tanks, pumps and softeners;
- b) faucets with threaded attachments connected that can be removed;
- c) faucets of a style difficult to disinfect;
- d) faucets in poor repair;
- e) faucets dirty with grease or other substances;
- f) faucets in restroom facilities;
- g) faucets in restaurant dishwashing areas or similar cleaning areas;
- h) faucets in areas used to store or handle petrochemicals, industrial chemicals or pesticides;
- i) hot water faucets or mixed hot and cold supplies (unless *Legionella* species are to be analysed);
- j) faucets where the sample containers cannot conveniently fit under the faucet.

Where a randomly selected property is not accessible, not safe or lacks an appropriate faucet, it is acceptable to sample from a neighbouring property. Repeated sampling in case of suspected hygienic problems should always be from the same sample point.

When samples are collected for microbiological analysis, the sampled faucets should, where necessary, be sterilized in accordance with ISO 19458.

5.5.3 Distribution systems within large buildings

Plumbing systems within large buildings can be very complicated. Sources of contamination that are commonly found include incorrectly installed water fittings and systems, poorly maintained storage facilities, localized heating, back-flow, cross-contamination, flow impediments and permeation through unsuitable material. Complexes of large buildings, such as hospitals, often consist of a variety of buildings of different ages and with pipe-work of different materials. Often there are long and complicated pipe-runs and sometimes "dead-legs". Consult as-built drawings, if available, for guidance in this respect.

Water collection sample locations should be based upon knowledge of the distribution system and upon water use within the building. The primary sampling location(s) for microbiological examination should be from a rising main.

NOTE There are circumstances in some jurisdictions when microbiological monitoring is required for the control of organisms such as *Legionella*. Attention is drawn to local health and safety regulations covering the monitoring and sampling of such species.

Sampling locations may also include the following:

- a) both inlet and outlet to storage tanks where the water is used for drinking, food preparation or bathing purposes;
- b) large storage tanks (these might require additional dip sampling from possible stagnant areas);
- c) both inlet and outlet to water treatment equipment such as water softeners, where the water is used for drinking or food preparation purposes;
- d) both inlet and outlet to any specialized water treatment equipment utilized where the water is used in the preparation or manufacture of food or beverages;
- e) representative points relative to the pipe-work distribution system, for example, beginning, middle and end of distribution branches;
- f) sites to check maintenance of disinfection residuals where potable service break tanks are maintained in tall buildings;
- g) points within vulnerable locations such as dead-end mains;
- h) supplies to kitchens and to equipment such as ice-making machines or drink vending machines;
- i) hot water supplies.

On rare occasions, it might be necessary to collect samples from storage reservoirs by dip sampling, although this is strongly discouraged and should only be carried out where the integrity of the water supply can be maintained by thorough cleaning and disinfection of the sampling equipment.

6 Pre-collection cleaning, disinfection and flushing

6.1 General

Cleaning, disinfection and flushing prior to sample collection depend on specific objectives of the monitoring program. In general, sampling to ascertain the quality of the water delivered to a building, or to ascertain whether the quality of water delivered within a building is possibly altered by the service network within the building, should not be carried out without thorough cleaning and flushing of the sampling points. Investigation of water quality as delivered from a faucet might require that samples be collected before cleaning and flushing, or samples might be required both before and after cleaning and flushing.

Some systems are flushed out on an annual basis. Where annual flushing is known to occur, sampling before and after such flushing can yield useful information.

Record detailed information regarding cleaning, disinfection and flushing. Site reports should include mention of any device at the sampling point which might have a negative effect on the representativity of collected samples, or which impede disinfection.

6.2 Service reservoirs (including water towers)

Generally, 2 min or 3 min of free flow should be allowed to flush out any stale water within the sampling line before taking a sample. If this is insufficient, calculate the volume of water that needs to be displaced from the pipe, estimate the flushing time required at an appropriate flushing rate and then apply a flushing time of five times that value. Alternatively, when the reservoir is below ground, monitoring of the water temperature from the flushing can be useful in indicating when water from the reservoir is being withdrawn from the main body.

6.3 Hydrants

Samples should be taken from a suitable sampling faucet whenever possible. However, in some circumstances it may be necessary to take samples from hydrants. If samples are to be collected from a hydrant, all surfaces should be thoroughly cleaned and free of debris on each visit. If microbiological samples are to be collected, special disinfection precautions are required. The procedure for preparing hydrants for microbiological sampling is given in ISO 19458.

6.4 Faucets

6.4.1 General

Depending on the objectives of the monitoring programme, it should be decided whether samples are required from faucets as they are found, whether samples should be collected after cleaning, disinfecting and flushing of the faucets, or whether samples are required before and after such cleaning, disinfection and flushing. Whether or not faucets are cleaned, disinfected or flushed prior to sample collection depends on the sampling purpose. If the effects of materials on water quality are being investigated, then the initial draw-off should be sampled. Samples may also be taken after a specified period of stagnation to provide information on the rate at which materials affect water quality or the maximum likely effect. If the quality of the water as supplied to premises is to be checked, then the faucets should be cleaned and flushed at a uniform rate for 2 min to 3 min or longer if necessary to achieve constant temperature before samples are collected. The faucets should be cleaned, disinfected and flushed if samples are to be collected for microbiological analysis. Faucets should be left flowing at a steady rate during sampling.

The detailed requirements for cleaning, disinfecting and flushing faucets for microbiological sampling are given in ISO 19458.

For non-microbiological sampling, all fittings should be removed and faucets cleaned then flushed for 2 min to 3 min (to constant temperature) before samples are collected. Cleaning may be done using, for example, a 2-propanol wipe or a small brush. Prior to sampling, the faucet should be turned on and left to run at a uniform rate for some period of time in order to flush standing water from the service pipes (2 min to 3 min is usually sufficient). Sometimes it might be necessary to allow the water to flow freely for as long as 30 min before collecting the sample, for example, when sampling a mains spur in which there might be settled sediment that needs flushing out before sampling. Faucets should be left on at a steady flow while samples are collected.

It is essential to remove aerators within the faucet, as these are frequently made of plastic or rubber and may contain material that cannot be disinfected, may degrade on disinfection, or may contaminate samples.

NOTE 1 Attention is drawn to the requirements of local and national regulations regarding the cleaning, disinfection and flushing of faucets prior to sample collection.

NOTE 2 Where requirements of ISO 19458 and ISO 5667-5 are not compatible, separate sampling occasions can be required for the collection of microbiological and non-microbiological samples.

When investigating local distribution within a building, samples should be collected with and without faucet attachments and with and without flushing. In such cases, the sequence of sampling should be as follows:

- a) collect a sample without removing attachments and without flushing;
- b) without removing the attachments, flush for 2 min to 3 min and collect;
- c) remove attachments, clean, disinfect if appropriate and flush for 2 min to 3 min, then collect;
- d) with attachments removed, turn off for 30 min, then collect;

NOTE 3 Some countries or areas also specify that an additional sample be collected with the attachments detached, e.g. after an overnight stagnation period or after a stagnation period of 4 h.

- e) replace attachments.

6.4.2 Continuous flowing faucets

The case of continuous flowing faucets (with no possibilities to stop or to modify the water flow) is not described in this text. Such continuous flowing faucets require special procedures for cleaning and disinfection.

Continuous flowing faucets are very often used in controlling water treatment plants or service reservoirs because the continuous flow largely reduces possible sources of contaminations (microbiological or chemical).

6.5 Dip sampling

Dip samples should only be collected where there is no appropriate alternative. Commercially available sterilised single-use dip samplers that are mounted on short rod handles may be used to sample small tanks. For larger reservoirs, sterile dip apparatus and sample bottles may be attached to a chain or rope of sufficient length. The chain or rope can be attached directly or via a bottle cage. Extreme care should be taken to avoid contamination. Sample bottles, apparatus, bottle cages, bottle lids and chains should preferably all be autoclaved, packaged in suitable material and the wrapping removed immediately prior to use.

The detailed requirements for microbiological investigations are given in ISO 19458.

7 On-site analysis of samples

Before collection of samples, it should be decided whether some of the analyses are to be performed on-site. On-site analysis should be carried out for water temperature, ambient air temperature and also for visual inspection of the sample. Furthermore, on-site analysis should be carried out for such determinands as odour, taste, pH, chlorine, ozone, dissolved oxygen, base capacity, carbon dioxide and specific (electrical) conductivity. These parameters may also be determined in the laboratory only if it can be shown that the results are statistically identical.

The above list of determinands is not exhaustive. All determinands found not to be stable need to be measured on site.

8 Frequency and timing of sampling

For detailed guidance on frequency and timing of sampling, including statistical considerations, reference should be made to ISO 5667-1. The minimum frequencies for different parameters need not be the same. The sampling frequency depends, among other factors, on:

- a) the purpose for which sampling is being performed;
- b) the number of consumers served;
- c) the volume of water distributed;
- d) the specific residence time or turnover rate = daily volume distributed/ total system volume;
- e) the quality of the raw water;
- f) the variability of the raw water quality;
- g) the parameters that require monitoring;
- h) the complexity and characteristics of the specific distribution system being sampled;
- i) specific chemical and biological parameters.

9 Sample collection and handling

9.1 General

Sampling locations, national regulations and local safety regulations all might influence the methods of sample collection employed.

Reference should be made to ISO 5667-1 for guidance regarding sampling techniques, to ISO 5667-3 for guidance regarding the preservation and handling of samples and to ISO 19458 for guidance regarding collection of samples for microbiological investigations. When sampling for emergency purposes, specific guidance should be sought from the analysing laboratory or other scientific expert to ensure meaningful samples are obtained.

Since different analytical methods can require different methods of preservation, distribution of the sample into several containers might be necessary. To minimize changes in the samples during collection, storage and transport, these operations should be carried out in as short a time period and as soon after sampling as possible.

If avoidance of sample contact with air is necessary, the sample container should be filled to overflowing, allowing at least two volumes to overflow and then immediately stoppered and checked to ensure the absence of air bubbles

If filtration is necessary on site, for example, to separate two forms of a determinant, the sample should be filtered during or immediately after collection so as to minimize any changes that might occur in the sample. Scientific testing and evaluation is recommended to ascertain appropriate filtering technique and permissible delay before filtration.

Additionally each sample bottle should be labelled, registered on an appropriate form, carefully packed to avoid breakage during shipping and delivered to the analysing laboratory within the prescribed timeframe. Before transporting the sample to the laboratory, the appropriate preservation technique should be applied; reference should be made to the guidance given in ISO 5667-3.

For general recommendations and for cautions and guidance regarding preservation and holding time, reference should be made to ISO 5667-3. Some parameters including residual chlorine, pH and turbidity should be tested immediately after sampling as they are likely to change during transport and storage.

9.2 Volume of samples

The volume of the samples to be collected depends on the number and types of analyses to be performed. Reference should be made to the relevant international Standards for the analytical methods for the volumes needed for each determination.

If very small concentrations are to be determined, the volume of the samples might have to be large. The taking of large volume samples can mask variations in the water quality during the sampling period but the sample volume might be an overriding factor in the requirements of the analysis.

Composite samples should generally not be taken for the analysis of drinking water except for special studies. Large composite samples can be used when sampling for certain pathogens, for example, *Giardia lamblia*.

9.3 Precautions to minimize contamination

The following precautions should be taken during sample collection and handling to minimize contamination of samples:

- a) thoroughly wash hands and/or wear disposable gloves;
- b) never smoke while taking samples and always avoid breathing on the samples;

- c) do not eat or drink while taking samples;
- d) only use laboratory-provided sample bottles and containers;
- e) only use laboratory-supplied reagents;
- f) where reagents are used for preservation, sequence the order of sample collection to minimize the chance of cross-contamination of samples by reagents;
- g) do not use reagents that have passed an expiry date or that have an abnormal colour;
- h) avoid contamination of the outside of sample containers;
- i) remove the cap from a sample bottle immediately before sample collection and place the top in a clean/sterile bag or container while the sample is being collected;
- j) never insert any foreign object (such as a thermometer or pH probe) into a bottle intended for other analyses;
- k) avoid use of sample splitters unless specifically required;
- l) never use metal sampling devices if the analysis is to detect trace metals;
- m) prior to use, ensure that sample bottles are stored in clean areas and are capped and/or wrapped;
- n) ensure that all sample bottles or containers are closed hand-tight after sampling;
- o) if possible, pre-cool samples and keep them dark before shipping, especially in summer months.

9.4 Order of sampling

The order in which samples are collected should be based on the purpose of the sampling and the potential for cross contamination or other adverse effects on sampling. For example, use of hypochlorite solution to disinfect faucets may adversely affect samples taken subsequently for trihalomethanes, chlorinated organics, residual chlorine, polycyclic aromatic hydrocarbons and any other determinand which may be produced, destroyed or changed by oxidation to a form which will not be determined. Total organic carbon may be adversely affected by the use of an isopropanol wipe, and it has been suggested that flaming a faucet may in some circumstances produce polycyclic aromatic hydrocarbons. Details of the requirements for different types of microbiological samples are given in ISO 19458.

Some combinations of sampling requirements may be incompatible and require separate sampling occasions. When separate sampling occasions is not an option, alternative strategies for obtaining the same information should be considered and decisions made on which samples to take based on an assessment of priorities.

For routine sampling for checking the quality of water as supplied, or at a specific point within the treatment and distribution systems, the following order of sampling is suggested:

- a) first draw samples;
- b) flush (if total organic carbon sample required);
- c) take total organic carbon samples;
- d) turn off the faucet;
- e) clean the faucet;
- f) flush;

- g) take all other samples for physico-chemical parameters (including field determinations) in an order designed to minimize cross contamination of samples by reagents;
- h) turn off the faucet;
- i) disinfect the faucet (see ISO 19458);
- j) flush the faucet (see ISO 19458);
- k) take samples for microbiological parameters (see ISO 19458).

After the initial flush for 2 min to 3 min or to constant temperature, subsequent flushes should be sufficient to remove any residual cleaning or disinfecting agent and re-establish a steady flow. If hypochlorite solution is used for disinfection, it is suggested that free chlorine levels are checked before samples are taken.

A different order of sampling may be required for other purposes, when special precautions may be needed to prevent contamination of samples.

10 Sampling for particular types of analysis

10.1 Sampling for physical, chemical and radiological analysis

Reference should be made to ISO 5667-1 for guidance regarding sampling techniques and to ISO 5667-3 for guidance regarding the preservation and handling of samples.

If contact with air is to be avoided and the samples are not intended for preservation, the sample container should be slowly filled to overflowing, allowing at least two volumes to overflow, and then stoppered tightly and checked to ensure the absence of air bubbles.

Samples that are to be preserved should not be filled to overflowing.

For the determination of oxygen or dissolved gases, it is necessary to use a hose, attached to the faucet or pump outlet, that reaches the bottom of the sample container. The water should be allowed to flow slowly into the sampling container through the hose.

If sampling for particulate matter, special care should be taken to obtain representative samples:

- a) at a location where particulate matter is uniformly distributed in the pipe, by sampling from a straight length of pipe as far as practicable from any bends or valves that might introduce turbulence;
- b) from the bulk fluid by, for example, sampling isokinetically via a sampling probe protruding into the pipe and facing into the direction of flow;
- c) by transporting the sample to the point of collection without producing changes, for example, by avoiding long horizontal sections of the sampling line and using small bore pipe-work for the sampling line, to ensure turbulent conditions within the sampling line.

Once collected, samples and filters should be visually examined for unusual characteristics such as sediments or colour. The sampling method details, visual observations and also information concerning any non-standard events or methods all should be documented on the sampling report.

In the case of sampling and transporting samples for analysis of organic micro-components, beware of contamination of gasses from fuel and paint.

10.2 Sampling for microbiological analysis

Guidance on the requirements for microbiological analysis is given in ISO 5667-1 and ISO 19458.

10.3 Sampling for biological analysis

Macro-invertebrate animals and their associated detritus in distribution systems may be sampled directly or by flushing known volumes of water from the system through nets.

Flushing should be carried out using flows of sufficient velocity to release debris. A polyamide net, of mesh aperture about 150 µm, should be used to collect the sample. The net should be connected to the water outlet via a flow gauge. Efficiency of flushing can be increased by using a foam swab followed by flushing to release the animals.

To investigate biotic infestation of distribution systems, similar techniques and equipment should be employed but at or near possible points of ingress. Stainless steel filters of mesh aperture typically 0,5 mm may be used in conjunction with flow meters and/or pumps.

Core samplers should be used for sampling filter beds. Insects, as potential contaminants, can be sampled in enclosed systems using commercially available UV-electric attractor traps. Direct observation at obvious locations should always be carried out.

Samples for biological analysis should be preserved in accordance with ISO 5667-3.

10.4 Sampling for virological analysis

The collection of samples of water for the detection of viruses is similar in many respects to collecting for microbiological analysis. The main difference is in the large volume of the sample required for virological analyses. Reference should be made to ISO 5667-1 for large volume sampling.

NOTE It can be more convenient to concentrate samples rather than to transfer large volumes of water to the laboratory. Nonetheless, methods for concentrating viruses from water are still being researched and continue to be modified and improved. The efficiency of a virus concentration method can vary widely depending on the quality of the water.

11 Field measurements and continuous on-line monitoring

Field measurements and continuous on-line monitoring yield results rapidly and also tend to be somewhat less expensive than laboratory analyses, although operating personnel require appropriate training in laboratory techniques if the results are to be relied upon.

Reference should be made to ISO 13530 regarding analytical quality control for water analysis, and to ISO 15839 regarding on-line sensors/analysing equipment for water.

Thermometers and thermistors should be verified against a reference thermometer at least once per year. Many chemical instruments and sensors require very intensive and frequent calibration, as specified by the manufacturer's recommendations or national regulations. Some instruments may require daily calibration.

12 Sample identification and records

Immediately after the collection of each sample, the sample container should be labelled so that the sample is easily identifiable.

A report should be prepared for each sampling location. The location should be described in detail, with a statement as to field measurement results, weather conditions, unusual events or unusual appearance of the site or samples. When sampling for specific reasons (e.g. in response to a complaint), detailed information should be included. It is important that the time of collection for each sample is recorded. If the same sampling location is used repeatedly, it is not necessary to repeat all details every time. In this case, only a statement of the on-site measurements, time of sample collection, and information regarding weather conditions, unusual events and similar observations need be recorded. The sampler should be identified on the report, preferably by name and signature. In some circumstances, photographs and detailed written records are invaluable when it comes to interpreting monitoring data.

13 Sampling quality

13.1 General

A programme to establish sampling quality should be established for every series of sampling, so as to ensure that data resulting from sampling programs both are trustworthy and are scientifically credible. Mistakes in any step of the sampling procedure can result in substantial errors within the resulting data.

Laboratories that analyse collected samples usually have rigorous programmes of quality assurance and quality control (QA/QC) as required by national regulation and complying with ISO 17025. However, such laboratory programmes of QA/QC cannot substitute for the rigorous sampling quality programmes required for the collection and handling of samples prior to delivery to laboratories for analysis.

Sampling quality programmes comprise all the steps taken to assure that valid results are produced. Sampling quality programmes include documented evidence that the individuals who collect samples are competent and well trained, that appropriate sample collection and sample handling methods were employed, that equipment were maintained and calibrated, that correct practices were followed and that records are both complete and secure. Sampling quality programmes should include use of blank samples (samples of purified water handled as if genuine samples) to assess contamination of samples and use of appropriate replicate samples to assess precision and repeatability.

Particular importance should be given to careful measurement of analyses performed on-site and to correct recording of determinand results. Reference should be made to ISO 13530 regarding analytical quality control for water analysis, to ISO 5667-14 regarding quality assurance of water sampling and handling and to ISO 15839 regarding on-line sensors/analysing equipment for water.

Since analysing laboratories have expertise regarding QA/QC, it is suggested they be actively involved in design and evaluation of sampling quality programmes.

13.2 Sampling manual

Each person responsible for collecting drinking water samples should carry an up-to-date sampling manual. This manual should provide specific guidance regarding sampling methods to be employed, sample handling and preservation, analytical methods for measurements to be performed at the sampling site, procedures to be followed when transporting samples to the laboratory and method details pertaining to any on-line continuous sensor type equipment to be utilized. It is suggested that the sampling manual should additionally detail all sampling quality procedures to be employed when collecting samples, when taking on-site measurements, when transporting samples to laboratory and when using or checking continuous monitoring equipment.

The sampling manual should specify:

- a) the types of bottles or containers, their closures and the specific purposes for which they are to be used;
- b) where relevant, the cleaning procedure and shelf life for bottles, containers and closures used for each parameter, including the amount and type of preservative to be added;
- c) the sampling procedure for each parameter, including the type of sample to be collected (e.g. first draw, flushed, stagnation) and the procedure for collecting samples for different parameters;
- d) the frequency and order of sampling;
- e) the conditions of storage and transport of samples and the maximum time that can elapse before analysis should commence for each parameter;
- f) description of preservation reagents (including usual colour), plus appropriate safety measures in case of spill, or contact with skin or eyes.

It is recommended that the manual should additionally provide guidance as to appropriate sampling responses when unusual conditions are identified, plus a contingency plan for emergency conditions.

NOTE If laptop computers are used in the field, then electronic versions of manuals are convenient. Electronic templates and spreadsheets may be useful both by reducing errors in recording information and by providing automatic calculations.

13.3 Training of samplers

All samplers should be fully trained before being allowed to work unsupervised. Training should include:

- a) principles and practices of water supply distribution;
- b) principles and practices of water supply hygiene;
- c) introductory knowledge of water chemistry and of microbiology;
- d) knowledge of water supply vulnerabilities to contamination including case studies of genuine contamination events with emphasis upon faecal contamination;
- e) experience in all aspects of sampling;
- f) supervised experience with laboratory techniques if the sampler is expected to take analytical measurements or to operate on-line monitoring equipment;
- g) review of this part of ISO 5667 plus review of relevant clauses of reference standards;
- h) the full content of the sampling manual with special emphasis on identifying, and safely coping with or avoiding potential hazards.

Once trained, all samplers' performance should be subject to regular review. Monitoring and review procedures, criteria for satisfactory performance and policy on retraining should be documented. This training should be updated on a regular basis. More detailed information about requirements for training of personnel is given in ISO 17025.

A training record should be produced for each sampler detailing the training given, with dates and assessment of competence, results of evaluation reviews, retraining or further training given and any re-assessment of competence. An annual review of such training is considered the minimum.

13.4 Verification checking of the collection, handling, temporary storage and transport of samples

As part of the continuing monitoring to verify the quality of sampling (including sample collection, sample handling, temporary storage of samples and transport of samples to laboratory), a system of routine checks should be implemented to demonstrate satisfactory control of the sampling quality. While primary control of quality is through the quality assurance system, further quantitative checks are needed to demonstrate satisfactory performance.

The sampling quality procedures described below are intended to supplement the normal procedures and checks carried out to maintain quality such as visual checks of sample bottles, reagents and collected samples. When a problem is identified, further checks should be carried out to identify the precise cause of the poor performance and remedial actions taken. Similarly, checks should be carried out to demonstrate the suitability of new sampling arrangements before they are implemented. Guidance is given on suitable routine quality control procedures in ISO 5667-14 including more detailed checks that can be used to either establish the suitability of sampling, sample preservation and sample storage arrangements or to investigate problems identified by the routine checks. The level of the sampling quality system should preferably be in accordance with ISO 17025.

13.5 Independent reviews

It is recommended that sampling quality programmes should include regular reviews of the sampling process by an experienced scientist independent of the agency responsible for implementing such programmes.

The reviews should include the following evaluations.

- a) Do the sampling personnel have clearly defined responsibilities, appropriate qualifications, appropriate training and adequate supervision?
- b) Are sample collection locations appropriately chosen and prepared?
- c) Are there any safety concerns? Do sampling personnel have the experience and training to handle these types of safety issues?
- d) Is the sampling and monitoring equipment regularly serviced, maintained and calibrated?
- e) Are all reagents clearly labelled and not past expiry date? Do samplers wear necessary safety clothing, glasses and equipment? Do samplers dispose of old reagents and used material safely and appropriately?
- f) Can sampling personnel recognize degraded reagents or unusual samples?
- g) Does each sampler have an up-to-date sampling manual and follow the specified methods? Have all methods been documented and verified?
- h) Are samples correctly labelled, handled, preserved and transported to laboratory appropriately and within target limits?
- i) Are sample collection records completed and do they unambiguously identify sample location, sample time and sampler? Also do they include analytical methods and associated quality control and quality assurance for measurements made on site?
- j) If samplers are responsible for servicing on-line monitoring equipment, are the necessary maintenance and quality verification documents regularly updated?
- k) Are the sample collection records and data safely archived and readily retrievable?

Bibliography

- [1] *Guidelines for drinking-water quality*, second edition, Volume 3, *Surveillance and control of community supplies*. World Health Organization, Geneva, 1997
- [2] Council Directive 98/83/EC of 3 Nov. 1998 on the quality of water intended for human consumption. ("European Drinking Water Directive"). Official Journal of the European Communities, 5 Dec. 1998, L330/32
- [3] *Standard Methods for the Examination of Water and Wastewater*, 20th edition. A. Greenberg et al. (eds.), APHA, AQQA, WEF, Jan. 1, 1999; ISBN: 0875532357
- [4] *Quality Assurance in Environmental Analysis*. M.J.R Clark. In: *Encyclopedia of Analytical Chemistry*, R.A. Meyers (ed.), John Wiley & Sons Ltd., Chichester, UK, 2000
- [5] *Environmental Sampling and Analysis: A Practical Guide*. L.H. Keith, CRC Press, Boca Raton, Florida, USA, 1991
- [6] *Field Guide to Potable Water Sampling*. G. Tarbutt (ed.) Yorkshire Water Services, Yorkshire, UK, 2001
- [7] *The Microbiology of Drinking Water (2002) — Part 1 — Water Quality and Public Health*. Standing Committee of Analysts, Environmental Agency, UK, 2002
- [8] *The Microbiology of Drinking Water (2002) — Part 2 — Practices and Procedures for Sampling*. Standing Committee of Analysts, Environmental Agency, UK, 2002
- [9] ISO 5667-1²⁾, *Water quality — Sampling — Part 1: Guidance on the design of sampling programmes and sampling techniques*
- [10] ISO 5667-3, *Water quality — Sampling — Part 3: Guidance on the preservation and handling of water samples*
- [11] ISO 5667-14, *Water quality — Sampling — Part 14: Guidance on quality assurance of environmental water sampling and handling*
- [12] ISO/TR 13530, *Water quality — Guide to analytical quality control for water analysis*
- [13] ISO 15839, *Water quality — On-line sensors/analysing equipment for water — Specifications and performance tests*
- [14] ISO/IEC 17025, *General requirements for the competence of testing and calibration laboratories*
- [15] ISO 19458³⁾, *Water quality — Sampling for microbiological analysis*
- [16] ISO 8199, *Water quality — General guidance on the enumeration of micro-organisms by culture*

2) To be published. (Revision of ISO 5667-1:1980 and ISO 5667-2:1991)

3) To be published.

BSI — British Standards Institution

BSI is the independent national body responsible for preparing British Standards. It presents the UK view on standards in Europe and at the international level. It is incorporated by Royal Charter.

Revisions

British Standards are updated by amendment or revision. Users of British Standards should make sure that they possess the latest amendments or editions.

It is the constant aim of BSI to improve the quality of our products and services. We would be grateful if anyone finding an inaccuracy or ambiguity while using this British Standard would inform the Secretary of the technical committee responsible, the identity of which can be found on the inside front cover.
Tel: +44 (0)20 8996 9000. Fax: +44 (0)20 8996 7400.

BSI offers members an individual updating service called PLUS which ensures that subscribers automatically receive the latest editions of standards.

Buying standards

Orders for all BSI, international and foreign standards publications should be addressed to Customer Services. Tel: +44 (0)20 8996 9001.
Fax: +44 (0)20 8996 7001. Email: orders@bsi-global.com. Standards are also available from the BSI website at <http://www.bsi-global.com>.

In response to orders for international standards, it is BSI policy to supply the BSI implementation of those that have been published as British Standards, unless otherwise requested.

Information on standards

BSI provides a wide range of information on national, European and international standards through its Library and its Technical Help to Exporters Service. Various BSI electronic information services are also available which give details on all its products and services. Contact the Information Centre.
Tel: +44 (0)20 8996 7111. Fax: +44 (0)20 8996 7048. Email: info@bsi-global.com.

Subscribing members of BSI are kept up to date with standards developments and receive substantial discounts on the purchase price of standards. For details of these and other benefits contact Membership Administration.
Tel: +44 (0)20 8996 7002. Fax: +44 (0)20 8996 7001.
Email: membership@bsi-global.com.

Information regarding online access to British Standards via British Standards Online can be found at <http://www.bsi-global.com/bsonline>.

Further information about BSI is available on the BSI website at <http://www.bsi-global.com>.

Copyright

Copyright subsists in all BSI publications. BSI also holds the copyright, in the UK, of the publications of the international standardization bodies. Except as permitted under the Copyright, Designs and Patents Act 1988 no extract may be reproduced, stored in a retrieval system or transmitted in any form or by any means – electronic, photocopying, recording or otherwise – without prior written permission from BSI.

This does not preclude the free use, in the course of implementing the standard, of necessary details such as symbols, and size, type or grade designations. If these details are to be used for any other purpose than implementation then the prior written permission of BSI must be obtained.

Details and advice can be obtained from the Copyright & Licensing Manager.
Tel: +44 (0)20 8996 7070. Fax: +44 (0)20 8996 7553.
Email: copyright@bsi-global.com.