

BS ISO 5488:2015



BSI Standards Publication

Ships and marine technology — Accommodation ladders

bsi.

...making excellence a habit.™

National foreword

This British Standard is the UK implementation of ISO 5488:2015. It supersedes BS MA 89:1980 which is withdrawn.

The UK participation in its preparation was entrusted to Technical Committee SME/32, Ships and marine technology - Steering committee.

A list of organizations represented on this committee can be obtained on request to its secretary.

This publication does not purport to include all the necessary provisions of a contract. Users are responsible for its correct application.

© The British Standards Institution 2015.
Published by BSI Standards Limited 2015

ISBN 978 0 580 87174 0

ICS 47.020.50

Compliance with a British Standard cannot confer immunity from legal obligations.

This British Standard was published under the authority of the Standards Policy and Strategy Committee on 31 December 2015.

Amendments/corrigenda issued since publication

Date	Text affected
------	---------------

INTERNATIONAL
STANDARD

BS ISO 5488:2015

ISO
5488

Second edition
2015-12-15

**Ships and marine technology —
Accommodation ladders**

Navires et technologie maritime — Échelles de coupée



Reference number
ISO 5488:2015(E)

© ISO 2015



COPYRIGHT PROTECTED DOCUMENT

© ISO 2015, Published in Switzerland

All rights reserved. Unless otherwise specified, no part of this publication may be reproduced or utilized otherwise in any form or by any means, electronic or mechanical, including photocopying, or posting on the internet or an intranet, without prior written permission. Permission can be requested from either ISO at the address below or ISO's member body in the country of the requester.

ISO copyright office
Ch. de Blandonnet 8 • CP 401
CH-1214 Vernier, Geneva, Switzerland
Tel. +41 22 749 01 11
Fax +41 22 749 09 47
copyright@iso.org
www.iso.org

Contents

Page

Foreword	iv
1 Scope	1
2 Normative references	1
3 Types	1
3.1 Revolving-platform ladder.....	1
3.2 Fixed-platform ladder.....	1
4 Definitions	2
4.1 Nominal length, L_1	2
4.2 Design length, L_2	3
4.3 Width, b	3
4.4 Handrail height, a	3
5 Dimensions	4
5.1 Nominal length, L_1	4
5.2 Width, b	4
5.3 Distance between steps.....	4
5.4 Handrail height, a	4
5.5 Distance between stanchions.....	4
6 Manufacture	4
6.1 Design.....	4
6.1.1 Minimum angle of use.....	4
6.1.2 Maximum angle of use.....	4
6.1.3 Design loading.....	5
6.1.4 Step design.....	5
6.1.5 Design loading for access and intermediate platforms.....	5
6.1.6 Design loading for handrail.....	5
6.1.7 Support points.....	5
6.1.8 Strength and design of the ladder frame.....	5
6.1.9 Safety factor.....	5
6.2 Materials.....	5
6.3 Surface requirements.....	6
7 Quality or manufacture	6
8 Testing	6
8.1 Procedure.....	6
8.2 Measure.....	6
9 Inspection	7
10 Marking	7
Bibliography	8

Foreword

ISO (the International Organization for Standardization) is a worldwide federation of national standards bodies (ISO member bodies). The work of preparing International Standards is normally carried out through ISO technical committees. Each member body interested in a subject for which a technical committee has been established has the right to be represented on that committee. International organizations, governmental and non-governmental, in liaison with ISO, also take part in the work. ISO collaborates closely with the International Electrotechnical Commission (IEC) on all matters of electrotechnical standardization.

The procedures used to develop this document and those intended for its further maintenance are described in the ISO/IEC Directives, Part 1. In particular the different approval criteria needed for the different types of ISO documents should be noted. This document was drafted in accordance with the editorial rules of the ISO/IEC Directives, Part 2 (see www.iso.org/directives).

Attention is drawn to the possibility that some of the elements of this document may be the subject of patent rights. ISO shall not be held responsible for identifying any or all such patent rights. Details of any patent rights identified during the development of the document will be in the Introduction and/or on the ISO list of patent declarations received (see www.iso.org/patents).

Any trade name used in this document is information given for the convenience of users and does not constitute an endorsement.

For an explanation on the meaning of ISO specific terms and expressions related to conformity assessment, as well as information about ISO's adherence to the WTO principles in the Technical Barriers to Trade (TBT) see the following URL: [Foreword - Supplementary information](#)

The committee responsible for this document is ISO/TC 8, *Ships and marine technology*, Subcommittee SC 1, *Lifesaving and fire protection*.

This second edition cancels and replaces the first edition (ISO 5488:1979), which has been technically revised.

Ships and marine technology — Accommodation ladders

1 Scope

This International Standard specifies requirements and the method of test for accommodation ladders used on merchant ships (excluding passenger ships) to enable crew and pilots to embark and disembark safely.

This International Standard is applicable to the design, manufacturing and testing of accommodation ladders as well as accommodation ladder used specifically in combination with pilot ladder (hereinafter referred as “pilot accommodation ladder”).

2 Normative references

The following documents, in whole or in part, are normatively referenced in this document and are indispensable for its application. For dated references, only the edition cited applies. For undated references, the latest edition of the referenced document (including any amendments) applies.

ISO 209:2007, *Aluminium and aluminium alloys — Chemical composition*

ISO 630-1, *Structural steels — Part 1: General technical delivery conditions for hot-rolled products*

ISO 2408, *Steel wire ropes for general purposes — Minimum requirements*

IMO Resolution A.1045(27), *Pilot transfer arrangements*

3 Types

3.1 Revolving-platform ladder

The ladder, of single-flight, multi-flight or telescopic construction, is hinged from an upper revolving platform and is capable of being varied in direction and inclination between the ship and the lower access level.

The ladder may be supported by steel wire ropes or chains from the lower suspension point or by rollers fixed to the bottom of the ladder (see [Figure 1](#), [Figure 2](#) and [Figure 3](#)).

3.2 Fixed-platform ladder

The ladder is hinged from a fixed anchorage and is capable of being varied in inclination between the ship and the lower access level.

This ladder is supported by steel wire ropes or chains from suspension point(s) in the lower part of the ladder (see [Figure 1](#), [Figure 2](#) and [Figure 3](#)). This ladder may be of single-flight or telescopic construction.

This ladder is mainly applicable to pilot accommodation ladders.

4 Definitions

4.1 Nominal length, L_1

4.1.1 For a single-flight ladder, the distance from the centre of the top pin to the centre of the lower platform holding pin (see [Figure 1](#)).

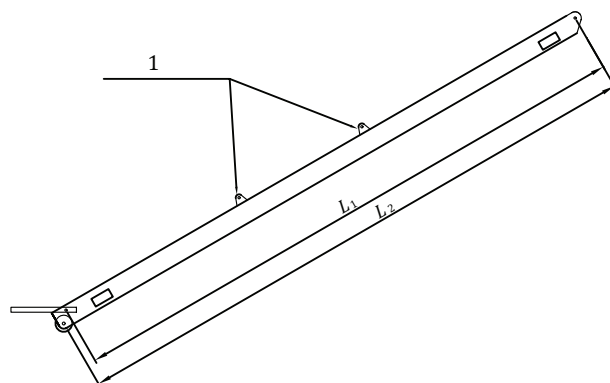

Key

- 1 intermediate suspension points
- L_1 nominal length
- L_2 design length

Figure 1 — Single-flight ladder

4.1.2 For a multi-flight ladder, the sum of the lengths L_3 and L_4 of the separate flights measured from the centre of the top pin to the centre of the lower pin in each case (see [Figure 2](#))

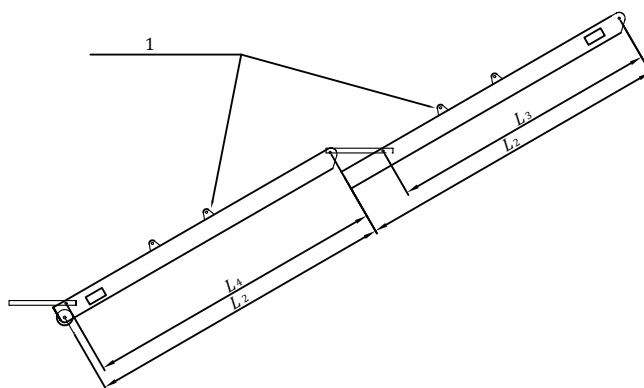

Key

- 1 intermediate suspension points
- L_1 nominal length, $L_1 = L_3 + L_4$
- L_2 design length, for each separate flight

Figure 2 — Multi-flight ladder

4.1.3 For a telescopic ladder, the maximum length is the sum of the lengths L_3 and L_4 minus overlap length l , i.e. from the centre of the top pin of the upper flight to the centre of the lower platform holding pin of the lower telescopic ladder (see [Figure 3](#)), the minimum retraction length, L_0 , is the sum of L_3 and l_1 (see [Figure 4](#)).

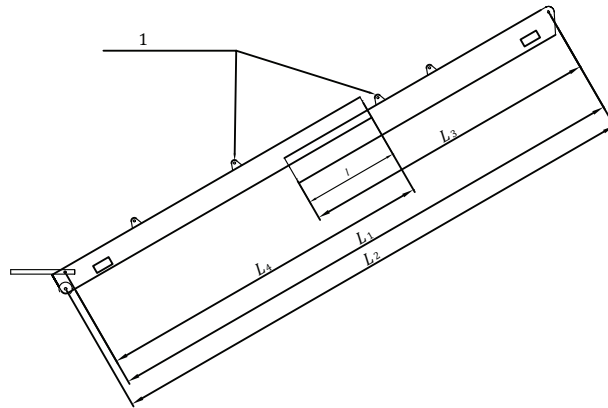

Key

1 intermediate suspension points

NOTE 1 Nominal length: L_1 .

NOTE 2 Maximum design telescopic: $L_2 = L_3 + L_4 - l$.

Figure 3 — Telescopic ladder

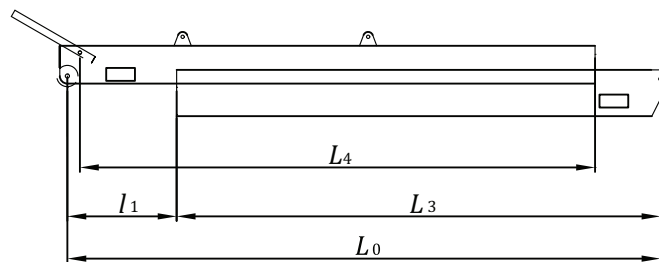

NOTE Minimum design retraction: $L_0 = L_3 + l_1$.

Figure 4 — Retraction diagram of telescopic ladder

4.2 Design length, L_2

The maximum distance between supporting points for each separate flight (see [Figure 1](#), [Figure 2](#) and [Figure 3](#)).

4.3 Width, b

The effective width of the walking surface (see [Figure 5](#)).

4.4 Handrail height, a

The vertical height of the handrail, measured from the highest point of the standing surface presented by the steps when the ladder is horizontal.

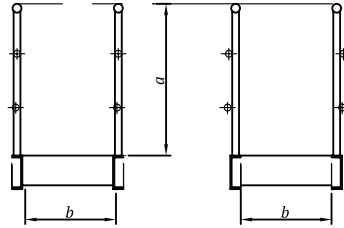

NOTE The sections shown are examples only.

Figure 5 — Minimum width, b , and handrail height, a

5 Dimensions

5.1 Nominal length, L_1

The range of nominal lengths shall be as follows:

- 3,6 m to 18 m in 0,6 m increments;
- above 18 m in 0,7 m increments.

5.2 Width, b

The width of all accommodation ladders shall be 600 mm.

5.3 Distance between steps

The distance between the steps, referring to the distance between the neighbouring steps when the ladder is horizontal, shall be not less than 300 mm and not more than 350 mm. It shall be 300 mm for the nominal length of not more than 18 m, and about 350 mm for the nominal length of more than 18 m.

5.4 Handrail height, a

The top handrail height, a , shall be not less than 1 000 mm. Two handrails evenly spaced at mid-height shall be provided.

5.5 Distance between stanchions

The distance between the neighbouring stanchions shall be not more than 1 500 mm.

6 Manufacture

6.1 Design

6.1.1 Minimum angle of use

Ladders of single-flight, multi-flight or telescopic types shall be designed for safe operation in a horizontal position.

6.1.2 Maximum angle of use

With the steps horizontal, the ladder shall operate safely at an angle of 55° from the horizontal. According to the requirements of IMO Resolution A.1045(27), the pilot accommodation ladder shall operate safely at an angle of 45° from the horizontal.

6.1.3 Design loading

6.1.3.1 The ladders shall be designed to support a uniform load equivalent to 735 N on every step when the ladder is in a horizontal position.

6.1.3.2 The pilot accommodation ladders shall be designed to support loads equivalent to 1470 N on intermediate two steps simultaneously when the ladder is horizontal.

6.1.4 Step design

6.1.4.1 The steps shall be designed to be anti-slip with the right profile (arc shape) and can operate at the inclination required in [6.1.2](#) while being light but rigid enough to withstand the average weight of men.

6.1.4.2 Individual steps shall be designed to withstand a central point load of 735 N.

6.1.5 Design loading for access and intermediate platforms

The platforms shall be designed to support a uniform loading of 4 000 N/m². The framework and supporting structure of the upper and intermediate platforms shall in addition be designed to carry the weight of the suspended ladder together with the design load given in [6.1.3](#).

6.1.6 Design loading for handrail

6.1.6.1 Handrails and supports shall be designed for a side loading at the upper handrail of 500 N/m without permanent deformation.

6.1.6.2 Where fixed handrails become one of the considerations in the integral strength design of ladder frame of the ladder, no permanent deformation has taken place for the handrail after the integral strength test is carried out for the ladder frame.

6.1.7 Support points

6.1.7.1 All support points (pivots, rollers, etc.) and suspension points (lugs, pulley yokes, brackets, etc.) shall be of adequate strength to support the weight of the ladder plus the loading stipulated in [6.1.3](#).

6.1.7.2 Pulley yokes of the suspension ladders on the two sides of the ladders and pilot accommodation ladders over 15m in length, shall be designed to meet the requirement of simultaneously hoisting at the two rope exits on one steel cable according to ISO 2408.

6.1.8 Strength and design of the ladder frame

The strength and design of the ladder frame shall be so as it will be anti-twist type.

6.1.9 Safety factor

The allowable stress used in the design of the ladder, with the loading specified in [6.1.3](#), shall be determined by applying a safety factor of 2 to the yield point for steel and to the 0.2 % proof stress for aluminium.

6.2 Materials

The ladder frame of the ladder shall be constructed from steel or aluminium in accordance with the table, but alternative materials may be used for these and other components provided that they are at least suitable in all respects for the intended duty and are equally acceptable to the purchaser (see [Table 1](#)).

Table 1 — Materials

Steel	ISO 630-1, Fe360B or equivalent
Aluminium	ISO 209:2007, AW-Al Mg5(AW-5019), AW-Al MgSi(AW-6060) or other suitable alloy

6.3 Surface requirements

6.3.1 The surface of steel parts of the ladder shall be provided with effective anti-corrosion measures.

6.3.2 Anodic oxidation treatment shall be made for the surface of aluminium parts of the ladder.

6.3.3 Appropriate methods shall be provided for contact of different metallic materials to prevent corrosion.

7 Quality or manufacture

7.1 The ladder shall be visibly free from defects or distortion.

7.2 All components shall be free from exposed rough or sharp edges likely to cause injury.

7.3 Care shall be taken in the treatment of aluminium or steel structures to ensure the mechanical properties of materials.

8 Testing

8.1 Procedure

A prototype of each design of ladder shall be tested in a horizontal position, simply supported at the ends of the design length L_2 (see [Figure 6](#)), to prove the longitudinal strength and to measure maximum deflection. In the case of multi-flight ladders, each separate flight shall be tested in a similar manner.

The ladder shall be loaded with a load equivalent to 735 N on every step. The pilot accommodation ladder shall be loaded with loads equivalent to 1470 N on the intermediate two steps simultaneously.

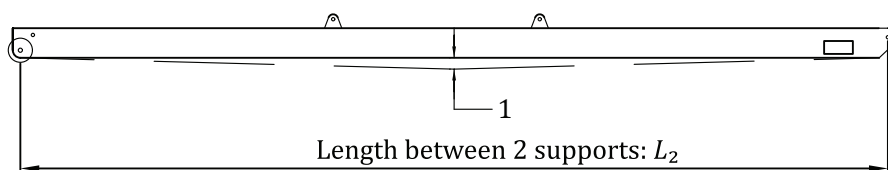

Key

1 maximum deflection

Figure 6 — Method of testing for each separate flight

8.2 Measure

8.2.1 The maximum deflection of each flight of a ladder when loaded shall not exceed $L_2/100$ for steel and $L_2/75$ for aluminium.

8.2.2 There is no twist or deformation of each flight of ladder.

9 Inspection

9.1 Ladders subjected to a loading test shall be inspected after testing to ensure that there are no signs of damage or that no permanent deformation has taken place.

9.2 All related equipment of ladders shall be visually checked after testing to ensure that there are no signs of residual defect or damage, and that

- a) there is no distortion of the platform and suspension,
- b) all suspension points, such as lugs and brackets are adequately secured,
- c) the roller or wheels revolve freely,
- d) for the collapsible guide fitted to the ladder, the stanchions, hand and intermediate guides can be easily erected in position; for the fixed guide fitted to the ladder, there are no signs of damage or no permanent deformation has taken place for the stanchions and handrails, and
- e) the rating plate is affixed and correct.

9.3 The steps shall be checked to ensure that they are provided with obvious anti-slip surfaces and can operate at the maximum inclination required for the ladder use.

10 Marking

According to SOLAS Regulation II-1/3-9, each ladder shall be marked with the following information prominently displayed at the two ends of the ladder frame:

- a) rules of safety operation and load limits, including maximum and minimum permitted design angle of inclination, design load, and platform load. For the pilot accommodation ladders, the prominent marking of maximum design load and design working load shall be added on the ladder frame;
- b) manufacturer's name or trademark;
- c) product name;
- d) product specification;
- e) date of manufacture;
- f) stamp of the ship inspection department.

Bibliography

- [1] REGULATION SOLAS II-1/3-9, Means of embarkation on and disembarkation from ships

British Standards Institution (BSI)

BSI is the national body responsible for preparing British Standards and other standards-related publications, information and services.

BSI is incorporated by Royal Charter. British Standards and other standardization products are published by BSI Standards Limited.

About us

We bring together business, industry, government, consumers, innovators and others to shape their combined experience and expertise into standards-based solutions.

The knowledge embodied in our standards has been carefully assembled in a dependable format and refined through our open consultation process. Organizations of all sizes and across all sectors choose standards to help them achieve their goals.

Information on standards

We can provide you with the knowledge that your organization needs to succeed. Find out more about British Standards by visiting our website at bsigroup.com/standards or contacting our Customer Services team or Knowledge Centre.

Buying standards

You can buy and download PDF versions of BSI publications, including British and adopted European and international standards, through our website at bsigroup.com/shop, where hard copies can also be purchased.

If you need international and foreign standards from other Standards Development Organizations, hard copies can be ordered from our Customer Services team.

Subscriptions

Our range of subscription services are designed to make using standards easier for you. For further information on our subscription products go to bsigroup.com/subscriptions.

With **British Standards Online (BSOL)** you'll have instant access to over 55,000 British and adopted European and international standards from your desktop. It's available 24/7 and is refreshed daily so you'll always be up to date.

You can keep in touch with standards developments and receive substantial discounts on the purchase price of standards, both in single copy and subscription format, by becoming a **BSI Subscribing Member**.

PLUS is an updating service exclusive to BSI Subscribing Members. You will automatically receive the latest hard copy of your standards when they're revised or replaced.

To find out more about becoming a BSI Subscribing Member and the benefits of membership, please visit bsigroup.com/shop.

With a **Multi-User Network Licence (MUNL)** you are able to host standards publications on your intranet. Licences can cover as few or as many users as you wish. With updates supplied as soon as they're available, you can be sure your documentation is current. For further information, email bsmusales@bsigroup.com.

BSI Group Headquarters

389 Chiswick High Road London W4 4AL UK

Revisions

Our British Standards and other publications are updated by amendment or revision.

We continually improve the quality of our products and services to benefit your business. If you find an inaccuracy or ambiguity within a British Standard or other BSI publication please inform the Knowledge Centre.

Copyright

All the data, software and documentation set out in all British Standards and other BSI publications are the property of and copyrighted by BSI, or some person or entity that owns copyright in the information used (such as the international standardization bodies) and has formally licensed such information to BSI for commercial publication and use. Except as permitted under the Copyright, Designs and Patents Act 1988 no extract may be reproduced, stored in a retrieval system or transmitted in any form or by any means – electronic, photocopying, recording or otherwise – without prior written permission from BSI. Details and advice can be obtained from the Copyright & Licensing Department.

Useful Contacts:

Customer Services

Tel: +44 845 086 9001

Email (orders): orders@bsigroup.com

Email (enquiries): cservices@bsigroup.com

Subscriptions

Tel: +44 845 086 9001

Email: subscriptions@bsigroup.com

Knowledge Centre

Tel: +44 20 8996 7004

Email: knowledgecentre@bsigroup.com

Copyright & Licensing

Tel: +44 20 8996 7070

Email: copyright@bsigroup.com



...making excellence a habit.™