

BS ISO 4696-1:2015



BSI Standards Publication

Iron ores for blast furnace feedstocks — Determination of low-temperature reduction-disintegration indices by static method

Part 1: Reduction with CO, CO₂, H₂ and N₂

bsi.

...making excellence a habit.™

National foreword

This British Standard is the UK implementation of ISO 4696-1:2015. It supersedes BS ISO 4696-1:2007 which is withdrawn.

The UK participation in its preparation was entrusted to Technical Committee ISE/58, Iron ores.

A list of organizations represented on this committee can be obtained on request to its secretary.

This publication does not purport to include all the necessary provisions of a contract. Users are responsible for its correct application.

© The British Standards Institution 2015. Published by BSI Standards Limited 2015

ISBN 978 0 580 79284 7

ICS 73.060.10

Compliance with a British Standard cannot confer immunity from legal obligations.

This British Standard was published under the authority of the Standards Policy and Strategy Committee on 31 August 2015.

Amendments issued since publication

Date	Text affected
------	---------------

**Iron ores for blast furnace
feedstocks — Determination of low-
temperature reduction-disintegration
indices by static method —**

**Part 1:
Reduction with CO, CO₂, H₂ and N₂**

*Minerais de fer pour charges de hauts fourneaux — Détermination
des indices de désagrégation par réduction à basse température par
méthode statique —*

Partie 1: Réduction avec CO, CO₂, H₂ et N₂





COPYRIGHT PROTECTED DOCUMENT

© ISO 2015, Published in Switzerland

All rights reserved. Unless otherwise specified, no part of this publication may be reproduced or utilized otherwise in any form or by any means, electronic or mechanical, including photocopying, or posting on the internet or an intranet, without prior written permission. Permission can be requested from either ISO at the address below or ISO's member body in the country of the requester.

ISO copyright office
Ch. de Blandonnet 8 • CP 401
CH-1214 Vernier, Geneva, Switzerland
Tel. +41 22 749 01 11
Fax +41 22 749 09 47
copyright@iso.org
www.iso.org

Contents

	Page
Foreword	iv
Introduction	v
1 Scope	1
2 Normative references	1
3 Terms and definitions	1
4 Principle	1
5 Sampling, sample preparation, and preparation of test portions	2
5.1 Sampling and sample preparation.....	2
5.2 Preparation of test portions.....	2
6 Apparatus	2
6.1 General.....	2
7 Test conditions	3
7.1 General.....	3
7.2 Reducing gas.....	3
7.2.1 Composition.....	3
7.2.2 Purity.....	4
7.2.3 Flow rate.....	4
7.3 Heating and cooling gas.....	4
7.4 Temperature of the test portion.....	4
8 Procedure	4
8.1 Number of determinations for the test.....	4
8.2 Reduction.....	4
8.3 Tumbling.....	5
8.4 Sieving.....	5
9 Expression of results	5
9.1 Calculation of the reduction-disintegration indices (RDI-1 _{+6,3} , RDI-1 _{-3,15} , RDI-1 _{-0,5}).....	5
9.2 Repeatability and acceptance of test results.....	5
10 Test report	6
11 Verification	6
Annex A (normative) Flowsheet of the procedure for the acceptance of test results	11

Foreword

ISO (the International Organization for Standardization) is a worldwide federation of national standards bodies (ISO member bodies). The work of preparing International Standards is normally carried out through ISO technical committees. Each member body interested in a subject for which a technical committee has been established has the right to be represented on that committee. International organizations, governmental and non-governmental, in liaison with ISO, also take part in the work. ISO collaborates closely with the International Electrotechnical Commission (IEC) on all matters of electrotechnical standardization.

The procedures used to develop this document and those intended for its further maintenance are described in the ISO/IEC Directives, Part 1. In particular the different approval criteria needed for the different types of ISO documents should be noted. This document was drafted in accordance with the editorial rules of the ISO/IEC Directives, Part 2 (see www.iso.org/directives).

Attention is drawn to the possibility that some of the elements of this document may be the subject of patent rights. ISO shall not be held responsible for identifying any or all such patent rights. Details of any patent rights identified during the development of the document will be in the Introduction and/or on the ISO list of patent declarations received (see www.iso.org/patents).

Any trade name used in this document is information given for the convenience of users and does not constitute an endorsement.

For an explanation on the meaning of ISO specific terms and expressions related to conformity assessment, as well as information about ISO's adherence to the WTO principles in the Technical Barriers to Trade (TBT), see the following URL: [Foreword — Supplementary information](#)

The committee responsible for this document is ISO/TC 102, *Iron ore and direct reduced iron*, Subcommittee SC 3, *Physical testing*.

This third edition cancels and replaces the second edition (ISO 4696-1:2007), which has been technically revised to address the care needed during hand sieving, to introduce the mechanical sieving and to exclude the reference to ISO 4701.

ISO 4696 consists of the following parts, under the general title *Iron ores for blast furnace feedstocks — Determination of low-temperature reduction-disintegration indices by static method*:

- *Part 1: Reduction with CO, CO₂, H₂ and N₂*
- *Part 2: Reduction with CO and N₂*

Introduction

This part of ISO 4696 concerns one of a number of physical test methods that have been developed to measure various physical parameters and to evaluate the behaviour of iron ores, including reducibility, disintegration, crushing strength, apparent density, etc. This method was developed to provide a uniform procedure, validated by collaborative testing, to facilitate comparisons of tests made in different laboratories.

The results of this test have to be considered in conjunction with other tests used to evaluate the quality of iron ores as feedstocks for blast furnace processes.

This part of ISO 4696 can be used to provide test results as part of a production quality control system, as a basis of a contract, or as part of a research project.

Iron ores for blast furnace feedstocks — Determination of low-temperature reduction-disintegration indices by static method —

Part 1: Reduction with CO, CO₂, H₂ and N₂

CAUTION — This International Standard may involve hazardous operations and equipment. This standard does not purport to address all of the safety issues associated with its use. It is the responsibility of the user of this International Standard to establish appropriate safety and health practices and determine the applicability of regulatory limitations prior to its use.

1 Scope

This part of ISO 4696 specifies a method to provide a relative measure for evaluating the degree of size degradation of iron ores when reduced with carbon monoxide, carbon dioxide, hydrogen, and nitrogen, under conditions resembling those prevailing in the low-temperature reduction zone of a blast furnace.

This part of ISO 4696 is applicable to lump ores, sinters, and hot-bonded pellets.

2 Normative references

The following documents, in whole or in part, are normatively referenced in this document and are indispensable for its application. For dated references, only the edition cited applies. For undated references, the latest edition of the referenced document (including any amendments) applies.

ISO 3082, *Iron ores — Sampling and sample preparation procedures*

ISO 3310-1, *Test sieves — Technical requirements and testing — Part 1: Test sieves of metal wire cloth*

ISO 3310-2, *Test sieves — Technical requirements and testing — Part 2: Test sieves of perforated metal plate*

ISO 11323, *Iron ore and direct reduced iron — Vocabulary*

3 Terms and definitions

For the purposes of this document, the terms and definitions given in ISO 11323 apply.

4 Principle

The test portion is isothermally reduced in a fixed bed, at 500 °C, using a reducing gas consisting of CO, CO₂, H₂, and N₂, for 60 min. The reduced test portion is tumbled in a specific tumble drum for 300 revolutions and then sieved with sieves having square openings of 6,30 mm, 3,15 mm, and 500 µm. Three reduction-disintegration indices (RDI) are calculated as the mass percentage of material greater than 6,30 mm, less than 3,15 mm, and less than 500 µm.

5 Sampling, sample preparation, and preparation of test portions

5.1 Sampling and sample preparation

Sampling of a lot and preparation of a test sample shall be in accordance with ISO 3082.

The size range for pellets, sinters, and lump ores shall be $- 12,5 \text{ mm} + 10,0 \text{ mm}$.

A test sample of at least 2 kg, on a dry basis, of the sized material shall be obtained.

Oven-dry the test sample to constant mass at $105 \text{ °C} \pm 5 \text{ °C}$ and cool it to room temperature before preparation of the test portions.

NOTE Constant mass is achieved when the difference in mass between two subsequent measurements becomes less than 0,05 % of the initial mass of the test sample.

5.2 Preparation of test portions

Collect each test portion by taking ore particles at random.

NOTE Manual methods of division recommended in ISO 3082, such as riffing, can be applied to obtain the test portions.

At least four test portions, each of approximately 500 g (\pm the mass of 1 particle) shall be prepared from the test sample.

Weigh the test portions to the nearest 0,1 g and register the mass of each test portion on its recipient label.

6 Apparatus

6.1 General

The test apparatus shall comprise the following:

- a) ordinary laboratory equipment, such as an oven, hand tools, a time-control device, and safety equipment;
- b) reduction-tube assembly;
- c) furnace;
- d) system to supply the gases and regulate the flow rates;
- e) tumble drum;
- f) test sieves;
- g) weighing device.

[Figure 1](#) shows an example of the test apparatus.

6.2 Reduction tube, made of non-scaling, heat-resistant metal to withstand temperatures higher than 600 °C, and resistant to deformation.

The internal diameter shall be $75 \text{ mm} \pm 1 \text{ mm}$. A removable perforated plate made of non-scaling, heat-resistant metal to withstand temperatures higher than 600 °C shall be mounted in the reduction tube to support the test portion and to ensure uniform gas flow through it. The perforated plate shall be 4 mm thick, with a diameter 1 mm less than the internal diameter of the tube. The holes in the plate shall be 2 mm to 3 mm in diameter at a pitch centre distance of 4 mm to 5 mm.

[Figure 2](#) shows an example of a reduction tube.

6.3 Furnace, having a heating capacity and temperature control able to maintain the entire test portion, as well as gas entering the bed, at $500\text{ °C} \pm 5\text{ °C}$.

6.4 Porcelain balls, having a size range between 10,0 mm and 12,5 mm and of sufficient quantity to form a double-layer bed on the perforated plate.

6.5 Gas-supply system, capable of supplying the gases and regulating gas flow rates.

6.6 Tumble drum, made of steel, at least 5 mm thick, having an internal diameter of 130 mm and an inside length of 200 mm.

Two equally spaced steel lifters (200 mm long, 20 mm high, and 2 mm thick) shall be mounted longitudinally inside the drum. These can be mounted on a frame that can be inserted inside the vessel from one end. One end of the drum shall be closed and the other open. A close-fitting lid shall be held in place on the opening to ensure a dust-tight seal. The drum shall be replaced in any case when the thickness of the vessel wall is reduced to 3 mm in any area, and the lifters when their height is reduced to less than 18 mm.

[Figure 3](#) shows an example of a tumble drum.

6.7 Rotation equipment, capable of ensuring that the drum attains full speed in one revolution, rotates at a constant speed of $30\text{ r/min} \pm 1\text{ r/min}$ and stops within one revolution.

The equipment shall be fitted with a revolution counter and with an automatic device for stopping the drum after a predetermined number of revolutions.

6.8 Test sieves, conforming to ISO 3310-1 or ISO 3310-2 and having square apertures of the following nominal sizes: 6,30 mm; 3,15 mm, and $500\text{ }\mu\text{m}$.

6.9 Weighing device, capable of weighing the test sample and test portions to an accuracy of 0,1 g.

7 Test conditions

7.1 General

Volumes and flow rates of gases are as measured at a reference temperature of 0 °C and at a reference atmospheric pressure of 101,325 kPa (1,013 25 bar).

7.2 Reducing gas

7.2.1 Composition

The reducing gas shall consist of the following:

CO	$20,0\% \pm 0,5\%$ (volume fraction)
CO ₂	$20,0\% \pm 0,5\%$ (volume fraction)
H ₂	$2,0\% \pm 0,5\%$ (volume fraction)
N ₂	$58,0\% \pm 0,5\%$ (volume fraction)

7.2.2 Purity

Impurities in the reducing gas shall not exceed the following:

O₂ 0,1 % (volume fraction)

H₂O 0,2 % (volume fraction)

7.2.3 Flow rate

The flow rate of the reducing gas, during the entire reducing period, shall be maintained at 20 L/min ± 1 L/min.

7.3 Heating and cooling gas

Nitrogen (N₂) shall be used as the heating and cooling gas. Impurities shall not exceed 0,1 % (volume fraction).

The flow rate of N₂ shall be maintained at 5 L/min until the test portion reaches 500 °C, and at 20 L/min during the temperature-equilibration period. During cooling, it shall be maintained at 5 L/min.

7.4 Temperature of the test portion

The temperature of the entire test portion shall be maintained at 500 °C ± 5 °C during the entire reducing period and, as such, the reducing gas shall be preheated before entering the test portion.

8 Procedure

8.1 Number of determinations for the test

Carry out the test as many times as required by the procedure in [Annex A](#).

8.2 Reduction

Place a double-layer bed of porcelain balls ([6.4](#)) in the reduction tube ([6.2](#)) on the perforated plate.

Take, at random, one of the test portions prepared in [5.2](#). Place it in the reduction tube ([6.2](#)) and level its surface.

Close the top of the reduction tube. Connect the thermocouple, ensuring that its tip is in the centre of the test portion.

Insert the reduction tube into the furnace ([6.3](#)).

Connect the gas-supply system ([6.5](#)).

Pass a flow of N₂ through the test portion at a rate of at least 5 L/min and commence heating. When the temperature of the test portion approaches 500 °C, increase the flow rate to 20 L/min. Continue heating while maintaining the flow of N₂ until the test portion reaches 500 °C ± 5 °C. Allow a period of 15 min for temperature equilibration at 500 °C.

DANGER — Carbon monoxide and the reducing gas, which contains carbon monoxide, are toxic and therefore hazardous. Testing shall be carried out in a well ventilated area or under a hood. Precautions should be taken for the safety of the operator, in accordance with the safety codes of each country.

Introduce the reducing gas at a flow rate of 20 L/min ± 1 L/min to replace the N₂. After 60 min of reduction, turn off the power. Replace the reducing gas with N₂ at a flow rate of 5 L/min and cool the test portion to a temperature below 100 °C.

8.3 Tumbling

Remove the test portion carefully from the reduction tube. Determine its mass (m_0) and place it in the tumble drum (6.6). Fasten the lid tightly and rotate the drum for a total of 300 revolutions at a rate of 30 r/min \pm 1 r/min.

8.4 Sieving

Remove all material from the drum, determine and record the mass and hand sieve with care on 6,30 mm, 3,15 mm, and 500 μ m sieves. Determine and record the mass of each fraction retained on the 6,30 mm (m_1), 3,15 mm (m_2), and 500 μ m (m_3) sieves. Material lost during tumbling and sieving shall be considered to be part of the – 500 μ m fraction.

NOTE Equivalent mechanical sieving can be used provided that preliminary test programme is carried out according to ISO 3086, having as reference the hand sieving method.

Sieving results are influenced by the sieve shaker characteristics. Therefore, in cases in which two or more laboratories need to compare their results for commercial or research purposes, they should adjust the sieving conditions until they obtain identical results for the same test sample.

9 Expression of results

9.1 Calculation of the reduction-disintegration indices (RDI-1_{+6,3}, RDI-1_{-3,15}, RDI-1_{-0,5})

The reduction-disintegration indices, RDI-1_{+6,3}, RDI-1_{-3,15}, RDI-1_{-0,5}, expressed as percentages by mass, are calculated from the following formulae:

$$\text{RDI} - 1_{+6,3} = \frac{m_1}{m_0} \times 100 \quad (1)$$

$$\text{RDI} - 1_{-3,15} = \frac{m_0 - (m_1 + m_2)}{m_0} \times 100 \quad (2)$$

$$\text{RDI} - 1_{-0,5} = \frac{m_0 - (m_1 + m_2 + m_3)}{m_0} \times 100 \quad (3)$$

where

m_0 is the mass, in grams, of the test portion after reduction and before tumbling;

m_1 is the mass, in grams, of the fraction retained on the 6,30 mm sieve;

m_2 is the mass, in grams, of the fraction retained on the 3,15 mm sieve;

m_3 is the mass, in grams, of the fraction retained on the 500 μ m sieve.

Record each result to one decimal place.

9.2 Repeatability and acceptance of test results

Follow the procedure of [Annex A](#), for each of the RDI-1 indices, by using the repeatability values given in [Table 1](#). The results shall be reported to one decimal place.

Table 1 — Repeatability (*r*)

Mean value of RDI-1 %	<i>r</i> (%, absolute)
0	0
5	1,0
10	2,0
15	3,0
20	4,0
25	4,0
50	4,0
75	4,0
80	4,0
85	3,0
90	2,0
95	1,0
100	0

10 Test report

The test report shall include the following information:

- a) a reference to this part of ISO 4696, i.e. ISO 4696-1:2015;
- b) all details necessary for the identification of the sample;
- c) the name and address of the test laboratory;
- d) the date of the test;
- e) the date of the test report;
- f) the signature of the person responsible for the test;
- g) the details of any operation and any test conditions not specified in this part of ISO 4696 or regarded as optional, as well as any incident which could have had an influence on the results;
- h) the reduction-disintegration indices, RDI-1_{+6,3}, RDI-1_{-3,15}, RDI-1_{-0,5};
- i) the sieving conditions, e.g. the method of sieving and the sieving time;
- j) the total mass of the material inserted into the tumble drum and taken from the tumble drum;
- k) the type of sieve used.

11 Verification

Regular checking of apparatus is essential to ensure test result reliability. The frequency of checking is a matter for each laboratory to determine.

The conditions of the following items shall be checked:

- sieves;
- weighing device;

- reduction tube;
- temperature control and measurement devices;
- gas flow meters;
- purity of gases;
- time-control device;
- tumble drum;
- drum-rotation equipment.

It is recommended that the internal reference material be prepared and used periodically to check test repeatability.

Appropriate records of verification activities shall be maintained.

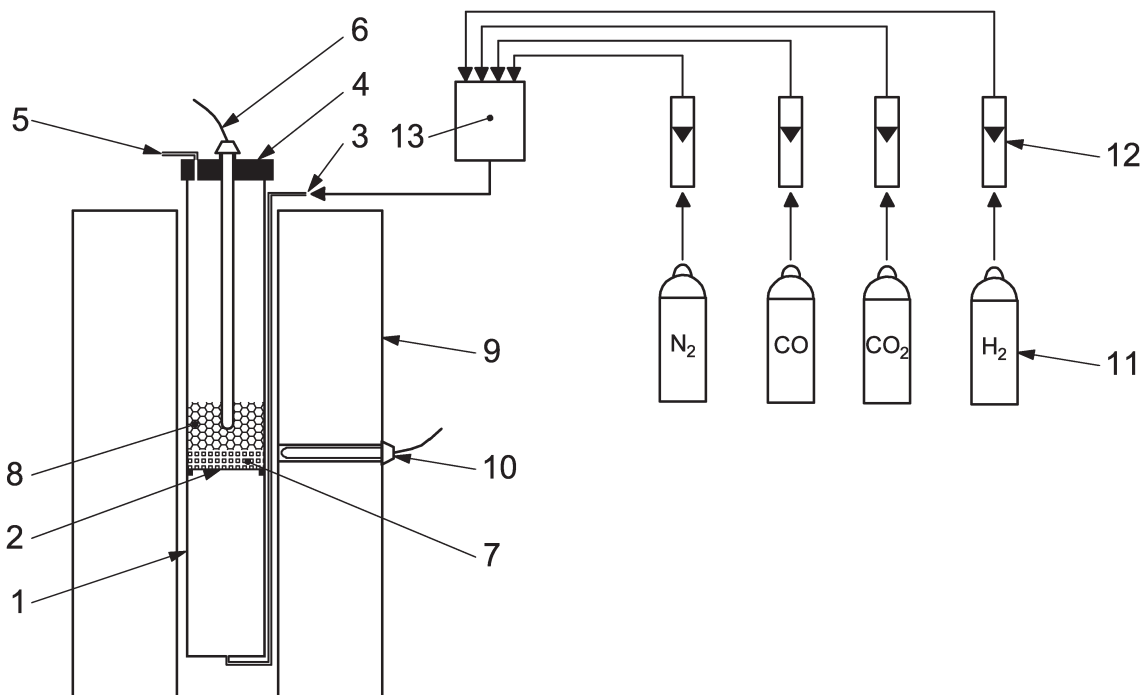

Key

Reduction tube

- 1 reduction tube wall
- 2 perforated plate
- 3 gas inlet
- 4 lid
- 5 gas outlet
- 6 thermocouple for measuring the reduction temperature
- 7 porcelain ball layer
- 8 test portion

Furnace

- 9 electrically heated furnace
- 10 thermocouple for temperature regulation of furnace

Gas supply system

- 11 gas cylinders
- 12 gas flow meters
- 13 mixing vessel

Figure 1 — Example of test apparatus (schematic diagram)

Dimensions in millimetres

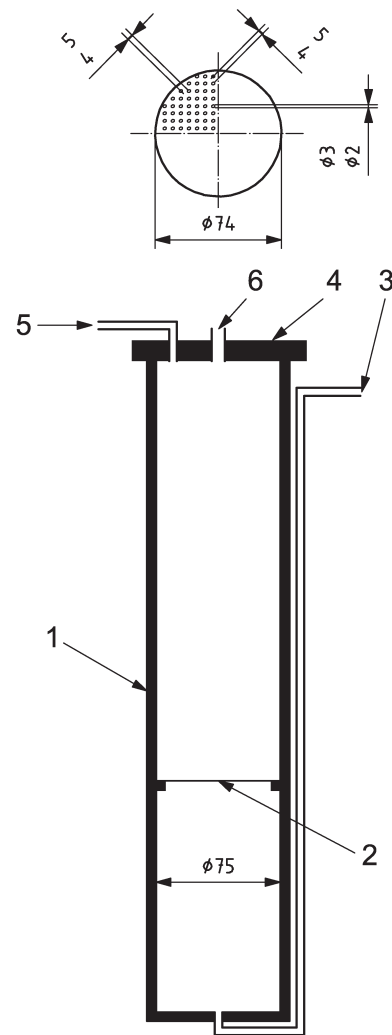

Key

- 1 reduction tube wall
- 2 perforated plate
- 3 opening for gas inlet
- 4 lid
- 5 opening for gas outlet
- 6 opening for thermocouple insertion

NOTE Dimensions not specified in the apparatus clause are shown for information only.

Figure 2 — Example of a reduction tube (schematic diagram)

Dimensions in millimetres

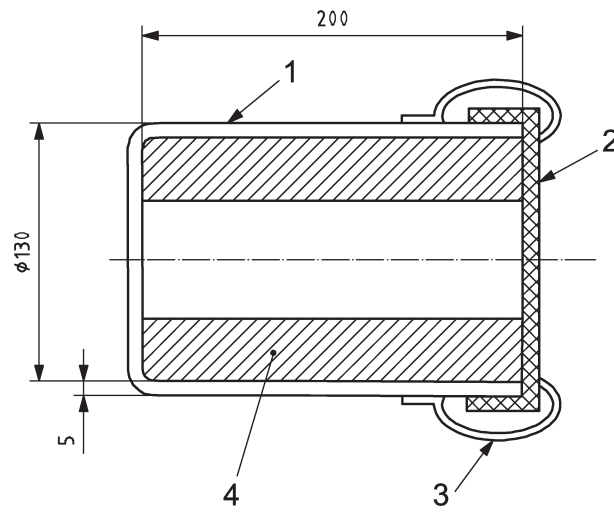

Key

- 1 vessel
- 2 lid
- 3 clamps
- 4 frame with lifters

NOTE Lifters: 20 mm high by 2 mm thick plain; Material: plain carbon steel.

Figure 3 — Example of RDI tumble drum (schematic diagram)

Annex A (normative)

Flowsheet of the procedure for the acceptance of test results

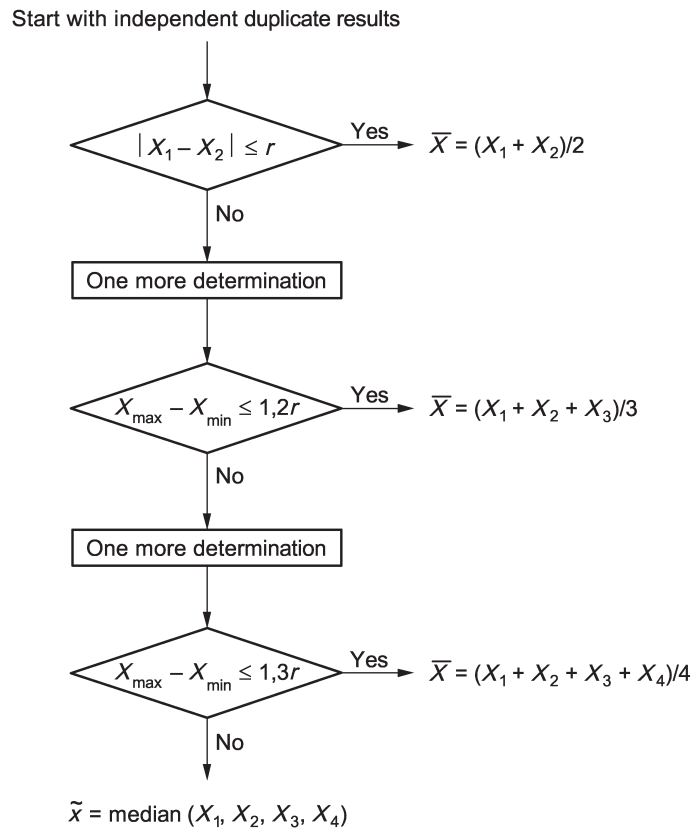

NOTE r : see [Table 1](#)

British Standards Institution (BSI)

BSI is the national body responsible for preparing British Standards and other standards-related publications, information and services.

BSI is incorporated by Royal Charter. British Standards and other standardization products are published by BSI Standards Limited.

About us

We bring together business, industry, government, consumers, innovators and others to shape their combined experience and expertise into standards-based solutions.

The knowledge embodied in our standards has been carefully assembled in a dependable format and refined through our open consultation process. Organizations of all sizes and across all sectors choose standards to help them achieve their goals.

Information on standards

We can provide you with the knowledge that your organization needs to succeed. Find out more about British Standards by visiting our website at bsigroup.com/standards or contacting our Customer Services team or Knowledge Centre.

Buying standards

You can buy and download PDF versions of BSI publications, including British and adopted European and international standards, through our website at bsigroup.com/shop, where hard copies can also be purchased.

If you need international and foreign standards from other Standards Development Organizations, hard copies can be ordered from our Customer Services team.

Subscriptions

Our range of subscription services are designed to make using standards easier for you. For further information on our subscription products go to bsigroup.com/subscriptions.

With **British Standards Online (BSOL)** you'll have instant access to over 55,000 British and adopted European and international standards from your desktop. It's available 24/7 and is refreshed daily so you'll always be up to date.

You can keep in touch with standards developments and receive substantial discounts on the purchase price of standards, both in single copy and subscription format, by becoming a **BSI Subscribing Member**.

PLUS is an updating service exclusive to BSI Subscribing Members. You will automatically receive the latest hard copy of your standards when they're revised or replaced.

To find out more about becoming a BSI Subscribing Member and the benefits of membership, please visit bsigroup.com/shop.

With a **Multi-User Network Licence (MUNL)** you are able to host standards publications on your intranet. Licences can cover as few or as many users as you wish. With updates supplied as soon as they're available, you can be sure your documentation is current. For further information, email bsmusales@bsigroup.com.

BSI Group Headquarters

389 Chiswick High Road London W4 4AL UK

Revisions

Our British Standards and other publications are updated by amendment or revision.

We continually improve the quality of our products and services to benefit your business. If you find an inaccuracy or ambiguity within a British Standard or other BSI publication please inform the Knowledge Centre.

Copyright

All the data, software and documentation set out in all British Standards and other BSI publications are the property of and copyrighted by BSI, or some person or entity that owns copyright in the information used (such as the international standardization bodies) and has formally licensed such information to BSI for commercial publication and use. Except as permitted under the Copyright, Designs and Patents Act 1988 no extract may be reproduced, stored in a retrieval system or transmitted in any form or by any means – electronic, photocopying, recording or otherwise – without prior written permission from BSI. Details and advice can be obtained from the Copyright & Licensing Department.

Useful Contacts:

Customer Services

Tel: +44 845 086 9001

Email (orders): orders@bsigroup.com

Email (enquiries): cservices@bsigroup.com

Subscriptions

Tel: +44 845 086 9001

Email: subscriptions@bsigroup.com

Knowledge Centre

Tel: +44 20 8996 7004

Email: knowledgecentre@bsigroup.com

Copyright & Licensing

Tel: +44 20 8996 7070

Email: copyright@bsigroup.com



...making excellence a habit.™