

BS ISO 4689-2:2017



BSI Standards Publication

Iron ores — Determination of sulfur content

Part 2: Combustion/titration method

National foreword

This British Standard is the UK implementation of ISO 4689-2:2017. It supersedes BS ISO 4689-2:2015 which is withdrawn.

The UK participation in its preparation was entrusted to Technical Committee ISE/58, Iron ores.

A list of organizations represented on this committee can be obtained on request to its secretary.

This publication does not purport to include all the necessary provisions of a contract. Users are responsible for its correct application.

© The British Standards Institution 2017.
Published by BSI Standards Limited 2017

ISBN 978 0 580 95541 9

ICS 73.060.10

Compliance with a British Standard cannot confer immunity from legal obligations.

This British Standard was published under the authority of the Standards Policy and Strategy Committee on 31 March 2017.

Amendments/corrigenda issued since publication

Date	Text affected
------	---------------

INTERNATIONAL
STANDARD

BS ISO 4689-2:2017

ISO
4689-2

Third edition
2017-03

**Iron ores — Determination of sulfur
content —**

Part 2:
Combustion/titration method

Minerais de fer — Dosage du soufre —

Partie 2: Méthode par combustion et titration



Reference number
ISO 4689-2:2017(E)

© ISO 2017



COPYRIGHT PROTECTED DOCUMENT

© ISO 2017, Published in Switzerland

All rights reserved. Unless otherwise specified, no part of this publication may be reproduced or utilized otherwise in any form or by any means, electronic or mechanical, including photocopying, or posting on the internet or an intranet, without prior written permission. Permission can be requested from either ISO at the address below or ISO's member body in the country of the requester.

ISO copyright office
Ch. de Blandonnet 8 • CP 401
CH-1214 Vernier, Geneva, Switzerland
Tel. +41 22 749 01 11
Fax +41 22 749 09 47
copyright@iso.org
www.iso.org

Contents

	Page
Foreword	iv
Introduction	v
1 Scope	1
2 Normative references	1
3 Terms and definitions	1
4 Principle	1
5 Reagents	2
6 Apparatus	2
7 Sampling and samples	5
7.1 Laboratory sample.....	5
7.2 Preparation of predried test samples.....	5
8 Procedure	5
8.1 Number of determinations.....	5
8.2 Test portion.....	5
8.3 Blank test and check test.....	5
8.4 Determination.....	6
9 Expression of results	7
9.1 Calculation of sulfur content.....	7
9.2 General treatment of results.....	7
9.2.1 Repeatability and permissible tolerance.....	7
9.2.2 Determination of analytical result.....	8
9.2.3 Between-laboratories precision.....	8
9.2.4 Check for trueness.....	8
9.2.5 Calculation of final result.....	9
10 Test report	9
Annex A (normative) Flowsheet of the procedure for the acceptance of analytical values for test samples	11
Annex B (informative) Derivation of repeatability and permissible tolerance equations	12
Annex C (informative) Precision data obtained by international analytical trial	13
Bibliography	14

Foreword

ISO (the International Organization for Standardization) is a worldwide federation of national standards bodies (ISO member bodies). The work of preparing International Standards is normally carried out through ISO technical committees. Each member body interested in a subject for which a technical committee has been established has the right to be represented on that committee. International organizations, governmental and non-governmental, in liaison with ISO, also take part in the work. ISO collaborates closely with the International Electrotechnical Commission (IEC) on all matters of electrotechnical standardization.

The procedures used to develop this document and those intended for its further maintenance are described in the ISO/IEC Directives, Part 1. In particular the different approval criteria needed for the different types of ISO documents should be noted. This document was drafted in accordance with the editorial rules of the ISO/IEC Directives, Part 2 (see www.iso.org/directives).

Attention is drawn to the possibility that some of the elements of this document may be the subject of patent rights. ISO shall not be held responsible for identifying any or all such patent rights. Details of any patent rights identified during the development of the document will be in the Introduction and/or on the ISO list of patent declarations received (see www.iso.org/patents).

Any trade name used in this document is information given for the convenience of users and does not constitute an endorsement.

For an explanation on the voluntary nature of standards, the meaning of ISO specific terms and expressions related to conformity assessment, as well as information about ISO's adherence to the World Trade Organization (WTO) principles in the Technical Barriers to Trade (TBT) see the following URL: www.iso.org/iso/foreword.html.

This document was prepared by Technical Committee ISO/TC 102, *Iron ore and direct reduced iron*, Subcommittee SC 2, *Chemical analysis*.

This third edition cancels and replaces the second edition (ISO 4689-2:2015), which constitutes a minor revision with the following changes:

- [6.7](#): first line, after “approximately”, insert “10 g”;
- [9.2.4](#): modify [Formula \(7\)](#) and the relevant descriptions, to harmonize this subclause across all standards for which ISO/TC 102/SC 2 is responsible.

A list of all parts in the ISO 4689 series can be found on the ISO website.

Introduction

This document was originally published as ISO 4690:1986. Under a policy of rationalization of the numbering system used in ISO/TC 102, it has been decided to re-designate this document as ISO 4689-2. It was further decided to introduce a combustion/infrared method, numbered ISO 4689-3.

When next revised, ISO 4689:1986 will be re-designated as ISO 4689-1.

Iron ores — Determination of sulfur content —

Part 2: Combustion/titration method

WARNING — This document may involve hazardous materials, operations, and equipment. This document does not purport to address all of the safety problems associated with its use. It is the responsibility of the user of this document to establish appropriate health and safety practices and determine the applicability of regulatory limitations prior to use.

1 Scope

This document specifies a combustion/titration method for the determination of the sulfur content of iron ores.

This method is applicable to sulfur contents between 0,002 % (mass fraction) and 0,25 % (mass fraction) in natural iron ores, iron ore concentrates, and agglomerates, including sinter products. The results are not affected by the presence of fluoride.

2 Normative references

The following documents are referred to in the text in such a way that some or all of their content constitutes requirements of this document. For dated references, only the edition cited applies. For undated references, the latest edition of the referenced document (including any amendments) applies.

ISO 385, *Laboratory glassware — Burettes*

ISO 648, *Laboratory glassware — Single-volume pipettes*

ISO 1042, *Laboratory glassware — One-mark volumetric flasks*

ISO 2596, *Iron ores — Determination of hygroscopic moisture in analytical samples — Gravimetric, Karl Fischer and mass-loss methods*

ISO 3082, *Iron ores — Sampling and sample preparation procedures*

ISO 7764, *Iron ores — Preparation of predried test samples for chemical analysis*

ISO Guide 35, *Reference materials — General and statistical principles for certification*

3 Terms and definitions

No terms and definitions are listed in this document.

ISO and IEC maintain terminological databases for use in standardization at the following addresses:

— IEC Electropedia: available at <http://www.electropedia.org/>

— ISO Online browsing platform: available at <http://www.iso.org/obp>

4 Principle

The sample is mixed with tungsten(VI) oxide and heated at 1 200 °C in a resistance furnace, using nitrogen as a carrier gas.

The evolved sulfur dioxide is absorbed in dilute hydrochloric acid solution containing starch and potassium iodide, and the solution is titrated continuously during evolution with a standard volumetric solution of potassium iodate.

5 Reagents

During analysis, use only reagents of recognized analytical grade, and only distilled water or water of equivalent purity.

5.1 Magnesium perchlorate, $\text{Mg}(\text{ClO}_4)_2$, anhydrous, free flowing, particle size 0,5 mm to 2 mm.

5.2 Tungsten(VI) oxide, (WO_3) .

5.3 Tin(II) chloride, $\text{SnCl}_2 \cdot 2\text{H}_2\text{O}$, particle size 0,5 mm to 2 mm.

5.4 Sodium hydroxide coated silica, particle size 0,5 mm to 2 mm.

5.5 Hydrochloric acid, ρ , 1,16 g/ml to 1,19 g/ml, diluted 1 + 66.

5.6 Potassium iodide, KI, 3 % (mass fraction) solution.

5.7 Starch, 2 % (mass fraction) solution.

Make a suspension of 2,0 g of starch in 10 ml of water, add to 50 ml of boiling water and stir. Cool, dilute to 100 ml and mix.

Prepare this solution immediately prior to use.

5.8 Potassium iodate, KIO_3 , standard volumetric solution, 0,001 042 mol/l.

The potassium iodate should be previously dried for 2 h at 130 °C.

Weigh, to the nearest 0,000 2 g, 0,223 g of dried potassium iodate and dissolve in water. Cool, transfer to a 1 l volumetric flask, dilute to volume and mix.

1 ml of this standard volumetric solution is equivalent to 0,10 mg of sulfur.

6 Apparatus

Ordinary laboratory apparatus, including one-mark pipettes and one-mark volumetric flasks complying with the specifications of ISO 648 and ISO 1042 respectively, as well as the following. See [Figure 1](#).

6.1 Nitrogen supply.

6.2 Drying tower, containing sodium hydroxide coated silica ([5.4](#)) and magnesium perchlorate ([5.1](#)).

6.3 Flowmeter, graduated from 0 to 1 l/min.

6.4 Resistance furnace, capable of maintaining a temperature of $1\,200\text{ °C} \pm 25\text{ °C}$.

6.5 Refractory combustion tube, capable of withstanding a temperature of $1\,200\text{ °C} \pm 25\text{ °C}$.

6.6 Refractory combustion boat, with loose-fitting lid, or a suitable refractory combustion boat capable of accommodating a porous cartridge, as shown in [Figure 2](#) a) or b) respectively.

The following dimensions can be used as guidelines.

Combustion boat		Cartridge	
Length	80 mm	Length	50 mm
Width	13 mm	Internal diameter	15 mm
Depth	9 mm		

6.7 Tin(II) chloride absorption tube, of narrow glass tubing containing approximately 10 g of solid tin(II) chloride ([5.3](#)), suitably plugged with inert wool to prevent the reagent being blown into the absorption vessel.

A U-tube is suitable. Where necessary, this is inserted in the train at the exit of the combustion tube at point X in [Figure 1](#).

If the sample is known or thought to contain chloride, e.g. in the form of sodium chloride, chlorapatite, or scapolite, the chlorine formed during combustion of the sample should be removed by passing the gas stream through solid tin(II) chloride in a suitable tube or vessel ([6.7](#)) prior to absorption and titration. If numerous samples having chloride contents >1 (mass fraction) are to be analysed, it is advisable to determine the absorption capacity of the tin(II) chloride in order to be able to judge the most suitable interval for reagent replacement. In such cases, a larger absorption vessel may be preferred.

The tin(II) chloride absorption tube should also be fitted if the chloride content of the test sample is unknown.

6.8 Cylinder, 100 ml, tall form, to hold the absorbing solution.

6.9 Bubbler, multi-hole, to reach to the bottom of the cylinder ([6.8](#)).

6.10 Burette, conforming to ISO 385, graduated in divisions of 0,05 ml.

For determination of low sulfur contents [$<0,005$ % (mass fraction)], alternative titration devices such as a piston burette or a suitable micro-syringe capable of delivering small, precise aliquots of titrant may be used.

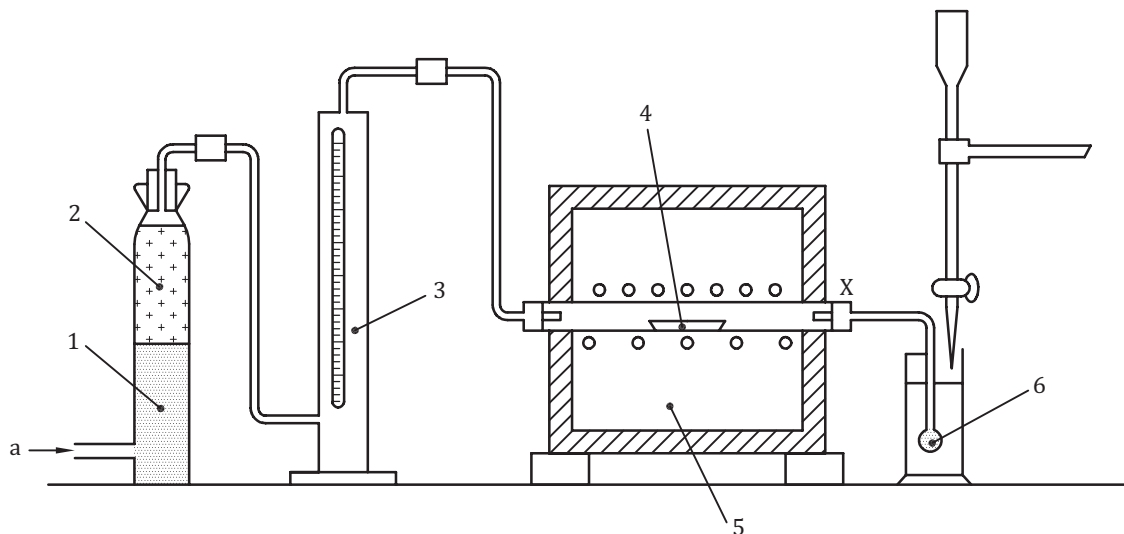

Key

- 1 sodium hydroxide coated silica
- 2 anhydrous magnesium perchlorate
- 3 flowmeter
- 4 combustion boat
- 5 resistance furnace
- 6 multihole bubbler
- a Nitrogen.

Figure 1 — Combustion apparatus

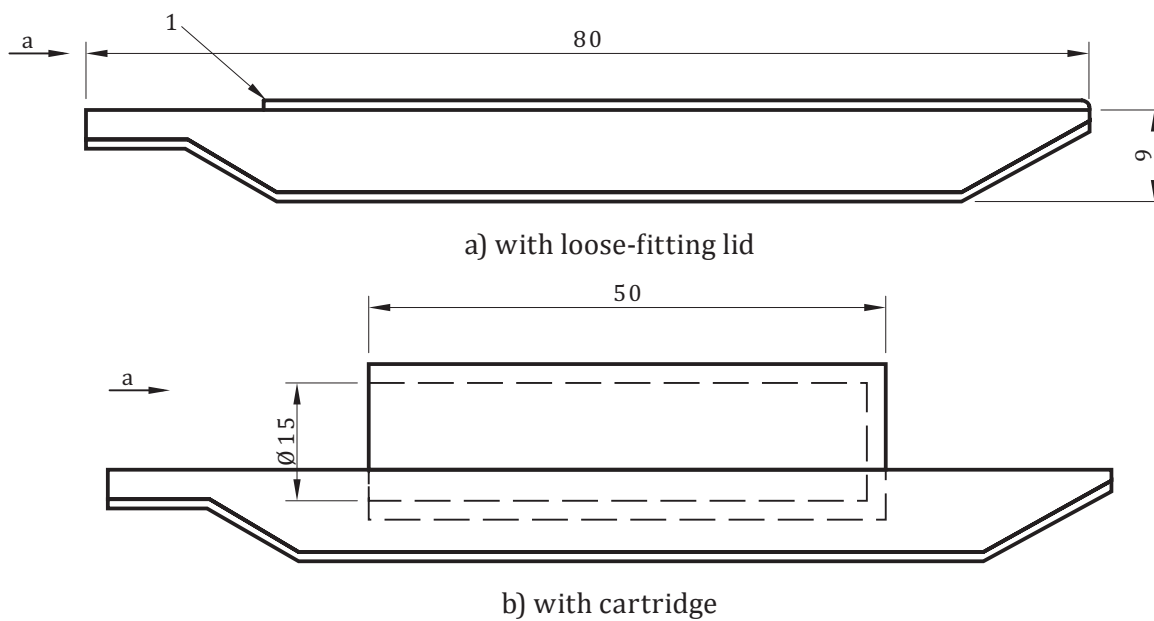

Key

- 1 loose-fitting lid
- a Gas flow.

Figure 2 — Combustion boat

7 Sampling and samples

7.1 Laboratory sample

For analysis, use a laboratory sample of $-100\ \mu\text{m}$ particle size which has been taken and prepared in accordance with ISO 3082. In the case of ores having significant contents of combined water or oxidizable compounds, use a particle size of $-160\ \mu\text{m}$.

NOTE A guideline on significant contents of combined water and oxidizable compounds is incorporated in ISO 7764.

7.2 Preparation of predried test samples

Thoroughly mix the laboratory sample and, taking multiple increments, extract a test sample in such a manner that it is representative of the entire contents of the container. Dry the test sample at $105\ \text{°C} \pm 2\ \text{°C}$ as specified in ISO 7764. This is the predried test sample.

For ores having significant content of combined water or oxidizable compounds, an air-equilibrated test sample shall be prepared in accordance with ISO 2596.

8 Procedure

8.1 Number of determinations

Carry out the analysis at least in duplicate in accordance with [Annex A](#), independently, on one predried test sample.

NOTE The expression “independently” means that the second and any subsequent result is not affected by the previous result(s). For this particular analytical method, this condition implies that the repetition of the procedure is carried out either by the same operator at a different time or by a different operator, including in either case, appropriate recalibration.

8.2 Test portion

Taking several increments, weigh, to the nearest $0,000\ 2\ \text{g}$, approximately the mass of the predried test sample specified in [Table 1](#).

For $1\ \text{g}$ of sample, the combustion boat or cartridge should accommodate the increased bulk of sample plus tungsten(VI) oxide.

The test portion should be taken and weighed quickly to avoid re-absorption of moisture.

Table 1 — Mass of test portion

Sulfur content % (mass fraction)	Mass g
0,002 to 0,100	1,0
0,100 to 0,25	0,5

8.3 Blank test and check test

In each run, one blank test and one analysis of a certified reference material of the same type of ore shall be carried out in parallel with the analysis of the ore sample(s) under the same conditions. A predried test sample of the certified reference material shall be prepared as specified in [7.2](#).

The certified reference material should be of the same type as the sample to be analysed and the properties of the two materials should be sufficiently similar to ensure that in either case no significant changes in the analytical procedure will become necessary.

Where the analysis is carried out on several samples at the same time, the blank value may be represented by one test, provided that the procedure is the same and the reagents are from the same reagent bottles.

Where the analysis is carried out on several samples of the same type of ore at the same time, the analytical value of one certified reference material may be used.

8.4 Determination

Place the test portion in a small weighing bottle containing 1,0 g of tungsten(VI) oxide (5.2) and mix thoroughly.

Transfer 80 ml of hydrochloric acid (5.5), 1 ml of potassium iodide solution (5.6), and 1 ml of starch solution (5.7) to the absorption cylinder (6.8) and place this in position at the end of the combustion train. Adjust the nitrogen flowrate to between 150 ml/min and 200 ml/min and titrate the absorbing solution with potassium iodate solution (5.8) until the colour of the solution is pale blue. Normally, a few drops of the potassium iodate solution (5.8) are sufficient.

Transfer the mixture of test portion and tungsten(VI) oxide to a refractory combustion boat fitted with a loose-fitting lid (6.6) and insert into the hot zone of the furnace (6.4) at 1 200 °C.

Alternatively, the mixture of test portion and tungsten(VI) oxide can be placed inside a porous cartridge, which is placed in a refractory combustion boat [see Figure 2 b)].

Leave the boat standing in the hot zone for approximately 1 min and then pass nitrogen at a flowrate of 150 ml/min to 200 ml/min through the furnace. With the nitrogen flowing continuously, titrate the absorbing solution with potassium iodate solution (5.8), keeping the solution just blue in colour.

Titration should be carried out during the evolution of sulfur gases in order to prevent sulfur dioxide being swept out of solution by the flow of carrier gas. It may be necessary to reduce the gas flow to 150 ml/min when titrating samples of high sulfur content. A faster flow rate of 300 ml/min may be necessary when analysing samples of very low sulfur content, to ensure complete transfer of evolved sulfur gases into the absorbing solution.

Continue to pass nitrogen through the apparatus for at least 5 min or until the absorbing solution remains permanently blue, whichever involves the longer time.

If the sample contains large amounts of combined water, a film of moisture may appear on the inside of the apparatus. This should be completely vaporized before completion of the test.

For samples of normal sulfur content, combustion times of 4 min to 8 min are usually sufficient. With samples of high sulfur content however, it may be necessary to increase combustion times to 10 min or more to ensure complete extraction of sulfur from the sample.

Wash the inside of the bubbler (6.9) several times by repeatedly releasing the inlet bung to the combustion tube (allowing the absorbant to flow back up the bubbler) and then replacing the bung to restore the nitrogen flow through the apparatus. Finally, titrate the solution to a pale blue end-point and record the volume of potassium iodate solution (5.8) used. Record also the volume of potassium iodate solution used in the blank test.

If high blanks occur [>>the equivalent of 0,001 % (mass fraction) in the test sample], this may be due to the presence of sulfur compounds either in the tungsten(VI) oxide or in the refractory boats/porous cartridges used. Tungsten(VI) oxide (5.2) can be pre-treated by heating for 2 h at a temperature of 800 °C, and the blank in the combustion boats/cartridges can be reduced by allowing them to stand overnight in a suitable furnace at a temperature of 1 200 °C and then storing in a desiccator prior to use. Such pre-treatment of tungsten(VI) oxide and the combustion boats is also required if the sulfur content of the test sample is less than 0,01 % (mass fraction).

9 Expression of results

9.1 Calculation of sulfur content

The sulfur content, w_s , is calculated as a percentage by mass, to five decimal places for contents higher than 0,01 % and to six decimal places for contents lower than 0,01 %, using [Formula \(1\)](#).

$$w_s (\%) = \frac{V_1 - V_2}{m \times 100} \quad (1)$$

where

V_1 is the volume, in millilitres, of standard potassium iodate solution ([5.8](#)) used in the titration of the test portion;

V_2 is the volume, in millilitres, of standard potassium iodate solution ([5.8](#)) used in the blank titration;

m is the mass, in grams, of the test portion.

9.2 General treatment of results

9.2.1 Repeatability and permissible tolerance

The precision of this analytical method is expressed by the following formulae:

NOTE Additional information is given in [Annexes B](#) and [C](#).

$$R_d = 0,011\,98X^{0,518\,3} \quad (2)$$

$$P = 0,114\,59X + 0,000\,85 \quad (3)$$

$$\sigma_d = 0,004\,233X^{0,518\,3} \quad (4)$$

$$\sigma_L = 0,038\,70X + 0,000\,23 \quad (5)$$

where

R_d independent duplicate limit;

P is the permissible tolerance between laboratories;

σ_d is the independent duplicate standard deviation;

σ_L is the between-laboratories standard deviation;

X is the sulfur content, expressed as a percentage by mass, of the predried test sample calculated as follows:

— within-laboratory [Formulae \(2\)](#) and [\(4\)](#): the arithmetic mean of the duplicate values;

— between-laboratories [Formulae \(3\)](#) and [\(5\)](#): the arithmetic mean of the final results ([9.2.5](#)) of the two laboratories.

9.2.2 Determination of analytical result

Having computed the independent duplicate results according to [Formula \(1\)](#), compare them with the independent duplicate limit, R_d , using the procedure given in [Annex A](#).

9.2.3 Between-laboratories precision

Between-laboratories precision is used to determine the agreement between the final results reported by two laboratories. The assumption is that both laboratories followed the same procedure described in [9.2.2](#).

Compute the following quantity:

$$\mu_{1,2} = \frac{\mu_1 + \mu_2}{2} \quad (6)$$

where

- μ_1 is final result reported by laboratory 1;
- μ_2 is the final result reported by laboratory 2;
- $\mu_{1,2}$ is the mean of final results.

If $|\mu_1 - \mu_2| \leq P$, the results are in agreement.

9.2.4 Check for trueness

The trueness of the analytical method shall be checked by applying it to a certified reference material (CRM) or a reference material (RM). The procedure is the same as that described above. After confirmation of the precision, the final laboratory result is compared with the reference or certified value, A_c . There are two possibilities:

- a) $|\mu_c - A_c| \leq C$ in which case the difference between the reported result and the reference/certified value is statistically insignificant.
- b) $|\mu_c - A_c| > C$ in which case the difference between the reported result and the reference/certified value is statistically significant.

where

- μ_c is the final result for the certified reference material;
- A_c is the reference/certified value for the CRM/RM;
- C is a value dependent on the type of CRM/RM used.

Certified reference materials used for this purpose should be prepared and certified in accordance with ISO Guide 35.

C should be calculated as follows:

$$C = 2 \sqrt{\frac{s_{Lc}^2 + \frac{s_{Wc}^2}{n_{Wc}}}{N_c} + \sigma_L^2 + \frac{\sigma_d^2}{n}} \quad (7)$$

where

- s_{Lc} is the between-laboratories standard deviation of the certifying laboratories;
- s_{Wc} is the within-laboratory standard deviation of the certifying laboratories;
- n_{Wc} is the average number of replicate determinations in the certifying laboratories;
- N_c is the number of certifying laboratories;
- n is the number of replicate determinations carried out on the CRM/RM;
- σ_L and σ_d are as defined in [9.2.1](#).

The following procedure should be used when the information on the reference material certificate is incomplete.

- If there are sufficient data to enable the between-laboratories standard deviation to be estimated, delete the expression s_{Wc}^2 / n_{Wc} and regard s_{Lc} as the standard deviation of the laboratory means;
- If the certification has been made by only one laboratory or if the interlaboratory results are missing, use the following condition:

$$C = 2 \sqrt{2 \sigma_L^2 + \frac{\sigma_d^2}{n}} \quad (8)$$

A CRM certified by only one laboratory should be avoided, unless it is known to have an unbiased certified value.

9.2.5 Calculation of final result

The final result is the arithmetic mean of the acceptable analytical values for the test sample, or as otherwise determined by the operations specified in [Annex A](#), calculated to five decimal places for contents of sulfur higher than 0,01 % (mass fraction) and to six decimal places for contents lower than 0,01 % (mass fraction). For contents higher than 0,01 % (mass fraction), the value is rounded off to the third decimal place as specified in a), b), and c). In a similar manner, with the ordinal numbers increased by one, the value for sulfur contents lower than 0,01 % (mass fraction) is rounded off to the fourth decimal place.

- a) Where the figure in the fourth decimal place is less than five, it is discarded and the figure in the third decimal place is kept unchanged.
- b) Where the figure in the fourth decimal place is five and there is a figure other than 0 in the fifth decimal place, or if the figure in the fourth decimal place is greater than five, the figure in the third decimal place is increased by one.
- c) Where the figure in the fourth decimal place is five and the figure 0 is in the fifth decimal place, the five is discarded and the figure in the third decimal place is kept unchanged, if it is 0, 2, 4, 6, or 8, and is increased by one, if it is 1, 3, 5, 7, or 9.

10 Test report

The test report shall include the following information:

- a) the name and address of the testing laboratory;
- b) the date of issue of the test report;
- c) a reference to this document, i.e. ISO 4689-2;
- d) the details necessary for the identification of the sample;

- e) the result of the analysis;
- f) the reference number of the result;
- g) any characteristics noticed during the determination, and any operations not specified in this part of ISO 4689, which may have had an influence on the result, either for the test sample or for the certified reference material(s).

Annex A (normative)

Flowsheet of the procedure for the acceptance of analytical values for test samples

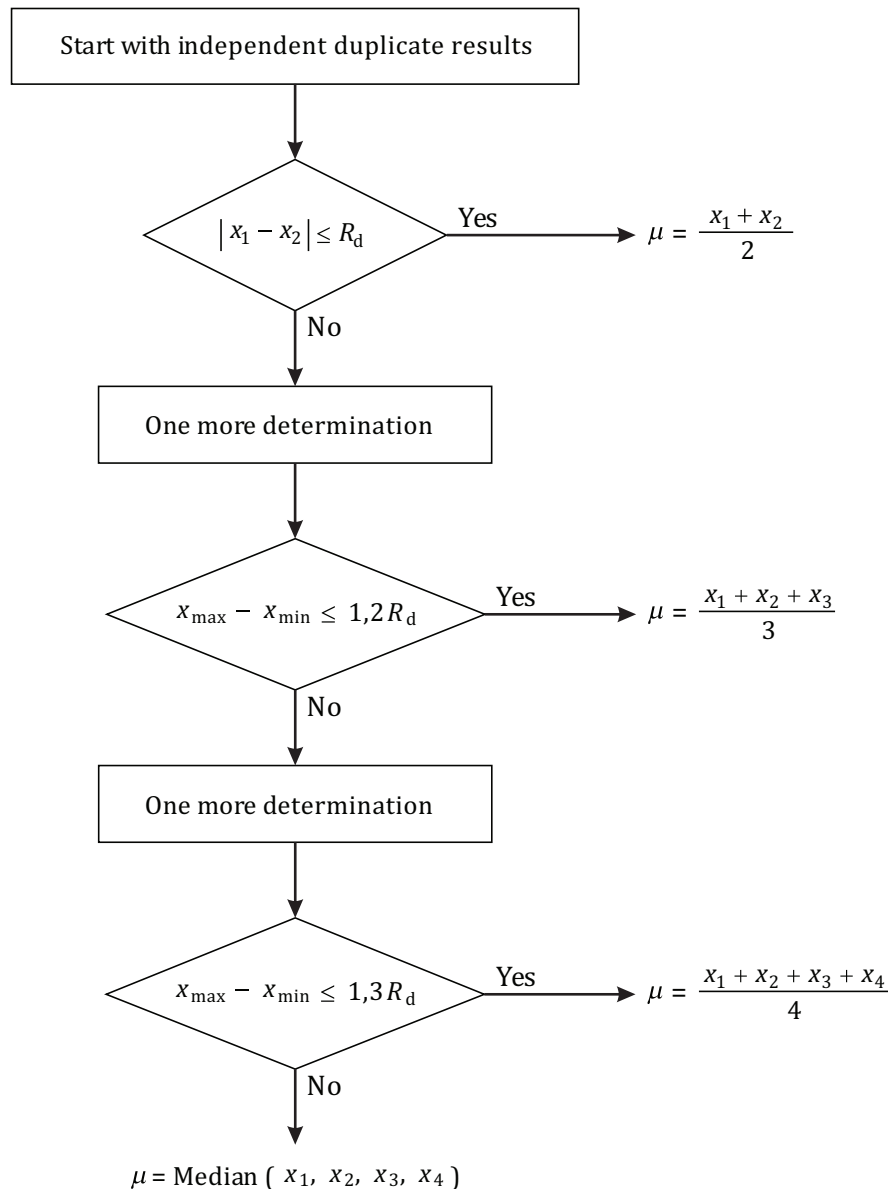

NOTE R_d is as defined in [9.2.1](#).

Figure A.1 — Flowsheet of the procedure for the acceptance of analytical values for test samples

Annex B (informative)

Derivation of repeatability and permissible tolerance equations

The regression formulae in [9.2.1](#) were derived from the results of international analytical trials carried out in 1999/2000 on seven iron ore samples, involving six laboratories in four countries.

Graphical treatment of the precision data is given in [Annex C](#).

The test samples used are listed in [Table B.1](#).

NOTE 1 Reports of the international trial and a statistical analysis of the results (Documents ISO/TC 102/SC 2 N1419 and N1422, September 2000) are available from the Secretariat of ISO/TC 102/SC 2.

NOTE 2 The statistical analysis was performed in accordance with the principles embodied in ISO 5725-2.

Table B.1 — Sulfur contents of test samples

Sample	Sulfur content
	% (mass fraction)
WG 4-5	0,004 50
WG 4-3	0,005 79
WG 4-4	0,011 8
WG 4-1	0,208
WG 4-2	0,032 7
WG 4-6	0,110
WG 4-7	0,527

Annex C (informative)

Precision data obtained by international analytical trial

Figure C.1 is a graphical presentation of the formulae in 9.2.1.

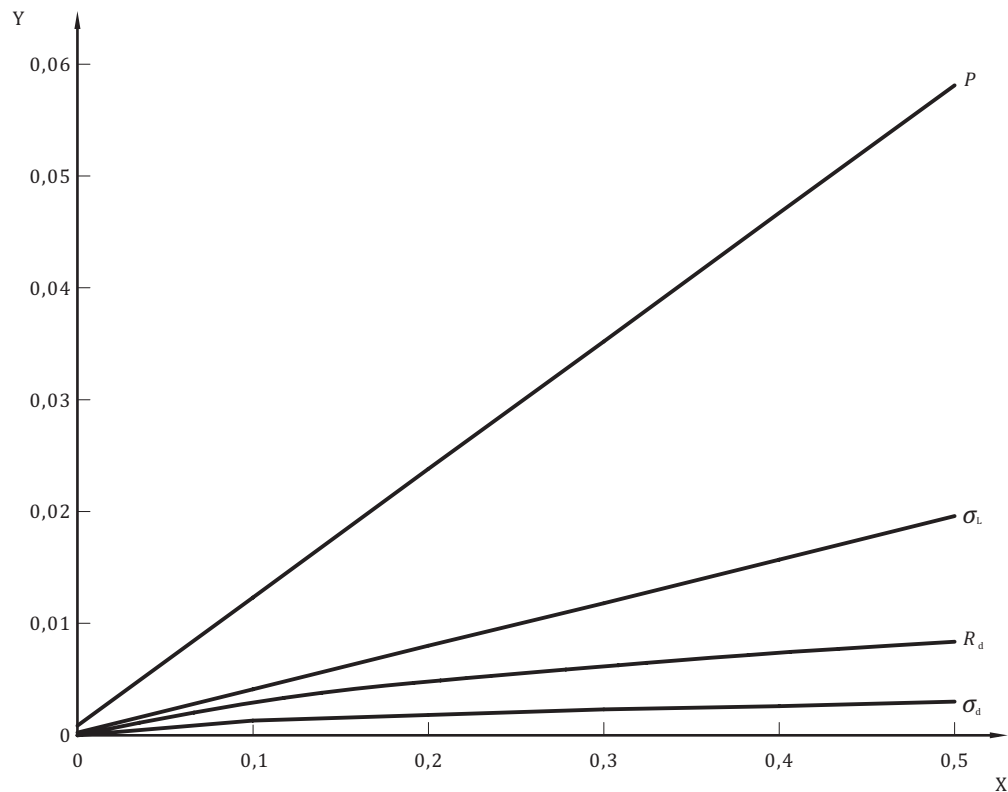

Key

X sulfur content, % mass fraction

Y precision, %

Figure C.1 — Least-squares fit of precision against X for sulfur

Bibliography

- [1] ISO 5725-2, *Accuracy (trueness and precision) of measurement methods and results — Part 2: Basic method for the determination of repeatability and reproducibility of a standard measurement method*

British Standards Institution (BSI)

BSI is the national body responsible for preparing British Standards and other standards-related publications, information and services.

BSI is incorporated by Royal Charter. British Standards and other standardization products are published by BSI Standards Limited.

About us

We bring together business, industry, government, consumers, innovators and others to shape their combined experience and expertise into standards-based solutions.

The knowledge embodied in our standards has been carefully assembled in a dependable format and refined through our open consultation process. Organizations of all sizes and across all sectors choose standards to help them achieve their goals.

Information on standards

We can provide you with the knowledge that your organization needs to succeed. Find out more about British Standards by visiting our website at bsigroup.com/standards or contacting our Customer Services team or Knowledge Centre.

Buying standards

You can buy and download PDF versions of BSI publications, including British and adopted European and international standards, through our website at bsigroup.com/shop, where hard copies can also be purchased.

If you need international and foreign standards from other Standards Development Organizations, hard copies can be ordered from our Customer Services team.

Copyright in BSI publications

All the content in BSI publications, including British Standards, is the property of and copyrighted by BSI or some person or entity that owns copyright in the information used (such as the international standardization bodies) and has formally licensed such information to BSI for commercial publication and use.

Save for the provisions below, you may not transfer, share or disseminate any portion of the standard to any other person. You may not adapt, distribute, commercially exploit, or publicly display the standard or any portion thereof in any manner whatsoever without BSI's prior written consent.

Storing and using standards

Standards purchased in soft copy format:

- A British Standard purchased in soft copy format is licensed to a sole named user for personal or internal company use only.
- The standard may be stored on more than 1 device provided that it is accessible by the sole named user only and that only 1 copy is accessed at any one time.
- A single paper copy may be printed for personal or internal company use only.

Standards purchased in hard copy format:

- A British Standard purchased in hard copy format is for personal or internal company use only.
- It may not be further reproduced – in any format – to create an additional copy. This includes scanning of the document.

If you need more than 1 copy of the document, or if you wish to share the document on an internal network, you can save money by choosing a subscription product (see 'Subscriptions').

Reproducing extracts

For permission to reproduce content from BSI publications contact the BSI Copyright & Licensing team.

Subscriptions

Our range of subscription services are designed to make using standards easier for you. For further information on our subscription products go to bsigroup.com/subscriptions.

With **British Standards Online (BSOL)** you'll have instant access to over 55,000 British and adopted European and international standards from your desktop. It's available 24/7 and is refreshed daily so you'll always be up to date.

You can keep in touch with standards developments and receive substantial discounts on the purchase price of standards, both in single copy and subscription format, by becoming a **BSI Subscribing Member**.

PLUS is an updating service exclusive to BSI Subscribing Members. You will automatically receive the latest hard copy of your standards when they're revised or replaced.

To find out more about becoming a BSI Subscribing Member and the benefits of membership, please visit bsigroup.com/shop.

With a **Multi-User Network Licence (MUNL)** you are able to host standards publications on your intranet. Licences can cover as few or as many users as you wish. With updates supplied as soon as they're available, you can be sure your documentation is current. For further information, email subscriptions@bsigroup.com.

Revisions

Our British Standards and other publications are updated by amendment or revision.

We continually improve the quality of our products and services to benefit your business. If you find an inaccuracy or ambiguity within a British Standard or other BSI publication please inform the Knowledge Centre.

Useful Contacts

Customer Services

Tel: +44 345 086 9001

Email (orders): orders@bsigroup.com

Email (enquiries): cservices@bsigroup.com

Subscriptions

Tel: +44 345 086 9001

Email: subscriptions@bsigroup.com

Knowledge Centre

Tel: +44 20 8996 7004

Email: knowledgecentre@bsigroup.com

Copyright & Licensing

Tel: +44 20 8996 7070

Email: copyright@bsigroup.com

BSI Group Headquarters

389 Chiswick High Road London W4 4AL UK