

BS ISO 4604:2011



BSI Standards Publication

Reinforcement fabrics — Determination of conventional flexural stiffness — Fixed-angle flexometer method

bsi.

...making excellence a habit.™

National foreword

This British Standard is the UK implementation of ISO 4604:2011.

The UK participation in its preparation was entrusted to Technical Committee PRI/42, Fibre reinforced thermosetting plastics and preregs.

A list of organizations represented on this committee can be obtained on request to its secretary.

This publication does not purport to include all the necessary provisions of a contract. Users are responsible for its correct application.

© BSI 2011

ISBN 978 0 580 74663 5

ICS 59.100.10

Compliance with a British Standard cannot confer immunity from legal obligations.

This British Standard was published under the authority of the Standards Policy and Strategy Committee on 31 December 2011.

Amendments issued since publication

Date	Text affected
------	---------------

**Reinforcement fabrics — Determination
of conventional flexural stiffness —
Fixed-angle flexometer method**

*Tissus de renforcement — Détermination de la rigidité conventionnelle
en flexion — Méthode du flexomètre à angle fixe*





COPYRIGHT PROTECTED DOCUMENT

© ISO 2011

All rights reserved. Unless otherwise specified, no part of this publication may be reproduced or utilized in any form or by any means, electronic or mechanical, including photocopying and microfilm, without permission in writing from either ISO at the address below or ISO's member body in the country of the requester.

ISO copyright office
Case postale 56 • CH-1211 Geneva 20
Tel. + 41 22 749 01 11
Fax + 41 22 749 09 47
E-mail copyright@iso.org
Web www.iso.org

Published in Switzerland

Foreword

ISO (the International Organization for Standardization) is a worldwide federation of national standards bodies (ISO member bodies). The work of preparing International Standards is normally carried out through ISO technical committees. Each member body interested in a subject for which a technical committee has been established has the right to be represented on that committee. International organizations, governmental and non-governmental, in liaison with ISO, also take part in the work. ISO collaborates closely with the International Electrotechnical Commission (IEC) on all matters of electrotechnical standardization.

International Standards are drafted in accordance with the rules given in the ISO/IEC Directives, Part 2.

The main task of technical committees is to prepare International Standards. Draft International Standards adopted by the technical committees are circulated to the member bodies for voting. Publication as an International Standard requires approval by at least 75 % of the member bodies casting a vote.

Attention is drawn to the possibility that some of the elements of this document may be the subject of patent rights. ISO shall not be held responsible for identifying any or all such patent rights.

ISO 4604 was prepared by Technical Committee ISO/TC 61, *Plastics*, Subcommittee SC 13, *Composites and reinforcement fibres*.

This second edition cancels and replaces the first edition (ISO 4604:1978), of which it constitutes a minor revision. The main changes are as follows:

- the scope has been broadened to cover all reinforcement fabrics (not just textile glass fabrics) and the title of the standard modified in consequence;
- the normative references clause has been updated.

Reinforcement fabrics — Determination of conventional flexural stiffness — Fixed-angle flexometer method

1 Scope

This International Standard specifies a method of determining the conventional flexural stiffness of reinforcement fabrics by means of a fixed-angle flexometer. This method is not suitable for testing fabrics that are limp or that have a marked tendency to curl or twist or fray.

2 Normative references

The following referenced documents are indispensable for the application of this document. For dated references, only the edition cited applies. For undated references, the latest edition of the referenced document (including any amendments) applies.

ISO 291, *Plastics — Standard atmospheres for conditioning and testing*

ISO 3374, *Reinforcement products — Mats and fabrics — Determination of mass per unit area*

3 Principle

A rectangular strip of fabric is supported on a horizontal platform in a direction perpendicular to one edge of the platform. The strip is moved in the direction of its length so that an increasing portion overhangs and bends down under its own weight. When the tip of the specimen has reached a plane passing through the edge of the platform and inclined at an angle of $41,5^\circ$ below the horizontal, the overhanging length is measured.

The conventional flexural stiffness is calculated from the overhanging length of the test specimen and the mass per unit area of the fabric.

NOTE This determination of the conventional flexural stiffness is based on a report published in *Shirley Institute Memoirs*, 9 (1930), p. 81, and *Journal of the Textile Institute*, 21 (1930), T380.

4 Apparatus

4.1 Fixed-angle flexometer, the essential features of which are shown in Figure 1.

On the horizontal platform P rests a slide S, graduated on its upper surface in millimetres.

The under-surface of S is covered with a layer of high-friction antistatic material such as sheet rubber, and the upper surface of P is polished so that, when S is moved, it will carry forward a specimen placed between the slide and the platform P.

The width of the slide S shall be 25 mm and the length at least 300 mm, and its mass shall be $10 \text{ g} \pm 2 \text{ g}$ per centimetre of length.

When the front edge of the slide coincides with the front edge of P, the zero of the scale on S coincides with a datum line D on the instrument. Two sighting lines, L_1 and L_2 , passing through the upper forward edge of P and inclined at an angle of $41,5^\circ$ below the horizontal, are inscribed on the transparent side-pieces of the instrument.

The range of the instrument is governed by its size. It shall allow the determination of the overhanging length of the specimen.

4.2 Cutting die, measuring 250 mm × 25 mm.

4.3 Suitable cutting device.

5 Conditioning and test atmosphere

The test specimens shall be conditioned for at least 6 h in an atmosphere chosen from those specified in ISO 291 until the mass of each specimen remains constant to within 0,25 % of its original mass when the specimen is reweighed at intervals of 2 h.

The test shall be carried out in the same atmosphere.

Dimensions in millimetres

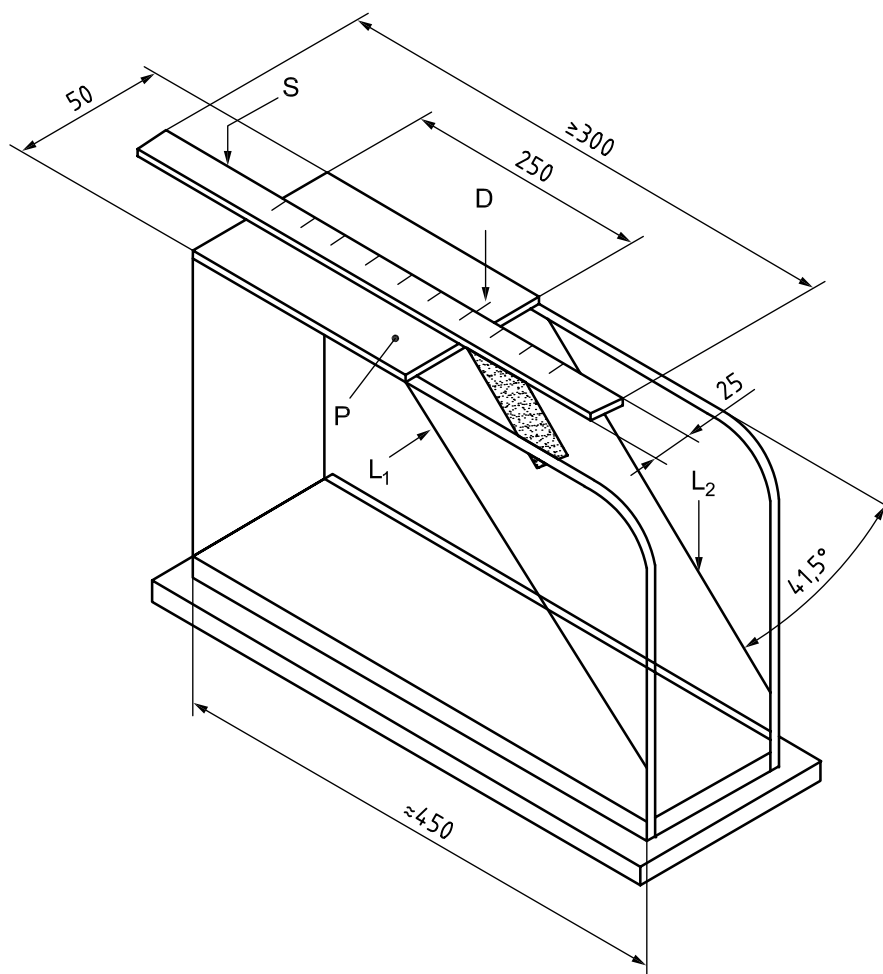

Key

- D datum line on platform
- L₁ sighting line
- L₂ sighting line
- P platform
- S side

Figure 1 — Fixed-angle flexometer for determination of stiffness

6 Test specimens

Rectangular specimens of width 25 mm and length 250 mm shall be cut from the fabrics to be tested.

Six specimens shall be taken with their long edges parallel to the direction of the warp threads (subsequently referred to as warp specimens) and six in the perpendicular direction (subsequently referred to as weft specimens). On each test specimen, identify the fabric faces.

The specimens shall be cut so that, as far as possible, no two warp specimens contain the same warp threads and no two weft specimens contain the same weft threads.

Selvages, end pieces and creased or folded places shall not be included in the specimens. The fabric and the specimens shall be handled as little as possible.

7 Procedure

7.1 Place the flexometer (4.1) on a level table. Place the test specimen on the platform P with one end coinciding with the front edge of the platform. Place the slide S on the specimen so that the zero of the scale is in line with the mark D. Push the slide slowly forward so that the specimen is made to project over the edge of P and bends down under its own weight. Continue to move the slide forward until the end of the specimen comes into line with the two lines L_1 and L_2 .

If the specimen twists, align the mid-point of the end with L_1 and L_2 .

Read the graduation on the slide S opposite the datum line D. The reading, in millimetres, is the overhanging length of the specimen.

NOTE 1 A minor readjustment of the position of the slide might have to be made immediately before this reading is taken.

NOTE 2 It will be found helpful in carrying out this procedure to place the flexometer so that the zero on the slide S lies towards the observer and at a level which enables the reading to be read with comfort. The position of the end of the specimen relative to the sighting lines can then be observed in a mirror suitably placed or attached to one side of the instrument.

7.2 Carry out the same operation with two other specimens taken in the same direction and with the same surface of the fabric upwards. Repeat with the other three specimens taken in the same direction and with the other surface of the fabric upwards.

7.3 Repeat steps 7.1 and 7.2 on the specimens taken in the other direction.

8 Expression of results

Calculate for each direction (warp or weft) of the fabric, and separately for each face, the average overhanging length l .

Using the appropriate average value, calculate the conventional flexural stiffness G separately for each face of the fabric and separately for the warp and weft directions of the fabric, using the formula

$$G = 9,81 \rho_A \left(\frac{l}{2} \right)^3$$

where

ρ_A is the mass per unit area, in grams per square metre, of the fabric, determined in accordance with ISO 3374;

l is the appropriate average overhanging length, in metres;

G is the conventional flexural stiffness, in millinewton metres, for the direction and face being considered.

9 Test report

The test report shall include the following information:

- a) a reference to this International Standard;
- b) all details necessary for complete identification of the reinforcement fabric tested, including its construction;
- c) the conditioning temperature and relative humidity chosen from ISO 291;
- d) the conditioning time, in hours, if different from that specified;
- e) the number of warp and weft specimens tested, if different from that specified;
- f) the conventional warp flexural stiffness for each face of the fabric;
- g) the conventional weft flexural stiffness for each face of the fabric;
- h) details of any operations not provided for by this International Standard and of any incidents which might have had an influence upon the results;
- i) the date of the test;
- j) any other relevant information.

ICS 59.100.10

Price based on 4 pages

British Standards Institution (BSI)

BSI is the national body responsible for preparing British Standards and other standards-related publications, information and services.

BSI is incorporated by Royal Charter. British Standards and other standardization products are published by BSI Standards Limited.

About us

We bring together business, industry, government, consumers, innovators and others to shape their combined experience and expertise into standards-based solutions.

The knowledge embodied in our standards has been carefully assembled in a dependable format and refined through our open consultation process. Organizations of all sizes and across all sectors choose standards to help them achieve their goals.

Information on standards

We can provide you with the knowledge that your organization needs to succeed. Find out more about British Standards by visiting our website at bsigroup.com/standards or contacting our Customer Services team or Knowledge Centre.

Buying standards

You can buy and download PDF versions of BSI publications, including British and adopted European and international standards, through our website at bsigroup.com/shop, where hard copies can also be purchased.

If you need international and foreign standards from other Standards Development Organizations, hard copies can be ordered from our Customer Services team.

Subscriptions

Our range of subscription services are designed to make using standards easier for you. For further information on our subscription products go to bsigroup.com/subscriptions.

With **British Standards Online (BSOL)** you'll have instant access to over 55,000 British and adopted European and international standards from your desktop. It's available 24/7 and is refreshed daily so you'll always be up to date.

You can keep in touch with standards developments and receive substantial discounts on the purchase price of standards, both in single copy and subscription format, by becoming a **BSI Subscribing Member**.

PLUS is an updating service exclusive to BSI Subscribing Members. You will automatically receive the latest hard copy of your standards when they're revised or replaced.

To find out more about becoming a BSI Subscribing Member and the benefits of membership, please visit bsigroup.com/shop.

With a **Multi-User Network Licence (MUNL)** you are able to host standards publications on your intranet. Licences can cover as few or as many users as you wish. With updates supplied as soon as they're available, you can be sure your documentation is current. For further information, email bsmusales@bsigroup.com.

BSI Group Headquarters

389 Chiswick High Road London W4 4AL UK

Revisions

Our British Standards and other publications are updated by amendment or revision.

We continually improve the quality of our products and services to benefit your business. If you find an inaccuracy or ambiguity within a British Standard or other BSI publication please inform the Knowledge Centre.

Copyright

All the data, software and documentation set out in all British Standards and other BSI publications are the property of and copyrighted by BSI, or some person or entity that owns copyright in the information used (such as the international standardization bodies) and has formally licensed such information to BSI for commercial publication and use. Except as permitted under the Copyright, Designs and Patents Act 1988 no extract may be reproduced, stored in a retrieval system or transmitted in any form or by any means – electronic, photocopying, recording or otherwise – without prior written permission from BSI. Details and advice can be obtained from the Copyright & Licensing Department.

Useful Contacts:

Customer Services

Tel: +44 845 086 9001

Email (orders): orders@bsigroup.com

Email (enquiries): cservices@bsigroup.com

Subscriptions

Tel: +44 845 086 9001

Email: subscriptions@bsigroup.com

Knowledge Centre

Tel: +44 20 8996 7004

Email: knowledgecentre@bsigroup.com

Copyright & Licensing

Tel: +44 20 8996 7070

Email: copyright@bsigroup.com



...making excellence a habit.™