

BS ISO 4437-4:2015



BSI Standards Publication

# Plastics piping systems for the supply of gaseous fuels — Polyethylene (PE)

Part 4: Valves

**bsi.**

...making excellence a habit.™

**National foreword**

This British Standard is the UK implementation of ISO 4437-4:2015.

The UK participation in its preparation was entrusted to Technical Committee PRI/88/2, Plastics piping for pressure applications.

A list of organizations represented on this committee can be obtained on request to its secretary.

This publication does not purport to include all the necessary provisions of a contract. Users are responsible for its correct application.

© The British Standards Institution 2015.  
Published by BSI Standards Limited 2015

ISBN 978 0 580 81958 2

ICS 75.200; 83.140.30

**Compliance with a British Standard cannot confer immunity from legal obligations.**

This British Standard was published under the authority of the Standards Policy and Strategy Committee on 30 April 2015.

**Amendments/corrigenda issued since publication**

Date	Text affected
------	---------------

---

INTERNATIONAL  
STANDARD

BS ISO 4437-4:2015

**ISO**  
**4437-4**

First edition  
2015-04-15

---

---

**Plastics piping systems for the supply  
of gaseous fuels — Polyethylene (PE) —**

**Part 4:  
Valves**

*Systèmes de canalisations en plastique pour la distribution des  
combustibles gazeux — Polyéthylène (PE) —*

*Partie 4: Robinets*



Reference number  
ISO 4437-4:2015(E)

© ISO 2015



**COPYRIGHT PROTECTED DOCUMENT**

© ISO 2015

All rights reserved. Unless otherwise specified, no part of this publication may be reproduced or utilized otherwise in any form or by any means, electronic or mechanical, including photocopying, or posting on the internet or an intranet, without prior written permission. Permission can be requested from either ISO at the address below or ISO's member body in the country of the requester.

ISO copyright office  
Case postale 56 • CH-1211 Geneva 20  
Tel. + 41 22 749 01 11  
Fax + 41 22 749 09 47  
E-mail [copyright@iso.org](mailto:copyright@iso.org)  
Web [www.iso.org](http://www.iso.org)

Published in Switzerland

# Contents

	Page
<b>Foreword</b> .....	<b>iv</b>
<b>Introduction</b> .....	<b>v</b>
<b>1 Scope</b> .....	<b>1</b>
<b>2 Normative references</b> .....	<b>1</b>
<b>3 Terms, definitions, symbols, and abbreviations</b> .....	<b>2</b>
3.1 General terms.....	2
3.2 Terms relating to design.....	3
<b>4 Material</b> .....	<b>3</b>
4.1 PE compound.....	3
4.2 Material for non-polyethylene parts.....	4
4.2.1 General.....	4
4.2.2 Metal parts.....	4
4.2.3 Elastomers.....	4
4.2.4 Other materials.....	4
<b>5 General characteristics</b> .....	<b>4</b>
5.1 Appearance of the valve.....	4
5.2 Colour.....	5
5.3 Design.....	5
5.3.1 General.....	5
5.3.2 Valve body.....	5
5.3.3 Operating device.....	5
5.3.4 Seals.....	5
<b>6 Geometrical characteristics</b> .....	<b>5</b>
6.1 General.....	5
6.2 Measurement of dimensions.....	6
6.3 Dimensions of spigot ends for valves.....	6
6.4 Dimensions of valves with electrofusion sockets.....	6
6.5 Dimensions of the operating device.....	6
<b>7 Mechanical characteristics of assembled valves</b> .....	<b>6</b>
7.1 General.....	6
7.2 Requirements.....	6
<b>8 Physical characteristics</b> .....	<b>10</b>
8.1 Conditioning.....	10
8.2 Requirements.....	10
<b>9 Performance requirements</b> .....	<b>11</b>
<b>10 Marking</b> .....	<b>11</b>
10.1 General.....	11
10.2 Minimum required marking.....	11
10.3 Additional marking.....	12
<b>11 Delivery conditions</b> .....	<b>12</b>
<b>Annex A (normative) Determination of the leaktightness of seat and packing</b> .....	<b>13</b>
<b>Annex B (normative) Test method for leaktightness and ease of operation after tensile loading</b> .....	<b>14</b>
<b>Bibliography</b> .....	<b>16</b>

## Foreword

ISO (the International Organization for Standardization) is a worldwide federation of national standards bodies (ISO member bodies). The work of preparing International Standards is normally carried out through ISO technical committees. Each member body interested in a subject for which a technical committee has been established has the right to be represented on that committee. International organizations, governmental and non-governmental, in liaison with ISO, also take part in the work. ISO collaborates closely with the International Electrotechnical Commission (IEC) on all matters of electrotechnical standardization.

The procedures used to develop this document and those intended for its further maintenance are described in the ISO/IEC Directives, Part 1. In particular the different approval criteria needed for the different types of ISO documents should be noted. This document was drafted in accordance with the editorial rules of the ISO/IEC Directives, Part 2 (see [www.iso.org/directives](http://www.iso.org/directives)).

Attention is drawn to the possibility that some of the elements of this document may be the subject of patent rights. ISO shall not be held responsible for identifying any or all such patent rights. Details of any patent rights identified during the development of the document will be in the Introduction and/or on the ISO list of patent declarations received (see [www.iso.org/patents](http://www.iso.org/patents)).

Any trade name used in this document is information given for the convenience of users and does not constitute an endorsement.

For an explanation on the meaning of ISO specific terms and expressions related to conformity assessment, as well as information about ISO's adherence to the WTO principles in the Technical Barriers to Trade (TBT), see the following URL: [Foreword — Supplementary information](#).

The committee responsible for this document is ISO/TC 138, *Plastics pipes, fittings and valves for the transport of fluids*, Subcommittee SC 7, *Valves and auxiliary equipment of plastics materials*.

This first edition cancels and replaces ISO 10933:1997.

ISO 4437 consists of the following parts, under the general title *Plastics piping systems for the supply of gaseous fuels — Polyethylene (PE)*:

- *Part 1: General*
- *Part 2: Pipes*
- *Part 3: Fittings*
- *Part 4: Valves*
- *Part 5: Fitness for purpose of the system*

## Introduction

Characteristics for fitness for purpose are covered in ISO 4437-5. ISO/TS 10839 gives recommended practices for installation.





# Plastics piping systems for the supply of gaseous fuels — Polyethylene (PE) —

## Part 4: Valves

### 1 Scope

This part of ISO 4437 specifies the characteristics of valves made from polyethylene (PE) for piping systems in the field of the supply of gaseous fuels.

It also specifies the test parameters for the test methods referred to in this part of ISO 4437.

In conjunction with ISO 4437-1, ISO 4437-2, ISO 4437-3:2014, and ISO 4437-5, it is applicable to PE valves, their joints, and to joints with components of PE and other materials intended to be used under the following conditions:

- a) the maximum operating pressure, MOP, is based on the design stress determined from the compound MRS divided by the C factor and taking into account RCP requirements;
- b) temperature of 20 °C as reference temperature;

NOTE 1 For other operating temperatures, derating coefficients are given in ISO 4437-5:2014.

- c) operating temperature between -20 °C and +40 °C.

This International Standard covers a range of maximum operating pressures and gives requirements concerning colours and additives.

NOTE 2 It is the responsibility of the purchaser or specifier to make the appropriate selections from these aspects, taking into account their particular requirements and any relevant national regulations and installation practices or codes.

It is applicable to bi-directional valves with spigot ends or electrofusion sockets intended to be jointed with PE pipes conforming to ISO 4437-2 without any fittings or with PE fittings conforming to ISO 4437-3:2014.

This part of ISO 4437 covers valves for pipes with a nominal outside diameter  $d_n \leq 400$  mm.

NOTE 3 Valves made from materials other than polyethylene designed for the supply of gaseous fuels conforming to the relevant standards are permitted to be used in PE piping systems according to ISO 4437 provided that they have relevant PE connections for butt fusion or electrofusion ends (see ISO 4437-3). The component, i.e. the complete valve, shall fulfil the requirements of this part of ISO 4437.

### 2 Normative references

The following documents, in whole or in part, are normatively referenced in this document and are indispensable for its application. For dated references, only the edition cited applies. For undated references, the latest edition of the referenced document (including any amendments) applies.

ISO 1133-1, *Plastics — Determination of the melt mass-flow rate (MFR) and melt volume-flow rate (MVR) of thermoplastics — Part 1: Standard method*

ISO 1167-1, *Thermoplastics pipes, fittings and assemblies for the conveyance of fluids — Determination of the resistance to internal pressure — Part 1: General method*

ISO 1167-4, *Thermoplastics pipes, fittings and assemblies for the conveyance of fluids — Determination of the resistance to internal pressure — Part 4: Preparation of assemblies*

ISO 3126, *Plastics piping systems — Plastics components — Determination of dimensions*

ISO 3127, *Thermoplastics pipes — Determination of resistance to external blows — Round-the-clock method*

ISO 4437-1, *Plastics piping systems for the supply of gaseous fuels — Polyethylene (PE) — Part 1: General*

ISO 4437-2, *Plastics piping systems for the supply of gaseous fuels — Polyethylene (PE) — Part 2: Pipes*

ISO 4437-3:2014, *Plastics piping systems for the supply of gaseous fuels — Polyethylene (PE) — Part 3: Fittings*

ISO 4437-5, *Plastics piping systems for the supply of gaseous fuels — Polyethylene (PE) — Part 5: Fitness for purpose of the system*

ISO 8233, *Thermoplastics valves — Torque — Test method*

ISO 11357-6, *Plastics — Differential scanning calorimetry (DSC) — Part 6: Determination of oxidation induction time (isothermal OIT) and oxidation induction temperature (dynamic OIT)*

ISO 12176-4, *Plastics pipes and fittings — Equipment for fusion jointing polyethylene systems — Part 4: Traceability coding*

ISO 16010, *Elastomeric seals — Material requirements for seals used in pipes and fittings carrying gaseous fuels and hydrocarbon fluids*

ISO 17778, *Plastics piping systems — Fittings, valves and ancillaries — Determination of gaseous flow rate/pressure drop relationships*

EN 736-1, *Valves — Terminology — Part 1: Definition of types of valves*

EN 736-2, *Valves — Terminology — Part 2: Definition of components of valves*

EN 1680, *Plastics piping systems — Valves for polyethylene (PE) piping systems — Test method for leaktightness under and after bending applied to the operating mechanisms*

EN 1704, *Plastics piping systems — Thermoplastics valves — Test method for the integrity of a valve after temperature cycling under bending*

EN 1705, *Plastics piping systems — Thermoplastics valves — Test method for the integrity of a valve after an external blow*

EN 12100, *Plastics piping systems — Polyethylene (PE) valves — Test method for resistance to bending between supports*

EN 12119, *Plastics piping systems — Polyethylene (PE) valves — Test method for resistance to thermal cycling*

### **3 Terms, definitions, symbols, and abbreviations**

For the purposes of this document, the terms, definitions, symbols, and abbreviations given in ISO 4437-1, EN 736-1, EN 736-2, and the following apply.

#### **3.1 General terms**

##### **3.1.1**

##### **external leaktightness**

leaktightness of the valve body enveloping the space containing the gas with respect to the atmosphere

##### **3.1.2**

##### **internal leaktightness**

leaktightness between the inlet and the outlet of the valve with the valve in the closed position

### 3.1.3

#### **leaktightness test**

test for both of the following characteristics:

- a) internal leaktightness of a valve's closing seat when closed and pressurized from either side;
- b) external leaktightness of a valve when half open

### 3.1.4

#### **initiating torque**

torque required to initiate movement of the obturator

### 3.1.5

#### **running torque**

torque required to achieve full opening or closing of the valve at maximum allowable operating pressure

### 3.1.6

#### **leakage**

emission of gas from a valve body or any component of a valve

### 3.1.7

#### **valve body**

main part of a valve which contains the obturating device (closing element, seat, packing seals, and operating stop) as applicable and provides the terminal ends for connection to the PE pipe/fittings

### 3.1.8

#### **operating device**

part of a valve for connection with the operating key which allows the opening and the closing of the valve

## 3.2 Terms relating to design

### 3.2.1

#### **full bore valve**

valve with a flow section equal to or greater than 80 % of the section corresponding to the nominal inside diameter of the body end port

[SOURCE: EN 736-3:2008]

### 3.2.2

#### **clearway valve**

valve designed to have an unobstructed flow way which allows for the passage of a theoretical sphere with a diameter that is not less than the nominal inside diameter of the body end port

[SOURCE: EN 736-3:2008]

### 3.2.3

#### **reduced bore valve**

valve with a flow section equal to or greater than 36 % of the section corresponding to the nominal inside diameter of the body end port and which does not correspond to the full bore valve

[SOURCE: EN 736-3:2008]

## 4 Material

### 4.1 PE compound

The PE compound from which the valve body with spigot ends or electrofusion sockets is made shall conform to ISO 4437-1. The stress bearing parts shall only be made from virgin material conforming to ISO 4437-1.

## 4.2 Material for non-polyethylene parts

### 4.2.1 General

All components shall conform to the relevant International Standards. Alternative standards may be applied in cases where suitable International Standards do not exist.

In all cases, fitness for purpose of the components shall be demonstrated.

The materials and the constituent elements used in making the valve (including elastomers, greases, and any metal parts, as may be used) shall be resistant to the external and internal environments as the other elements of the piping system and shall have a life expectancy under the following conditions at least equal to that of the PE pipes conforming to ISO 4437-2 with which they are intended to be used:

- a) during storage;
- b) under the effect of the gas conveyed therein;
- c) with respect to the service environment and operating conditions.

The requirements for the level of material performance of non-polyethylene parts shall be at least as stringent as that of the PE compound for the piping system. Rework materials shall not be used for stress bearing polymeric parts.

Other materials used in valves in contact with the PE pipe shall not adversely affect pipe performance or initiate stress cracking.

Metal valve bodies for PE piping systems up to 10 bar should conform to the relevant standard of ISO 153.

### 4.2.2 Metal parts

All metal parts susceptible to corrosion shall be adequately protected, provided that this is necessary for the durability and function of the system.

When dissimilar metallic materials are used which might be in contact with moisture, steps shall be taken to avoid the possibility of galvanic corrosion.

### 4.2.3 Elastomers

Elastomeric seals shall conform to ISO 16010.

Other sealing materials are permitted if proven suitable for gas service.

### 4.2.4 Other materials

Greases or lubricants shall not exude onto fusion areas and shall not affect the long-term performance of the valve materials.

Other materials conforming to [4.2.1](#) may be used provided that it is proven that the valves conform to this part of ISO 4437.

## 5 General characteristics

### 5.1 Appearance of the valve

When viewed without magnification, the internal and external surfaces of valves shall be smooth and clean and shall have no scoring, cavities, and other surface defects to an extent that would prevent conformity to this part of ISO 4437.

No component of the valve shall show any signs of damage, scratches, pitting, bubbles, blisters, inclusions, or cracks to an extent that would prevent conformity of the valves to the requirements of this part of ISO 4437.

## 5.2 Colour

The colour of the PE parts of valves shall either be black, yellow, or orange.

## 5.3 Design

### 5.3.1 General

The design of the valve shall be such that, when assembling the valve onto the pipe or other components, the electrical coils and/or seals or any other ancillary parts are not displaced.

PE valves bodies and their PE spigot ends or electrofusion sockets shall have a pressure rating of at least that of the pipe to which they are jointed.

### 5.3.2 Valve body

The valve body shall be such that it cannot be dismantled.

### 5.3.3 Operating device

The operating device shall be integral with or connected to the stem in such a way that disconnection is not possible during normal operation.

The valve shall close by turning the operating device clockwise. For a quarter-turn valve, the position of the obturator shall be clearly indicated on the top side of the operating device.

Stops shall be provided at the fully open and closed positions.

### 5.3.4 Seals

The seals, conforming to [4.2.3](#), shall be so mounted as to be resistant to normally occurring mechanical loads. Creep and cold flow effects shall be taken into account. Any mechanism that puts a loading on the seals shall be permanently locked. Line pressure shall not be used as the sole means of seal activation.

## 5.4 Appearance of factory made joints

The internal and external surfaces of the pipe and valve parts after fusion jointing, examined visually without magnification, shall be free from melt exudation outside the confines of the valve, apart from that which can be declared acceptable by the valve manufacturer or used deliberately as a fusion marker.

## 6 Geometrical characteristics

### 6.1 General

Each valve shall be characterized by its dimensions and associated end connections.

Technical data given by the manufacturer shall include at least the following information:

- a) dimensional characteristics, by working drawings;
- b) assembly instructions.

In order to prevent stress concentrations, any changes in the wall thickness of the valve body should be gradual.

## 6.2 Measurement of dimensions

Dimensions shall be measured in accordance with ISO 3126 at  $(23 \pm 2)$  °C, after being conditioned for at least 4 h. The measurement shall not be made less than 24 h after manufacture.

NOTE Indirect measurement at the stage of production is allowed at shorter time periods provided that evidence is shown of correlation.

## 6.3 Dimensions of spigot ends for valves

The dimensions of spigot ends shall conform to ISO 4437-3:2014, Table 3 up to and including  $d_n$  400 mm.

## 6.4 Dimensions of valves with electrofusion sockets

The dimensions of electrofusion sockets shall conform to ISO 4437-3:2014, Table 1 up to and including  $d_n$  400 mm.

## 6.5 Dimensions of the operating device

For a quarter-turn valve, the dimension of the operating devices shall be designed so it can be operated with a  $(50^{+0,5}_0)$  mm square socket,  $(40 \pm 2)$  mm depth.

NOTE For a non-quarter-turn operated valve, attention is drawn to the requirements specified in ISO 5210.

# 7 Mechanical characteristics of assembled valves

## 7.1 General

All tests shall be carried out on valves assembled with pipe from the same series conforming to ISO 4437-2, in accordance with the technical instructions and the extreme installation conditions of utilization described in ISO 4437-5.

NOTE The properties of an assembled valve depend on the properties of the pipes and the valve and on the conditions of their installation (i.e. geometry, temperature, type, method of conditioning, assembly, and fusion procedures).

The technical descriptions of the manufacturer shall include at least the following information:

- a) service conditions (e.g. valve temperature limits);
- b) assembly instructions;
- c) for valves with electrofusion sockets, the fusion instructions (power requirements or fusion parameters with limits).

## 7.2 Requirements

Unless otherwise specified by the applicable test method, the test pieces shall be conditioned at  $(23 \pm 2)$  °C before testing in accordance with [Table 1](#).

When tested in accordance with the test methods as specified in [Table 1](#) using the indicated parameters, the valves shall have mechanical characteristics conforming to the requirements given in [Table 1](#).

**Table 1 — Mechanical characteristics**

Characteristic	Requirements	Test parameters		Test method
		Parameter	Value	
Hydrostatic strength (20 °C, 100 h)	No failure during the test period of any test piece	Conditioning time <sup>a</sup> Number of test pieces <sup>b</sup> Type of test Circumferential (hoop) stress: PE 80 PE 100 Test period Test temperature	Shall conform to ISO 1167-1 3 Water-in-water <sup>f</sup>  10,0 MPa 12,0 MPa 100 h 20 °C	ISO 1167-1 and ISO 1167-4
Hydrostatic strength (80 °C, 165 h)	No failure during the test period of any test piece <sup>c</sup>	Conditioning time <sup>a</sup> Number of test pieces <sup>b</sup> Type of test Circumferential (hoop) stress: PE 80 PE 100 Test period Test temperature	Shall conform to ISO 1167-1 3 Water-in-water <sup>f</sup>  4,5 MPa 5,4 MPa 165 h 80 °C	ISO 1167-1 and ISO 1167-4
Hydrostatic strength (80 °C, 1 000 h)	No failure during the test period of any test piece	Conditioning time <sup>a</sup> Number of test pieces <sup>b</sup> Type of test Circumferential (hoop) stress: PE 80 PE 100 Test period Test temperature	Shall conform to ISO 1167-1 3 Water-in-water <sup>f</sup>  4,0 MPa 5,0 MPa 1 000 h 80 °C	ISO 1167-1 and ISO 1167-4
Leaktightness of seat and packing	No leakage during the test period	Test temperature Type fluid Number of test pieces <sup>b</sup> Test pressure Duration of the test	23 °C Air or nitrogen 1 25 mbar 1 h	<a href="#">Annex A</a>
Leaktightness of seat and packing	No leakage during the test period	Test temperature Type fluid Number of test pieces <sup>b</sup> Test pressure Duration of the test	23 °C Air or nitrogen 1 1,5 MOP 30 s	<a href="#">Annex A</a>
<b>SAFETY PRECAUTIONS — Safety precautions need to be taken when testing with air or nitrogen up to 1,5 MOP. For testing with air or nitrogen, a pressure of a maximum of 6 bar should be used. For MOP &gt;4 bar, testing with water should be considered and the test conditions shall be agreed upon between the manufacturer and end user.</b>				
Pressure drop	Air flow rate (value indicated by the manufacturer)	Type of test Number of test pieces <sup>b</sup> Test pressure Pressure drop for $d_n \leq 63$ mm $d_n > 63$ mm	Air 1 25 mbar  0,5 mbar 0,1 mbar	ISO 17778
Operating torqued <sup>d</sup>	Torque range: — For $d_n \leq 63$ mm 5 Nm < M ≤ 35 Nm — For 63 mm < $d_n \leq 125$ mm 10 Nm < M ≤ 70 Nm — For 125 mm < $d_n \leq 400$ mm M > 10 Nm <sup>g</sup>	Test temperatures  Number of test pieces <sup>b</sup>	-20 °C and +23 °C and +40 °C 1	ISO 8233



**Table 1** (continued)

Characteristic	Requirements	Test parameters		Test method
		Parameter	Value	
Stop resistance	a) No failure at stops, and b) No leakage at seat and packing	Test temperature Number of test pieces <sup>b</sup> Torque	-20 °C and +40 °C 1 2 times the value of the maximum measured operating torque with minimum 150 Nm, during 15 s	a) ISO 8233 followed by b) <a href="#">Annex A</a>
Actuation mechanism resistance	Maximum value: 1,5 times the value of the maximum measured operating torque (see this table)	Pressure Test temperature Number of test pieces <sup>b</sup>	6 bar 23 °C 1	ISO 8233
Resistance to bending between supports	No leakage and maximum value for operating torque (see examination of operating torque)	Load applied for: 63 mm < $d_n$ ≤ 125 mm 125 mm < $d_n$ ≤ 400 mm Number of test pieces <sup>b</sup>	3,0 kN 6,0 kN 1	EN 12100
Thermal cycling resistance $d_n > 63$ mm	No leakage and maximum value for operating torque (see examination of operating torque)	Number of test pieces <sup>b</sup>	1	EN 12119
Leaktightness under bending with thermal cycling $d_n \leq 63$ mm	No leakage	Number of cycles Temperature of cycling Number of test pieces <sup>b</sup>	50 -20 °C to +40 °C 1	EN 1704
Test method for leaktightness and ease of operation after tensile loading	No leakage and maximum value for operating torque (see examination of operating torque)	Test temperature Test pressure Number of test pieces <sup>b</sup>	23 °C 25 mbar 1	<a href="#">Annex B</a>
Leaktightness under and after bending applied to the operating mechanism	No leakage	Number of test pieces <sup>b</sup>	1	EN 1680
Impact loading resistance	No leakage and maximum value for operating torque (see examination of operating torque)	Position of test piece Drop height Mass of the striker Type of the striker  Test temperature Number of test pieces <sup>b</sup>	Vertical, see <a href="#">Figure 1</a> 2 m 2,5 kg d 90 conforming to ISO 3127  -20 °C 1	EN 1705
<b>Multiple test<sup>e</sup></b>				
1) Resistance to long-term internal pressure loading	No failure of the test piece during the test period	Conditioning time <sup>a</sup> Type of test Number of test pieces <sup>b</sup> Test pressure for: PE 80 PE 100 Test period Test temperature	Shall conform to ISO 1167-1 Water-in-water <sup>f</sup> 1  16,0 bar 20,0 bar 1 000 h 20 °C	ISO 1167-1 and ISO 1167-4

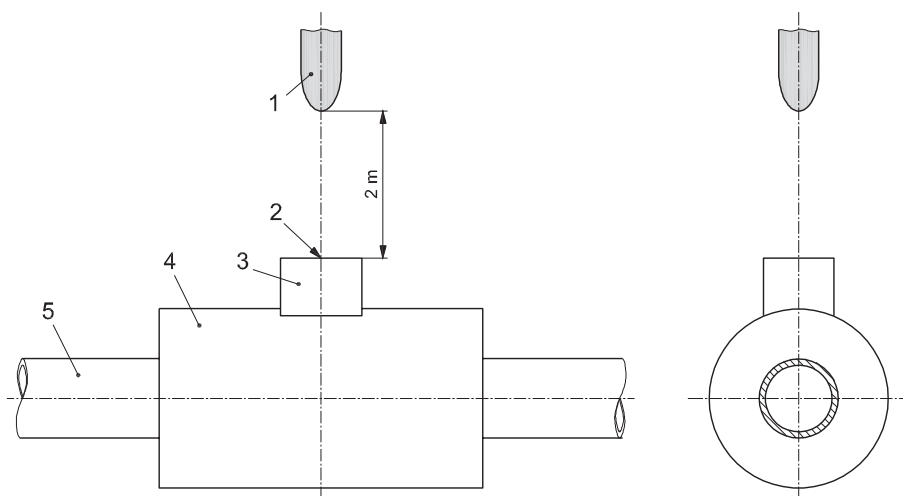

Table 1 (continued)

Characteristic	Requirements	Test parameters		Test method
		Parameter	Value	
2) Leaktightness of seat and packing	No leakage during the test period	Test temperature Type fluid Number of test pieces <sup>b</sup> Test pressure Duration of the test	23 °C Air or nitrogen 1 25 mbar 1 h	<a href="#">Annex A</a>
3) Leaktightness of seat and packing	No leakage during the test period	Test temperature Type fluid Number of test pieces <sup>b</sup> Test pressure Duration of the test	23 °C Air or nitrogen 1 1,5 MOP 30 s	<a href="#">Annex A</a>
<b>SAFETY PRECAUTIONS — Safety precautions need to be taken when testing with air or nitrogen up to 1,5 MOP. For testing with air or nitrogen a pressure of a maximum of 6 bar should be used. For MOP &gt; 4 bar, testing with water should be considered, and the test conditions shall be agreed upon between the manufacturer and end user.</b>				
4) Operating torque <sup>d</sup>	Torque range: — For $d_n \leq 63$ mm $5 \text{ Nm} < M \leq 35 \text{ Mn}$ — For $63 \text{ mm} < d_n \leq 125$ mm $10 \text{ Nm} < M \leq 70 \text{ Nm}$ — For $125 \text{ mm} < d_n \leq 400$ mm $M > 10 \text{ Nm}^g$	Test temperatures  Number of test pieces <sup>b</sup>	-20 °C and +23 °C and +40 °C  1	ISO 8233
5) Impact loading resistance	No leakage and maximum value for operating torque (see examination of operating torque)	Position of sample Drop height Mass of the striker Type of the striker Test temperature Number of test pieces <sup>b</sup>	Vertical, see <a href="#">Figure 1</a>  2 m 2,5 kg d 90 conforming to ISO 3127 -20 °C 1	EN 1705
<p><sup>a</sup> The valves shall not be pressurized within 24 h after fusion.</p> <p><sup>b</sup> The numbers of test pieces given indicate the numbers required to establish a value for the characteristic described in the table. The numbers of test pieces required for factory production control and process control should be listed in the manufacturer's quality plan. For guidance, see CEN/TS 1555-7.</p> <p><sup>c</sup> Only brittle failures shall be taken into account. If a ductile failure occurs before 165 h, the test may be repeated at a lower stress. The stress and the associated minimum test period shall be selected from <a href="#">Table 2</a> or from a line based on the stress/time points given in <a href="#">Table 2</a>.</p> <p><sup>d</sup> The initiating torque and the running torque shall be within the torque range given in this table.</p> <p><sup>e</sup> After at least 24 h after the completion of the internal pressure test, the other four tests shall be carried out on the valve in the order stated.</p> <p><sup>f</sup> Alternatively, for <math>d_n &gt; 200</math> mm, the test can also be performed in air. In case of dispute, water in water shall be used.</p> <p><sup>g</sup> The maximum torque manually applied to the gear or lever shall not exceed 250 Nm and the maximum diameter of the wheel or the length of the lever shall be less than 1 m.</p>				

**Table 2 — Circumferential (hoop) stress at 80 °C and associated minimum test period**

PE 80		PE 100	
Stress MPa	Minimum test period h	Stress MPa	Minimum test period h
4,5	165	5,4	165
4,4	233	5,3	256
4,3	331	5,2	399
4,2	474	5,1	629
4,1	685	5,0	1 000
4,0	1 000	—	—



**Key**

- 1 striker
- 2 impact point
- 3 operating device
- 4 valve body
- 5 valve outlet

**Figure 1 — Position of the test piece for the impact loading test**

## 8 Physical characteristics

### 8.1 Conditioning

Unless otherwise specified by the applicable test method, the test pieces shall be conditioned at  $(23 \pm 2)$  °C before testing in accordance with [Table 3](#).

### 8.2 Requirements

When tested in accordance with the test methods specified in [Table 3](#) using the indicated parameters, the valves shall have physical characteristics conforming to the requirements given in [Table 3](#).

**Table 3 — Physical characteristics**

Characteristic	Requirements	Test parameters		Test method
		Parameter	Value	
Oxidation induction time (thermal stability)	≥20 min	Test temperature Number of test pieces <sup>a</sup> Test environment Specimen weight	200 °C <sup>b</sup> 3 Oxygen 15 mg ± 2 mg	ISO 11357-6
Melt mass-flow rate (MFR)	After processing maximum deviation of ±20 % of the value measured on the batch used to manufacture the valve	Loading mass Test temperature Time Number of test pieces <sup>a</sup>	5 kg 190 °C 10 min Shall conform to ISO 1133-1	ISO 1133-1
<p><sup>a</sup> The number of test pieces given indicate the numbers required to establish a value for the characteristic described in the table. The number of test pieces required for factory production control and process control should be listed in the manufacturer's quality plan. For guidance, see CEN/TS 1555-7:2013.</p> <p><sup>b</sup> Test may be carried out at 210 °C or 220 °C provided that there is clear correlation to the results at 200 °C; in case of dispute, the reference temperature shall be 200 °C.</p>				

## 9 Performance requirements

When valves conforming to this part of ISO 4437 are assembled to each other or to components conforming to other parts of ISO 4437, the joints shall conform to ISO 4437-5.

## 10 Marking

### 10.1 General

**10.1.1** Unless otherwise stated in [Table 4](#), the marking elements shall be printed or formed directly on the valve in such a way that after storage, weathering, handling, and installation, legibility is maintained during use of the valve.

NOTE The manufacturer is not responsible for marking being illegible due to actions caused during installation and use such as painting, scratching, covering of the components, or using detergents, etc. on the components unless agreed upon or specified by the manufacturer.

**10.1.2** Marking shall not initiate cracks or other types of defects which adversely influence the performance of the valve.

**10.1.3** If printing is used, the colour of the printed information shall differ from the basic colour of the valve.

**10.1.4** The size of the marking shall be such that it is legible without magnification.

**10.1.5** There shall be no marking over the minimum spigot length of the valve.

### 10.2 Minimum required marking

The minimum required marking shall conform to [Table 4](#).

**Table 4 — Minimum required marking**

Aspects	Mark or symbol
Reference to this International Standard <sup>a</sup>	ISO 4437
Manufacturer's name and/or trademark	Name or symbol
Nominal outside diameter(s) of pipe, $d_n$	e.g. 110
Material and designation	e.g. PE 100
Design application series	e.g. SDR 11
Manufacturer's information <sup>b</sup>	
Intended use <sup>a</sup>	Gas
Flow direction (only for unidirectional valve)	Arrow
<sup>a</sup> This information may be printed on a label associated with the valve or on an individual bag. <sup>b</sup> For providing traceability, the following details shall be given: — production period, year, month, and/or week, in figures or in code; — name or code for the production site if the manufacturer is producing the same product at different sites.	

### 10.3 Additional marking

If traceability codes are provided, these shall be in accordance with ISO 12176-4.

## 11 Delivery conditions

The valves shall be packaged in bulk or individually protected where necessary in order to prevent deterioration and contamination. Whenever possible, they shall be placed in individual bags, cardboard boxes, or cartons.

Constituents of valve packaging shall not create contamination which can prevent normal jointing or valve operation.

NOTE It is recommended to protect the spigot end by external caps.

The cartons and/or individual bags shall bear at least one label with the manufacturer's name, type and dimensions of the part valve, number of units in the box, and any special storage conditions and storage time limits.

Valves should be stored in their original packing until ready for use.

## Annex A (normative)

### Determination of the leaktightness of seat and packing

#### A.1 General

This Annex specifies the test method to verify the leaktightness of the seat and packing of a valve/valve body made from PE.

#### A.2 Test method

Test equipment shall not subject the valve to externally applied stresses which might affect the results of the tests.

The valve shall be tested according to ISO 9393-1:2004, 7.4, maintaining an ambient test temperature of  $(23 \pm 2)$  °C.

The method of internal leakage testing shall result in the application of the full differential test pressure specified in [Table 1](#) across the seat or seats in the direction for which they are designed. Tests for typical types of valves shall be as specified in [Table A.1](#).

Any unidirectional flow valve shall be tested in the specified flow direction only. Bidirectional valve shall be tested in both flow directions.

The duration of the test shall conform to the specified values specified in [Table 1](#).

**Table A.1 — Obturator tightness test methods**

Type of valves	Test method
Gate valves Ball valves Plug valves	The body cavity shall be filled with the test fluid. Pressure shall be applied successively to each side of the closed valve and the valve shall be subsequently checked for leakage.  Valves with independent double seating (such as two-piece obturator or double-seated valves) may be tested by applying pressure between the seats and each side of the closed valve checked for leakage.
Butterfly valves Diaphragm valves	Pressure shall be applied in the most adverse direction; valves with symmetrical seating may be tested in either direction.
Check valves	Pressure shall be applied in the direction tending to close the obturator and the opposite side shall be checked for leakage.

## Annex B (normative)

### Test method for leaktightness and ease of operation after tensile loading

#### B.1 Apparatus

**B.1.1 Tensile test machine**, capable of applying to a test piece and maintaining for a specified period,  $t$ , a tensile force corresponding to a specified longitudinal tensile stress,  $\sigma_x$ , in the walls of pipes joined to the valve and then producing a specified rate of extension until the test piece yields or breaks.

**B.1.2 Grips or couplings**, to enable the test machine ([B.1.1](#)) to apply the appropriate force, directly or through intermediate fittings.

**B.1.3 Pressurising equipment**, to enable a specified internal pressure,  $p$ , to be applied via suitable connections to the test piece while it is subject to the tensile force.

#### B.2 Test piece

The test piece shall comprise the valve under test assembled in accordance with [7.1](#) between two PE pipes, each of the nominal outside diameter,  $d_n$ , and the SDR series with which the valve is designed to be used, and each pipe having a length of either  $2d_n$  mm or 250 mm, whichever is the shorter.

#### B.3 Conditions

The valves shall be tested using the following conditions:

- a) longitudinal tensile stress,  $\sigma_x$ , in the connected pipe wall shall be 12 MPa;
- b) internal pressure,  $p$ , shall be 25 mbar maintained for the specified duration of the test;
- c) period,  $t$ , for which the tensile force is maintained steady shall be 1 h;
- d) rate of extension between the grips shall be 25 mm/min  $\pm$  1 mm/min.

#### B.4 Procedure

**B.4.1** The valve shall be tested by closing the obturator in the normal manner while maintaining an ambient test temperature of  $(23 \pm 2)$  °C. Mount the test piece in the tensile testing machine and apply the specified internal pressure,  $p$ , for leaktightness assessment before tensile testing. In case of bi-directional valves, apply pressure to both sides. Ensure that all relevant parts of the valve are subject to the pressure.

**B.4.2** Apply an increasing force smoothly until the applicable longitudinal stress,  $\sigma_x$ , is induced in the walls of the pipes in the test assembly.

**B.4.3** Maintain the force for the specified length of time,  $t$ , and then close the pressure inlet and check the leaktightness for 30 s.

**B.4.4** Remove the tensile load and, without any intervening operation of the valve, submit the valve to torque testing in accordance with ISO 8233 and leaktightness testing in accordance with [Annex A](#) and record the results obtained.

## **B.5 Test report**

The test report shall include the following information:

- a) full identification of the valve under test;
- b) reference to this method of test, i.e. ISO 4437-4, Annex B;
- c) dimensions of the pipes used in the test piece;
- d) longitudinal tensile stress,  $\sigma_x$ ;
- e) tensile force applied to the test piece;
- f) internal pressure,  $p$ , applied to the test piece;
- g) period,  $t$ , for which the tensile force was maintained;
- h) results of torque testing in accordance with ISO 8233;
- i) results of leaktightness testing in accordance with [Annex A](#);
- j) any conditions or incidents not detailed by this test method and which might have affected the results;
- k) date of testing.

## Bibliography

- [1] ISO/TS 10839, *Polyethylene pipes and fittings for the supply of gaseous fuels — Code of practice for design, handling and installation*
- [2] EN 736-3:2008, *Valves — Terminology — Part 3: Definition of terms*
- [3] ISO 5210, *Industrial valves — Multi-turn valve actuator attachments*
- [4] CEN/TS 1555-7, *Plastics piping systems for the supply of gaseous fuels — Polyethylene (PE) — Part 7: Guidance for the assessment of conformity*









# British Standards Institution (BSI)

BSI is the national body responsible for preparing British Standards and other standards-related publications, information and services.

BSI is incorporated by Royal Charter. British Standards and other standardization products are published by BSI Standards Limited.

## About us

We bring together business, industry, government, consumers, innovators and others to shape their combined experience and expertise into standards-based solutions.

The knowledge embodied in our standards has been carefully assembled in a dependable format and refined through our open consultation process. Organizations of all sizes and across all sectors choose standards to help them achieve their goals.

## Information on standards

We can provide you with the knowledge that your organization needs to succeed. Find out more about British Standards by visiting our website at [bsigroup.com/standards](http://bsigroup.com/standards) or contacting our Customer Services team or Knowledge Centre.

## Buying standards

You can buy and download PDF versions of BSI publications, including British and adopted European and international standards, through our website at [bsigroup.com/shop](http://bsigroup.com/shop), where hard copies can also be purchased.

If you need international and foreign standards from other Standards Development Organizations, hard copies can be ordered from our Customer Services team.

## Subscriptions

Our range of subscription services are designed to make using standards easier for you. For further information on our subscription products go to [bsigroup.com/subscriptions](http://bsigroup.com/subscriptions).

With **British Standards Online (BSOL)** you'll have instant access to over 55,000 British and adopted European and international standards from your desktop. It's available 24/7 and is refreshed daily so you'll always be up to date.

You can keep in touch with standards developments and receive substantial discounts on the purchase price of standards, both in single copy and subscription format, by becoming a **BSI Subscribing Member**.

**PLUS** is an updating service exclusive to BSI Subscribing Members. You will automatically receive the latest hard copy of your standards when they're revised or replaced.

To find out more about becoming a BSI Subscribing Member and the benefits of membership, please visit [bsigroup.com/shop](http://bsigroup.com/shop).

With a **Multi-User Network Licence (MUNL)** you are able to host standards publications on your intranet. Licences can cover as few or as many users as you wish. With updates supplied as soon as they're available, you can be sure your documentation is current. For further information, email [bsmusales@bsigroup.com](mailto:bsmusales@bsigroup.com).

## BSI Group Headquarters

389 Chiswick High Road London W4 4AL UK

## Revisions

Our British Standards and other publications are updated by amendment or revision.

We continually improve the quality of our products and services to benefit your business. If you find an inaccuracy or ambiguity within a British Standard or other BSI publication please inform the Knowledge Centre.

## Copyright

All the data, software and documentation set out in all British Standards and other BSI publications are the property of and copyrighted by BSI, or some person or entity that owns copyright in the information used (such as the international standardization bodies) and has formally licensed such information to BSI for commercial publication and use. Except as permitted under the Copyright, Designs and Patents Act 1988 no extract may be reproduced, stored in a retrieval system or transmitted in any form or by any means – electronic, photocopying, recording or otherwise – without prior written permission from BSI. Details and advice can be obtained from the Copyright & Licensing Department.

## Useful Contacts:

### Customer Services

**Tel:** +44 845 086 9001

**Email (orders):** [orders@bsigroup.com](mailto:orders@bsigroup.com)

**Email (enquiries):** [cservices@bsigroup.com](mailto:cservices@bsigroup.com)

### Subscriptions

**Tel:** +44 845 086 9001

**Email:** [subscriptions@bsigroup.com](mailto:subscriptions@bsigroup.com)

### Knowledge Centre

**Tel:** +44 20 8996 7004

**Email:** [knowledgecentre@bsigroup.com](mailto:knowledgecentre@bsigroup.com)

### Copyright & Licensing

**Tel:** +44 20 8996 7070

**Email:** [copyright@bsigroup.com](mailto:copyright@bsigroup.com)



...making excellence a habit.™