

Hydraulic fluid power — Fluid contamination — Determination of particulate contamination by the counting method using an optical microscope

ICS 23.100.60

National foreword

This British Standard reproduces verbatim ISO 4407:2002 and implements it as the UK national standard. It supersedes BS 5540-8:1991 which is withdrawn.

The UK participation in its preparation was entrusted by Technical Committee MCE/18, Fluid power systems and components, to Subcommittee MCE/18/-/6, Contamination control, which has the responsibility to:

- aid enquirers to understand the text;
- present to the responsible international/European committee any enquiries on the interpretation, or proposals for change, and keep the UK interests informed;
- monitor related international and European developments and promulgate them in the UK.

A list of organizations represented on this subcommittee can be obtained on request to its secretary.

Cross-references

The British Standards which implement international or European publications referred to in this document may be found in the BSI Standards Catalogue under the section entitled “International Standards Correspondence Index”, or by using the “Find” facility of the BSI Standards Electronic Catalogue.

A British Standard does not purport to include all the necessary provisions of a contract. Users of British Standards are responsible for their correct application.

Compliance with a British Standard does not of itself confer immunity from legal obligations.

Summary of pages

This document comprises a front cover, an inside front cover, the ISO title page, pages ii to v, a blank page, pages 1 to 14, an inside back cover and a back cover.

The BSI copyright date displayed in this document indicates when the document was last issued.

Amendments issued since publication

Amd. No.	Date	Comments

This British Standard, having been prepared under the direction of the Engineering Sector Policy and Strategy Committee, was published under the authority of the Standards Policy and Strategy Committee on 21 May 2002

© BSI 21 May 2002

ISBN 0 580 39724 6

INTERNATIONAL STANDARD

ISO 4407

Second edition
2002-04-15

Hydraulic fluid power — Fluid contamination — Determination of particulate contamination by the counting method using an optical microscope

*Transmissions hydrauliques — Pollution des fluides — Détermination de la
pollution particulaire par comptage au microscope optique*



Reference number
ISO 4407:2002(E)

Contents		Page
Foreword		iv
Introduction		v
1 Scope		1
2 Normative references		1
3 Terms and definitions		2
4 Counting principle		4
5 Apparatus		4
6 Reagent and chemicals		6
6.1 Reagent and rinsing and cleaning chemicals		6
6.2 Liquids for transparentizing the membrane filter (transmitted-light method)		6
7 Glassware cleaning procedure		6
8 Calibration procedures		6
8.1 Microscope calibration		6
8.2 Determination of Effective Filtration Area (EFA)		7
9 Membrane filter preparation		7
9.1 Sample preparation		7
9.2 Blank analysis		8
9.3 Separation of contaminants by vacuum filtration		8
9.4 Evaluation of suitability for counting		9
9.5 Mounting of membrane filters for observation under transmitted light		10
10 Particle sizing and counting procedure		10
10.1 Particle sizing		10
10.2 Selection of nominal magnification		10
10.3 Statistical counting procedure		10
10.4 Calculation of total count		11
10.5 Verification of data		12
11 Expression of results		13
12 Identification statement (Reference to this International Standard)		13
Bibliography		14

Foreword

ISO (the International Organization for Standardization) is a worldwide federation of national standards bodies (ISO member bodies). The work of preparing International Standards is normally carried out through ISO technical committees. Each member body interested in a subject for which a technical committee has been established has the right to be represented on that committee. International organizations, governmental and non-governmental, in liaison with ISO, also take part in the work. ISO collaborates closely with the International Electrotechnical Commission (IEC) on all matters of electrotechnical standardization.

International Standards are drafted in accordance with the rules given in the ISO/IEC Directives, Part 3.

The main task of technical committees is to prepare International Standards. Draft International Standards adopted by the technical committees are circulated to the member bodies for voting. Publication as an International Standard requires approval by at least 75 % of the member bodies casting a vote.

Attention is drawn to the possibility that some of the elements of this International Standard may be the subject of patent rights. ISO shall not be held responsible for identifying any or all such patent rights.

ISO 4407 was prepared by Technical Committee ISO/TC 131, *Fluid power systems*, Subcommittee SC 6, *Contamination control and hydraulic fluids*.

This second edition cancels and replaces the first edition (ISO 4407:1991), which has been technically revised.

Introduction

In hydraulic fluid power systems, power is transmitted and controlled through a liquid under pressure within an enclosed circuit. The liquid is both a lubricant and power transmitting medium.

The presence of particulate contamination in the liquid interferes with its ability to lubricate and causes wear to the components. The level of contamination in the liquid has a direct bearing on the performance and reliability of the system, and should be controlled to a level appropriate for the system concerned.

Quantitative determination of particulate contamination requires precision in obtaining a representative sample of the liquid and in determining the level of contamination. The method of particle counting using the optical microscope is an accepted means of determining the extent of contamination. The accuracy of particle count data can be affected by the techniques used.

This International Standard details procedures for the separation of particles in liquid samples by vacuum filtration and subsequent analysis of the particles deposited on an analytical membrane filter by microscopic techniques. The techniques involve counting using transmitted or incident light both manually and using image analysis techniques. This International Standard specifies methods to ensure accurate and consistent results.

Hydraulic fluid power — Fluid contamination — Determination of particulate contamination by the counting method using an optical microscope

WARNING — The use of this International Standard may involve hazardous materials, operations and equipment. This International Standard does not purport to address all the safety problems associated with its use. It is the responsibility of the user of this International Standard to establish appropriate safety and health practices and determine the applicability of regulative limitations prior to use.

1 Scope

This International Standard specifies methods for determining the level of particulate contamination in liquids used in hydraulic systems by counting the number of particles deposited on the surface of a membrane filter using an optical microscope. It includes particle counting by two manual methods and image analysis, using either transmitted or incident lighting systems.

Particle sizes $\geq 2 \mu\text{m}$ can be sized and counted by this method, but the resolution and accuracy of the results will depend upon the optical system used and the capabilities of the operator.

All hydraulic fluids with a wide range of contamination levels can be analysed according to this International Standard. However, the counting uncertainty at the larger particle sizes increases if the volume filtered is reduced to allow smaller sized particles to be counted, where a fine precipitate or a high particle concentration is present.

2 Normative references

The following normative documents contain provisions which, through reference in this text, constitute provisions of this International Standard. For dated references, subsequent amendments to, or revisions of, any of these publications do not apply. However, parties to agreements based on this International Standard are encouraged to investigate the possibility of applying the most recent editions of the normative documents indicated below. For undated references, the latest edition of the normative document referred to applies. Members of ISO and IEC maintain registers of currently valid International Standards.

ISO 3722, *Hydraulic fluid power — Fluid sample containers — Qualifying and controlling cleaning methods*

ISO 4406:1999, *Hydraulic fluid power — Fluids — Method for coding the level of contamination by solid particles*

ISO 4788, *Laboratory glassware — Graduated measuring cylinders*

ISO 5598, *Fluid power systems and components — Vocabulary*

ISO 14644-1:1999, *Cleanrooms and associated controlled environments — Classification of air cleanliness*

3 Terms and definitions

For the purposes of this International Standard, the definitions given in ISO 5598 and the following apply.

3.1

blank count

count resulting from contaminants introduced from other sources, such as reagents, cleaning of glassware and preparation of the membrane filter (see 9.2)

3.2

calculation factor

ratio of the effective filtration area to the total area counted

3.3

effective filtration area

EFA

circular area of the membrane filter open to flow during filtration of liquid

NOTE Both the effective filtration area (EFA) and the effective filtration diameter (EFD) are determined in 8.2.

3.4

fibre

particle longer than 100 µm with a length-to-width ratio greater than or equal to 10:1

3.5

fixative liquid

liquid that, as a result of a heat curing process, causes a membrane filter to adhere to a glass base slide, resulting in an opaque residue

3.6

grid square

square with sides of nominally 3,1 mm printed on membrane filters

NOTE Gridded membrane filters may not be suitable for counting using image analysis techniques.

3.7

image analyser

instrumentation to automatically size and count particles deposited on a membrane filter

NOTE A video image of the particle is digitally recreated based upon the difference in the grey scale contrast of the particle and background, and the size is automatically computed. Sizing of the particle can also be undertaken on the video screen.

3.8

mountant liquid

liquid that, when heated, causes a membrane filter, previously treated with fixative liquid, to become transparent and to adhere to the cover slip (see 5.7)

3.9

particle size

size of particle as defined by the particle's longest dimension

3.10

solvent

liquid that is physically and chemically compatible with and miscible in the sample liquid

NOTE A solvent is used for diluting the sample liquid, and can be used for cleaning and rinsing the apparatus. The solvent should be chemically compatible with the apparatus, especially the membrane filter, and should not dissolve the particles.

3.11**statistical counting**

counting and sizing particles using a proportion of the membrane filter's surface, whereby at least 150 particles are counted over a total of at least 10 separate locations (fields)

NOTE 1 Statistical counting requires an even distribution of particles over the complete surface, and membrane filters should be rejected for counting if this is not achieved.

NOTE 2 Counting 150 particles gives a counting uncertainty of 8 %, and the counting uncertainty will be reduced if more particles are counted.

3.12**unit area**

proportion of membrane filter that is counted for statistical purposes

NOTE For manual counting, the unit area is defined as the area of the membrane filter bound in the horizontal plane by two adjacent vertical membrane filter grid lines and in the vertical plane by two parallel lines either on the ocular micrometer eyepiece or drawn on a projection screen. Examples are given in Figure 1. For image analysis, this is a fixed field of view defined by the optical and electronic systems.

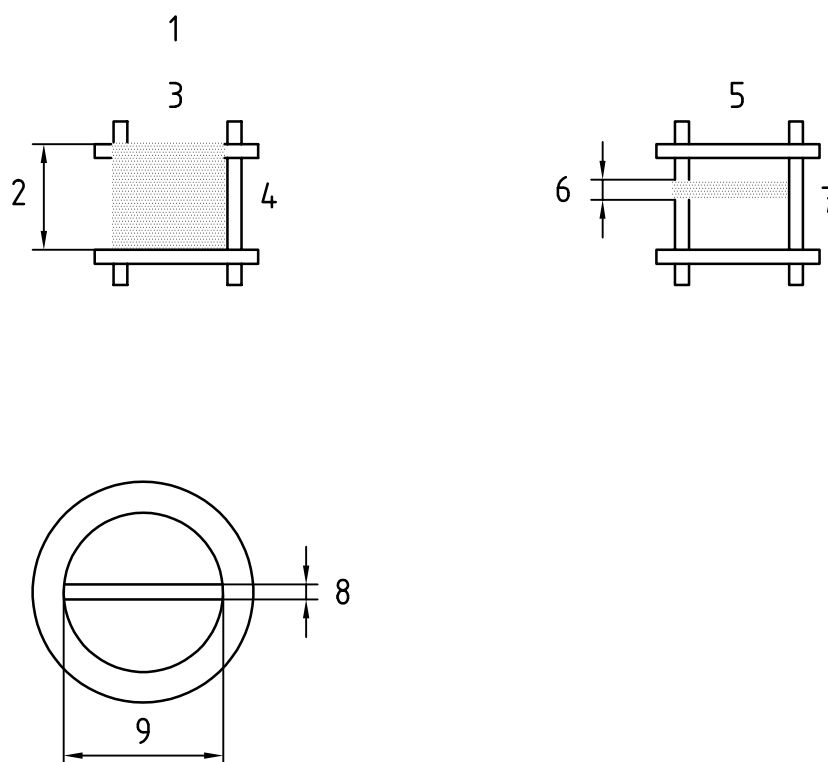
**Key**

- 1 Grid square
- 2 Width of grid square (mm)
- 3 Length of grid square (mm)
- 4 Full grid square
- 5 Unit area on a gridded membrane
- 6 Graticule height used for defining unit area (μm)
- 7 Unit area
- 8 Diametric unit area on ungridded membrane
- 9 Effective filtration diameter of membrane

Figure 1 — Examples of unit areas

4 Counting principle

A known volume of hydraulic liquid is vacuum filtered through a membrane filter to separate the contaminants from the liquid. The particles are examined microscopically using either incident light or transmitted light, after making the membrane filter transparent, to size and count the contaminant particles according to their largest dimension.

5 Apparatus

5.1 Drying oven, able to control temperature up to $(70 \pm 2) ^\circ\text{C}$.

5.2 External lamp, of variable intensity, where oblique illumination of the specimen stage is required.

5.3 Filter holder, comprising:

- a funnel, 300 mL capacity with suitable calibrated volumetric graduations [e.g. (25 ± 2) mL];
- a suitable cover for the funnel (e.g. a Petri dish);
- a clamping device;
- a suitable base to support the membrane filter;
- a means of dissipating any static electricity generated during the filtering process.

5.4 Graduated cylinders, for measuring out the volume of test liquid. Either the accuracy should conform to ISO 4788 or a sample bottle calibrated with suitable volumetric graduations can be used. The accuracy of graduation should be $\pm 2\%$.

5.5 Image analysing equipment, comprising a microscope base with a range of objective lenses and trinocular head for attaching a video camera connected to a suitable video monitor. The output of the video camera is fed to a computer which recreates a video digital image of the view, where the particles are sized and counted using specially developed software.

Although a manual X-Y stage and focus can be used, it is recommended that these be motorized and controlled by the software as this enables the particles to be localized.

5.6 Membrane filters, compatible with the sample liquid and any solvents or chemicals used in the processes. Normally, the membrane filter shall be of 47 mm diameter, white, gridded (each grid square with sides $3,08 \text{ mm} \pm 0,05 \text{ mm}$ and an area equal to 1/100th of the effective filtration area), with a pore size less than $1,5 \mu\text{m}$, used for manual counting down to $2 \mu\text{m}$. A 47 mm diameter, white, ungridded membrane filter with a pore size less than $1,5 \mu\text{m}$ is recommended for image analysis. Membrane filters of different diameters are permissible.

It is permissible to use membrane filters of different nominal pore size to account for the minimum size of particle to be counted and the condition of the sample liquid. The pore size of the membrane filter should have a particle removal efficiency of 99,9 % at the minimum size to be counted.

The colour of the membrane filter shall be chosen for maximum contrast with the particulate contamination to be observed. For example, if most of the contaminant is translucent, transparent or white, a black membrane filter should be considered.

5.7 Microscope glass base slides and microscope glass cover slips, for transmitted-light method only, with dimensions greater than the diameter of the membrane filter. The thickness of the cover slip should be selected to ensure that the particles are in focus at the magnification used.

5.8 Membrane filter holder, plastic or equivalent with lid, for retaining the membrane filter (incident-light method only).

5.9 Microscope for particle counting, with a range of objective lenses that, in combination with the ocular lenses, are able to resolve particles $\geq 2 \mu\text{m}$. The microscope shall be equipped with:

- fine and coarse focus control;
- through-the-lens lighting for the incident light method and/or a bottom lighting source for the transmitted light method;
- a mechanical stage so that the effective filtration area of the membrane filter can be scanned;
- provision on the mechanical stage for securely holding the membrane filter holder or glass slide;
- an ocular micrometer of which the smallest division shall not subtend a distance larger than the smallest particle to be counted at a particular magnification, and with suitable graduations.

For counting with transmitted light, the optimum equipment is a projector microscope with suitable screen, over-eyepiece mirror and rotating superstage.

NOTE 1 For image analysis, it is preferable to have a stabilized lighting source controlled by the imaging software so that illumination fluctuations are eliminated and automatic correction is made for any intensity drift in the lighting source.

NOTE 2 For accurate characterization of particles using the incident light method, an additional oblique lighting source may be required (see 5.2).

Nominal magnification and optical combinations for manual counting are given in Table 1.

NOTE 3 The manufacturer of the image analysis equipment should be contacted for the magnification provided by the trinocular head video/camera combination.

Table 1 — Nominal magnifications and optical combinations

Magnification (nominal)	Ocular lens	Objective lens	Suggested minimum particle size μm
$\times 50$	$\times 10$	$\times 5$	20
$\times 100$	$\times 10$	$\times 10$	10
$\times 200$	$\times 10$	$\times 20$	5
$\times 500$	$\times 10$	$\times 50$	2

5.10 Plastic film, 0,05 mm thick $\times 50 \text{ mm} \times 50 \text{ mm}$, placed between the cap and neck of the sample bottle if the cap does not have an internal seal. The film shall be compatible with both the cleaning and sample liquids.

5.11 Sample bottles, 250 mL nominal capacity, preferably flat-bottomed and wide-mouthed with a screw cap containing a suitable internal polymeric seal.

5.12 Sampling agitating device, suitable for redispersing the contaminant in the liquid sample. The device, such as a laboratory bottle roller, a three-axis paint shaker or an ultrasonic bath rated at $3\,000 \text{ W/m}^2$ to $10\,000 \text{ W/m}^2$ of base area, shall not alter the basic size distribution of the contaminant.

5.13 Solvent dispenser, a pressurized vessel that discharges solvent (see 6.1.4) through an in-line membrane filter with a pore size not greater than $1 \mu\text{m}$.

5.14 Stage micrometer, graduated in 0,1 mm and 0,01 mm divisions, calibrated and traceable to national standards.

5.15 Tally counter, with sufficient sections to accumulate the numbers of particles and fields counted.

5.16 Tweezers, flat-bladed, blunt tips, of stainless steel.

5.17 Vacuum device, able to establish a vacuum of 86,6 kPa (\approx 0,87 bar, 650 mm Hg).

5.18 Vacuum flask, suitable for the filter holder, and of a capacity able to filter the entire volume of sample liquid without refilling.

6 Reagent and chemicals

6.1 Reagent and rinsing and cleaning chemicals

6.1.1 Propan-2-ol [isopropyl alcohol (IPA)].

6.1.2 Liquid detergent, without solid residue.

6.1.3 Distilled or demineralized water.

6.1.4 Solvent, for rinsing equipment and dilution samples.

Petroleum spirit (boiling point 100 °C to 120 °C) or similar is suitable if the sample liquid is a petroleum-based or synthetic oil; alternatively distilled or demineralized water is used if the sample liquid is water-based. The solvent shall be physically and chemically compatible with the sample liquid and apparatus.

WARNING — Exercise care when using solvents with low flash points as there could be an explosion risk. Appropriate precautions should be taken to avoid inhalation of fumes from these solvents. Always use suitable protective equipment. Attention is drawn to local health and safety procedures.

6.2 Liquids for transparentizing the membrane filter (transmitted-light method)

6.2.1 Fixative liquid, see 3.5.

6.2.2 Mountant liquid, see 3.8, with a refractive index similar to that of the glass cover slip.

7 Glassware cleaning procedure

7.1 Clean and validate the cleanliness level of the filtration apparatus, graduated cylinders (5.4), bottles (5.11), glass slides and cover slips (5.7) and membrane filter holders (5.8) in accordance with ISO 3722. The final liquid used for the flush should be either filtered petroleum spirit (or similar solvent) for petroleum based or synthetic oils, propan-2-ol or demineralized water for water-based liquids.

7.2 The required cleanliness level (RCL) of the apparatus should be such that contaminant cannot significantly contribute to the overall result. An RCL of less than 250 particles greater than 5 μm per 100 mL of bottle volume is suitable for sample bottles.

All liquids used for cleaning and rinsing shall be filtered through a 1 μm or finer membrane filter.

8 Calibration procedures

8.1 Microscope calibration

8.1.1 Calibration should be carried out at least annually or whenever any major adjustment or change is made to the optics. The stage micrometer (5.14) should be calibrated every five years.

8.1.2 For microscopes used for manual counting, select a magnification on the microscope and place the stage micrometer on the microscope stage so that the image of the graticule is superimposed upon and aligned with the eyepiece or trinocular graticule. Ensure that the scale and graticule are in focus.

8.1.3 Compare the two superimposed scales and align the lowest numbered division on the eyepiece graticule so that it is coincident with one division on the stage micrometer and so that the highest graticule division falls within the divisions of the stage micrometer. Select a suitable number of eyepiece divisions (e.g. 50) and determine the number of corresponding divisions on the stage micrometer. Determine the length scale of the graticule divisions at the magnification used.

8.1.4 Repeat 8.1.2 and 8.1.3 for all magnifications and record the data in a suitable calibration recording system.

8.1.5 A similar procedure to 8.1.3 shall be carried out for image analysing equipment but the individual method may vary from instrument to instrument. Carry out the calibration in accordance with the manufacturer's instructions.

8.2 Determination of Effective Filtration Area (EFA)

8.2.1 This procedure should be performed before a new vacuum funnel is used for the first time, and should be recalibrated every five years.

8.2.2 Make up a suspension of suitable staining contaminant which will identify the effective filtration area of the membrane filter when filtered. Red oxide contaminant is suitable for this. Prepare by dispersing into a suitable volume of solvent to give a concentration of approximately 1 mg/L and shake vigorously or mix by ultrasonics for 1 min.

8.2.3 Assemble a 1 µm filter membrane filter in the vacuum apparatus to be calibrated and clamp firmly. Vacuum filter about 25 mL or sufficient volume of suspension to clearly stain the membrane filter, and aspirate to dryness.

8.2.4 Unclamp, remove the membrane filter and measure the diameter [effective filtration diameter (EFD)] of the stain in at least two planes to within 0,1 mm. Average the result and calculate the effective filtration area (EFA). Mark the funnel with a suitable code and record the result in a suitable calibration recording system.

9 Membrane filter preparation

9.1 Sample preparation

9.1.1 After noting all sample identification details, remove any tied-up or loosely attached labels ensuring that sample identity is retained. Thoroughly clean the outside of the sample bottle, particularly around the cap, by washing with filtered solvent dispensed from the pressurized dispenser. Take care not to force contaminant into the cap area.

9.1.2 If the sample has been standing for a period of time, particle settlement, and hence agglomeration, will occur. It is essential that the agglomerates are broken up, and the contaminant particles are re-dispersed evenly within the contents of the sample before analysis.

9.1.3 Redistribute the contaminants within the contents of the bottle by either hand shaking the sample vigorously for at least 1 min, or by using an acceptable method of mixing such as a three-axis paint shaker for at least 5 min. The method chosen should not alter the original distribution of the contaminant.

9.1.4 If ultrasonics is used to break up any agglomerates, stand the sample container so that the level of the liquid in the bath is either just below the fluid level in the sample bottle, or 3/4 up the side of the container, whichever is least. The period of immersion shall not exceed 1 min. Hand shake for 30 s afterwards.

9.2 Blank analysis

9.2.1 A blank analysis should be performed before each sample analysis, unless it can be demonstrated that acceptable blanks can be consistently obtained. If so, a blank analysis should be performed before starting a counting programme and at least once during it.

9.2.2 Proceed as in 9.3, using solvent instead of sample liquid. Dispense a 100 mL volume of filtered solvent into the vacuum apparatus fitted with the selected membrane filter, vacuum filter and aspirate to dryness.

9.2.3 Perform size analysis as specified in 10.3 at $\geq 5 \mu\text{m}$. If the count at $\geq 5 \mu\text{m}$ exceeds the count levels given in the note below, this indicates insufficient cleaning. Clean the apparatus again and repeat 9.2.2 to 9.2.3.

NOTE A blank count less than 10 % of the resulting count should be achieved and larger analysis volumes of sample should be filtered if this is exceeded. A blank count of less than 100 particles sized $\geq 5 \mu\text{m}$ in 100 mL of solvent is recommended.

9.2.4 If high blank counts occur after recleaning, all processes should be investigated, i.e. cleaning procedure, filtration of solvent, the preparation procedure and the environment.

9.2.5 Record the blank count on a worksheet (see Figure 2).

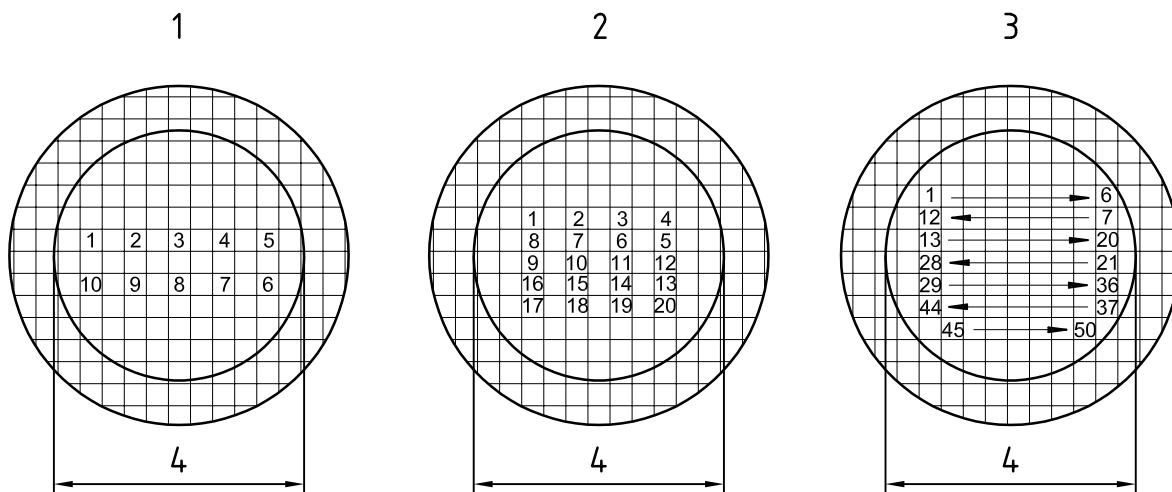

Key

- 1 10 squares
- 2 20 squares
- 3 50 squares
- 4 Effective filtration diameter of membrane

Figure 2 — Example of counting pattern for 10, 20 and 50 locations

9.3 Separation of contaminants by vacuum filtration

9.3.1 Carry out the preparation procedure in accordance with 9.1 and within a controlled environment. A level of ISO class 5 or better in accordance with ISO 14644-1:1999 is considered appropriate.

9.3.2 Ensure that all apparatus is cleaned to the required cleanliness standard.

9.3.3 Flush the tweezers with filtered solvent, remove the selected membrane filter from its container, carefully rinse the upper surface with filtered solvent and then place the membrane filter centrally on the membrane filter holder.

As a precaution, rinse the inside of the funnel with filtered solvent, then carefully lower the funnel onto the filter without sliding. Secure the clamping device and attach the anti-static lead. Cap the funnel and do not remove until ready to start the filtration. Connect the vacuum device to the side arm of the flask.

9.3.4 Redistribute the contaminant as specified in 9.1.3 and pour the required volume from the sample bottle into either a graduated cylinder, the calibrated sample bottle, or directly into the calibrated funnel. If the sample is not transferred directly, pour the sample liquid into the filtration funnel after measurement and flush any residual sample liquid into the funnel using filtered solvent. Multiple rinses may be required. Cap the funnel and apply a vacuum.

9.3.5 When the funnel contents have been reduced to a small volume (e.g. 20 mL), stop and release the vacuum. Rinse down the funnel walls with a spirally directed jet of filtered solvent, taking care not to disturb the particles on the surface of the membrane filter. Add sufficient solvent to the funnel to completely flush the sample liquid from the membrane filter. Replace the funnel cover, vacuum filter, and aspirate to dryness.

9.3.6 With cleaned tweezers, extract the membrane filter from the vacuum apparatus and carefully place onto a clean membrane filter holder with the gridlines parallel to the edges of the slide. Cover against ingress of contamination. Mark the holder for identification.

9.3.7 With some water-based sample liquids, the membrane filter might not be dried by aspiration and could require oven drying. If so, the membrane filter should be protected from contamination by a suitable cover that allows any moisture to be released into the environment, and placed in a non-recirculatory drying oven regulated to 55 °C to 60 °C for at least 1 h. If the membrane filters show evidence of residual sample liquid, the procedures specified in 9.3.2 to 9.3.6 should be repeated rather than risk disturbing the contaminant settled on the membrane filter.

9.4 Evaluation of suitability for counting

9.4.1 Prepare a membrane filter using (100 ± 5) mL of the sample liquid in accordance with 9.3. View the membrane filter at × 50 magnification using incident lighting and examine the surface for an even distribution of particles over the whole of the effective filtration area.

NOTE It may be necessary to view the membrane filter at × 100 or × 200 for the presence of overlapping or touching particles that could be sized as a single larger particle.

9.4.2 If an even distribution of contaminant is obtained without overlapping particles, count the number of particles in accordance with clause 10. Reject the membrane filter if an uneven distribution is observed and prepare another.

9.4.3 If overlapping particles are observed, estimate the particle populations at $\geq 5 \mu\text{m}$ and calculate the volume of sample liquid to be filtered that ensures adequate separation of particles for accurate counting. Repeat the procedure specified in 9.3 with the new volume and note the volume filtered on the worksheet.

9.4.4 If the membrane filter approaches blockage before 100 mL is filtered, pour out surplus liquid from the funnel with vacuum still applied, rinse the internal surfaces of the funnel, vacuum filter, and aspirate to dryness. Inspect the membrane filter with a microscope with incident light to establish the cause of blockage.

9.4.4.1 If blockage is due to a high density of particles, estimate the reduced volume required to give an adequate separation of particles and repeat the procedure specified in 9.3. Note the volume filtered on the work sheet.

9.4.4.2 If blockage is due to a finely divided precipitate, use a coarser membrane filter and/or a reduced volume as appropriate, and repeat the procedure specified in 9.3. Note the volume filtered and the membrane filter pore size on the work sheet.

NOTE 1 If a coarser membrane filter is used, the collection efficiency at the smaller sizes may be decreased.

NOTE 2 If a coarser membrane filter is used, the smallest size at which counting is performed may have to be increased. As a guide, the minimum size should be 1,5 times the mean pore size.

9.4.5 When the filtration volume and/or membrane filter pore size is optimized, either count using incident light (clause 10) or prepare the membrane filter for counting by transmitted light (9.5).

9.5 Mounting of membrane filters for observation under transmitted light

9.5.1 Take a clean glass base slide, flush with filtered solvent and apply sufficient fixative liquid to saturate the membrane.

9.5.2 With the tweezers, carefully remove the membrane filter from the filtration equipment or membrane filter holder and place onto the fixative liquid on the glass base slide with the contaminated surface uppermost. Align the grid on the membrane filter so that it is parallel with the edge of the glass slide. Mark the slide with a reference for identification.

9.5.3 Cover the glass base slide and membrane filter to protect from contamination while heating and cooling, and place in a non-recirculatory drying oven regulated to 55 °C to 60 °C. Allow to dry for approximately 1 h. When the membrane filter becomes fixed to the glass slide, it should be opaque and white.

9.5.4 When dry, remove the base slide and cover from the oven and allow to cool and equalize to ambient temperature for 2 min to 3 min. When cooled, take a glass cover slip, flush the contact side with filtered solvent, dry, and immediately apply mountant liquid onto the cleaned surface.

9.5.5 Remove the cover from the base slide, take the slide on which the membrane filter is bonded, and lower the cover slip carrying the mountant fluid onto the membrane filter so that air is excluded. Ensure that the sides of both glasses are aligned and allow the upper cover slip to settle.

NOTE Care should be taken to avoid crushing particles under the cover slip.

9.5.6 Carefully return the assembled slide to the oven, cover, and heat for at least 90 min at 55 °C to 60 °C.

NOTE A long heating period (up to 36 h) is desirable as this improves the permanency of the mount.

9.5.7 When the drying period is completed, remove the assembled microscope slide and cover from the oven and allow to cool to ambient temperature.

10 Particle sizing and counting procedure

10.1 Particle sizing

Classify the particles in the required size intervals. The sizes selected will depend upon individual requirements but should include some or all of the following sizes: $\geq 2 \mu\text{m}$, $\geq 5 \mu\text{m}$, $\geq 15 \mu\text{m}$, $\geq 25 \mu\text{m}$, $\geq 50 \mu\text{m}$ and $\geq 100 \mu\text{m}$ to conform to the various contamination coding systems. If the data are required in size ranges, the differential counts shall be computed following final calculation of the cumulative counts.

Fibres (see 3.4) shall be included in the count for the $\geq 100 \mu\text{m}$ size and identified separately.

10.2 Selection of nominal magnification

Select the magnification appropriate to the size range to be counted in accordance with Table 1.

10.3 Statistical counting procedure

10.3.1 After preparation of the membrane filter, place the membrane filter holder with lid removed (for incident light) or the prepared slide (for transmitted light) on the microscope stage and focus on the surface of the membrane filter or a grid line. If oblique lighting is used, adjust the angle and intensity to obtain maximum particle definition.

10.3.2 For image analysis, set up the illumination, acquisition parameters and shading correction in accordance with the manufacturer's instructions.

10.3.3 Select an area of the membrane filter and a magnification commensurate with the largest size to be counted (see Table 1). Scan the first unit area and count the number of particles greater than or equal to the selected size in accordance with the sizing criterion (3.9).

NOTE The largest size should be counted first in order to minimize the effects of particle drop out and, hence, to obtain a more representative count.

10.3.4 Estimate the total particle count for the membrane filter and select a unit area conforming to the statistical counting criteria specified in 3.11.

10.3.5 Select another region of the membrane filter and count another unit area. Count all particles including fibres which are identified separately. Continue selecting separate regions of the membrane filter to either a set pattern (see Figure 3 for a suggested counting pattern) or randomly selected areas, and count the number of particles at the selected size until a minimum of 150 particles are counted over a total of at least 10 separate locations (fields). Record the numbers of particles and fields counted on a data sheet.

NOTE 1 The selected unit areas should be distributed over the effective filtration area of the membrane filter, not all from the same region.

NOTE 2 If a particle lies on the upper or left boundary grid line of a counting area, count the particle as within the boundaries of the counting area. Do not count particles on the lower or right hand boundary lines of the counting area.

NOTE 3 If there are very low concentrations of particles on the membrane filter and insufficient particles are counted in 10 separate locations, continue counting other locations until the number of particles achieves the counting criteria.

NOTE 4 Fibres (see 3.4) should be included in the count for the $\geq 100 \mu\text{m}$ size and identified separately in the data sheet.

10.3.6 Select magnifications for other sizes and repeat 10.3.1 to 10.3.5 as appropriate.

10.4 Calculation of total count

The count, N , per 100 mL greater than the selected size is given by:

$$N = \frac{A \times n \times 10^5}{f \times L \times W \times V} \text{ per 100 mL}$$

where

A is the effective filtration area (EFA) for the membrane filter (mm^2);

n is the number of particles counted greater than the selected size;

f is the number of unit areas counted;

10^5 is the factor to normalize the units used;

L is the length of unit area (mm), either the size of grid square or the diametric length;

W is the width of the unit area (μm);

V is the volume of sample liquid filtered (mL).

Sample identification:		Microscope serial no.:				Analyst:			
Effective filtration diameter of membrane filter: (mm)		Effective filtration area of membrane filter: (mm ²)				Membrane filter pore size (µm)			
Length of unit area, <i>L</i> : (mm)		Sample volume, <i>V</i> (mL)				Lighting method: (transmitted/incident)			
Particle size (µm)		Fibres (see Note 1)
Blank	No. of particles counted, <i>n</i>
	No. of unit areas counted, <i>f</i>
	Width of unit area, <i>W</i> (µm)
	Particle count, <i>N</i> (see Note 2)
Sample	No. of particles counted, <i>n</i>
	No. of unit areas counted, <i>f</i>
	Width of unit area, <i>W</i> (µm)
	Particle count per 100 mL, <i>N</i> (see Note 2)
Comments:									
Date of analysis:					Signature:				

NOTE 1 Fibres are defined as particles ≥ 100 µm in size with an aspect ratio greater than 10.

NOTE 2 Particle count is calculated from the formula:
$$N = \frac{A \times n \times 10^5}{f \times L \times W \times V}$$
 per 100 mL

Figure 3 — Example of a microscope particle count data sheet

10.5 Verification of data

It is essential that the data are checked for validity before issuing the report. This can be carried out by inspecting the data and ensuring that the numbers of particles decrease progressively with increasing size, or by plotting the data on a contamination graph [Log *N* by (Log *d*)²], as specified in Figure A.1 of ISO 4406:1999, and checking for either a sudden decrease in numbers of particles with increased size or very little change in counts at increasing size. Both may indicate errors due to an uneven distribution on the membrane filter. If so, the data should be checked for calculation errors and, if valid, the membrane filter recounted at the specific size or sizes.

11 Expression of results

Record all measurements and test details on a worksheet, and report the following minimum information:

- a) the sample designation;
- b) the number of particles per 100 mL in the sample at the sizes counted;
- c) the number of particles per 100 mL counted in the blank analysis;
- d) the effective filtration diameter and pore size of the membrane filter;
- e) the counting technique (manual or image analysis) and type of lighting used (incident or transmitted);
- f) the volume analysed (mL);
- g) any other comments.

12 Identification statement (Reference to this International Standard)

Manufacturers are strongly recommended to use the following statement in test reports, catalogues and sales literature when electing to comply with this International Standard:

“Determination of solid particles contamination by the counting method using a microscope under transmitted/incident light in accordance with ISO 4407:2002, Hydraulic fluid power — Fluid contamination — Determination of particulate contamination by the counting method using an optical microscope.”

Bibliography

- [1] ISO 4021:1992, *Hydraulic fluid power — Particulate contamination analysis — Extraction of fluid samples from lines of an operating system*

BSI — British Standards Institution

BSI is the independent national body responsible for preparing British Standards. It presents the UK view on standards in Europe and at the international level. It is incorporated by Royal Charter.

Revisions

British Standards are updated by amendment or revision. Users of British Standards should make sure that they possess the latest amendments or editions.

It is the constant aim of BSI to improve the quality of our products and services. We would be grateful if anyone finding an inaccuracy or ambiguity while using this British Standard would inform the Secretary of the technical committee responsible, the identity of which can be found on the inside front cover.
Tel: +44 (0)20 8996 9000. Fax: +44 (0)20 8996 7400.

BSI offers members an individual updating service called PLUS which ensures that subscribers automatically receive the latest editions of standards.

Buying standards

Orders for all BSI, international and foreign standards publications should be addressed to Customer Services. Tel: +44 (0)20 8996 9001.
Fax: +44 (0)20 8996 7001. Email: orders@bsi-global.com. Standards are also available from the BSI website at <http://www.bsi-global.com>.

In response to orders for international standards, it is BSI policy to supply the BSI implementation of those that have been published as British Standards, unless otherwise requested.

Information on standards

BSI provides a wide range of information on national, European and international standards through its Library and its Technical Help to Exporters Service. Various BSI electronic information services are also available which give details on all its products and services. Contact the Information Centre.
Tel: +44 (0)20 8996 7111. Fax: +44 (0)20 8996 7048. Email: info@bsi-global.com.

Subscribing members of BSI are kept up to date with standards developments and receive substantial discounts on the purchase price of standards. For details of these and other benefits contact Membership Administration.
Tel: +44 (0)20 8996 7002. Fax: +44 (0)20 8996 7001.
Email: membership@bsi-global.com.

Information regarding online access to British Standards via British Standards Online can be found at <http://www.bsi-global.com/bsonline>.

Further information about BSI is available on the BSI website at <http://www.bsi-global.com>.

Copyright

Copyright subsists in all BSI publications. BSI also holds the copyright, in the UK, of the publications of the international standardization bodies. Except as permitted under the Copyright, Designs and Patents Act 1988 no extract may be reproduced, stored in a retrieval system or transmitted in any form or by any means – electronic, photocopying, recording or otherwise – without prior written permission from BSI.

This does not preclude the free use, in the course of implementing the standard, of necessary details such as symbols, and size, type or grade designations. If these details are to be used for any other purpose than implementation then the prior written permission of BSI must be obtained.

Details and advice can be obtained from the Copyright & Licensing Manager.
Tel: +44 (0)20 8996 7070. Fax: +44 (0)20 8996 7553.
Email: copyright@bsi-global.com.