

# Liquid flow in open channels — Sediment in streams and canals — Determination of concentration, particle size distribution and relative density

ICS 17.120.20

## National foreword

This British Standard reproduces verbatim ISO 4365:2005 and implements it as the UK national standard. It supersedes BS 3680-10D:1986 which is withdrawn.

The UK participation in its preparation was entrusted to Technical Committee CPI/113, Hydrometry, which has the responsibility to:

- aid enquirers to understand the text;
- present to the responsible international/European committee any enquiries on the interpretation, or proposals for change, and keep the UK interests informed;
- monitor related international and European developments and promulgate them in the UK.

A list of organizations represented on this committee can be obtained on request to its secretary.

### Cross-references

The British Standards which implement international publications referred to in this document may be found in the *BSI Catalogue* under the section entitled “International Standards Correspondence Index”, or by using the “Search” facility of the *BSI Electronic Catalogue* or of British Standards Online.

This publication does not purport to include all the necessary provisions of a contract. Users are responsible for its correct application.

**Compliance with a British Standard does not of itself confer immunity from legal obligations.**

### Summary of pages

This document comprises a front cover, an inside front cover, the ISO title page, pages ii to v, a blank page, pages 1 to 47 and a back cover.

The BSI copyright notice displayed in this document indicates when the document was last issued.

### Amendments issued since publication

Amd. No.	Date	Comments

This British Standard was published under the authority of the Standards Policy and Strategy Committee on 23 March 2005

© BSI 23 March 2005

ISBN 0 580 45657 9

INTERNATIONAL  
STANDARD

ISO  
4365

Second edition  
2005-02-01

---

---

**Liquid flow in open channels — Sediment  
in streams and canals — Determination  
of concentration, particle size distribution  
and relative density**

*Mesure de débit des liquides dans les canaux découverts — Sédiments  
dans les cours d'eau et dans les canaux — Détermination de la  
concentration, de la distribution granulométrique et de la densité  
relative*



Reference number  
ISO 4365:2005(E)



# Contents

Page

Foreword.....	iv
Introduction .....	v
1 Scope.....	1
2 Normative references .....	1
3 Terms and definitions.....	1
4 Units of measurement .....	2
5 Properties of sediment .....	2
5.1 General.....	2
5.2 Properties of individual particles .....	2
5.3 Bulk characteristics .....	3
6 Sampling .....	3
7 Suspended sediment concentration .....	3
7.1 Methods for determining the suspended sediment concentration .....	3
7.2 Expression of concentration .....	4
8 Particle-size analysis .....	5
8.1 Particle-size analysis of suspended sediment .....	5
8.2 Particle size analysis of bed load and bed material .....	5
8.3 Expression of the particle-size distribution .....	6
9 Determination of relative density .....	8
10 Determination of particle-size distribution characteristics .....	8
11 Data processing .....	8
<b>Annex A (normative) Determination of the concentration of suspended sediment by the evaporation method (for coarse sediment particles).....</b>	<b>9</b>
<b>Annex B (normative) Determination of the concentration of suspended sediment by the filtration method using filter paper.....</b>	<b>11</b>
<b>Annex C (normative) Determination of the concentration of suspended sediment by the filtration method using gooch or other crucibles .....</b>	<b>13</b>
<b>Annex D (normative) Determination of the particle-size distribution of suspended sediment.....</b>	<b>15</b>
<b>Annex E (normative) Determination of the particle-size distribution of bed-load and bed material .....</b>	<b>19</b>
<b>Annex F (normative) Determination of the relative density of sediment.....</b>	<b>43</b>
<b>Annex G (normative) Determination of the particle-size distribution characteristics.....</b>	<b>44</b>
<b>Bibliography .....</b>	<b>47</b>

## Foreword

ISO (the International Organization for Standardization) is a worldwide federation of national standards bodies (ISO member bodies). The work of preparing International Standards is normally carried out through ISO technical committees. Each member body interested in a subject for which a technical committee has been established has the right to be represented on that committee. International organizations, governmental and non-governmental, in liaison with ISO, also take part in the work. ISO collaborates closely with the International Electrotechnical Commission (IEC) on all matters of electrotechnical standardization.

International Standards are drafted in accordance with the rules given in the ISO/IEC Directives, Part 2.

The main task of technical committees is to prepare International Standards. Draft International Standards adopted by the technical committees are circulated to the member bodies for voting. Publication as an International Standard requires approval by at least 75 % of the member bodies casting a vote.

Attention is drawn to the possibility that some of the elements of this document may be the subject of patent rights. ISO shall not be held responsible for identifying any or all such patent rights.

ISO 4365 was prepared by Technical Committee ISO/TC 113, *Hydrometry*, Subcommittee SC 6, *Sediment transport*.

This second edition cancels and replaces the first edition (ISO 4365:1985), which has been technically revised.

## **Introduction**

In dealing with problems of sedimentation and sediment transport, knowledge of the concentration and the characteristics of the sediment, such as particle size distribution and relative density, is of great importance. For this purpose, sediment samples are collected by suitable samplers and analysed in a laboratory. The results of the analysis are used in the calculation of sediment load, mean diameter and other characteristics.



# Liquid flow in open channels — Sediment in streams and canals — Determination of concentration, particle size distribution and relative density

## 1 Scope

This International Standard specifies methods for determining the concentration, particle-size distribution and relative density of sediment in streams and canals.

NOTE The detailed methods of analysis are set out in the annexes. Annexes A, B and C deal with the determination of the suspended sediment concentration by evaporation and filtration. Annexes D and E deal with the particle-size analysis of suspended sediment and outline the procedures for the bed-load and bed material sediment, respectively. Annex F deals with the determination of the relative density of sediment and Annex G with the determination of particle size distribution characteristics.

## 2 Normative references

The following referenced documents are indispensable for the application of this document. For dated references, only the edition cited applies. For undated references, the latest edition of the referenced document (including any amendments) applies.

ISO 772, *Hydrometric determinations — Vocabulary and symbols*

ISO 4363, *Measurement of liquid flow in open channels — Methods for measurement of characteristics of suspended sediment*

ISO 4364, *Measurement of liquid flow in open channels — Bed material sampling*

## 3 Terms and definitions

For the purpose of this document, the terms and definitions given in ISO 772 and the following apply.

### 3.1

#### **bed-load**

sediment in almost continuous contact with the bed, carried forward by rolling, sliding or hopping

### 3.2

#### **bed material**

sediment of which the stream bed is composed

### 3.3

#### **bed material load**

that part of the total sediment transported consisting of the bed material whose rate of movement is governed by the transporting capacity of the channel

### 3.4

#### **nominal diameter**

diameter of a sphere of the same volume as the given particle

**3.5**  
**projected diameter**  
diameter of the smallest circle that encloses the projected image of a particle when viewed in the plane of maximum stability

**3.6**  
**sediment concentration**  
ratio of the mass or volume of dry sediment in a water-sediment mixture to the total mass or volume of the suspension

NOTE When reporting, it is necessary to mention whether mass concentration or volume concentration is reported.

**3.7**  
**sedimentation diameter**  
diameter of a sphere having the same relative density and terminal settling velocity as a given particle in the same sedimentation fluid

**3.8**  
**sieve diameter**  
width of a square opening through which the given particles will just pass

**3.9**  
**relative density**  
ratio of the mass of a given volume of sediment to the mass of an equal volume of water

**3.10**  
**suspended load**  
that part of the total sediment transported which is maintained in suspension by turbulence in the flowing water for considerable periods of time without contact with the streambed

NOTE The sediment moves practically with the same velocity as that of the flowing water. It is generally expressed as a mass or volume per unit of time.

## 4 Units of measurement

The units of measurement used in this International Standard are those of the International System of Units (SI).

## 5 Properties of sediment

### 5.1 General

The transport of sediment depends as much upon the properties of the sediment as upon the hydraulic characteristics of the flow. The properties of sediment are defined by individual particle characteristics and bulk characteristics.

### 5.2 Properties of individual particles

Sediment size is the most commonly used parameter to designate the properties of individual particles. While the size of sediment and its packing directly affect the roughness of the bed, the settling velocity of the particles characterizes their reaction to flow and governs the movement of the sediment. This, in turn, depends upon the relative density, shape and size of the particle.

Since particles of natural sediment are of irregular shape, a single length or diameter has to be chosen to characterize the size. Four such diameters, i.e. nominal diameter, projected diameter, sedimentation diameter and sieve diameter, are used for different particle sizes or purposes (for example, sieve diameter for coarse

and medium particles, sedimentation diameter for fine particles that are not usually separated by sieves). The nominal diameter has little significance in sediment transport, but is useful in the study of sedimentary deposits.

### 5.3 Bulk characteristics

As sediments consist of large numbers of particles differing in size, shape, relative density, settling velocity, etc., it is essential to find some parameters that can represent the characteristics of the group of particles as a whole. Therefore, a sample of sediment is usually divided into class intervals according to characteristics (size, settling velocity, etc.) and the percentage by mass of the total in each interval is determined for the particular characteristic. Frequency distribution curves can be drawn from these data and the sediment parameters (mean, standard deviation, etc.) determined.

## 6 Sampling

Samples of suspended sediment shall be collected as specified in ISO 4363.

## 7 Suspended sediment concentration

### 7.1 Methods for determining the suspended sediment concentration

#### 7.1.1 General

Suspended sediment concentrations may be determined by the following methods:

- a) evaporation method;
- b) filtration method;
- c) hydrometer method (also used for determining particle size).

**NOTE** Although the evaporation method [7.1.1 a)] requires less time, the filtration method [7.1.1 b)] has the advantage that the fractions collected can be photographed on the filters and are available for further examination. However, the filtration method is prone to greater loss of material, whereas in the evaporation method, the ratio of sample mass to tare mass is small. Therefore, no hard and fast guidelines can be provided for the choice of method, and it is necessary to judge each case on its merits.

#### 7.1.2 Evaporation method

The evaporation method is specified in Annex A.

#### 7.1.3 Filtration method

**7.1.3.1** The filtration may be carried out using either a filter paper in a conical glass funnel or a glass-fibre filter disc in a Coors or a Gooch crucible, or a fritted glass or an Alundum crucible, with the application of a vacuum aspirator system to accelerate the passage of the filtrate.

The filtration method using a filter paper and a funnel is specified in Annex B.

**7.1.3.2** Filter discs of glass fibre made without organic bindings, such as Whatman grade 934 AH or Gelman type A/E or Millipore type AP 40 or equivalent<sup>1)</sup>, can be used in a suitable filtration apparatus such as 25 ml to 40 ml capacity Coors or Gooch crucible with adapter.

The filtration method using a glass-fibre filter disk is specified in Annex C.

**7.1.3.3** A fritted glass crucible is made of Pyrex<sup>2)</sup> or other resistance glass, the base of the crucible is fusion-fitted with a porous fritted disc insert.

The crucible is available in different porosity grades, such as coarse, medium and fine (of pore size 40 µm to 60 µm, 10 µm to 15 µm and 4 µm to 5,5 µm, respectively). The particular grade should be selected according to the nature of the sample. The method using a fritted glass crucible is specified in Annex C.

**7.1.3.4** Filtering Alundum<sup>3)</sup> crucibles are similar in shape and size to Gooch or fritted glass crucibles, but made of fused aluminium oxide.

They are made in three degrees of porosity (coarse, medium and fine) and in two types: plain and ignition. The particular type and porosity are selected according to the nature of the sample and purpose of use.

The method of using Alundum crucibles is similar to that for using glass-fibre filter discs or fritted glass crucibles (see Annex C). However, Alundum crucibles are used without the addition of a filtering medium.

The main advantages of using Alundum crucibles are the following.

- a) The crucibles are light, which facilitates greater sensitivity in weighing operations.
- b) The tare masses are less subject to change.

NOTE 1 For samples containing a significant quantity of very fine particles, the last two, viz. the fritted-glass and the Alundum crucible method, are less accurate because of the loss of some of the particles during the filtration and the washing stages.

NOTE 2 There are two other methods, in addition to those mentioned above, that have been used to determine sediment concentration: the hydrometer method and a Gooch crucible with an asbestos layer as a filtering medium. The hydrometer method, although rapid, is not accurate when the sediment concentration is not high or the particles settle rapidly. Moreover, the hydrometer is usually calibrated for 19,4 °C and hence needs to be recalibrated for different temperatures. The hydrometer method is specified in D.1.1. Regarding the use of the asbestos layer as a filtering medium in Gooch crucibles, many countries no longer allow the use of asbestos. Moreover, the pore sizes of asbestos are undefined as they depend on the thickness and uniformity of the layer. Some portion of the asbestos can get washed out from the filtration layer, causing loss in accuracy.

## 7.2 Expression of concentration

The amount of suspended sediment shall be expressed as the mass or volume of dry sediment per unit mass or volume of suspension (i.e. mass/volume or mass/mass etc.).

---

1) Whatman grade 934 AH, Gelman type A/E and Millipore AP 40 are examples of a suitable products available commercially. This information is given for the convenience of users of ISO 4365 and does not constitute an endorsement by ISO of this product.

2) Pyrex is an example of a suitable product available commercially. This information is given for the convenience of users of ISO 4365 and does not constitute an endorsement by ISO of this product.

3) An Alundum crucible is an example of a suitable product available commercially. This information is given for the convenience of users of ISO 4365 and does not constitute an endorsement by ISO of this product.

## 8 Particle-size analysis

### 8.1 Particle-size analysis of suspended sediment

For particle-size analysis, suspended sediment may be classified in terms of the diameter of the suspended solids as follows:

- a) coarse sediment: containing particles with a diameter greater than 0,25 mm;
- b) medium sediment: containing particles with a diameter of 0,062 mm to 0,25 mm;
- c) fine sediment: containing particles with a diameter less than 0,062 mm.

The methods for analysing suspended sediment of these classes are specified in Annex D.

**NOTE** In the case of suspended sediment, grading by particle size of the < 0,062 mm fraction is usually not carried out because of the unimportance of accurately separating the small amount of solid particles that generally exist in suspension. If, however, a more precise separation between the coarse and medium sediments is required, the procedure specified in 8.2 for bed-load and bed material can be used. A particle-size analysis procedure for fine sediment is given in E.3.5.

### 8.2 Particle-size analysis of bed-load and bed material

For the analysis of the bed-load or bed material for particle size distribution and mean diameter of samples, they are classified broadly into those of diameter greater than, and those of diameter less than, 0,5 mm. Classification of material into these two ranges is suitable for the computation of bed-load.

The methods for analysing bed-load and bed material are specified in Annex E.

The particle-size distribution of sediment may be determined by sieving (when particles are all coarse), by a combination of sieving and settling velocity, or indirectly by measuring particle-settling velocities in a column of liquid. It would be advantageous to use only one measure of diameter over the entire range of sizes for all sediments, preferably the sedimentation diameter, but this is not practicable, since large particles will settle very rapidly in the sedimentation liquid. This causes difficulties in dispersion, and would thus require larger equipment. On the other hand, sieve dimensions and the quantity of material available will set a limitation on the size of fine particles. Therefore, in practice, the coarser particles of suspended sediment (diameter greater than 0,25 mm) and the coarser particles of bed-load and bed material (diameter greater than 0,5 mm) are analysed by sieving and all the finer material by sedimentation techniques. This may result in a small abrupt break in the particle size distribution curve, which may be adjusted by the use of the approximate relationship among the diameters, as given in Equation (1):

$$D_{sd} = 0,94 D_{sa} = 0,67 D_{pd} \quad (1)$$

where

$D_{sd}$  is the sedimentation diameter;

$D_{sa}$  is the sieve diameter;

$D_{pd}$  is the projected diameter.

### 8.3 Expression of the particle-size distribution

#### 8.3.1 Frequency-distribution tables

Frequency-distribution tables should be prepared from size analyses to present the data in an orderly form.

In order to draw up the frequency distribution, the total range of sizes (diameters in millimetres) is divided into intervals, called “class intervals”, the number of which will depend on the classes into which the sample has been divided. The percentage of the total mass of the sample falling within each one of these intervals is tabulated. Thus, if an interval has limits of 0,10 mm and 0,08 mm, the percentage of the total mass of the sample falling within this size range is tabulated and called the frequency of that particular class interval.

For the size distribution of coarser material, particularly for bed-load or bed material, the distribution is obtained with unequal class intervals; but for the size distribution of suspended material, a class interval of 0,02 mm is adopted over the range 0,062 mm to 0,50 mm. Particles larger than 0,50 mm and smaller than 0,062 mm are broadly classified as “class > 0,50 mm” and “class < 0,062 mm”, respectively.

#### 8.3.2 Graphical presentation

8.3.2.1 The data from a particle-size analysis may be presented in three different graphical forms:

- as histograms;
- as frequency polygons and frequency curves;
- as cumulative curves or particle-size summation curves.

The simplest manner of depicting the results of a mechanical analysis is to prepare a histogram of the data. The diameter, expressed in millimetres, is usually chosen as the independent variable, with the frequency as the dependent variable. In general, the class intervals are the abscissa, and above each class, a vertical rectangle of width equal to the class interval and height proportional to the frequency in the class, is drawn (see Figure 1).

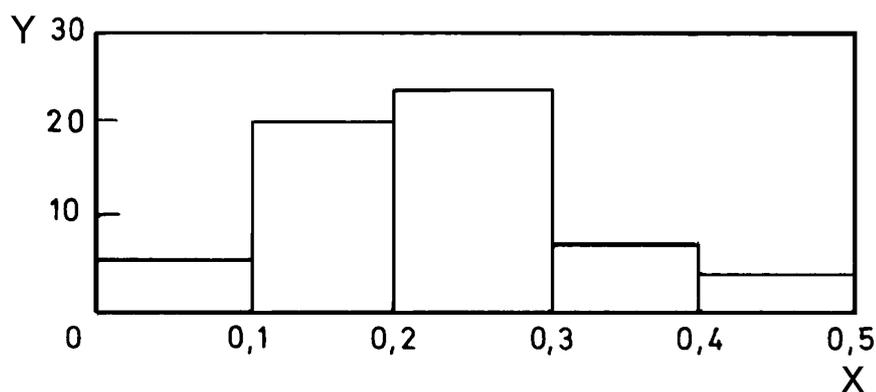

#### Key

- X diameter, expressed in millimetres  
 Y frequency, expressed in mass percent

Figure 1 — Example of a histogram for the presentation of a particle-size distribution

**8.3.2.2** In addition to the use of histograms as frequency diagrams, a common statistical device is to indicate variations in frequency by means of a line diagram instead of rectangular blocks.

Such frequency diagrams are called frequency polygons (see Figure 2).

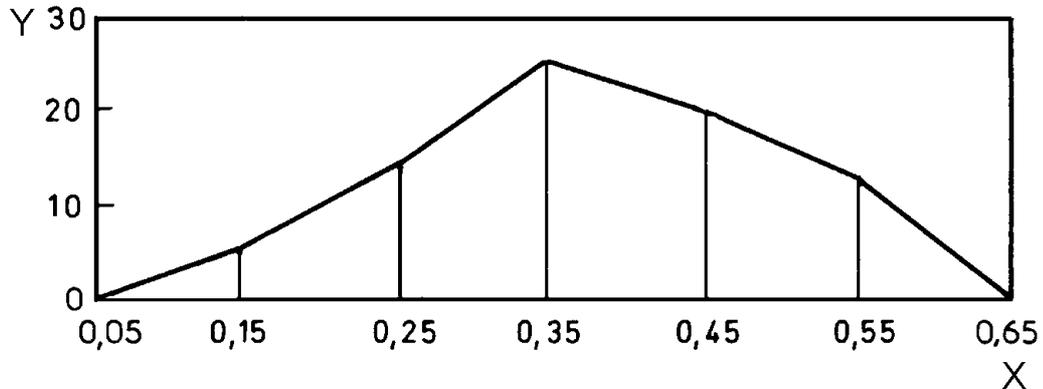

**Key**

- X diameter, expressed in millimetres  
Y frequency, expressed in mass percent

**Figure 2 — Example of a frequency polygon for the presentation of a particle-size distribution**

**8.3.2.3** Cumulative frequency curves readily yield numerical values that serve to describe the properties of the sample in terms of size distribution.

They are based on the frequency analysis of particle sizes, and drawn by choosing a size scale along the horizontal axis, and a frequency scale from 0 % to 100 % along the vertical axis. Either an arithmetic or logarithmic scale can be used for the size. However, the commonest approach is to use a logarithmic scale. In practice, cumulative curves are constructed by plotting ordinates, which represent the total amount of material larger or smaller than a given diameter. Two types of cumulative curves are possible: the “more than” curve and the “less than” curve. Either may be used, as they provide the same type of information. Figure 3 gives an example of a “more than” cumulative curve.

**8.3.3 Basic distribution of bed material**

The size distribution of bed material more or less follows logarithmic-normal, or lognormal, distribution, i.e. the logarithm of the variable is distributed normally.

Differentiation of the cumulative distribution function leads to Equation (2):

$$P(x)dx = \varnothing(u)du \frac{1}{\sigma\sqrt{2\pi}} \exp\left\{-\left[\frac{(\lg x - \lg \varepsilon)^2}{2\sigma^2}\right]\right\} d(\lg x) \quad (2)$$

where, by definition,

$$\text{mean}(\lg x) = \lg \varepsilon \quad (3)$$

$$\text{variance}(\lg x) = \text{mean}\left[(\lg x - \lg \varepsilon)^2\right] = \sigma^2 \quad (4)$$

Thus, the symbol  $\varepsilon$  does not denote the mean of the variable  $x$ ;  $\lg \varepsilon$  is defined as the mean of  $\lg x$ .

NOTE The variable  $x$  in this case is  $D$ , the particle-size diameter.

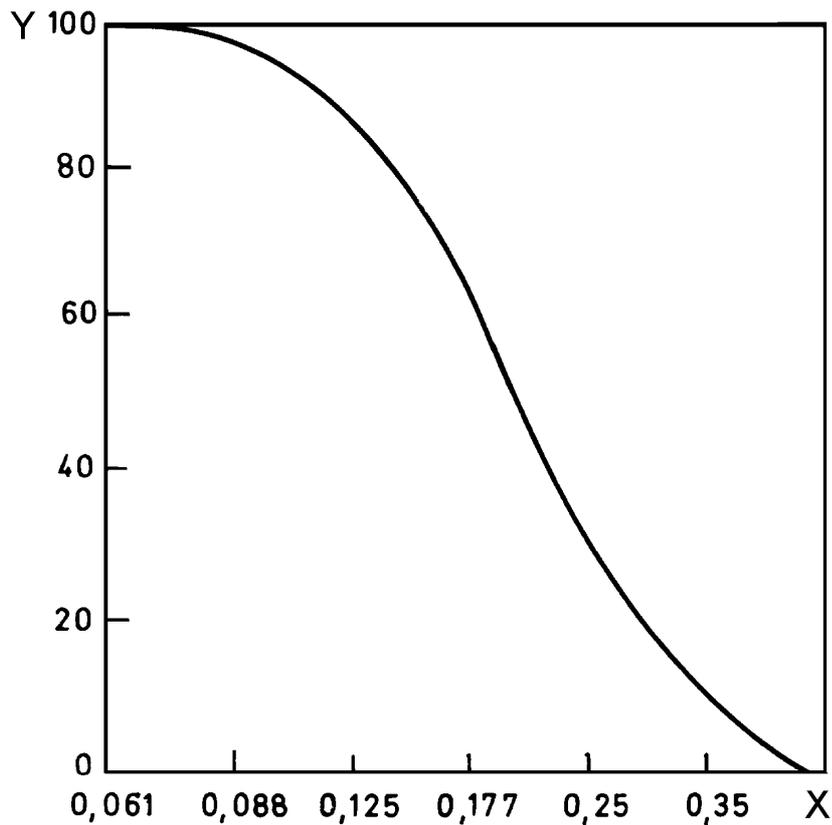

**Key**

X diameter (logarithmic scale), expressed in millimetres

Y frequency, cumulative mass percent of particles with a diameter greater than the selected value

**Figure 3 — Example of a cumulative frequency curve for the presentation of a particle-size distribution**

**9 Determination of relative density**

The method for determining the relative density is specified in Annex F.

NOTE The density can be computed from a knowledge of the relative density.

**10 Determination of particle-size distribution characteristics**

The method for determining the particle-size distribution characteristics is specified in Annex G.

**11 Data processing**

For both manual and automatic data processing, systematic forms and procedures are required, depending on the specific needs.

## Annex A (normative)

### Determination of the concentration of suspended sediment by the evaporation method (for coarse sediment particles)

#### A.1 Procedure

**A.1.1** Determine the volume and the total mass of the sample (sediment + water) plus bottle, with a capacity usually not less than 1 l (except in some countries where a smaller sample size is used) to the nearest 0,5 g. Record this mass as the gross mass.

**A.1.2** Allow the sample to stand undisturbed so that the sediment settles out from the suspension. Decant the sediment-free liquid after it appears to the eye to be clear.

**A.1.3** Wash the remaining sediment from the bottle, by means of a stream of gravity-fed deionized or distilled water from a wash-bottle, into a previously weighed dry evaporating dish. Loosen the sediment adhering to the sides of the bottle by means of a rubber-tipped glass rod, ensuring that there is no loss of material during this process.

Determine the mass of the empty bottle after drying, using the same balance, and record this as the tare mass.

**A.1.4** Dry the sample in the evaporating dish on a steam-bath or in a drying oven. If necessary, add successive sample portions to the same dish after evaporation. The sample should be dried initially at 85 °C to 95 °C to prevent splattering and loss of sample. After it appears dry, then heat the evaporated sample for at least 1 h in an oven at 101 °C to 105 °C, cool the dish in a desiccator to balance temperature and weigh quickly. Repeat the cycle of drying, cooling and weighing until a constant mass is obtained, i.e. until the loss of mass is less than 1 mg. Otherwise, dry the evaporated sample overnight at 101 °C to 105 °C, cool the dish in a desiccator to balance temperature and weigh the dish and contents quickly to the nearest 0,001 g.

#### A.2 Expression of results

Calculate the amount of suspended sediment, in accordance with Equation (A.1) to determine the mass fraction,  $w_{SS}$ , of the suspended solids or in accordance with Equation (A.2) to determine the concentration,  $C_{SS}$ , of the suspended solids:

$$w_{SS} = \frac{m_4 - m_3}{m_2 - m_1} \quad (\text{A.1})$$

where

$m_1$  is the tare mass, in grams, of the bottle;

$m_2$  is the gross mass, in grams, of the bottle plus sample;

$m_3$  is the mass, in grams, of the empty evaporating dish;

$m_4$  is the mass, in grams, of the evaporating dish plus dried sediment.

$$C_{\text{ss}} = \frac{m_4 - m_3}{V} \quad (\text{A.2})$$

where  $V$  is the volume of the sample and the other variables are as given for Equation (A.1).

Express the result in appropriate units.

### **A.3 Limitations on the method**

This method is satisfactory if dealing with coarse sediment particles. With finer-grained sediments, the settling time increases until a point is reached at which the method becomes impractical. Also, it becomes undesirable to decant liquid from a point close to the top of the deposited material, because of the danger of withdrawing some of the extremely fine particles. The transfer of sediment to an evaporating dish becomes difficult owing to the relatively large volume of water used for washing, which may necessitate another settling period. The use of flocculating agents will reduce the settling time, but this introduces additional material and hence requires a correction factor, which is difficult to assess with precision in routine estimates.

This method is not accurate enough for samples containing a high concentration of dissolved salt. The dissolved salt contributes additional mass, which can be significant, especially for samples containing small amounts of suspended sediment.

## Annex B (normative)

### Determination of the concentration of suspended sediment by the filtration method using filter paper

#### B.1 Procedure

**B.1.1** Exclude large floating particles (floating plants, wastes, etc.) from the sample if their inclusion is not desired. For better accuracy, choose a sample volume to yield between 25 mg and 200 mg dried sediment as the final result. Determine the volume and the total mass of the sample (sediment + water) plus bottle to the nearest 0,5 g. Record this mass as the gross mass.

**B.1.2** Selection of filter paper: Acid-washed, hard-finished filter paper sufficiently retentive for fine particles, like Whatman No. 42 filter paper (average pore size 1,1  $\mu\text{m}$ ) can be used. However, for a sample which does not contain a significant quantity of fine particles, Whatman No. 40 or 41 filter paper (average pore size 2,4  $\mu\text{m}$  and 4,1  $\mu\text{m}$ , respectively), which are faster-speed filter papers can be used. If the filtrate looks turbid, indicating fine particles passing through the Whatman No. 40 or 41 filter, then a Whatman No. 42 filter should be used. The rate of filtration through No. 42 filter paper is slow and hence should not be used for gelatinous sediment and need not be used for coarse sediment.

**B.1.3** Dry the filter paper overnight in an oven at 101 °C to 105 °C, cool in a desiccator to bring it to room temperature and weigh quickly (to avoid absorption of moisture from atmosphere) to the nearest 0,001 g. Record this value as the tare mass of the filter paper.

Fit the filter paper into a funnel. To fit it properly, moisten it with a little water, press it down to the sides of the funnel either with a clean forefinger or with a flattened glass rod. Place the funnel containing the properly fitted filter paper in a funnel stand or support it vertically in some other way. Place a clean beaker or other transparent container below the stem of the funnel to collect the filtrate.

**B.1.4** Allow the sample to stand undisturbed for a period of time and then pour the top portion of the water-sediment mixture into the funnel, allowing the water to percolate. To direct the water-sediment mixture into the funnel, pour the mixture down a glass rod onto the filter paper, directing the liquid against the side of the filter paper and not at the apex; the lower end of the glass rod should be very close to, but not quite touching, the filter paper. The paper is never filled completely; the level of the liquid should come no closer than 5 mm to 10 mm to the edge of the paper.

Slowly pour most of the watery part of the sample onto the filter paper. Allow the water to percolate normally. After the water has passed through the filter paper, wash the sediment adhering to the inside of the sample bottle onto the filter paper by means of a jet of distilled (or deionized) water, from a wash bottle. If necessary, loosen the firmly adhered sediment by means of a rubber-tipped glass rod.

Weigh the empty sample bottle after drying, and record this value as the tare mass.

**B.1.5** To remove dissolved salt, if any, wash the contents on the filter paper with small portions of gravity-fed deionized or distilled water from a wash bottle. Direct the water jet as near the top of the filter paper as possible and then gradually towards apex of the cone. Let each portion of the wash water run through before adding the next. Continue washing until about 5 ml of the wash water gives no opalescence with a drop or two silver nitrate solution.

**B.1.6** After all the water has passed through the filter paper, fold and place the paper in a dry evaporating dish.

Dry the contents of the evaporating dish on a steam-bath or in a drying oven at about 85 °C to 95 °C until all visible water is lost, then heat at 101 °C to 105 °C in an oven for overnight.

Remove the evaporating dish and its contents from the oven and place in a desiccator to cool to room temperature.

Quickly weigh the filter paper with the dried sediment to the nearest 0,001 g, taking care that no sediment particles are lost from the filter paper while taking it out of the evaporating dish and weighing. Record this value as the gross mass of the filter paper plus dried sediment. Make a blank correction.

**B.1.7** For the blank correction, fit another dried and weighed (initial mass) filter paper of the identical size in a funnel. Pass the same volume of distilled water (as that of the sample volume) through it. Dry the filter paper overnight at 101 °C to 105 °C, cool in a desiccator and weigh as described in B.1.6. Calculate any loss in mass of the filter paper due to the passing of water through it from its initial mass minus final mass. Add the value of the mass loss to the gross mass of the filter paper plus dried sediment as the blank correction.

## B.2 Expression of results

Calculate the amount of suspended sediment, in accordance with Equation (B.1) to determine the mass fraction,  $w_{SS}$ , of the suspended solids or in accordance with Equation (B.2) to determine the concentration,  $C_{SS}$ , of the suspended solids:

$$w_{SS} = \frac{(m_8 - m_7) + (m_5 - m_6)}{m_2 - m_1} \quad (\text{B.1})$$

where

$m_1$  is the tare mass, in grams, of the bottle;

$m_2$  is the gross mass, in grams, of the bottle plus test portion;

$m_5$  is the initial mass of the dry filter paper used for blank correction purpose;

$m_6$  is the final mass of the dried filter paper used for blank correction purpose;

$m_7$  is the tare mass, in grams, of the dry filter paper used to filter the test portion;

$m_8$  is the gross mass, in grams, of the filter paper with dried sediment.

$$C_{SS} = \frac{(m_8 - m_7) + (m_5 - m_6)}{V} \quad (\text{B.2})$$

where  $V$  is the volume of the sample and the remaining variables are the same as for Equation (B.1).

Express the result in the appropriate units.

## B.3 Recommended precautions for this procedure.

**B.3.1** If the water-sediment mixture is of such a large volume that all of it cannot be poured in at the start of the filtration, it is necessary either to add it intermittently or to arrange the apparatus so that it filters automatically. This may be accomplished by inverting the bottle containing the sample with its opening at the desired water level in the filter.

**B.3.2** For coarse sediment, allow the sample to stand undisturbed before filtration so that the sediment settles out from the suspension. Decant off the sediment-free liquid portion after it appears to the eye to be clear. Discard the decanted water and filter the settled sediment as in B.1.4. This will reduce filtration time. For samples containing a significant proportion of fine particles or having a very small amount of sediment, the entire sample should be filtered without sedimentation and decantation.

## Annex C (normative)

### Determination of the concentration of suspended sediment by the filtration method using a Gooch or other crucible

#### C.1 Procedure

**C.1.1** For better accuracy, choose a sample volume to yield between 25 mg and 200 mg dried sediment. Remove large floating particles (floating plants, wastes, etc.) if their inclusion is not desired in the final result. Determine the volume and the total mass of the sample (sediment + water) plus bottle to the nearest 0,5 g. Record this value as the gross mass.

**C.1.2** Allow the sample to stand undisturbed for a period of time so that the sediment settles out from the suspension. Decant as much of the sediment-free water as possible, if it appears to the eye to be clear, without disturbing the sediment. Discard the decanted water.

Wash the remaining water-sediment mixture into a beaker, using distilled or deionized water. Loosen the firmly adhered sediment particles, if any, by means of a rubber-tipped glass rod and transfer all the sediment particles into the beaker.

Determine the mass of the dry, empty sample bottle to the nearest 0,5 g. Record this value as the tare mass of the bottle.

NOTE Transferring samples to a bigger or secondary container can result in the loss of some of the sample.

**C.1.3** Allow the sediment to settle in the beaker, then, if possible, decant again.

**C.1.4** Prepare and insert the appropriate filtering medium. Insert a circular micro-fibre glass filter and pre-filter disc firmly over the fritted base of the crucible. To prepare the glass-fibre filter disc, insert the disc with wrinkled side up into a 25 ml to 40 ml capacity Coors or Gooch crucible with adapter.

If crucibles fitted with permanent porous plates, such as fritted glass or alundum crucibles, are used, then no preparation of a filter-mat is required.

**C.1.5** Apply a vacuum and wash the disc with three successive 20 ml volumes of distilled water. Continue suction to remove all traces of water. Discard the washings. Remove the crucible and filter combination. Dry it in an oven at 101 °C to 105 °C for 1 h. Cool in a desiccator to balance temperature, weigh quickly and determine mass of the crucible. Repeat the cycle of drying, cooling and weighing until a constant mass is obtained or until loss in mass is less than 1 mg between successive weighings. Record this value to the nearest 0,001 g. Store the crucible with filter in a desiccator until needed.

**C.1.6** Place the crucible with filter in position in the vacuum system and begin suction. If required, wet the filter with a small volume of distilled water to seat it. Transfer the water-sediment mixture quantitatively from the beaker into the crucible, wash the beaker with distilled or deionized water, and take all the particles with washings into the crucible. Allow the mixture to filter.

To remove dissolved salts, if any, wash the contents of the crucible with small portions of distilled or deionized water from a wash bottle. Let each portion of the wash-water run through before adding the next. Continue washing until 5 ml of the wash water gives no opalescence with a drop or two silver nitrate solution.

**C.1.7** When filtration is complete, dry the crucible and contents at 101 °C to 105 °C for at least 1 h. Cool in a desiccator and weigh.

Repeat the cycle of drying, cooling in the desiccator and weighing until a constant mass is obtained. Weigh the crucible and contents to the nearest 0,001 g.

Record this value as the gross mass of the crucible, filtering medium and dried sediment.

## C.2 Expression of results

Calculate the amount of suspended sediment, in accordance with Equation (C.1) to determine the mass fraction,  $w_{ss}$ , of the suspended solids or in accordance with Equation (C.2) to determine the volume fraction,  $C_{ss}$ , of the suspended solids:

$$w_{ss} = \frac{m_{10} - m_9}{m_2 - m_1} \quad (\text{C.1})$$

where

$m_1$  is the tare mass, in grams, of the bottle;

$m_2$  is the gross mass, in grams, of the bottle plus sample;

$m_9$  is the tare mass, in grams, of the crucible with filtering medium;

$m_{10}$  is the gross mass, in grams, of the crucible with filtering medium and dried sediment.

$$C_{ss} = \frac{m_{10} - m_9}{V} \quad (\text{C.2})$$

where  $V$  is the volume of the test portion and the remaining variables are as given for Equation (C.1).

Express the results in the appropriate units.

## C.3 Recommended precautions for this procedure

For small amounts of solids or if the sample contains a significant proportion of fine particles that do not settle quickly, the entire sample should be filtered without sedimentation.

## Annex D (normative)

### Determination of the particle-size distribution of suspended sediment

#### D.1 High sediment concentrations

##### D.1.1 Estimation of total suspended load — Hydrometer method

###### D.1.1.1 General procedure

If the sediment concentration is high, the total suspended load can be measured with sufficient accuracy by using a hydrometer. The main advantage of this method is rapidity.

After determining the mass and the volume of the sample, vigorously stir it for a few seconds in the original container using a “figure-eight” motion in order to obtain a homogeneous mixture. Introduce the hydrometer into the mixed sample immediately after stopping stirring and take the reading as soon as possible. The time after which the reading should be taken is specified in Table D.1 and depends on the temperature of the mixed sample.

**Table D.1 — Time after which hydrometer readings are to be taken in relation to temperature of the sample**

Temperature °C	Time s
5	153
6 to 10	146
11 to 15	127
16 to 20	112
21 to 25	102
26 to 30	92
31 to 35	84
36 to 40	77
41 to 45	70
46 to 50	64

NOTE From the mass and volume of the sample, the total amount of suspended load and dissolved matter can be computed from the density reading on the hydrometer.

###### D.1.1.2 Use of the hydrometer

A hydrometer is illustrated in Figure D.1. The depth to which the hydrometer is immersed gives the density of the sediment mixture, including dissolved material. Before taking the hydrometric reading, the hydrometer should be pushed down gently by about 1 mm or 2 mm and allowed to return slowly to the equilibrium position.

As the hydrometer is usually calibrated for 19,4 °C, it should be calibrated in distilled water before use, and a chart or temperature correction curve should be prepared for measurements at different temperatures.

The concentration, in grams per litre, of the total sediment in suspension plus dissolved material is given by Equation (D.1):

$$C_{ss} + C_d = (R_H - R_0) \times K \quad (D.1)$$

where

$C_{ss}$  is the suspended sediment concentration, in grams per litre;

$C_d$  is the concentration, in grams per litre, of dissolved matter;

$R_H$  is the hydrometric reading of the sample;

$R_0$  is the hydrometric reading of distilled water at the same temperature, obtained from the calibration chart;

$K$  is the hydrometer factor for converting the readings to grams per litre, which can be determined with a salt solution of known concentration.

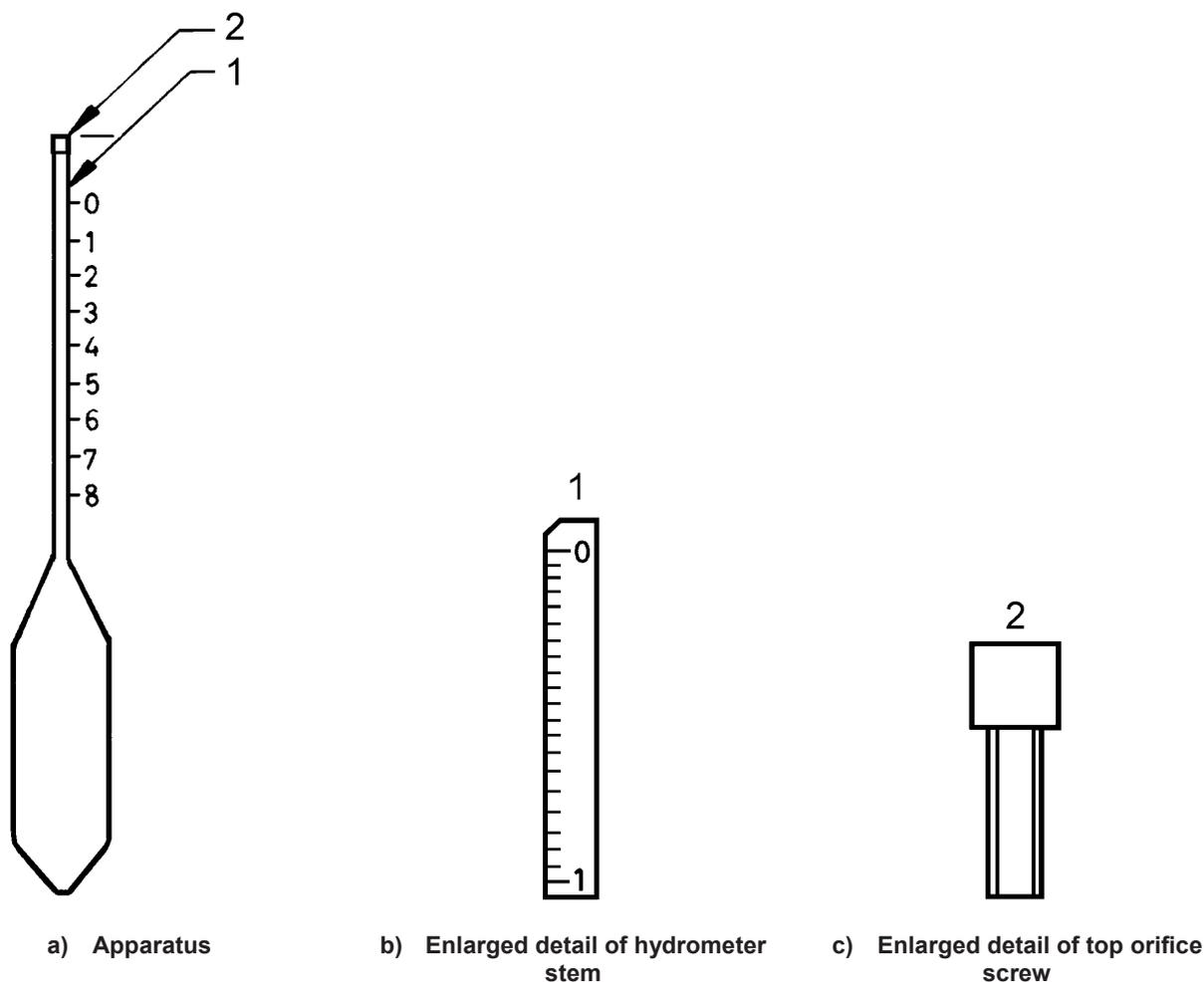

**Key**

- 1 hydrometer stem
- 2 top orifice screw

Figure D.1 — Hydrometer

### D.1.2 Estimation of coarse sediment

Collect a sufficient volume of sample (normally 5 l) for analysis and determine its mass and volume. Pass the entire sample, including water and sediment, through a sieve of aperture size 250 µm into a container of suitable size. Wash the original sample container with distilled water to ensure complete removal of sediment. Wash the sediment retained on the sieve thoroughly by means of a jet of distilled water until all the medium and fine particles have been washed through the sieve and into the container. Wash and dry the particles retained on the sieve and weigh. Calculate the concentration of the coarse fraction of the sediment,  $C_{cf}$ , in grams per litre of sample.

### D.1.3 Estimation of medium sediment

Add gravity-fed deionized or distilled water to the sediment collected in the container to make up the depth to 10 cm. Stir for a few seconds using a “figure-eight” motion and allow to stand for the required time corresponding to the temperature of the water as indicated in Table D.2.

Pour the supernatant water into a covered container. Repeat this process of separation of sediment by the decantation of the supernatant liquid followed by filling the container up to the specified height with clear water until the supernatant water is completely clear. After the final washing and decantation process, dry the sediment that has settled in the beaker in an oven and weigh. Calculate the concentration of the medium fraction,  $C_{mf}$ , in grams per litre of sample.

NOTE Table D.2 is not applicable for samples containing light, porous material or heavy mineral particles.

**Table D.2 — Time taken for particles of diameter greater than 0,062 mm to fall through 10 cm column of water at different temperatures**

Temperature °C	Time s
2	45
6 to 10	40
11 to 15	35
16 to 20	31
21 to 25	27
26 to 30	24
31 to 35	21
36 to 40	19
41 to 45	17
46 to 50	15

### D.1.4 Estimation of fine sediment and dissolved matter

Calculate the estimated fine fraction of the sediment and dissolved matter content,  $C_{ff,d}$ , in grams per litre of sample, from Equation (D.2):

$$C_{ff,d} = C_T - (C_{cf} + C_{mf}) \quad (D.2)$$

where

$C_T$  is the estimated total sediment concentration, in grams per litre, determined in D.1.1;

$C_{cf}$  is the estimated coarse sediment concentration, in grams per litre, determined in D.1.2;

$C_{mf}$  is the estimated medium sediment concentration, in grams per litre, determined in D.1.3.

## D.2 Low sediment concentrations

### D.2.1 Estimation of coarse sediment

Proceed as described in D.1.2.

### D.2.2 Estimation of medium sediment

Proceed as described in D.1.3.

### D.2.3 Estimation of fine sediment — Gravimetric method

**D.2.3.1** If the sediment concentration is low, its estimation by the hydrometer method is difficult and gives inaccurate results. In such cases, estimation of total sediment is first carried out analytically by the gravimetric method (see D.2.3.2). Coarse and medium sediments are then deducted from the total mass of sediment to obtain a fine sediment fraction. Alternatively, where only the fine sediment is required, instead of analysing the total sample of sediment by the gravimetric method, it is easier to separate the coarse sediment by sieving (see D.1.2) and the medium sediment by decantation (see D.1.3) from the total sample before analysing the remaining sediment, consisting only of the fine fraction, by the gravimetric method.

**D.2.3.2** The procedure for the gravimetric method is to allow a sample of 4 l to 5 l to remain undisturbed in a covered container so that the sediment settles. For rapid settling of the sediment, add 2 ml to 3 ml of a 5 % by volume alum solution when the sediment concentration is high, and 2 ml to 3 ml of a 1 % by volume solution when the sediment concentration is low. When all the particles have settled, remove the supernatant water by careful siphoning and transfer the sediment from the container to a small beaker by means of gravity-fed deionized or distilled water from a wash bottle, taking care that no material is lost during this process. Carefully transfer the contents of the beaker onto a filter paper fitted in a funnel, again by means of gravity-fed deionized or distilled water from a wash bottle. Wash the residue on the filter paper a few times to remove the alum. When the water has completely drained, dry the sample on a sand bath to a constant mass. Take care to remove the material adhering to the filter paper by means of a fine brush so that no material is lost while weighing.

Deduct the concentrations of coarse and medium sediments as determined in D.1.2 and D.1.3, respectively, from the total sediment concentration to obtain the concentration of fine sediment.

## Annex E (normative)

### Determination of the particle-size distribution of bed-load and bed material

#### E.1 Principle

The sample (or dry sieving, in the case of a dry sample) is washed through a 0,50 mm mesh sieve. The portion retained on the sieve is analysed by drying and sieving through a further series of sieves.

The material passing through the sieve is analysed by the appropriate technique.

#### E.2 Sieve analysis of particles of diameter larger than 0,5 mm

**E.2.1** In order to ensure that the data obtained by sieve analysis are comparable, the following items should be standardized, in advance, for all samples:

- a) size of the test sample (see E.2.2);
- b) type of sieving (wet or dry) (see E.2.3);
- c) size of the sieves (see E.2.4);
- d) method of shaking (see E.2.5);
- e) duration of sieving or end-point (see E.2.6).

**E.2.2** The ideal quantity of sample to be used is that which covers each sieve with a layer not more than one particle deep. This implies that the mass of sample should be reduced with the smaller sieves. On the other hand, a sufficiently large sample has to be used to eliminate errors in sampling (see ISO 4364) and weighing. In practice, the size of the sample depends upon the diameter of the coarsest particles constituting the routine samples received by the laboratory. The mass of the sample on the 200 mm diameter sieves should be 100 g to 150 g for coarse sand and 40 g to 60 g for fine sand.

**E.2.3** Material may be sieved either wet or dry. While wet sieving has the apparent advantage of separating particles finer than sieve openings by washing, dry sieving is to be preferred since, in wet sieving, the formation of a water film on the screen and on the particles does not allow complete separation.

**E.2.4** A set of sieves with square mesh openings, the sizes of which vary in a consistent manner, is normally used.

**EXAMPLE** A set of sieves with square mesh openings of 4 mm, 2 mm, 1 mm and 0,5 mm, having a diameter of 200 mm and a height of 50 mm.

This example is a geometric series, with the size of the mesh openings changing by a factor of 2, but there are alternative systems based on factors of  $\sqrt{2}$  and  $4\sqrt{2}$ .

**E.2.5** A mechanical shaker should be used to perform the sieving in one operation. With the weighed sample placed on the mesh of the coarsest sieve, the sieves should be agitated horizontally so that the sample particles move in an irregular motion over the sieves. Care should be taken to ensure that aggregates are not retained and that sieving is complete.

**E.2.6** Sieving should be continued for a minimum period of 10 min or until less than 0,2 % of the sample passes through the mesh in any 5 min sieving period. The sieving operation is carried out in 5 min stages, at the end of each of which the sieves are emptied and brushed in order to reduce the blocking of the apertures. The sediment fraction retained on each sieve should be carefully collected in containers and the mass of each fraction determined and recorded.

NOTE 1 Sieving is probably the easiest and most popular method of size analysis. This method is being used routinely to determine the particle-size distribution not only of the > 0.05 mm fraction, but also of the finer particles down to 0,075 mm diameter. Samples not containing a significant proportion finer than 0,075 mm diameter can be analysed by this method. The mesh sizes of the set of sieves depend on the type of information to be obtained from particle-size analysis

NOTE 2 There is always an element of chance as to whether a particle will or will not pass through a given sieve. Whether or not a particle passes through the sieve as it moves over the sieving surface depends not only on its dimension but also on the angle at which it is presented. Therefore, as the elongation and angularity of the particles increase, it is necessary to view the diameters obtained from sieve analysis with caution.

NOTE 3 In addition to the effects of particle shape on the validity of sieve analyses, the following sources of error, which might or might not be serious, can exist, depending upon the equipment available and the refinement of the technique:

- a) incomplete sieving;
- b) faulty manipulation;
- c) sieve mesh defects;
- d) uncertainty in weighing.

Incomplete sieving is generally the most serious defect because it is not practical to sieve for a sufficient length of time to accomplish complete grade separation.

The error in sieve analysis resulting from faulty manipulation is introduced largely in the removal of the material from a sieve. Angular particles always have the tendency to become wedged in the mesh; a brush can be used to facilitate the removal of such material. It is necessary to exercise extreme care, however, to avoid damaging the mesh or forcing the particles through the mesh.

It is important to check the finer meshes frequently for wear or damage using a microscope.

Errors in weighing, other than accidental, can be controlled by using a balance of sufficient sensitivity.

## **E.3 Method of analysis of particles of diameter smaller than 0,5 mm using sedimentation techniques**

### **E.3.1 General**

#### **E.3.1.1 Types of methods**

Analysis of the portion of sediment that passes through the 0,5 mm sieve may be carried out by one of the following methods:

- a) pipette method;
- b) hydrometer method;
- c) siltometer method, using
  - 1) an optical level siltometer,
  - 2) a mechanical siltometer;

- d) bottom-withdrawal tube;
- e) visual-accumulation tube.

**E.3.1.2** For very fine material (diameter less than 0,062 mm), the pipette method is considered to be the most accurate method, but it is time-consuming. For the same size range, the hydrometer method, which is the simplest and most rapid, may also be used.

**E.3.1.3** For grading particles with diameters in the range 0,062 mm to 0,50 mm, a siltometer is used. If the bulk of the material lies within this particle-size range, this method gives more accurate results than sieving.

**E.3.1.4** Bottom-withdrawal tubes may be used over a wide range of particle sizes below 0,50 mm.

The visual-accumulation tube sand-size analyser, which is useful for the analysis of sand, that is, for the size range 0,062 mm to 2 mm, may also be used.

**E.3.1.5** These methods of determining particle size are based on the fact that, under the influence of gravity, a spherical particle will ultimately attain a constant velocity (setting velocity), which can be expressed as in Equation (E.1):

$$K_{\text{dr}} D^2 \pi \rho \frac{v^2}{8} = \frac{1}{6} \pi D^3 g (\rho_s - \rho) \quad (\text{E.1})$$

where

$K_{\text{dr}}$  is the drag coefficient, depending on the Reynolds number:

$$Re_{\text{dr}} = \frac{vD}{\eta} \text{ and models the shape of the particle;}$$

$D$  is the diameter of the particle;

$\rho$  and  $\rho_s$  are the densities of the liquid and the particle, respectively;

$v$  is the settling velocity;

$g$  is the acceleration due to gravity;

$\eta$  is the kinematic viscosity of the liquid.

If the Reynolds number is small ( $Re_{\text{dr}} < 0,1$ ), the value of  $K_{\text{dr}}$  does not depend on the particle size, but only on the Reynolds number.

From  $K_{\text{dr}} = 24/Re_{\text{dr}}$ , Stokes' law can be expressed as given in Equation (E.2).

$$v = 1/18 \left( \frac{\rho_p - \rho}{\rho} \right) \times \frac{g}{\eta} \times D^2 \quad (\text{E.2})$$

It can be noted that many natural sediments have a density of 2 650 kg/m<sup>3</sup>

Equation (E.1) can thus be reduced to the simple form:

$$v = f(D, K_{\text{dr}})$$

This relationship has been approximated in Figure E.1.  $K_{dr}$  depends on  $Re_{dr}$  and a shape factor  $F$ . It should be noted that for  $Re_{dr} < 0,1$ , the grain diameter ( $D$ ) can be defined accurately from the settling velocity,  $v$ . However, for  $Re_{dr} > 0,1$ , only an approximation is possible.

**E.3.1.6** The pipette method and the hydrometer method are suitable for analysis of particles of sizes less than 0,062 mm, but since particles of such small sizes are generally not significant in the bed-load or bed material, these methods are not used for routine analysis of such bed samples. However, in special cases where it is necessary to know the distribution of material finer than 0,062 mm, the use of the pipette method is justified.

**E.3.1.7** When a Siltometer and a bottom-withdrawal tube are used, the sedimentation tube should be examined for possible deposits at the end of the experiment.

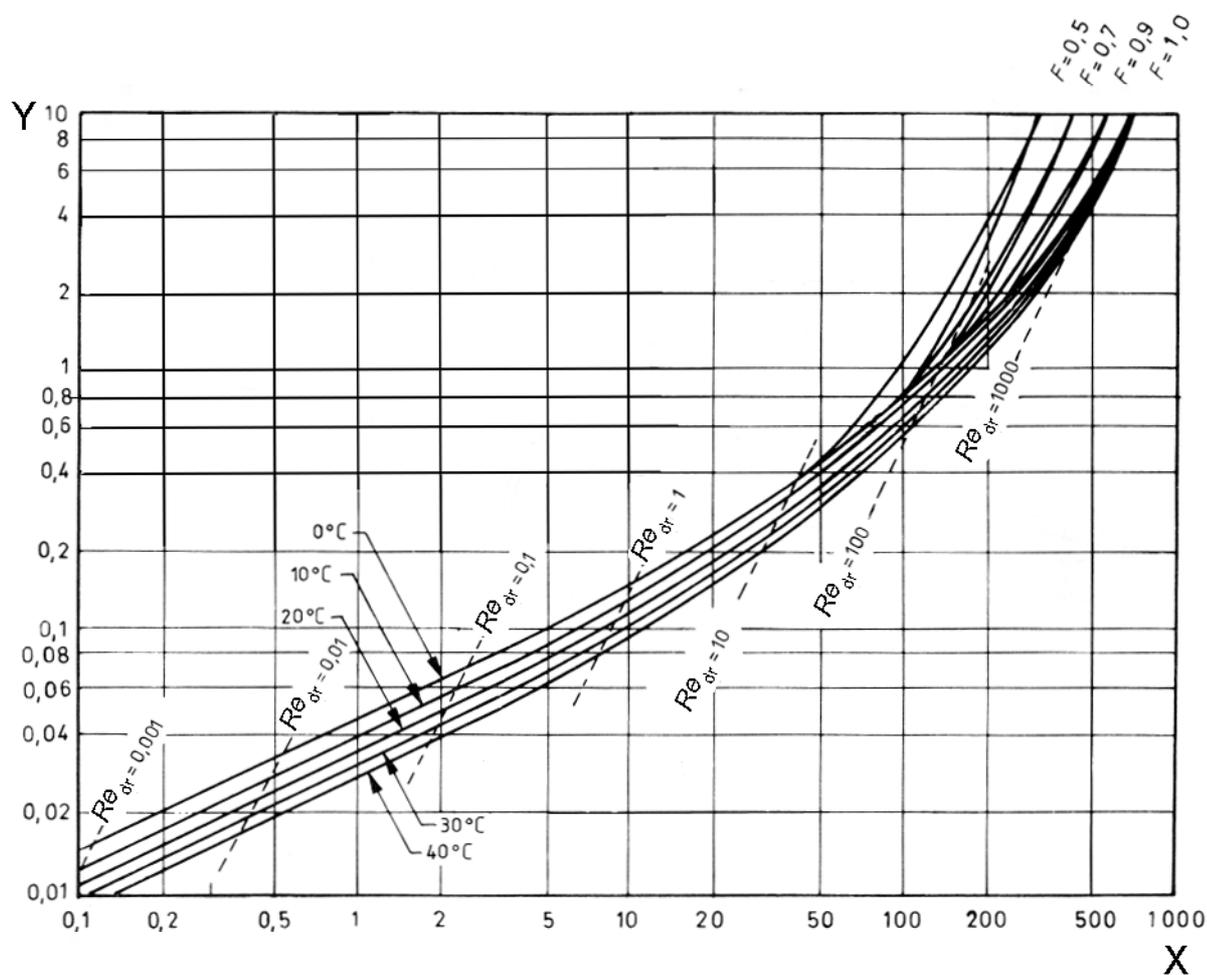

**Key**

X settling velocity,  $v$ , expressed in millimetres per second

Y sieve diameter,  $D_{sa}$ , expressed in millimetres

$Re_{dr}$  is the Grain Reynolds number, which equals  $v \times D_{sa} / \eta$

$$F = \frac{c}{\sqrt{ab}}$$

where  $a$ ,  $b$  and  $c$  are the major, intermediate and minor axes, respectively;

NOTE  $\rho = 2\,650 \text{ kg/m}^3$  and  $\rho_s = 1\,000 \text{ kg/m}^3$ .

**Figure E.1 — Particle diameter versus settling velocity**

### E.3.2 Siltometer method

Siltometers work on the principle of the different settling velocities of particles in a column of liquid (usually water). They allow a direct determination of the rate of accumulation of the material by measuring the sediment deposited at the bottom of the tube.

In the operation of siltometers, assumptions are made that the particles to be measured are evenly distributed at the start of the test and that they have the same relative density. Furthermore, there is an implicit assumption that the settling velocity of each particle is independent of the others, a condition which is considered applicable if the concentration of the particles is not high (up to 2 %, although such methods can be used for concentrations up to 5 %).

Particles of different sizes fall through the column of water at different velocities; the size distribution of the particles varies throughout the suspension and the concentration decreases as sedimentation continues.

The sample should be allowed to settle for a time sufficiently long to allow all particles over a certain selected size to fall to the bottom of the column of water and the different fractions should be collected in separate pockets that move into position under the column of water at predetermined intervals of time. Figure E.2 illustrates the essential features of a siltometer, which consists of four main parts:

- a) sedimentation tube, made of brass tubing, with a uniform inside diameter of about 6 cm and a length of 2 m, attached to a lever (Figure E.2, item 2) which, when actuated, can raise the entire tube through about 10 mm;
- b) sedimentation dropping device (Figure E.2, item 1), made of two funnels, the purpose of which is to introduce the sediment under water. The funnels fit tightly together, allowing the sediment to be introduced without immediately entering the sedimentation tube. At the desired time, the inside funnel is lifted and the sediment enters the main tube;
- c) sediment collecting device, consisting of a circular aluminium trough (Figure E.2, item 3), divided around its circumference into 20 individual pockets. The apparatus is so constructed that this collection trough can be moved around 1/20th of its circumference by operating a lever manually at any desired time;
- d) container (Figure E.2, item 5), with a slender, graduated stem, used when a volumetric measurement of the sediment collected in each pocket is desired.

The procedure for analysing the particle-size distribution of a sediment using the mechanical (Puri's) siltometer is as follows.

Fill the circular trough with water to a depth of 100 mm and place a rubber stopper in the pocket (this should be pocket number 20) immediately below the sedimentation tube. Lower the tube by means of the lever (Figure E.2, item 2), so that the stopper fits tightly into the end of the tube. Fill the sedimentation tube with water and insert snugly the inner funnel. Measure the temperature of the water in the tube. Place a sample of about 10 g of sediment in the dropping device and cover with water. Separation into fractions by size can now commence. Quickly remove the inserted funnel and simultaneously start a stopwatch. Remove the remaining funnel section as rapidly as possible and tightly insert a rubber stopper into the top of the sedimentation tube. As soon as the rubber stopper has been inserted tightly into the top of the sedimentation tube and the tube has been raised by actuating the lever, immediately rotate the trough by means of the lever so that the next pocket (i.e. number 1) is positioned below the tube outlet to collect the sediment. Allow sedimentation into this first pocket to continue for 26 s, then rotate the trough one division to place the second pocket (number 2) in position. Continue rotation of the trough at 4 s intervals up to 66 s, then at 10 s intervals up to 106 s, and then after 136 s, 166 s, 196 s, 376 s and 556 s. When separation has been completed, which takes less than 10 min, filter the material in each compartment, dry it and weigh.

This procedure is suitable only for sediments with particle sizes between about 0,06 mm and 0,60 mm.

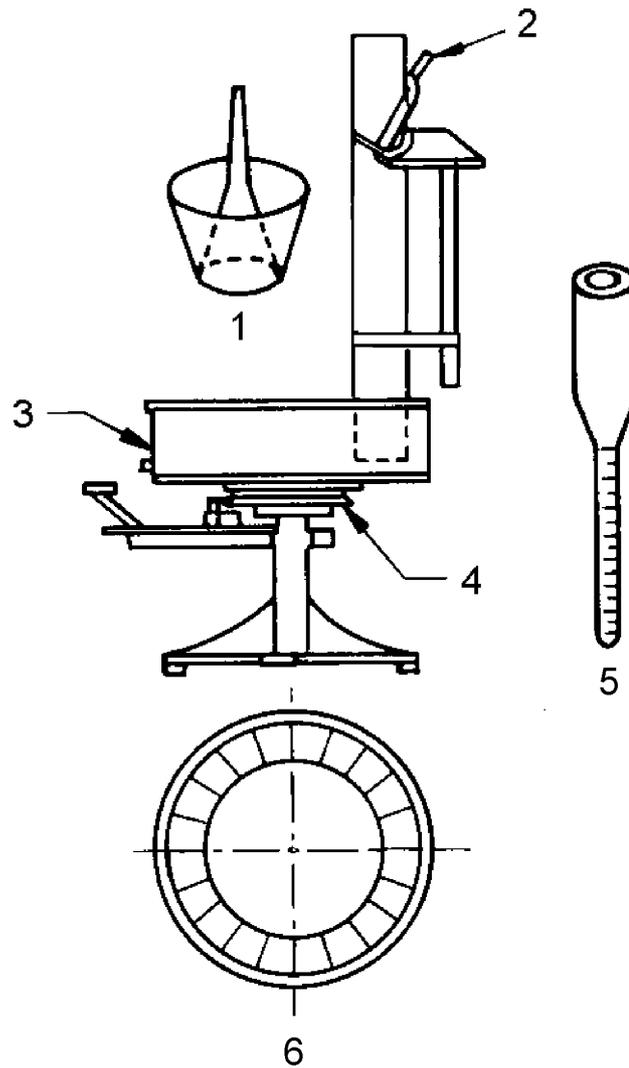

**Key**

- 1 dropping device
- 2 lever
- 3 aluminium trough
- 4 iron stop spring
- 5 silt measuring tube
- 6 plan of trough with collecting box

**Figure E.2 — Essential features of a mechanical siltometer for sediment (0,06 mm to 0,60 mm)**

Table E.1 gives the deduced diameter of sediment particles settling through a vertical water column 2 m long for various times and at different temperatures.

**Table E.1 — Deduced diameter in micrometers of sediment particles settling through a 2 m vertical container in various times and at different temperatures (after Puri with Zahm's correction)**

Temperature °C	Time s																			
	26	30	34	38	42	46	50	54	58	62	66	76	86	96	106	136	166	196	376	566
10	618	541	483	438	401	371	346	325	307	291	277	249	227	209	195	165	146	131	91	74
11	612	536	478	433	397	367	342	322	303	287	274	246	224	207	193	163	144	130	90	73
12	606	530	473	429	393	363	339	317	300	284	271	243	221	204	190	161	142	128	88	72
13	600	525	468	427	389	360	335	314	297	281	268	240	219	202	188	159	140	126	87	71
14	594	520	464	421	385	356	332	311	294	278	265	237	217	200	186	157	138	125	86	70
15	588	515	459	416	381	353	328	308	290	275	262	235	214	198	184	155	137	123	85	69
16	583	510	455	412	378	349	325	305	287	272	259	232	212	196	182	153	135	122	84	68
17	577	55	451	408	374	346	322	302	285	270	256	230	209	193	180	152	134	120	83	67
18	572	501	446	404	370	342	319	299	282	267	254	228	207	191	178	150	132	119	82	66
19	567	496	443	400	367	339	315	296	279	264	251	225	205	189	176	148	130	118	81	66
20	562	492	438	397	363	336	312	293	276	262	249	223	203	187	174	147	129	116	80	65
21	557	487	435	393	360	333	310	290	274	259	246	221	201	185	172	145	127	115	79	64
22	553	484	431	390	357	330	307	288	271	257	244	219	199	183	171	144	126	114	78	63
23	548	480	428	386	354	327	304	285	268	254	242	217	197	182	169	142	125	113	77	63
24	544	476	424	383	351	324	302	282	266	252	240	215	195	180	167	141	124	112	76	62
25	540	472	421	380	348	321	299	280	264	250	237	213	193	178	166	139	122	110	76	61
26	535	468	417	377	345	319	296	278	261	247	235	211	192	177	164	138	121	109	75	60
27	531	465	414	374	342	316	294	275	259	245	233	209	190	175	163	136	120	108	74	60
28	527	461	411	371	339	313	291	273	257	243	231	207	188	173	161	135	119	107	73	59
29	522	458	407	368	337	311	289	271	255	241	229	205	186	172	160	134	118	106	72	59
30	518	454	404	365	334	308	287	268	253	239	227	203	185	170	158	133	116	105	72	58
31	515	451	401	362	331	306	284	266	251	237	225	202	183	169	157	131	115	104	71	57
32	511	447	398	359	329	304	282	264	249	235	224	200	182	167	156	130	114	103	70	57
33	507	444	395	357	326	301	280	262	247	233	222	198	180	166	154	129	113	102	70	56
34	503	441	392	354	324	299	278	260	245	231	220	197	179	164	153	128	112	101	69	56
35	500	437	389	351	321	297	276	258	243	230	218	195	177	163	151	127	111	100	68	55

### E.3.3 Bottom-withdrawal tube method

**E.3.3.1** Bottom-withdrawal tubes are widely used for the analysis of sediment particles of diameter less than 0,5 mm.

They work on the Oden principle of uniform dispersion in sediment systems, which states that in a uniformly dispersed suspension (as used in the bottom-withdrawal tube), the sediment concentration at any level remains constant until the largest particle in suspension has had time to settle from the surface to the level in question.

The apparatus consists of a straight glass tube (see Figure E.3), 1 m long, having a uniform diameter of 25,4 mm. There is an outlet at the bottom, which makes possible the rapid withdrawal of material accumulated at the lower end of the tube.

The uniformity of the diameter of the bottom-withdrawal tube should be checked and the variation should not exceed  $\pm 1,5\%$  of the main value.

Proceed as follows.

Uniformly disperse the sample in the bottom-withdrawal tube, and then clamp in a vertical position. The solid particles begin to settle at the bottom, the settling velocity being a function of the relative density and size of individual particles.

Intermittently, withdraw fractions of the settled sediment from the bottom of the tube into containers (bottles), and place in a temperature-controlled oven at 85 °C to 95 °C until the sediment appears dry, then dry it at 101 °C to 105 °C to constant mass, then cool and weigh. (Withdrawals should be carried out after periods of time of corresponding to those required for particles of a given size to pass through the length of the water column. Each fraction is then dried and the mass of the accumulated sediment determined.)

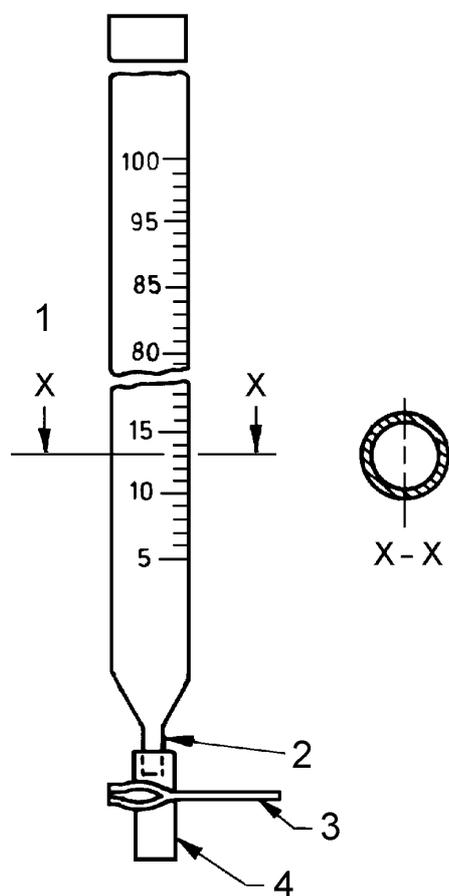

- Key**
- 1 depth, centimetres
  - 2 nozzle  $\left\{ \begin{array}{l} \varnothing_{\text{ext}} = 10 \text{ mm} \\ \varnothing_{\text{int}} = 7 \text{ mm} \end{array} \right.$
  - 3 pinch clamp
  - 4 rubber tube

Figure E.3 — Example of a bottom-withdrawal tube

The mass of sediment for each concentration that remains in suspension can be computed from these data, assuming that the water column has remained at the original height. Since the height of the water column actually decreases with each withdrawal, a *pro rata* correction has to be made to obtain the amount of suspended material that would remain in a column of constant height. Similarly, the theoretical settling time for each fraction in a column of constant height, can also be computed. The computed percentage of material remaining in suspension at the moment of withdrawal, relative to the total amount of material present in the original sample, together with the corresponding settling time, provide the data necessary to construct an Oden curve (see Figure E.4). Extending a tangent from any point on the curve to the ordinate scale will indicate the amount of material in the sample that is finer than the particle size represented on the corresponding time abscissa at the point of tangency. Graduation of the sediment according to any desired scale of particle sizes can be determined in this manner. Since the settling velocity is sensitive to temperature and changes in the medium, variations in temperature shall be considered in correlating particle sizes and settling time.

**E.3.3.2** Particular attention shall be given to the following procedures while conducting the test.

Before commencing the analysis, shake the bottom-withdrawal tube for about 5 min at intervals of approximately 5 s (which is approximately the time required for an air bubble to move from one end to the other).

Take care that the stopwatch is started only when the air bubble starts upwards from the bottom of the tube in the supporting stand.

Determine beforehand the time after which each fraction is to be taken, considering the time required to run off a column of liquid.

When reading the percentage particle-size distribution, draw two tangents, wherever possible, to allow cross-checking.

### **E.3.4 Visual-accumulation tube method**

#### **E.3.4.1 General**

This method is used for the analysis of sands (diameter 0,062 mm to 2 mm).

#### **E.3.4.2 Apparatus**

The apparatus consists of the main elements as described in E.3.4.2.1 to E.3.4.2.6 and as shown in Figure E.5).

**E.3.4.2.1 Glass funnel**, about 250 mm long, bearing a reference mark on the stem of the funnel indicating the proper height for the water.

**E.3.4.2.2 Rubber tube**, connecting the funnel and the main sedimentation tube, which, together with a special clamping mechanism, serves as a valve.

Details of the mechanism for clamping the rubber tube together are shown in Figure E.6.

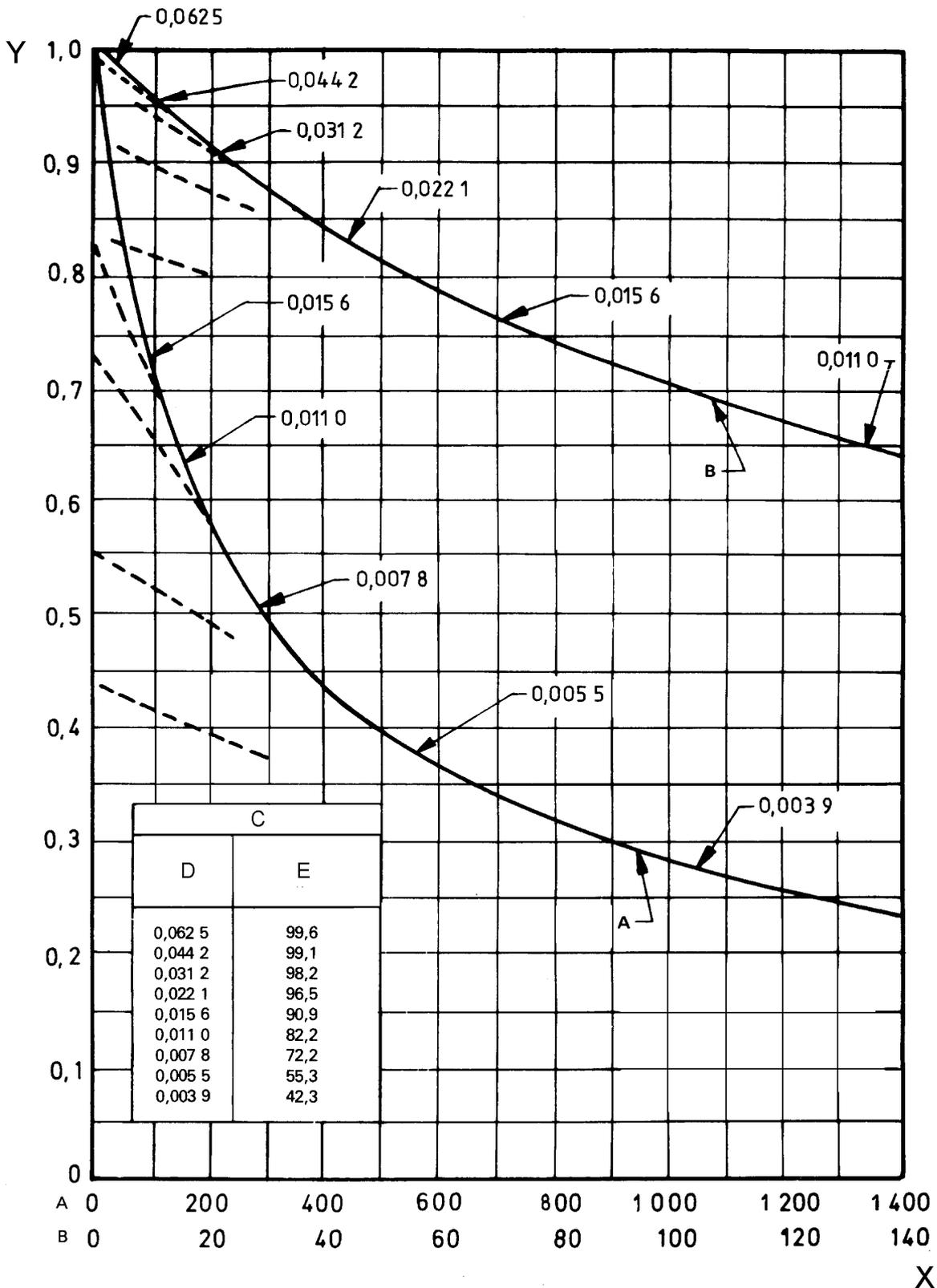

**Key**

- X time, expressed in minutes
- Y percentage of sample in suspension, 1 m depth
- NOTE Sample C 52m, Cedar river, station 80 5-6-42, temperature 26° C.
- A curve A
- B curve B
- C grading
- D size, millimetres
- E cumulative percentage of finer material

**Figure E.4 — Example of an Oden curve (constant depth, variable time)**

Licensed copy: Lee Shau Kee Library, HKUST, Version correct as of 03/01/2015, (c) The British Standards Institution 2013

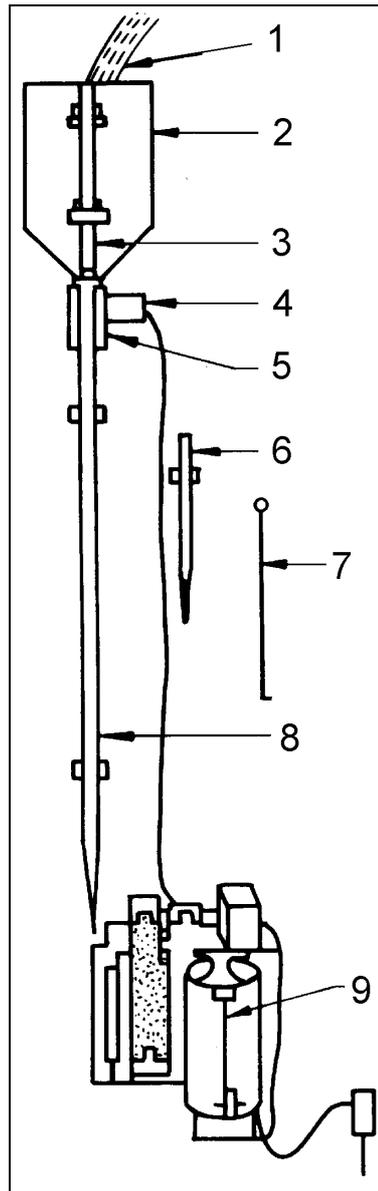

**Key**

- 1 distilled water
- 2 glass funnel (see E.3.4.2.1)
- 3 rubber tube (see E.3.4.2.2)
- 4 valve switch
- 5 valve mechanism
- 6 thermometer
- 7 mixing rod
- 8 glass tube (see E.3.4.2.3)
- 9 recorder (see E.3.4.2)

**Figure E.5 — Visual-accumulation tube**

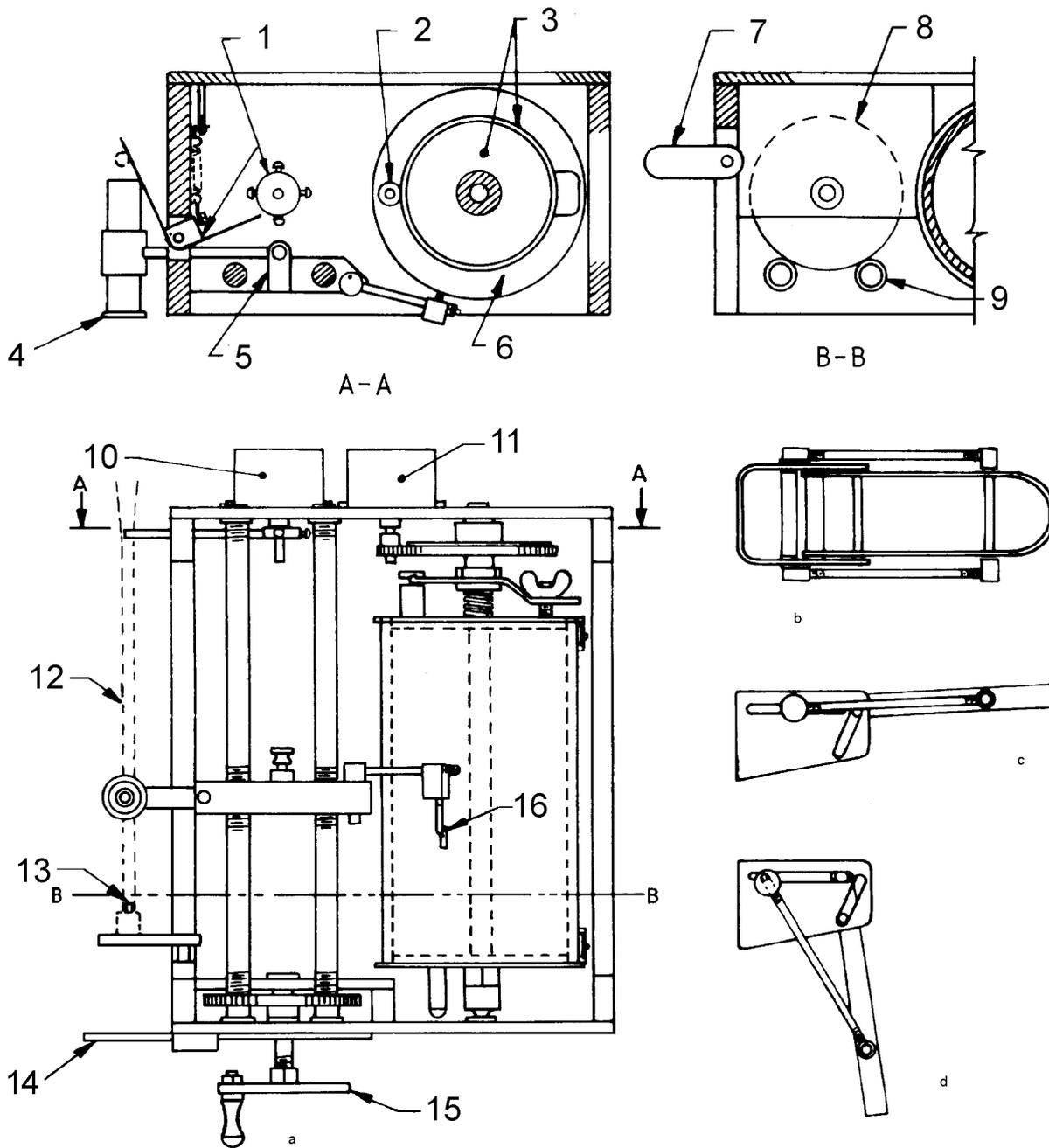

**Key**

- |                   |                 |
|-------------------|-----------------|
| 1 taper           | 9 small gear    |
| 2 clock gear      | 10 taper motor  |
| 3 gear and clutch | 11 timing motor |
| 4 eyepiece        | 12 visual tube  |
| 5 carriage        | 13 tube plug    |
| 6 chart cylinder  | 14 beaker shelf |
| 7 tube bracket    | 15 hand wheel   |
| 8 drive gear      | 16 pen          |

- |                              |
|------------------------------|
| a Elevation.                 |
| b Plan.                      |
| c Closed position elevation. |
| d Open position elevation.   |

**Figure E.6 — Visual-accumulation tube mechanisms**

**E.3.4.2.3 Glass sedimentation tube**, in either one of two lengths:

- a) A 1 800 mm tube has a section 1 400 mm long, with a 50 mm inside diameter, a 200 mm constricting section and a 200 mm accumulation section with a 10 mm inside diameter.

This long tube is used for the analysis of bed, beach or other coarse sands when a sufficient quantity of sample is available.

- b) A 1 200 mm tube has a section 800 mm long, with a 25 mm inside diameter, a 200 mm constricting section and a 200 mm accumulation section with an inside diameter of 2,1 mm, 3,4 mm, 5,0 mm or 7,0 mm.

The short tube is suitable for the analysis of samples that contain only small quantities of sand, most of which have a sieve diameter of less than 1 mm. An elastic plug is inserted into the bottom of the accumulation section.

**E.3.4.2.4 Electrically operated tapping mechanism**, which strikes against the glass tube and helps keep the accumulation of sediment uniformly packed and level on top.**E.3.4.2.5 Visual accumulation tube recorder**, composed of the following:

- a) carriage, which can be moved vertically by a hand-operated mechanism and on which are mounted a recording pen and an optical instrument consisting of a two-power telescope eyepiece with a horizontal cross hair;
- b) cylinder, which carries a chart and rotates at a constant rate during the analysis.

**E.3.4.2.6 Chart recorder**, incorporating the fall-diameter calibration, capable of drawing a continuous curve of the sediment accumulation on a paper chart.**E.3.4.3 Samples suitable for analysis**

Samples having particles that are mainly in the range of sand sizes are suitable for analysis by this method. The mass of sample may be as small as 0,050 g for fine sands, and as large as 15 g for samples with a normal particle-size distribution. If many coarse particles, of sieve diameter larger than 1 mm or 2 mm, are present in a sample, they should be removed by sieving. If a large concentration of clay or silt (smaller than 0,062 mm) is present in a sample, the fine material should be removed before analysis. Some coarse silt does not affect the accuracy of results, but appreciable quantities of silt require additional time for the analysis. The clay and silt fractions should be separated from the sand by sieving or by sedimentation processes, but the division need not be at a precise size.

NOTE The calibration of the tube is carried out with sand particles, that is, the particles having an irregular shape and for which the density of the sample is about 2 650 kg/m<sup>3</sup>, even though there might be many particles of higher and lower densities. For special particle shapes or samples with densities different from 2 650 kg/m<sup>3</sup>, accurate analyses might require special calibration.

**E.3.4.4 Preparation of samples for analysis**

Because most of the samples to be analysed by this method contain clays and silts, the separation of the sand-sized from the finer material prior to analysis is a basic problem. The more thoroughly the clays and silts are removed from the sample, the simpler and faster the analysis will be. Present methods of removing clays and silts are not entirely satisfactory and further investigation of the problem should be carried out with a view towards reducing the total time of analysis.

Two wet-sieving processes may be used to separate sands from the finer sizes. If separation is carried out using a 0,062 5 mm sieve, some particles with sieve diameters larger than 0,062 5 mm will pass the sieve but, partly because of incomplete sieving, many particles with sieve diameters much smaller than that size will be retained on the sieve. An accurate sedimentation analysis requires the identification of both the silt (sieve diameters smaller than 0,062 5 mm) retained by the sieve and also that the sand (sieve diameters coarser than 0,062 5 mm) in the fraction passed by the sieve. If the separation is carried out using a 0,050 mm sieve, very little sand will be passed and an accurate sedimentation analysis can be performed by combining

sedimentation analysis of the clay and silt in the passed fraction, with the visual-accumulation tube analysis of the retained fraction. However, the smaller the opening of the sieve, the more time-consuming and difficult the sieving process is.

The initial separation of sands from silts and clays may be carried out by another process using a sedimentation tube. The sample is introduced at the top of a tube and allowed to settle for the time that will permit, for the given water temperature and distance of fall, all the particles with sedimentation diameters greater than 0,062 5 mm to settle to the bottom of the column. The settled part of the sample may be analysed in the tube, and the part not settled may be analysed by any method appropriate for silts and clays. This type of separation allows accurate analyses, but the time for analysis in the tube may be undesirably long because some fine material may be present.

Sand particles should be thoroughly soaked in water before analysis so that every particle is completely wetted. They should be contained in not more than 40 ml of water at a temperature no lower than that of the water in the tube. Samples for analysis should be relatively free of organic matter and in such condition that the grains will fall as individual particles and not as aggregates.

If the organic matter in a sample is of sufficient quantity to decrease the accuracy of analysis, it will be visible in the sample and very obvious as the sample settles in the tube. Also, the presence of aggregates is noticeable through the eyepiece and a competent operator can recognize that the analysis is erroneous.

Whether particles fall individually can be determined in a beaker prior to analysis by stirring the immersed sample in a rapid circular motion for a few moments and then allowing the particles to settle and accumulate at the bottom of the container. If there is only a slight tendency to form aggregates, repeated washing by adding distilled water to the sample, stirring, allowing the settling and decanting the supernatant liquid will generally improve the settling characteristics.

Organic matter, which can be objectionable because of its volume or because it forms a binding agent for floccules, may be oxidized by adding a 6 % hydrogen peroxide solution to the sample contained in about 40 ml of water, using about 5 ml of solution per gram of dry sample. Thoroughly stir, mix and cover the container. If the oxidation is slow, or after it has slowed, heat the mixture to 95 °C and allow it to remain at that temperature. The sample can be stirred occasionally and more hydrogen peroxide added until the oxidation appears complete. Then, washing two or three times as described above adequately prepares the sample for analysis, except that it might be necessary to cool the sample.

The water in the tube should be frequently changed to avoid contamination from repeated analyses of treated samples. The contamination does not appear to alter the accuracy of the analyses, but if the sample is dried and weighed after analysis, the mass can be affected.

#### **E.3.4.5 Selection of tube size**

Before performing an analysis, it is necessary to choose the proper tube size for the given sample. Frequently, two or more sizes can be satisfactory.

The quantity of sand and the upper particle-size limit in a sample are used as guides in selecting the tube size. Table E.2 indicates the appropriate tube size based on the amount of sand and the particle-size range of a sample. If the pertinent characteristics of samples are not known from previous experience, the sample to be analysed can be compared with a set of synthetic samples. For example, a sample may be analysed in a 2,1 mm tube if its particle size is comparable to a synthetic sample containing 0,8 g of sand with a maximum particle size of 0,250 mm.

The maximum particle-size ranges shown in Table E.2 should not be exceeded by a significant percentage of the sample. The percentage of excess may be greater if the sample is small relative to the capacity of the tube or if the analysis of the coarser portion is not highly important.

Table E.2 — Guide to selection of correct tube size

Sample		Maximum particle size		Sedimentation tube	
Dry mass	Volume of sand	Sedimentation diameter	Sieve diameter	Length	Diameter
g	ml	mm	mm	mm	mm
0,05 to 0,8	0,03 to 0,5	0,250	0,250	1 200	2,1
0,4 to 2,0	0,2 to 1,2	0,350	0,400	1 200	3,4
0,8 to 4,0	0,5 to 2,4	0,500	0,600	1 200	5,0
1,6 to 6,0	1,0 to 4,0	0,700	1,000	1 200	7,0
5,0 to 15,0	3,0 to 9,0	—	2,000	1 800	10,0

Normally, the best results are obtained if the total height of accumulation in the bottom of the tube is between 25 mm and 100 mm. If a sample has a very limited size range, or if the material is predominately coarse, better results are obtained with a maximum height less than 100 mm. If a satisfactory tube size is not selected for the first analysis, the sample can be transferred to a tube of a different size. However, the choice of a suitable tube is not difficult because the usable limits of the respective tubes overlap considerably.

#### E.3.4.6 Method of analysis

##### E.3.4.6.1 General

Analyses can be performed in less than 10 min, if the particles in the sample have sedimentation diameters greater than 62  $\mu\text{m}$ . More time is required if silt is present in the sample. The recommended procedure is as given in E.3.4.6.2 to E.3.4.6.12.

**E.3.4.6.2** Choose a chart appropriate to the length of the tube and record the identity of the sample, the operator and an identification of the analysis. Place the chart on the cylinder.

Ensure that the baseline of the chart is parallel to the bottom of the cylinder so that the pen trace will be parallel to the baseline except when sediment is accumulating.

NOTE The 1 800 mm and the 1 200 mm tubes require different charts (see examples in Figures E.7 and E.8) because the sample particles settle through different distances.

**E.3.4.6.3** Set the recorder pen on the zero-accumulation zero-time lines of the chart. The pen should start to the right of the zero-time line and should be brought to the line by the motor-driven rotation of the cylinder.

**E.3.4.6.4** Adjust the recorder to bring the horizontal cross-hair in the eyepiece level with the top of the tube plug where the accumulation of sediment begins.

**E.3.4.6.5** When the apparatus, including the proper sedimentation section, has been assembled, fill the tube with distilled water to just above the valve. Measure and record the temperature of the water in the tube, and close the valve. It is not necessary to change the water after each analysis.

**E.3.4.6.6** Start the electrical tapping mechanism; this operation also engages an electrical switch at the valve so that rotation of the cylinder will start when the valve is opened.

**E.3.4.6.7** Wash the sand sample into the funnel above the closed valve with gravity-fed deionized or distilled water. Fill the funnel to the reference mark, and then stir the sample briskly for 10 s using a special stirring rod.

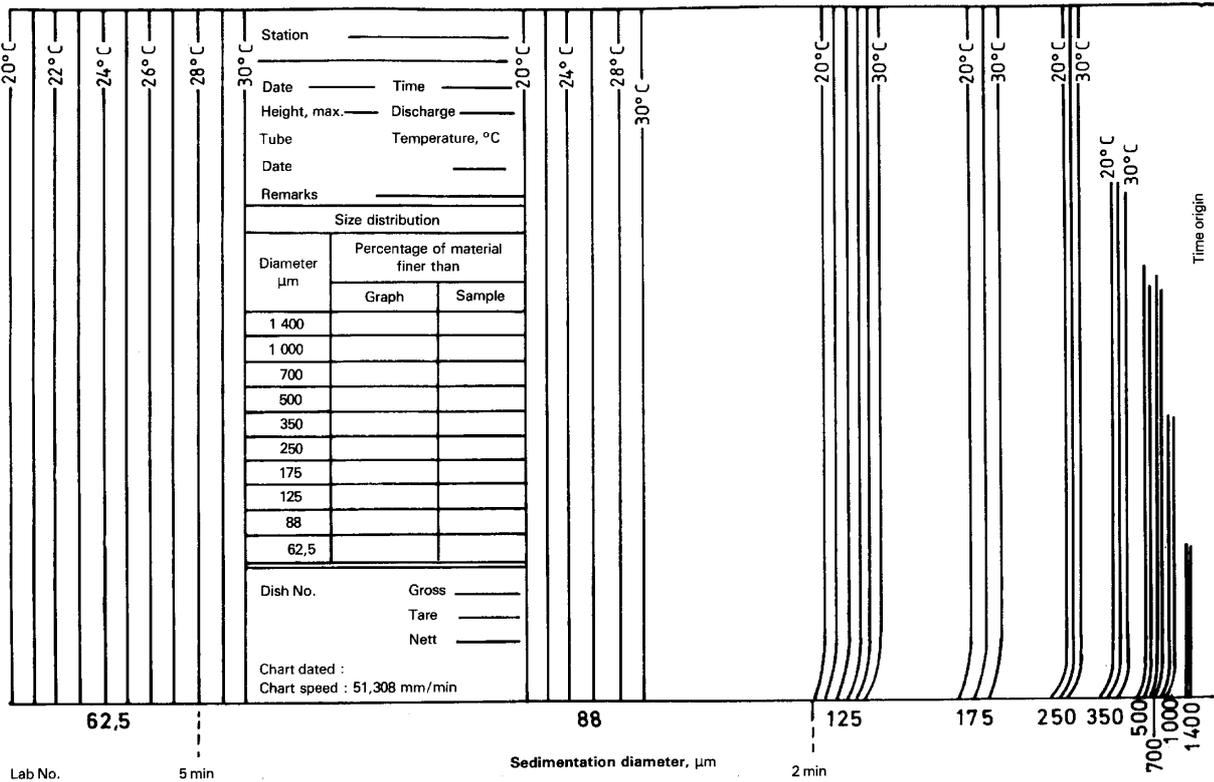

Figure E.7 — Calibrated chart for the analysis of sands by the visual-accumulation tube method using a 1 800 mm tube

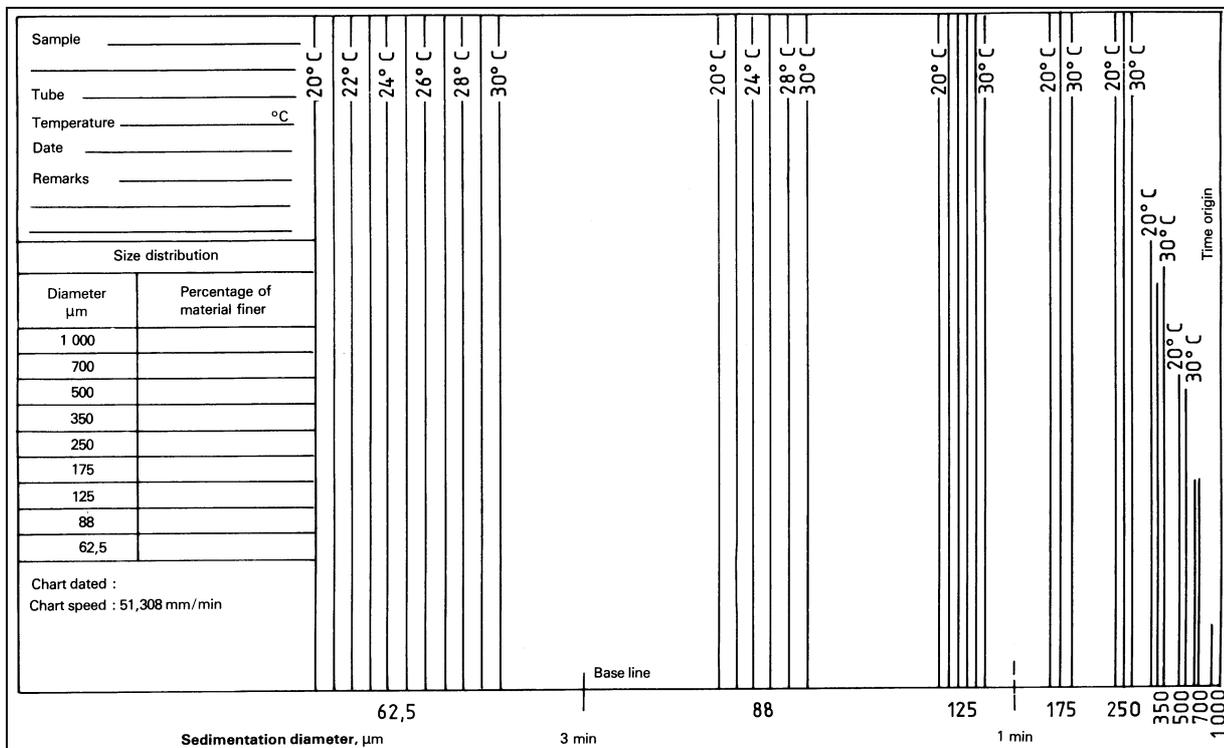

Figure E.8 — Calibrated chart for the analysis of sands by the visual accumulation tube method using a 1 200 mm tube

**E.3.4.6.8** Immediately open the valve fully. Because opening the valve automatically starts the cylinder, the chart time and the settling of the particles in the tube begin simultaneously.

**E.3.4.6.9** Look through the eyepiece and as soon as the first particles reach the bottom of the tube move the carriage vertically at a rate that keeps the horizontal cross-hair level with the level of the accumulation of sediment. Continue until the pen has passed the 62  $\mu\text{m}$  mark on the chart.

The rotation of the cylinder should stop automatically. If material is still settling, the tracking operation is continued, at least intermittently, until the maximum accumulation height is determined.

**E.3.4.6.10** While the pen is at the minimum accumulation height, release the cylinder-drive clutch and rotate the cylinder by hand to extend the line of maximum accumulation across the chart.

**E.3.4.6.11** When the valve has closed, drain the sample into a beaker by removing the tube plug. Open the valve slightly to drain out excess water and to wash out the lower end of the tube more completely with gravity-fed deionized or distilled water. Replace the plug.

**E.3.4.6.12** Determine the size distribution from the chart as follows.

The trace should be a continuous curve of sediment accumulation with time as the abscissa and the height of accumulated sediment as the ordinate. Generally, the analytical results are desired as percentages of the sample finer (or coarser) than a certain specific size. One common series of these sizes is shown on the calibrated chart (see Figures E.9 and E.10). The percentage of material finer than a specific size can be read from the chart by using a scale that will conveniently divide the total accumulation into 100 equal parts. The intersections of the accumulation curve and the division-size lines (interpolated, if need be) for the temperature of the analysis are marked by ticks.

Spread the chart out flat; place the "0 %" of the scale on the total-accumulation line and the "100 %" on the zero-accumulation line. Move the scale horizontally to the intersection of the curve with the size-temperature line. If horizontal lines instead of ticks are drawn through the intersections, all percentages can be read from one position of the scale. The percentage of material finer than a specified size can be read directly on the scale, as it is represented by the portion of the total accumulation that lies above the curve. Percentage contents of coarser material can be read by reversing the scale.

If material coarser than that analysed was removed from the sample before the analysis and this coarse material accounted for 10 % of the total sample, then the 90 % mark may be used on the zero-accumulation line to show readings directly in percentages of the total sample. Similarly, if 40 % of the original sample was removed as silt and clay before the analysis, the 60 % mark may be used on the total-accumulation line to obtain direct readings in percentages of the total sample.

### **E.3.5 Pipette method**

#### **E.3.5.1 General**

This method can be used for analysis of particles with a diameter less than 0,06 mm.

#### **E.3.5.2 Apparatus**

**E.3.5.2.1 Vertical glass jar**, about 2,5 l to 3 l capacity, diameter approximately 16 cm and height approximately 32 cm.

**E.3.5.2.2 Sedimentation tube**, narrow-mouth, 1 l graduated cylinder, with air-tight stopper (or rubber cork) used as sedimentation tube.

**E.3.5.2.3 Evaporating dishes**, porcelain, of approximately 50 ml and 125 ml capacity.

**E.3.5.2.4 Glass beakers**, 1 l and 250 ml capacity.

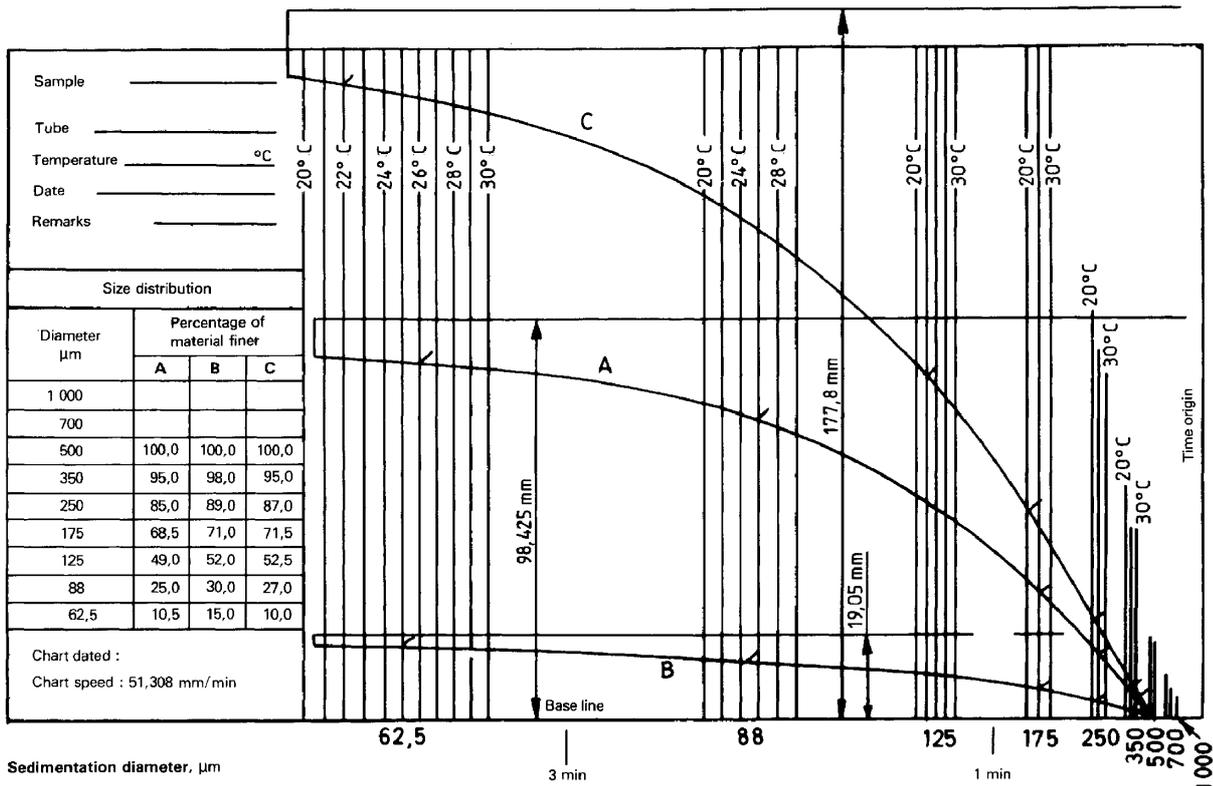

**Key**

- A Powder River sand, fine distribution, sample No. 7, 5,0 mm tube, 26° C
- B Powder River sand, fine distribution, sample No. 1, 2,1 mm tube, 25° C
- C Powder River sand, fine distribution, sample No. 9, 5,0 mm tube, 22° C

**Figure E.9 — Typical curves from a visual-accumulation tube analysis using a 1 200 mm tube**

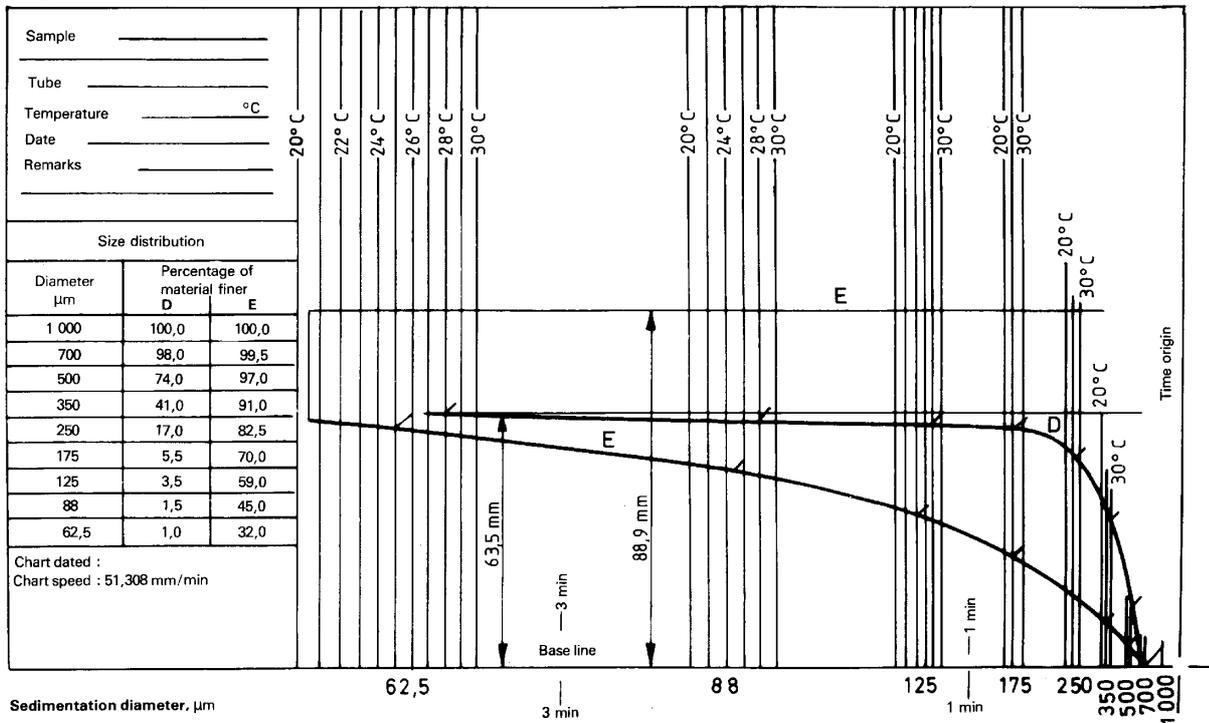

**Key**

- D Cheyenne River sand, sample No. 4, 7,0 mm tube, 28° C
- E Republican River sand, fine distribution, sample No. 2, 2,1 mm tube, 25° C

**Figure E.10 — Typical curves from a visual-accumulation tube analysis using a 1 200 mm tube**

**E.3.5.2.5 Withdrawal pipette**, long-stem with bulb, 20 ml capacity, marked at 10 cm on the stem from the lower end, capable of collecting fractions from 10 cm depth.

**E.3.5.2.6 Desiccator**.

**E.3.5.2.7 Sieve**, 200 mm diameter, capable of separating the coarser fractions from the finer fractions (see E.3.4.4).

**E.3.5.2.8 Volumetric flask**, 1 l capacity.

**E.3.5.2.9 Rimless glass or plastic container**, 60 ml to 80 ml volume, whose exact volume (i.e. capacity) shall be known or measured accurately.

**E.3.5.2.10 Glass funnel**, about 15 cm long, with a top diameter of approximately 8 cm.

**E.3.5.2.11 Wash bottle**.

**E.3.5.2.12 Bulb pipette**, 25 ml capacity.

**E.3.5.2.13 Stop watch**, with a resolution of 0,2 second or better.

**E.3.5.2.14 Polythene circular trough**, of approximately 40 cm diameter and 15 cm height.

**E.3.5.2.15 Thermometer**, capable of reading the temperature of the suspended mixture.

**E.3.5.2.16 Enamel plate or tray**, suitable for carrying evaporating dishes and to holding them in the drying oven.

**E.3.5.2.17 Tongs**, for handling hot dishes.

**E.3.5.2.18 Analytical balance**, capable of weighing accurately 0,001 g or less.

**E.3.5.2.19 Drying oven**.

### **E.3.5.3 Reagent**

Dispersing agent is made by dissolving 33 g of sodium hexametaphosphate and 7 g of sodium carbonate in distilled water to make 1 l of solution in a volumetric flask.

This solution is unstable and should be prepared at least once a month.

### **E.3.5.4 Samples**

#### **E.3.5.4.1 Samples suitable for analysis**

Samples composed of particles in the silt and clay range are suitable for analysis by this method. The coarser fraction should be separated by sieving and analysed by methods described earlier for coarser (i.e. greater than 0,06 mm) particles.

#### **E.3.5.4.2 Sample preparation**

##### **E.3.5.4.2.1 Wet sieving**

See E.2 and E.3.4.4 to ensure proper procedure of sieving and removal of organic matter, if required. See E.3.4.4, second paragraph, for wet sieving procedures to separate the sands from the finer portion.

Sieve approximately 100 g of properly mixed sample. Keep a polythene circular trough (E.3.5.2.14) below. Continue sieving till clear water passes through the sieve. Collect all the materials and water washings passing through the sieve in the trough.

Transfer the portion retained in the sieve (i.e. the coarser fraction) into a 250 ml beaker using a water stream from a wash bottle. Wash this portion with gravity-fed deionized or distilled water using the decantation method. Transfer all the washed particles into a dry, tared 125 ml porcelain dish. Keep the dish initially at 85 °C to 95 °C until the contents of the dish appear dry. Then, keep the dish in an oven at 101 °C to 105 °C overnight. Next day, cool the dish in a desiccator to room temperature. Weigh the dish with coarse particles. Find the mass of the coarse fraction present in the sample,  $m_{cf}$ . Use this material to analyse particle-size distribution of the coarser fractions (see E.2, E.3.3 and E.3.4).

#### E.3.5.4.2.2 Removal of salt

Transfer quantitatively the portion collected in the polythene trough (after passing through the sieve) into a vertical glass jar (E.3.5.2.1). Add distilled or deionized water to fill about 75 % of the jar. Stir the mixture with a glass rod to dissolve adhered salt. Allow the mixture to settle until the top portion of the water is clear. Siphon off the layer of clear water at the top and discard it. Again add distilled water to fill 50 % to 75 % of the jar. Stir and allow the suspension to settle. Siphon off the top clear water. Repeat the procedure until the particles do not settle or the water does not become clear within 1 h. By this procedure, most of the salt is removed. The jar now contains salt-free particles with about half the jar full of water. Mark the top level of the mixture; this is required to find the volume of the mixture afterwards (E.3.5.5.6).

#### E.3.5.5 Sample analysis

##### E.3.5.5.1 Concentration of the finer particles collected in the jar

Stir the mixture in the jar vigorously to make it homogeneous. Using a rimless plastic or glass container of known capacity,  $V_1$ , (E.3.5.2.9), quickly take out a container-full of the homogeneous mixture and pour the mixture into a dry, tared 125 ml porcelain dish (E.3.5.2.3). Repeat the procedure once again for a duplicate measurement, i.e. take another aliquot in a second tared porcelain dish. Again, mark the top level of the mixture in the jar (i.e. a second mark). Dry the contents of the dishes at 85 °C to 95 °C until the contents of the dishes appear dry. Then, keep the dishes in an oven at 101 °C to 105 °C overnight. Cool the dishes in a desiccator. Weigh the dishes accurately. Compute the mass of the silt,  $m_{st1}$ , in the first dish by subtracting the tare mass,  $m_{d1}$ , of the dish from the mass,  $m_{d1,st1}$ , of the dish plus dried sample (silt). Calculate the mass,  $m_{st2}$ , of the silt in the second dish and average the two masses,  $\bar{m}_{st}$ . Calculate the concentration,  $C_{st}$ , of silt on a mass/volume basis in the homogeneous mixture by dividing the average mass,  $\bar{m}_{st}$ , by the volume of the mixture,  $V_1$ , taken in each porcelain dish.

This gives the mass,  $\bar{m}_{st}$ , and concentration,  $\bar{m}_{st}/V_1$ , of silt taken in the vertical jar.

##### E.3.5.5.2 Preparation of sample in sedimentation tube

In this method, a 1 l narrow-mouth graduated cylinder (E.3.5.2.2) is used as a sedimentation tube. In this procedure, the capacity of the sedimentation tube,  $V_2$  is 1 000 ml.

If the level of the mixture present in the vertical jar goes below the second marking due to evaporation loss, add distilled water to bring the level up to the second mark. Stir the mixture thoroughly to assure that it is homogeneous. After determining the mass,  $m_{stx}$  (where  $x$  is the number of the container), in grams, of the silt present in one of the containers (E.3.5.2.9) full of mixture, add the number of containers full of the mixture to the 1 l narrow-mouth graduated cylinder (to be used as a sedimentation tube; if necessary use a funnel for pouring in the mixture), so that the mass of silt in the cylinder amounts to between 5 g and 10 g. Record the number,  $N$ , of containers full of the mixture added to the graduated cylinder and calculate the actual mass,  $m_{st,a}$ , in grams, in accordance with Equation (E.3)

$$m_{st,a} = N \times m_{stx} \quad (\text{E.3})$$

Add 25 ml of dispersing agent (E.3.5.3). Make the volume up to 1 l by adding distilled water. Insert the airtight stopper (or cork). Shake the mixture by violent agitation continuously inverting the cylinder by hand for about 2 min. Keep the mixture overnight for the dispersing agent to act. Prepare and keep ready a sufficient number of 50 ml porcelain evaporating dishes (E.3.5.2.3), one for each fraction to be collected plus one for the blank correction. These dishes shall be properly cleaned, dried, accurately weighed (to the nearest to 0,001 g) and cooled to room temperature.

**EXAMPLE** If sample fractions are to be taken at three specified time intervals, to collect, for example, the 0,02 mm, 0,006 mm and 0,002 mm fractions (i.e. medium silt, fine silt and clay fractions respectively), keep four evaporating dishes ready; three for three fractions and one for blank correction. Number the dishes from one to three for three fractions and identify the fourth one as the blank.

#### **E.3.5.5.3 Starting the analysis**

Next day, record the temperature of the mixture. Keeping the cylinder stoppered, shake the contents vigorously by violent agitation and continually inverting the cylinder for about 2 min. Keep the cylinder on a horizontal flat surface. Zero time is the time when the agitation ceases. Record the time, start the stopwatch and remove the stopper.

#### **E.3.5.5.4 Collection of first fraction**

Seal the bulb end of a 20 ml bulb pipette (E.3.5.2.5) with the forefinger. To withdraw a fraction, slowly insert the sealed pipette vertically into the mixture without disturbing it until the 10 cm mark of the pipette stem coincides with the surface of the mixture. Use the other hand to keep the pipette in vertical position. Remove the forefinger from the bulb end of the pipette 10 s before the withdrawal time specified in Table E.3, which was prepared from Stokes' law for particles having an average relative density 2,65.

**EXAMPLE** From Table E.3, the withdrawal time for the collection of the 0,02 mm fraction at 25 °C for particles of relative density 2,65 is 247,8 s, i.e. approximately 4 min 8 s.

Apply suction uniformly to the withdrawal pipette. The rate of withdrawal should be such that 20 ml sample is withdrawn in approximately 20 s. Take care not to create any turbulence or agitation in the mixture. Fill the pipette up to the 20 ml mark. Seal it using the forefinger. Carefully take the pipette out and transfer the mixture quantitatively into the pre-weighed porcelain dish (E.3.5.5.4) number 1 kept ready for this purpose.

The sample may be removed with a pipette using suitable means.

A mechanical arrangement, such as a fixed-depth pipette may be used to lower the pipette vertically into the mixture and take it out after filling.

To transfer quantitatively all the particles from the pipette to porcelain dish, rinse the pipette with a small volume of gravity-fed deionized or distilled water and transfer the washings into the dish.

It is advisable not to withdraw the first fraction too early, preferably not during the first 1 min. If the particles are not at rest at zero time, an error can be introduced if the first fraction is taken too early. In case it is required to collect the 0,06 mm or 0,05 mm size fractions, then the depth of collection should be increased such that these fractions can be collected after 1 min. The time for collecting such a fraction from a greater depth can be computed from the Stokes' law equation (see E.3.1.5).

#### **E.3.5.5.5 Collection of next and subsequent fractions**

Based on the times given in Table E.3, collect the next and subsequent required/desired fractions following the procedure as specified in E.3.5.5.4.

**EXAMPLE** The withdrawal times for the collection of the 0,006 mm and the 0,002 mm fractions at 25 °C for particles with a relative density of 2,65 are 45,9 min (i.e. 45 min and 54 s) and 6,88 h (i.e. 6 h, 52 min and 48 s), respectively.

Collect the fractions in the respectively numbered dishes. Depending upon requirement or choice, fractions of different-sized particles are collected at the respective time intervals. The particles collected in these fractions will have a diameter equal to and less than the specified diameter.

When multiple samples are analyzed simultaneously, the starting, e.g. zero, time for each sample should be decided carefully, so that collection time for one fraction of one sample does not coincide with the collection time of any fraction of any other sample, and a sufficient time gap is allowed to collect all the fractions carefully without disturbing any of the mixtures.

Fractions up to 0,002 mm fractions can be collected in one day. If time does not permit the collection of all the desired or required fractions in one day, collection of finer fractions can be carried out on the next or subsequent day, following the collection timings as given in Table E.3. However, due to the displacement of water by the settling particles, the water tends to rise up the walls of the sedimentation tube and dissipate itself as convection currents at the top of the sedimentation column, carrying with it some of the finer particles. This leads to an excess of fines at the top of the tube and an over-estimation of the fines percentage in an analysis. For to this reason, the centrifugal method is considered to be more accurate for the analysis of very fine, less than 0,002 mm diameter particles.

#### E.3.5.5.6 Determination of the masses of individual fractions

Place the dishes containing sample fractions on an enamel tray or plate. Keep the plate in an oven at 105 °C overnight. Next day, take the plate out and transfer the dishes to a desiccator with the help of tongs. Allow the dishes to cool to room temperature. Weigh the dishes quickly to the nearest 0,001 g. Compute the mass of each individual fraction by subtracting the mass of the empty dish from the mass of the dish plus the dried solid fractions.

Each value is corrected for the dispersing reagent (blank correction). For the blank correction, take 25 ml of the dispersing agent (E.3.5.3) in a 1 l volumetric flask. Add distilled water to make the volume up to 1 l. Shake the mixture thoroughly to make it homogeneous. After about one hour, take 20 ml of the diluted solution of the dispersing agent in a pre-weighed 50 ml capacity porcelain dish kept for blank correction purpose (E.3.5.5.2). Dry the content of the dish in an oven overnight at 101 °C to 105 °C. Cool the dish to room temperature in a desiccator. Weigh the dish quickly to the nearest 0,001 g. Subtract the mass of the empty dish from this value. This will give the mass of the dispersing agent present in 20 ml of the diluted solution. Subtract this value from the mass of each individual fraction determined above. This will give corrected mass for each individual fraction. Designate the corrected mass, expressed in grams, of each individual fraction as  $m_{fr,i}$ , where  $i$  indicates the fraction number.

Empty the vertical jar (which was used in E.3.5.4.2.2) and wash with water. Fill the jar with water up to the first mark, i.e. the mark for the upper level of the mixture taken in it. Measure the volume,  $V_3$ , in millilitres, of the water in the vertical jar using a measuring cylinder; this equals the volume of the silt-water mixture taken in the jar. From the concentration, in grams per millilitre, of silt taken in the vertical jar (equal to  $\bar{m}_{st}/V_1$ , as determined in E.3.5.5.1) and volume,  $V_3$ , of the mixture in the jar as determined in this subclause, calculate the total silt content,  $m_{st,T}$ , in grams, in the mixture taken in the jar in accordance with Equation (E.4):

$$m_{st,T} = (V_3 \times \bar{m}_c) / V_1 \quad (\text{E.4})$$

This gives a total mass of the finer portion of the sample grams.

From the mass of the coarser portion of the sample,  $m_{cf}$ , expressed in grams (E.3.5.4.2.1), calculate the total mass,  $m_T$ , expressed in grams, of the sample taken for the particle-size analysis in accordance with Equation (E.5):

$$m_T = m_{st,T} + m_{cf} \quad (\text{E.5})$$

Table E.3 — Rate of settling of particles at various temperatures<sup>a</sup>

Temperature	Diameter mm																		
	0,001	0,002	0,003	0,004	0,005	0,006	0,07	0,008	0,009	0,01	0,02	0,03	0,04	0,05	0,06	0,07	0,08	0,09	0,10
	Time expressed in																		
	h					min					s								
(1)	(2)	(3)	(4)	(5)	(6)	(7)	(8)	(9)	(10)	(11)	(12)	(13)	(14)	(15)	(16)	(17)	(18)	(19)	(20)
10	40,41	10,10	4,49	2,53	97,0	67,4	49,5	37,9	29,9	24,2	363,7	161,7	90,9	58,2	40,4	29,7	22,7	18,0	14,5
11	39,30	9,83	4,37	2,46	94,3	65,5	48,1	36,8	29,1	23,6	353,7	157,2	88,4	56,6	39,3	28,9	22,1	17,5	14,1
12	38,19	9,55	4,24	2,39	91,7	63,6	46,8	35,8	28,3	22,9	343,7	152,8	85,9	55,0	38,2	28,1	21,5	17,0	13,7
13	37,17	9,29	4,13	2,32	89,2	61,9	45,5	34,8	27,5	22,3	334,7	148,7	83,6	53,5	37,2	27,3	20,9	16,5	13,4
14	36,15	9,04	4,02	2,26	86,8	60,2	44,3	33,9	26,8	21,7	325,3	144,6	81,3	52,1	36,1	26,6	20,3	16,1	13,0
15	35,22	8,80	3,91	2,20	84,5	58,7	43,1	33,0	26,1	21,1	317,0	140,9	79,2	50,7	35,2	25,9	19,8	15,7	12,7
16	34,29	8,57	3,81	2,14	82,3	57,2	42,0	32,1	25,4	20,6	308,6	137,2	77,2	49,4	34,3	25,2	19,3	15,2	12,3
17	33,43	8,36	3,71	2,09	80,2	55,7	40,9	31,3	24,8	20,1	300,8	133,7	75,2	48,1	33,4	24,6	18,8	14,9	12,0
18	32,56	8,14	3,62	2,04	78,1	54,3	39,9	30,5	24,1	19,5	293,0	130,2	73,3	46,9	32,6	23,9	18,3	14,5	11,7
19	31,76	7,94	3,53	1,98	76,2	52,9	38,9	29,8	23,5	19,1	285,8	127,0	71,5	45,7	31,8	23,3	17,9	14,1	11,4
20	30,98	7,75	3,44	1,94	74,4	51,6	37,9	29,0	23,0	18,6	278,8	123,9	69,7	44,6	31,0	22,8	17,4	13,8	11,2
21	30,24	7,56	3,36	1,89	72,6	50,4	37,0	28,3	22,4	18,1	272,1	121,0	68,0	43,5	30,2	22,2	17,0	13,4	10,9
22	29,52	7,38	3,28	1,85	70,9	49,2	36,2	27,7	21,9	17,7	265,7	118,1	66,4	42,5	29,5	21,7	16,6	13,1	10,6
23	28,83	7,21	3,20	1,80	69,2	48,1	35,3	27,0	21,4	17,3	259,5	115,3	64,9	41,5	28,8	21,2	16,2	12,8	10,4
24	28,17	7,04	3,13	1,76	67,6	47,0	34,5	26,4	20,9	16,9	253,6	112,7	63,4	40,6	28,2	20,7	15,8	12,5	10,1
25	27,53	6,88	3,06	1,72	66,1	45,9	33,7	25,8	20,4	16,5	247,8	110,1	61,9	39,6	27,5	20,2	15,5	12,2	9,9
26	26,92	6,73	2,99	1,68	64,6	44,9	33,0	25,2	19,9	16,2	242,3	107,7	60,6	38,8	26,9	19,8	15,1	12,0	9,7
27	26,32	6,58	2,92	1,65	63,2	43,9	32,2	24,7	19,5	15,8	236,9	105,3	59,2	37,9	26,3	19,3	14,8	11,7	9,5
28	25,75	6,44	2,86	1,61	61,8	42,9	31,5	24,1	19,1	15,4	231,7	103,0	57,9	37,1	25,7	18,9	14,5	11,4	9,3
29	25,19	6,30	2,80	1,57	60,5	42,0	30,9	23,6	18,7	15,1	226,8	100,8	56,7	36,3	25,2	18,5	14,2	11,2	9,1
30	24,66	6,16	2,74	1,54	59,2	41,1	30,2	23,1	18,3	14,8	221,9	98,6	55,5	35,5	24,7	18,1	13,9	11,0	8,9
31	24,14	6,04	2,68	1,51	57,9	40,2	29,6	22,6	17,9	14,5	217,3	96,6	54,3	34,8	24,1	17,7	13,6	10,7	8,7
32	23,65	5,91	2,63	1,48	56,7	39,4	29,0	22,2	17,5	14,2	212,8	94,6	53,2	34,0	23,6	17,4	13,3	10,5	8,5
33	23,16	5,79	2,57	1,45	55,6	38,6	28,4	21,7	17,2	13,9	208,5	92,7	52,1	33,4	23,2	17,0	13,0	10,3	8,3
34	22,70	5,67	2,52	1,42	54,5	37,8	27,8	21,3	16,8	13,6	204,3	90,8	51,1	32,7	22,7	16,7	12,8	10,1	8,2
35	22,24	5,56	2,47	1,39	53,4	37,1	27,2	20,9	16,5	13,3	200,2	89,0	50,1	32,0	22,2	16,3	12,5	9,9	8,0

<sup>a</sup> For an average relative density of 2,65.

### E.3.5.6 Calculations

Calculate the cumulative percentage,  $p_{\text{cum}}$ , of the finer fractions with respect to the whole sample (i.e. fine plus coarse part) from Equation (E.6):

$$p_{\text{cum}} = \frac{m_{\text{fr},i} \times V_2}{V_i \times m_{\text{st},a}} \times \frac{m_{\text{st},a}}{m_{\text{T}}} \times 100 \quad (\text{E.6})$$

where

$m_{\text{fr},i}$  is corrected mass, in grams, of the individual fractions (see E.3.5.5.6);

- $V_2$  is volume, in millilitres, of sample in sedimentation tube (see E.3.5.5.2; equal to 1 000 ml in the present procedure);
- $V_i$  is volume, in millilitres, of the individual fractions (see E.3.5.5.4; in the present procedure  $V_i = 20$  ml);
- $m_{st,a}$  is the mass, in grams, of silt taken in sedimentation tube (i.e. measuring cylinder; see E.3.5.5.2);
- $m_{st,T}$  is the mass, in grams, of the finer portion of the sample taken in vertical jar (see E.3.5.5.6);
- $m_T$  is the total mass, in grams, of the sample taken for purpose of particle size analysis (see E.3.5.5.6);

NOTE To analyse the particle-size distribution of silt and clay by the pipette method for samples having a relative density other than 2,65 or to analyse at a temperature higher than 35 °C, use Stoke's law [Equation (E.1)] to calculate the appropriate times to collect fractions from a depth of 10 cm or some other suitable depth.

## Annex F (normative)

### Determination of the relative density of sediment

#### F.1 Procedure

**F.1.1** Dry the sample in a drying oven at a temperature of 101 °C to 105 °C until a reasonably constant mass is obtained. Allow it to cool in a desiccator and store it there until required for the determination.

**F.1.2** Wash a density bottle (or pycnometer) of suitable size (e.g. 10 cm<sup>3</sup> or 25 cm<sup>3</sup>) with gravity fed deionized or distilled water. Fill it completely with distilled water at room temperature; record the temperature to the nearest 0,1 °C. Insert the stopper and wipe off any superfluous water, dry the outside with lens cleaning paper or chamois leather. During the procedure, ensure that no air bubbles are present. Weigh it to at least the nearest 1 mg and record the mass of the density bottle (or pycnometer) filled with distilled water as  $m_{p,dw}$ .

This procedure (filling and weighing) should be performed accurately and rapidly.

**F.1.3** Take out the stopper and empty the density bottle. Dry the bottle and stopper in an oven at 101 °C to 105 °C until a reasonably constant mass is obtained. Cool the density bottle and its stopper to room temperature. Insert the stopper and then accurately weigh the bottle to at least the nearest 1 mg. Repeat this procedure until a constant mass is obtained. Record the mass of the empty density bottle as  $m_p$ .

**F.1.4** Open the stopper. Add about 2 g to 5 g of dry sediment to the density bottle. Insert the stopper. Wipe off any particles from the outer surface of the density bottle. Weigh and record the mass of the density bottle partially filled with the sample as  $m_{p,sp}$ .

**F.1.5** Open the stopper. Fill the partially filled density bottle completely with distilled water by means of a pipette. Insert the stopper, wipe off the superfluous water, dry the outside with lens-cleaning paper or chamois leather, weigh accurately and record the mass of the density bottle filled with sample plus distilled water as  $m_{dw,s}$ .

#### F.2 Expression of results

Calculate the relative density,  $\rho_{rel}$ , from the formula:

$$\rho_{rel} = \frac{m_{p,s} - m_p}{(m_{p,s} - m_p) - (m_{dw,s} - m_{p,dw})} \quad (F.1)$$

where

$m_p$  is the mass of the density bottle (or pycnometer) (see F.1.3);

$m_{p,dw}$  is the mass of the density bottle filled with distilled water (see F.1.2);

$m_{p,s}$  is the mass of the density bottle partially filled with the sample (see F.1.4);

$m_{dw,s}$  is the mass of the density bottle filled with distilled water plus sample (see F.1.5).

## Annex G (normative)

### Determination of the particle-size distribution characteristics

#### G.1 General

Obtaining summary information on particle-size distribution characteristics involves the estimation of certain descriptive statistics that are representative of the data for which frequency-distribution tables have been prepared (see 8.3.1). The most important of such statistics are the mean, epitomizing the central tendency, and the standard deviation, embodying the variability of particle sizes.

#### G.2 Determination of particle-size characteristics

##### G.2.1 Arithmetic-mean particle diameter

A commonly used measure of the central tendency is the arithmetic mean,  $\bar{D}$ . It is the sum of the values recorded in a series divided by the number of values. A grouped distribution is described by Equation (G.1):

$$\bar{D} = \frac{\sum p_i D_i}{\sum p_i} \quad (\text{G.1})$$

where

$D_i$  is the mid-value of class interval  $i$ ;

$p_i$  is the percentage of the mass of the sample in the  $i$ th class interval.

##### G.2.2 Geometric-mean particle diameter

Since the particle-size distribution of bed material is most often lognormal, the location parameter is the mean of  $\lg D_g$  and the estimation is given by Equation (G.2):

$$\lg D_g = \frac{\sum p_i \lg D_i}{\sum p_i} \quad (\text{G.2})$$

where the parameters are the same as for Equation (G.1).

##### G.2.3 Median

The median, usually denoted by  $D_{50}$ , is another measure of central location, widely used to represent the general nature of the particle size of samples.  $D_{50}$  is that diameter for which the aggregate mass of all particles smaller than this size is 50 % of the total mass. The median is a convenient measure of the central tendency of particle-size data for which a cumulative percentage curve is available. In practice,  $D_{50}$  can be obtained from the cumulative curve as the  $x$  coordinate of the point on curve with a  $y$  coordinate of 50 %.

### G.2.4 Percentile points

Other percentiles entering into the concepts of bed-load motion are  $D_{10}$ ,  $D_{35}$ ,  $D_{65}$  and  $D_{90}$ . These percentile points may be obtained in a manner analogous to that for the median:  $D_{65}$  and  $D_{35}$  represent the particle diameter for which 65 % by mass and 35 % by mass, respectively, of the total sample is finer.

### G.2.5 Example of determination of particle-size distribution characteristics

The procedures for computing some of the location parameters are partially set out in Table G.1.

The geometric mean particle diameter,  $D_g$ , is given by Equation (G.3):

$$D_g = \text{Antilg} (-44,503 \ 3/100) \quad (\text{G.3})$$

$$= 0,359 \text{ mm}$$

The mean particle diameter,  $\bar{D}$ , is given by Equation (G.4):

$$\bar{D} = 43,96/100 \quad (\text{G.4})$$

$$= 0,44 \text{ mm}$$

**Table G.1 — Computation of geometric mean diameter and arithmetic mean diameter**

Size range mm	Percent of mass of the sample $p_i$	$D_i$ mm	$\lg D_i$	$p_i D_i$	$p_i \lg D_i$
4 to 2	0,5	3,0	0,477 1	1,50	0,238 6
2 to 1	5,6	1,5	0,176 1	8,40	0,986 2
1 to 0,5	11,7	0,75	-0,124 9	8,78	-1,461 3
0,5 to 0,25	53,7	0,375	-0,426 0	20,14	-22,876 2
0,25 to 0,125	26,4	0,187	-0,728 2	4,94	-19,224 5
0,125 to 0,062 5	2,1	0,093	-1,031 5	0,20	-2,166 1
				$\Sigma p_i D_i$	$\Sigma p_i \lg D_i$
				43,96	-44,503 3

### G.3 Determination of the standard deviation

**G.3.1** The parameter most commonly used to characterize a particle-size distribution is the standard deviation, which is the square root of the average of squares of the deviations from the mean, as given in Equation (G.5):

$$s_D = \sqrt{\frac{\sum (D_i - \bar{D})^2 p_i}{\sum p_i}} \quad (\text{G.5})$$

The variance of  $\lg D$ , namely  $\sigma^2$ , may be estimated from Equation (G.6):

$$\sigma^2 = \frac{1}{(n-1)} \sum_{i=1}^n (\lg D_i - \lg D_g)^2 \tag{G.6}$$

where  $\sigma$  is the standard deviation of  $\lg D$ .

Since the particle-size distribution is more often lognormal, an approximation of the standard deviation,  $S_{Dg}$ , of the particle-size value, based on a standard normal probability curve, can be expressed as shown in Equation (G.7):

$$S_{Dg} = \frac{1}{2}(D_{84} - D_{16}) \tag{G.7}$$

where

$D_{84}$  is that diameter for which the aggregate mass of all particles smaller than this size is 84 % of the total mass;

$D_{16}$  is that diameter for which the aggregate mass of all particles smaller than this size is 16 % of the total mass.

These values can be obtained (approximately) by interpolating from column 2 of Table 6. Alternatively, estimates of  $D_{84}$  and  $D_{16}$  can also be obtained from the particle-size distribution curve plotted on lognormal paper (see, for example, Figure 15, which is based on another set of data), and which in turn can be used for computing standard deviation.

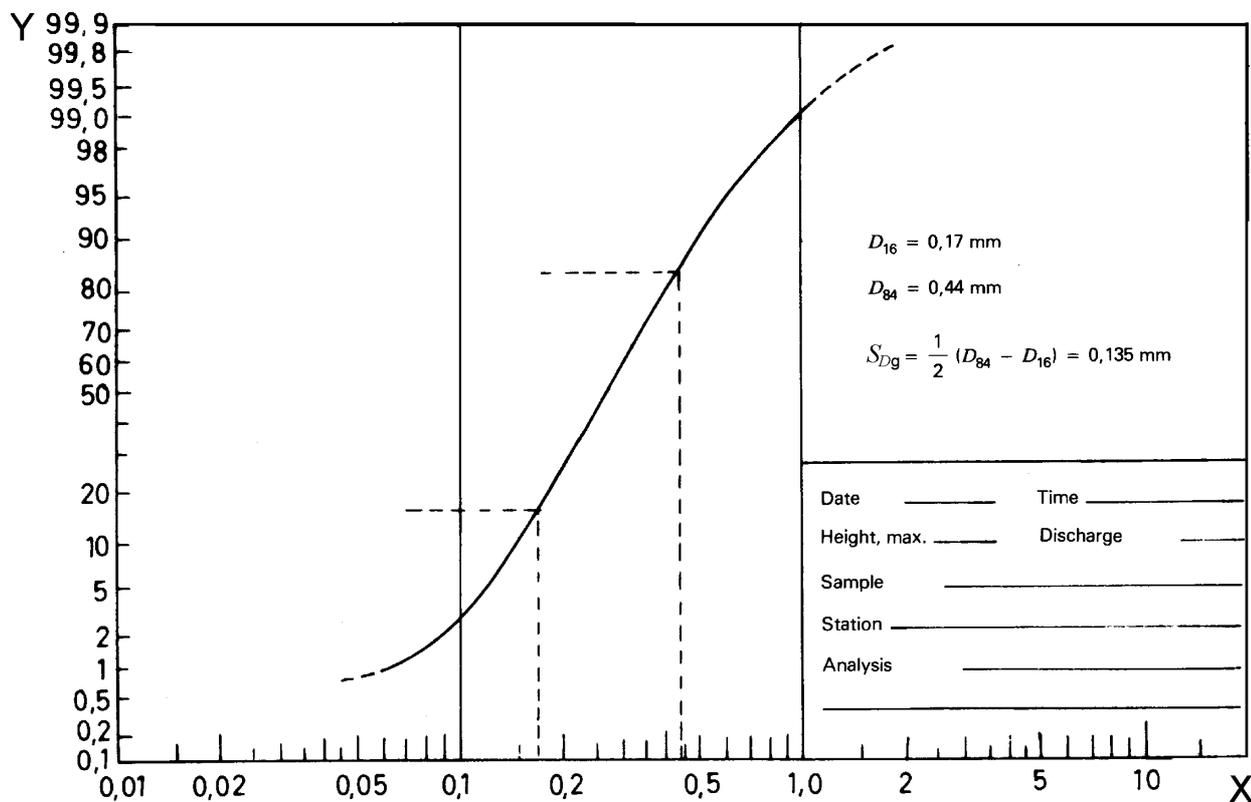

**Key**

- X diameter, expressed in millimetres
- Y mass percentage finer than

**Figure G.1 — Determination of percentile points and geometric standard deviation**

## Bibliography

- [1] CRC Handbook of Chemistry and Physics, Ed. Robert C. Weast and Associate Editor Malvin J. Astle, Publication: CRC Press Inc., Florida, USA

NOTE For viscosity and density values of water at different temperatures.

---

---

# BSI — British Standards Institution

BSI is the independent national body responsible for preparing British Standards. It presents the UK view on standards in Europe and at the international level. It is incorporated by Royal Charter.

## Revisions

British Standards are updated by amendment or revision. Users of British Standards should make sure that they possess the latest amendments or editions.

It is the constant aim of BSI to improve the quality of our products and services. We would be grateful if anyone finding an inaccuracy or ambiguity while using this British Standard would inform the Secretary of the technical committee responsible, the identity of which can be found on the inside front cover. Tel: +44 (0)20 8996 9000. Fax: +44 (0)20 8996 7400.

BSI offers members an individual updating service called PLUS which ensures that subscribers automatically receive the latest editions of standards.

## Buying standards

Orders for all BSI, international and foreign standards publications should be addressed to Customer Services. Tel: +44 (0)20 8996 9001. Fax: +44 (0)20 8996 7001. Email: [orders@bsi-global.com](mailto:orders@bsi-global.com). Standards are also available from the BSI website at <http://www.bsi-global.com>.

In response to orders for international standards, it is BSI policy to supply the BSI implementation of those that have been published as British Standards, unless otherwise requested.

## Information on standards

BSI provides a wide range of information on national, European and international standards through its Library and its Technical Help to Exporters Service. Various BSI electronic information services are also available which give details on all its products and services. Contact the Information Centre. Tel: +44 (0)20 8996 7111. Fax: +44 (0)20 8996 7048. Email: [info@bsi-global.com](mailto:info@bsi-global.com).

Subscribing members of BSI are kept up to date with standards developments and receive substantial discounts on the purchase price of standards. For details of these and other benefits contact Membership Administration. Tel: +44 (0)20 8996 7002. Fax: +44 (0)20 8996 7001. Email: [membership@bsi-global.com](mailto:membership@bsi-global.com).

Information regarding online access to British Standards via British Standards Online can be found at <http://www.bsi-global.com/bsonline>.

Further information about BSI is available on the BSI website at <http://www.bsi-global.com>.

## Copyright

Copyright subsists in all BSI publications. BSI also holds the copyright, in the UK, of the publications of the international standardization bodies. Except as permitted under the Copyright, Designs and Patents Act 1988 no extract may be reproduced, stored in a retrieval system or transmitted in any form or by any means – electronic, photocopying, recording or otherwise – without prior written permission from BSI.

This does not preclude the free use, in the course of implementing the standard, of necessary details such as symbols, and size, type or grade designations. If these details are to be used for any other purpose than implementation then the prior written permission of BSI must be obtained.

Details and advice can be obtained from the Copyright & Licensing Manager. Tel: +44 (0)20 8996 7070. Fax: +44 (0)20 8996 7553. Email: [copyright@bsi-global.com](mailto:copyright@bsi-global.com).