

BS ISO 4359:2013



BSI Standards Publication

# Flow measurement structures — Rectangular, trapezoidal and U-shaped flumes

**bsi.**

...making excellence a habit.™

**National foreword**

This British Standard is the UK implementation of ISO 4359:2013. It supersedes BS ISO 4359:1983 which is withdrawn.

The UK participation in its preparation was entrusted to Technical Committee CPI/113/2, Flow measurement structures.

A list of organizations represented on this committee can be obtained on request to its secretary.

This publication does not purport to include all the necessary provisions of a contract. Users are responsible for its correct application.

© The British Standards Institution 2013. Published by BSI Standards Limited 2013

ISBN 978 0 580 70395 9

ICS 17.120.20

**Compliance with a British Standard cannot confer immunity from legal obligations.**

This British Standard was published under the authority of the Standards Policy and Strategy Committee on 28 February 2013.

**Amendments issued since publication**

Date	Text affected
------	---------------

---

INTERNATIONAL  
STANDARD

**ISO**  
**4359**

Second edition  
2013-02-15

---

---

**Flow measurement structures —  
Rectangular, trapezoidal and  
U-shaped flumes**

*Structures de mesure du débit — Canaux jaugeurs à col rectangulaire,  
à col trapézoïdal et à col en U*



Reference number  
ISO 4359:2013(E)

© ISO 2013



**COPYRIGHT PROTECTED DOCUMENT**

© ISO 2013

All rights reserved. Unless otherwise specified, no part of this publication may be reproduced or utilized otherwise in any form or by any means, electronic or mechanical, including photocopying, or posting on the internet or an intranet, without prior written permission. Permission can be requested from either ISO at the address below or ISO's member body in the country of the requester.

ISO copyright office  
Case postale 56 • CH-1211 Geneva 20  
Tel. + 41 22 749 01 11  
Fax + 41 22 749 09 47  
E-mail [copyright@iso.org](mailto:copyright@iso.org)  
Web [www.iso.org](http://www.iso.org)

Published in Switzerland

# Contents

Page

<b>Foreword</b> .....	<b>v</b>
<b>1 Scope</b> .....	<b>1</b>
<b>2 Normative references</b> .....	<b>1</b>
<b>3 Terms and definitions</b> .....	<b>1</b>
<b>4 Symbols</b> .....	<b>2</b>
<b>5 Flume types and principles of operation</b> .....	<b>3</b>
<b>6 Installation</b> .....	<b>6</b>
6.1 Selection of site.....	6
6.2 Installation conditions.....	8
<b>7 Maintenance</b> .....	<b>10</b>
<b>8 Measurement of head</b> .....	<b>11</b>
8.1 General.....	11
8.2 Location of head measurement(s).....	11
8.3 Gauge wells.....	11
8.4 Zero setting.....	12
<b>9 General equations for discharge</b> .....	<b>12</b>
9.1 Discharge based on critical flow in the flume throat.....	12
9.2 Discharge based on observed upstream head.....	13
9.3 Calculation of stage-discharge relationships.....	27
9.4 Approach velocity and coefficient of velocity.....	27
9.5 Selection of flume size and shape.....	28
<b>10 Rectangular-throated flume</b> .....	<b>30</b>
10.1 Description.....	30
10.2 Location of head measurement section.....	30
10.3 Provision for modular flow.....	30
10.4 Evaluation of discharge for a given observed upstream head.....	31
10.5 Computation of stage-discharge relationship.....	35
10.6 Limits of application.....	35
<b>11 Trapezoidal-throated flumes</b> .....	<b>36</b>
11.1 Description.....	36
11.2 Location of head measurement section.....	36
11.3 Provision for modular flow.....	37
11.4 Evaluation of discharge — Coefficient method.....	37
11.5 Computation of stage-discharge relationship.....	40
11.6 Limits of application.....	42
<b>12 U-throated (round-bottomed) flumes</b> .....	<b>43</b>
12.1 Description.....	43
12.2 Location of head measurement section.....	44
12.3 Provision for modular flow.....	44
12.4 Evaluation of discharge — Coefficient method.....	44
12.5 Computation of stage-discharge relationship.....	48
12.6 Limits of application.....	50
<b>13 Uncertainties of flow measurement</b> .....	<b>51</b>
13.1 General.....	51
13.2 Combining measurement uncertainties.....	52
13.3 Percentage uncertainty of discharge coefficient $u^*(C)$ for critical-depth flumes.....	54
13.4 Uncertainty budget.....	54
<b>14 Example of uncertainty calculations</b> .....	<b>55</b>
14.1 General.....	55

14.2	Characteristics — Gauging structure.....	55
14.3	Characteristics — Discharge calculation.....	55
14.4	Characteristics — Discharge coefficient.....	55
14.5	Characteristics — Gauged head instrumentation.....	56
14.6	Characteristics — Throat width.....	56
14.7	Overall uncertainty in discharge.....	57
<b>Annex A (informative) Simplified head-discharge relationships for flume.....</b>		<b>58</b>
<b>Annex B (informative) Introduction to measurement uncertainty.....</b>		<b>63</b>
<b>Annex C (informative) Sample measurement performance for use in hydrometric worked examples.....</b>		<b>72</b>
<b>Annex D (informative) Spreadsheets for use with this International Standard.....</b>		<b>75</b>
<b>Bibliography.....</b>		<b>77</b>

## Foreword

ISO (the International Organization for Standardization) is a worldwide federation of national standards bodies (ISO member bodies). The work of preparing International Standards is normally carried out through ISO technical committees. Each member body interested in a subject for which a technical committee has been established has the right to be represented on that committee. International organizations, governmental and non-governmental, in liaison with ISO, also take part in the work. ISO collaborates closely with the International Electrotechnical Commission (IEC) on all matters of electrotechnical standardization.

International Standards are drafted in accordance with the rules given in the ISO/IEC Directives, Part 2.

The main task of technical committees is to prepare International Standards. Draft International Standards adopted by the technical committees are circulated to the member bodies for voting. Publication as an International Standard requires approval by at least 75 % of the member bodies casting a vote.

Attention is drawn to the possibility that some of the elements of this document may be the subject of patent rights. ISO shall not be held responsible for identifying any or all such patent rights.

ISO 4359 was prepared by Technical Committee ISO/TC 113, *Hydrometry*, Subcommittee SC 2, *Flow measurement structures*.

This second edition cancels and replaces the first edition (ISO 4359:1983), which has been technically revised. It also incorporates the Technical Corrigendum ISO 4359:1983/Corr.1:1999.





# Flow measurement structures — Rectangular, trapezoidal and U-shaped flumes

## 1 Scope

This International Standard specifies methods for the measurement of flow in rivers and artificial channels under steady or slowly varying flow conditions, using certain types of standing-wave, or critical-depth, flumes.

A wide variety of flumes has been developed, but only those which have received general acceptance after adequate research and field testing, and which therefore do not require *in situ* calibration, are considered.

The flow conditions considered are uniquely dependent on the upstream head, i.e. subcritical flow must exist upstream of the flume, after which the flow accelerates through the contraction and passes through its critical depth (see [Figure 1](#)). The water level downstream of the structure is low enough to have no influence upon its performance.

This International Standard is applicable to three commonly used types of flumes, covering a wide range of applications, namely rectangular-throated, trapezoidal-throated and U-throated. Typical field installations are shown in [Figure 2](#). Site conditions are important and [Figure 3](#) shows acceptable velocity profiles in the approach channel.

Detailed illustrations of the three types of flumes covered by this International Standard are given as follows:

- a) rectangular-throated (see [Figure 4](#));
- b) trapezoidal-throated (see [Figure 5](#));
- c) U-throated, i.e. round-bottomed (see [Figure 6](#)).

It is not applicable to a form of flume referred to in the literature — sometimes called a “Venturi” flume — in which the flow remains subcritical throughout.

**NOTE** This form is based on the same principle as a Venturi meter used within a closed conduit system and relies upon gauging the head at two locations and the application of Bernoulli’s energy equation.

## 2 Normative references

The following documents, in whole or in part, are normatively referenced in this document and are indispensable for its application. For dated references, only the edition cited applies. For undated references, the latest edition of the referenced document (including any amendments) applies.

ISO 772, *Hydrometry — Vocabulary and symbols*

## 3 Terms and definitions

For the purposes of this document, the terms and definitions given in ISO 772 apply.

## 4 Symbols

Units of measurement are metres (m) and seconds (s) or derivatives of these.

Symbol	Quantity	Unit of measurement
$A$	area of cross-section of flow	m <sup>2</sup>
$B$	width of approach channel (width at bed if trapezoidal)	m
$b$	width of flume throat (width at bed if trapezoidal)	m
$C$	overall coefficient of discharge (rectangular flumes)	non-dimensional
$C_c$	coefficient of contraction	non-dimensional
$C_D$	coefficient of discharge	non-dimensional
$C_s$	shape coefficient for trapezoidal throated and U-throated flumes	non-dimensional
$C_v$	coefficient allowing for the effect of approach velocity	non-dimensional
$D$	diameter of base of U-throated flume	m
$d$	depth of flow	m
$E$	specific energy (relative to local invert)	m
$Fr$	Froude number	non-dimensional
$g$	gravitational acceleration	m/s <sup>2</sup>
$H$	total head (relative to a specified datum, such as a flume invert)	m
$H^*$	correction to the total head	m
$h$	gauged head	m
$k_s$	equivalent sand roughness of surface, after Nikuradse	mm
$L$	length of prismatic section of the contraction at a flume	m
$L_1$	length of bellmouth entrance	m
$L_2$	length of slope (if present) between throat and downstream stilling basin or channel floor	m
$L_3$	length of stilling basin (if present)	m
$m$	side-slope (m horizontal to 1 vertical)	non-dimensional
$n$	number of measurements in series	non-dimensional
$P$	wetted perimeter of flow cross-section	m
$p$	height of flume invert above the invert of the approach channel	m
$Q$	discharge	m <sup>3</sup> /s
$R$	radius	m
$Re$	Reynolds number	non-dimensional
$r_p$	radius of hump	m
$R_1$	radius of bellmouth entrance	m
$S$	standard deviation	—
$\bar{S}$	standard error of the mean	—
$\bar{v}$	average velocity through a cross-section, defined by $Q/A$	m/s
$w$	water surface width	m

Symbol	Quantity	Unit of measurement
$u^*(Q)_{68}$	overall percentage uncertainty in the determination of discharge expressed as a percentage standard deviation at 68 % confidence limits	non-dimensional
$u^*(b)$	percentage uncertainty in $b$ (or $D$ )	non-dimensional
$u^*(C)$	percentage uncertainty in the combined coefficient value	non-dimensional
$u^*(h)$	percentage uncertainty in $h$	non-dimensional
$u^*(m)$	percentage uncertainty in $m$	non-dimensional
$\alpha$	kinetic energy correction coefficient (taking into account non-uniformity of velocity distribution)	non-dimensional
$\beta$	coefficient dependent on mean curvature of stream lines	non-dimensional
$\gamma, \varphi, \psi$	coefficients in the uncertainty computation	—
$\delta^*$	boundary layer displacement thickness	m
$\eta$	a numerical coefficient related to the sideslope angle in trapezoidal flumes	non-dimensional
$\nu$	kinematic viscosity of the fluid	m <sup>2</sup> /s
$\theta$	semi-angle subtended at the centre of curvature of the invert of a U-throated flume between the water surface and the vertical	non-dimensional
$\sigma$	semi-angle subtended at the centre of curvature of the invert of a U-throated flume between the water surface and the horizontal	non-dimensional
<b>Subscripts</b>		
a	values in approach channel	
c	values at critical flow	
d	values downstream of the flume	
e	effective values after making allowance for boundary layer effects	
1	values assuming an ideal frictionless fluid	
M	maximum value	

## 5 Flume types and principles of operation

**5.1** The flumes covered by this International Standard are often known as “long-throated” or “critical-depth” flumes and rely fundamentally on the occurrence of critical flow in the flume throat. When this occurs, there is a unique relationship, for a given flume geometry, between the upstream head and the discharge, that is independent of the conditions downstream of the flume throat. [Figure 1](#) shows a simplified sketch of where the critical depth typically occurs in a critical depth flume and the consequent water surface profile through a long-throated trapezoidal flume, together with key hydraulic and geometrical parameters.

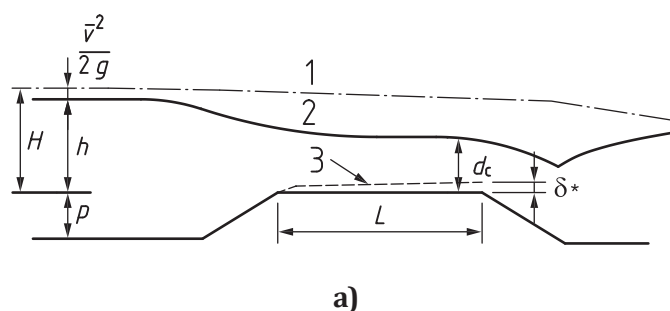

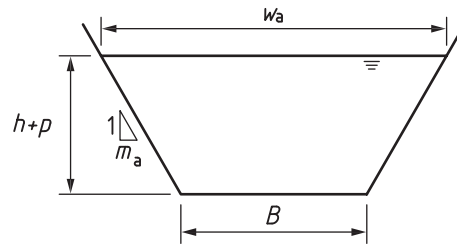

**b) Section in approach channel upstream from throat**

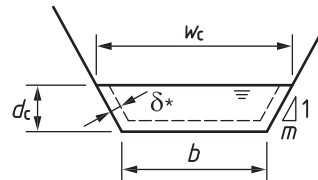

**c) Section at downstream end of throat**

**Key**

- 1 total energy line
  - 2 typical flow profile
  - 3 edge of boundary layer displacement thickness
- $\delta^*$  has been exaggerated.

**Figure 1 — Trapezoidal-throated flume showing key geometrical parameters, water surface profile and development of boundary layer displacement thickness (after Figure 8.1, Ref.[9])**

**5.2** Because the flume design is based on critical flow, this International Standard is largely based on fundamental hydraulic theory, without the need for the large-scale volumetric testing that has been used to derive the coefficients for other forms of flow measurement structure. In order to obtain critical flow within the throat of the flume, the following conditions shall be satisfied.

- a) The throat of the flume shall be long enough for the flow to be virtually parallel with the flume invert, so that hydrostatic pressure conditions occur at the *control section*.
- b) The entrance to the flume throat shall be shaped so that there are virtually no energy losses between the point where the head is gauged and the point where critical flow occurs.
- c) The flume throat shall constrict the channel severely enough to raise the energy level in the throat sufficiently high above the energy level downstream to ensure that the flume is “modular”.

**5.3** [Figure 2](#) shows examples of flow in rectangular-throated, trapezoidal-throated and U-throated flumes. The choice of flume type from these three depends upon several factors, such as the range of discharge to be measured, the accuracy required, the head available and whether or not the flow carries sediment that is liable to accrete. The graphs in [Annex A](#) give the user of this International Standard a means of quickly comparing the idealized performance of a range of flume designs, to aid a preliminary choice of the size and form of flume needed to deliver the required discharge capacity and stage–discharge relationship.



a) Rectangular-throated flume b) Trapezoidal-throated flume c) U-throated flume

**Figure 2 — Examples of rectangular-throated, trapezoidal-throated and U-throated flumes**

**5.4** The rectangular-throated flume is the simplest to construct. It generally proves necessary to raise the invert of the flume throat above the bed of the channel upstream, in order to generate a constriction that is sufficiently severe to allow low flows to be gauged. However, this may result in a regime of cyclic sediment accretion and erosion upstream, which would affect the accuracy and consistency of gauging.

**5.5** The trapezoidal-throated flume is more appropriate where a wide range of discharge is to be measured with consistent accuracy. This shape of throat is also more likely to be suitable where it is desirable to produce a particular stage-discharge relationship. In some cases, it is not necessary to raise the invert of the throat above the approach channel invert when using a trapezoidal-throated flume, so reducing the risk of upstream sediment accretion.

**5.6** The U-throated flume is useful for installation in a U-shaped channel or where the flow is from a circular-section conduit. It has found particular application in sewers and at sewage works.

**5.7** The detailed theory for the critical-depth flume is given in [Clauses 9 to 12](#), but is introduced here in simplified form, based on the assumption of a uniform velocity across the flow section and disregarding boundary layer effects. The basic discharge equation for a critical-depth flume can be derived from the general energy equation:

$$H = d + \frac{\bar{v}^2}{2g} = d + \frac{Q^2}{2gA^2} \quad (1)$$

where

$H$  is the total head above the flume invert;

$d$  is the depth of flow;

$\bar{v}$  is the average velocity through the section ( $= Q/A$ );

$Q$  is the discharge;

$A$  is the area of the flow cross-section;

$g$  is the gravitational acceleration.

By differentiating the energy Formula (1) with respect to depth, it can be shown that, for critical flow:

$$Q = \sqrt{\frac{gA_c^3}{w_c}} \quad (2)$$

where subscript c refers to conditions at the critical-flow section.

Substituting Formula (2) into Formula (1) and disregarding any energy losses between the gauging section and the critical-flow section, the following is obtained:

$$H = d_c + \frac{A_c}{2w_c} \quad (3)$$

**5.8** In general, Formulae (2) and (3) are solved alongside each other for successive values of depth  $d_c$  (with the corresponding values of area and surface width) to obtain the relationship between  $H$  and  $Q$ , but for the special case of a flume with a rectangular throat (see [Figure 4](#)), they can be combined to produce the explicit relationship:

$$Q = \frac{2}{3} \sqrt{\frac{2g}{3}} b H^{1.5} \quad (4)$$

**5.9** This is readily recognizable as the same equation that applies (for an ideal fluid) for the flow over a round-nosed horizontal-crested weir. In order to extend the use of this equation, three additional coefficients may be introduced, resulting in the following generalized equation for long-throated critical-depth flumes:

$$Q = \frac{2}{3} \sqrt{\frac{2g}{3}} C_D C_s C_v b h^{1.5} \quad (5)$$

where the coefficients are as follows:

$C_D$  is a discharge coefficient that takes account of the non-ideal fluid properties, in particular the effect of the boundary layer in the throat;

$C_s$  is a shape coefficient, to allow for the effect of a non-rectangular flow section in the throat;

$C_v$  is a velocity coefficient, to allow the upstream gauged head,  $h$ , to be used in place of the total head or specific energy,  $H$ .

**5.10** Equations for these coefficients are given in [Clauses 9](#) to [12](#) and generally require an iterative approach to be adopted.

## 6 Installation

### 6.1 Selection of site

**6.1.1** The flume shall be located in a straight section of channel, avoiding local obstructions, roughness or unevenness of the bed.

**6.1.2** A preliminary study shall be made of the physical and hydraulic features of the proposed site, to check that it conforms (or can be constructed or modified so as to conform) to the requirements necessary for measurement of discharge by a flume. Particular attention should be paid to the following features in selecting the site.

- a) The availability of a straight length of approach channel of at least 10 times the maximum head anticipated.
- b) The existing velocity distribution.
- c) The avoidance of a steep channel, the characteristics of which would induce supercritical flow.
- d) The effects of any raised upstream water levels due to the measuring structure.
- e) Conditions downstream, including such influences as tides, confluences with other streams, sluice gates, mill dams and other controlling features which might cause submerged flow.
- f) The impermeability of the ground on which the structure is to be founded and the necessity for piling, grouting or other means of controlling seepage.
- g) The necessity for floodbanks, to confine the maximum discharge to the channel.
- h) The stability of the banks, and the necessity for trimming and/or revetment in natural channels.
- i) The clearance of rocks or boulders from the bed of the approach channel.
- j) Wind, which can have a considerable effect on the flow in a river, weir or flume, especially when these are wide and the head is small and when the prevailing wind is in a transverse direction (which would introduce a bias whose direction would depend on whether the gauge were at the windward or leeward side of the approach channel).

**6.1.3** If the site does not possess the characteristics necessary for satisfactory measurement, the site shall be rejected unless suitable improvements are practicable.

**6.1.4** If an inspection of the stream shows that the existing velocity distribution is reasonably uniform, then it may be assumed that the velocity distribution will remain satisfactory after the construction of the flume.

**6.1.5** If the existing velocity distribution is markedly non-uniform and no other site for the flume is feasible, due consideration shall be given to checking the distribution after installation of the flume and to improving it if necessary.

**6.1.6** Several methods are available for obtaining a more precise indication of irregular velocity distribution: velocity rods, floats or concentrations of dye can be used in small channels, the latter being useful in checking conditions at the bottom of the channel. A complete and quantitative assessment of velocity distribution may be made by means of a current-meter and other point velocity measurements.

NOTE Information about the use of current-meters is given in ISO 748. Further information on measuring river velocities and using acoustic Doppler profilers can be found in ISO/TS 24154.

The user should confirm that the dye material used is acceptable for flow measurement purposes within a natural channel in the country of operation.

**6.1.7** [Figure 3](#) gives typical examples of velocity distributions in channels of varying shape that can be taken as acceptable for flow measurement purposes.

**6.1.8** Flumes can act as obstacles to the movement of fish and other aquatic species. Care should therefore be taken to ensure that the installation of gauging structures such as flumes does not have a detrimental affect on the aquatic ecology where this might be an issue. In addition, the gauging structure may be subject to compliance with national or supranational legislation or regulations, such as the

European Parliament EU Water Framework Directive (Directive 2000/60/EC). Where the movement of aquatic life could be compromised by the installation of a flow measurement structure this should be reflected in the design. Alternatively, a fishpass in accordance with ISO 26906 should be installed.

**6.1.9** Reference to appropriate legislation should be made before a site for a measuring weir is chosen.

## **6.2 Installation conditions**

### **6.2.1 General requirements**

**6.2.1.1** The complete measuring installation consists of an approach channel, a measuring structure and a downstream channel. The conditions of each of these three components affect the overall accuracy of the measurements.

**6.2.1.2** Installation requirements include features such as the surface finish of the flume, the cross-sectional shape of channel, the channel roughness and the influence of control devices upstream or downstream of the gauging structure.

**6.2.1.3** The distribution and direction of velocity have an important influence on the performance of the flume, these factors being determined by the features mentioned above.

**6.2.1.4** Once a gauging flume has been installed, the user shall prevent any change that could affect the discharge characteristics.

### **6.2.2 Flume structure**

**6.2.2.1** The structure shall be rigid and watertight and capable of withstanding flood flow conditions without distortion or fracture, from outflanking or from downstream erosion. The axis shall be in line with the direction of flow of the upstream channel, and the geometry shall conform to the dimensions given in [Clauses 10, 11](#) and [12](#).

**6.2.2.2** The surfaces of the flume throat and the immediate approach channel shall be smooth. They shall be constructed in concrete with a smooth cement finish or surfaced with a smooth non-corrodible material. In laboratory installations, the finish shall be equivalent to rigid plastic, rolled sheet metal or planed, sanded and painted timber. The surface finish is of particular importance within the prismatic part of the throat but can be relaxed a distance along the profile  $0,5H_{\max}$  upstream and downstream of the throat proper.

The user should confirm that the building materials used in the construction of natural channels are acceptable in the country of operation.

**6.2.2.3** In order to minimize the uncertainty in the discharge, the following tolerances are acceptable:

- a) on the bottom width of the throat, 0,2 % of this width with an absolute maximum of 0,01 m;
- b) on deviation from a plane of the plane surfaces in the throat, 0,1 % of  $L$ ;
- c) on the width between vertical surfaces in the throat, 0,2 % of this width with a maximum of 0,01 m;
- d) on the average longitudinal and transverse slopes of the base of the throat, 0,1 %;
- e) on a slope of inclined surfaces in the throat, 0,1 %;
- f) on a length of the throat, 1 % of  $L$ ;
- g) on deviation from a cylindrical or a conical surface in the entrance transition to the throat, 0,1 % of  $L$ ;



- h) on deviation from a plane of the plane surfaces in the entrance transition to the throat, 0,1 % of  $L$ ;
- i) on deviation from a plan of the plane surface in the exit transition from the throat, 0,3 % of  $L$ ;
- j) on other vertical or inclined surfaces, deviation from a plane or curve, 1 %;
- k) on deviation from a plane of the bed of the lined approach channel, 0,1 % of  $L$ .

**6.2.2.4** The structure shall be measured on completion, and average values of relevant dimensions and their standard deviations at 68 % confidence limits computed. The former shall be used for computation of discharge and the latter shall be used to obtain the overall uncertainty in the determination of discharge.

### 6.2.3 Approach channel

**6.2.3.1** On all installations the flow in the approach channel shall be free from disturbance and shall have a velocity distribution as uniform as reasonably practicable over the cross-sectional area. [Figure 3](#) shows typical dimensionless velocity distributions in rectangular and trapezoidal channels, which are relevant in site selection. For a given shape of channel, the velocity distribution should be reasonably similar to one of those presented in [Figure 3](#). This can usually be verified by inspection or measurement. In the case of natural streams or rivers this can only be attained by having a long straight approach channel free from projections into the flow.

**6.2.3.2** The following are general recommendations and requirements related to the approach channel.

- a) Any alteration in the flow conditions owing to the construction of the flume should be considered. For example, there might be a build-up of shoals or debris upstream of the structure, which in time might affect the flow conditions. Any likely consequential changes in the water level therefore need to be taken into account in the design of gauging stations.
- b) In an artificial channel the cross-section shall be uniform and the channel shall be straight for a length equal to at least 10 times its water-surface width.
- c) In a natural stream or river the cross-section shall be reasonably uniform and the channel shall be straight for a sufficient length to ensure a reasonably uniform velocity distribution.
- d) If the entry to the approach channel is through a bend, or if the flow is discharged into the channel through a conduit or a channel of smaller cross-section, or at an angle, then a longer length of straight approach channel may be required to achieve a reasonably uniform velocity distribution.
- e) Vanes to straighten the flow shall not be installed closer to the points of measurement than a distance 10 times the maximum head to be measured.
- f) Under certain conditions, a standing wave may occur upstream of the gauging flume, for example if the approach channel is steep. Provided that this wave is at a distance of not less than 30 times the maximum head upstream, flow measurement is feasible, subject to confirmation that a reasonably uniform velocity distribution exists at the gauging station and that the Froude number in this section is no more than 0,6. Ideally, high Froude numbers should be avoided in the approach channel for accurate flow measurement. If a standing wave occurs within this distance the approach conditions and/or the flume shall be modified.

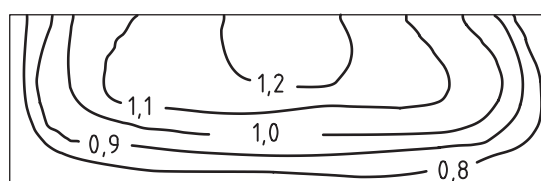

a)

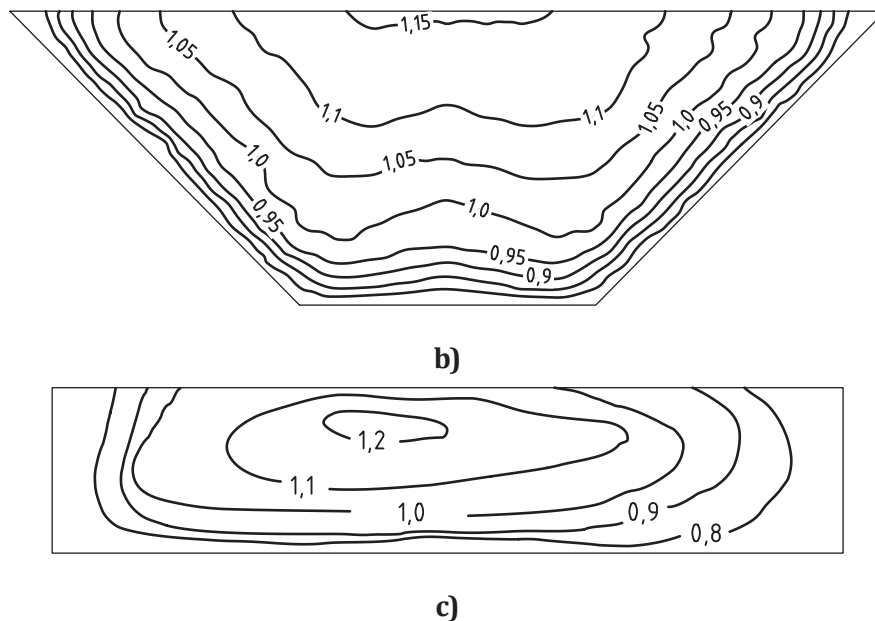

Figure 3 — Examples of typical dimensionless velocity distributions in approach channels

#### 6.2.4 Downstream conditions

**6.2.4.1** The channel downstream of the structure is usually of no importance as such if the flume has been so designed that the flow is modular under all operating conditions. A downstream gauge shall be provided to measure tailwater levels to determine if and when drowned flow occurs.

**6.2.4.2** If downstream scouring (which could lead to instability of the structure) is anticipated, then particular measures to prevent this may be necessary.

### 7 Maintenance

**7.1** Maintenance of the measuring structure and the approach channel is important, in order to secure accurate continuous measurements.

**7.2** The approach channel shall be kept free of silt, vegetation and obstructions that might have deleterious effects on flow conditions specified for the standard installation. The float well and the entry from the approach channel shall also be kept clean and free from deposits. The downstream channel shall be kept free of obstructions that might cause the weir to drown.

**7.3** The flume structure shall be kept clean and free from clinging debris, particularly within the throat section, and care shall be taken in the process of cleaning to avoid damage to the structure.

**7.4** Head-measurement devices, connecting conduits and stilling wells shall be cleaned and checked for leakage. The hook or point gauge, float or other instrument used to measure head shall be checked periodically to ensure accuracy.

## 8 Measurement of head

### 8.1 General

**8.1.1** Where spot measurements are required, the heads can be measured by vertical gauges, hooks, points, wires or tape gauges. Where continuous records are required, recording gauges shall be used, typically based on float and shaft encoders, ultrasonics or pressure transducers.

**8.1.2** As the size of the flume and head reduces, small discrepancies in construction and in the zero setting and reading of the head measuring device become of greater relative importance.

### 8.2 Location of head measurement(s)

**8.2.1** Stations for the measurement of head on the flume shall be located at a sufficient distance upstream from the flume to avoid the region of surface drawdown. On the other hand, they shall be close enough to the flume to ensure that the energy loss between the section of measurement and the control section within the flume throat shall be negligible. The location for head measurement is dealt with in [Clauses 10, 11](#) and [12](#).

**8.2.2** Flow is modular when it is independent of variations in tailwater level. This condition is met when the tailwater total head above flume invert level is less than or equal to the submergence ratio at the modular limit, as defined in [Clauses 10, 11](#) and [12](#) for rectangular, trapezoidal and U-throated flumes.

**8.2.3** A significant error in the calculated discharge will develop if the tailwater level causes the submergence ratio to exceed the modular limit. A downstream gauge shall be installed to check that the modular limit is not exceeded. A simple staff gauge in the downstream channel will normally be the minimum requirement for this purpose.

### 8.3 Gauge wells

**8.3.1** It is common to measure the upstream head in a gauge well to reduce the effects of water surface oscillations. Alternatively, data-logged results can be post-processed to eliminate or reduce such oscillations.

**8.3.2** Periodic checks on the measurement of the head in the approach channel shall be made.

**8.3.3** Gauge wells shall be vertical and of sufficient height and depth to cover the full range of water levels. In field installations they shall have a minimum height of 0,3 m above the highest water levels expected. Gauge wells shall be connected to the appropriate head measurement positions by means of suitable conduits.

**8.3.4** Both the well and the connecting pipe shall be watertight. Where the well is provided for the accommodation of the float of a level recorder, it shall be of adequate size and depth.

**8.3.5** The pipe shall have its invert not less than 0,06 m below the lowest level to be gauged.

**8.3.6** Pipe connections to the measurement position shall terminate either flush with, or at right angles to, the boundary of the approach channel. The channel boundary shall be plain and smooth (equivalent to carefully finished concrete) within a distance 10 times the diameter of the pipes from the centreline of the connection. The pipes may be oblique to the wall only if they are fitted with a removable cap or plate, set flush with the wall, through which a number of holes are drilled. The edges of these holes shall not be rounded or burred. Perforated cover plates are not recommended where weed or silt are likely to be present.

## 8.4 Zero setting

**8.4.1** Accurate initial setting of the zero of the head measuring device with reference to the level of the flume invert and subsequent regular checking of the settings are essential.

**8.4.2** An accurate means of checking the zero at frequent intervals shall be provided. Benchmarks, in the form of horizontal metal plates, shall be set up on the top of the vertical sidewalls and in the gauge wells. These shall be accurately levelled to ensure their elevation relative to the flume invert level is known.

**8.4.3** Instrument zeros can be checked relative to these benchmarks without the necessity of resurveying the crest each time. Any settlement of the structure may, however, affect the relationships between the flume invert and benchmark levels and it is advisable to make occasional checks on these relationships.

**8.4.4** For small installations, a zero check based on the water level (either when the flow ceases or just begins) is susceptible to serious errors due to surface tension effects and shall not be relied upon.

## 9 General equations for discharge

### 9.1 Discharge based on critical flow in the flume throat

**9.1.1** Critical depth theory, augmented by experimental data, may be used to deduce the basic equations for free discharge through streamlined contractions. Since the simple theory relates to the frictionless flow of an ideal fluid, an additional coefficient, known as the *coefficient of discharge*,  $C_D$ , has to be introduced to deal with the flow of a real fluid, such as water, and to take into account the development of boundary layers that occur within the throat. The value of the coefficient  $C_D$  is usually either based on experimental studies or deduced by considering a modification to the simple theory. Another coefficient, known as the *shape coefficient*,  $C_s$ , is then required to generalize the simple theory to make it applicable to flow through any cross-sectional shape, rather than just flow through a rectangular flume. Finally, a third coefficient, known as the *velocity of approach coefficient*,  $C_v$ , is then used to relate the head in the throat with the gauged head, typically measured a short distance upstream of the throat in the approach channel.

**9.1.2** The specific energy,  $E$ , of flow in an open channel is given by:

$$E = \beta d + \frac{\alpha \bar{v}^2}{2g} \quad (6)$$

where

$d$  is the depth of flow;

$\bar{v}$  is the average velocity through the section;

$\alpha$  is the kinetic energy correction coefficient, which takes into account the non-uniformity in velocity distribution;

$\beta$  is a coefficient which depends on the mean curvature of the streamlines.

**9.1.3** The equation of continuity is

$$Q = A\bar{v} \quad (7)$$

where

$Q$  is the discharge;

$A$  is the area of the flow cross-section.

Hence:

$$E = \beta d + \frac{\alpha Q^2}{2gA^2} \quad (8)$$

**9.1.4** Critical flow occurs when  $E$  has a minimum value for a given discharge  $Q$ , treating depth  $d$  and area  $A$ , which is related to  $d$  for any given cross-sectional geometry, as the variables. It can be shown that the specific energy is a minimum when

$$Q^2 = \frac{\beta g A^3}{\alpha w} \quad (9)$$

where  $w$  is the water surface width.

**9.1.5** Experimentally observed velocity profiles indicate that the velocity distribution is almost uniform in the throat of a flume, and it may be assumed therefore that  $\alpha = 1$  under certain conditions. If the streamlines are not significantly curved, a condition approached if the throat is in excess of a certain minimum length, then  $\beta = 1$ . Hence the basic equation defining critical flow through a streamlined contraction is:

$$Q = \sqrt{\frac{g A_c^3}{w_c}} \quad (10)$$

where the subscript  $c$  indicates critical flow, assumed to occur within the throat of a flume,  $A_c$  is the area of cross-section and  $w_c$  is the surface width of the cross-section. This is the same equation as Formula (2), in [Clause 5](#).

**9.1.6** Formula (10) is not immediately applicable to the theoretical derivation of a stage–discharge relationship, because

- a) it does not take account of the development of boundary layers that result in slower moving fluid along the bed and sidewalls of the throat, and
- b) it is based on the area and water surface width at the critical section, the location of which is ill-defined, so that direct measurement of the water level at that section is impractical.

Thus the basic equation has to be transformed into a more practical form, and adjusted to take account of the boundary effects.

## 9.2 Discharge based on observed upstream head

**9.2.1** For the flow of a real fluid through a streamlined contraction, Formula (10) may be developed further to give the discharge in terms of the head measured a short distance upstream and for each type of approach channel cross-sectional shape and throat shape. See [Figures 4 to 6](#) for the three standard shapes of flume often used in practice: rectangular, trapezoidal and U-throated. Reference should also be made to [Figure 1](#), which shows the general features of flow through a trapezoidal-throated flume, indicating a

typical water surface profile, energy line and how the boundary layer displacement thicknesses reduce the cross-sectional area of the throat. The theory is now developed further, initially for flow through a rectangular flume and then generalized for flow in other types of flume.

9.2.2 For flow in a rectangular flume (see [Figure 4](#)) the total head under critical flow conditions,  $H_c$ , may be linked to the critical depth,  $d_c$ , using Formula (10), as follows:

$$H_c = d_c + \frac{Q^2}{2gA_c^2} = d_c + \frac{A_c}{2w_c} = d_c + \frac{bd_c}{2b} = \frac{3}{2}d_c \quad (11)$$

Applying Formula (10) to a rectangular section:

$$Q^2 b = g (bd_c)^3 \quad (12)$$

The discharge through a streamlined rectangular contraction may then be expressed in terms of the total head at the throat,  $H_c$ , by linking Formulae (11) and (12) to give

$$Q = \left(\frac{2}{3}\right)^{3/2} g^{1/2} b H_c^{3/2} \quad (13)$$

This is the same as Formula (4) in [Clause 5](#), but expressed differently.

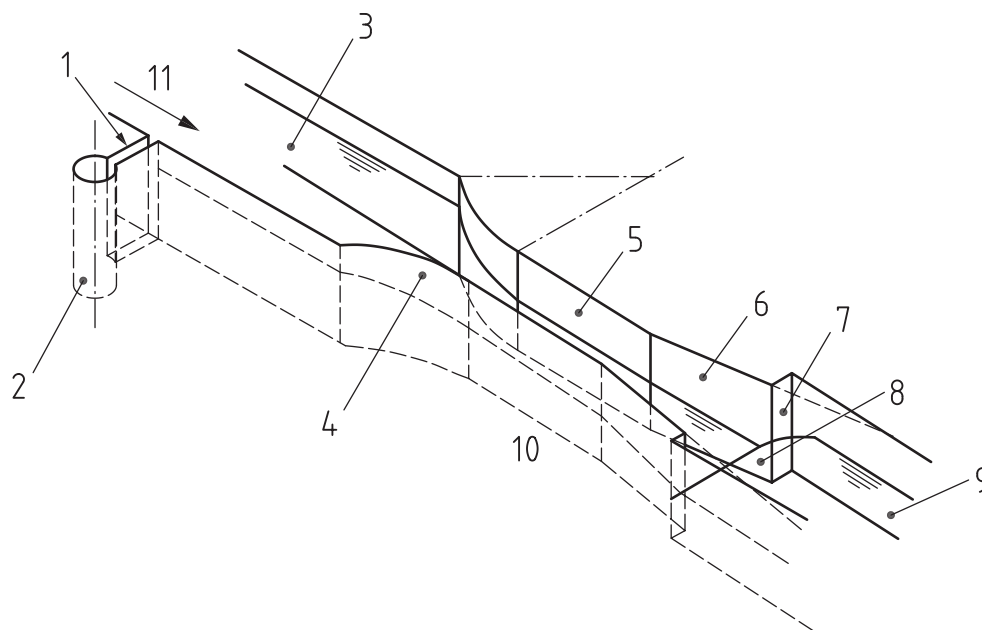

a) Isometric of level-invert rectangular-throated flume ( $p = 0$ )

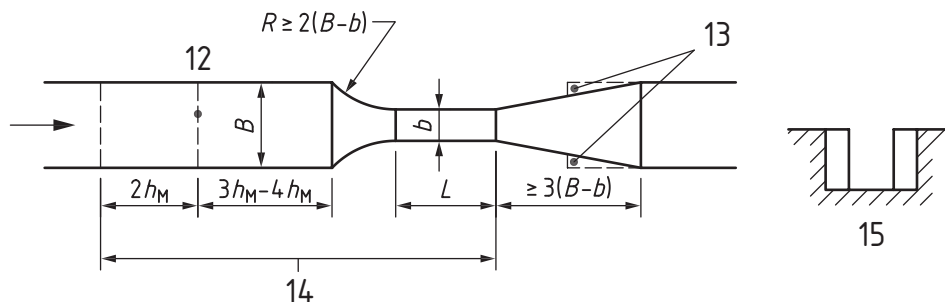

b) Plan view of rectangular-throated flume

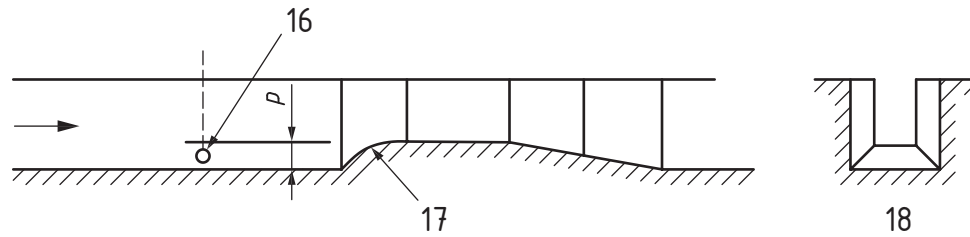

**c) Longitudinal section of rectangular-throated flume with raised invert (hump)**

**Key**

1	connecting slot or pipe	10	horizontal invert
2	stilling well	11	flow
3	approach channel	12	head gauging section
4	entrance transition	13	when recovery of head is not important, the exit transition may be truncated after half its length
5	throat	14	in a flume without a hump ( $p = 0$ ) the invert over this length shall be truly level
6	exit transition	15	front view (level invert)
7	example of truncation	16	connection to stilling well
8	standing wave	17	radius that shall be chosen so that the bottom contraction starts at the same section as the side contractions (for a flume with a bottom contraction only, the radius = $4p$ )
9	exit channel	18	front view (raised invert)

**Figure 4 — Rectangular-throated flume in rectangular channel**

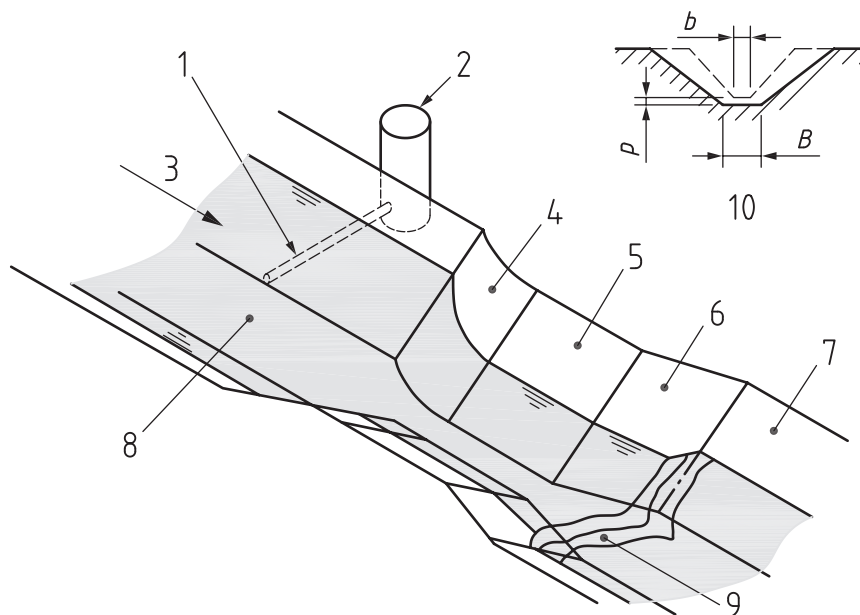

a) Isometric view of level invert flume ( $p = 0$ )

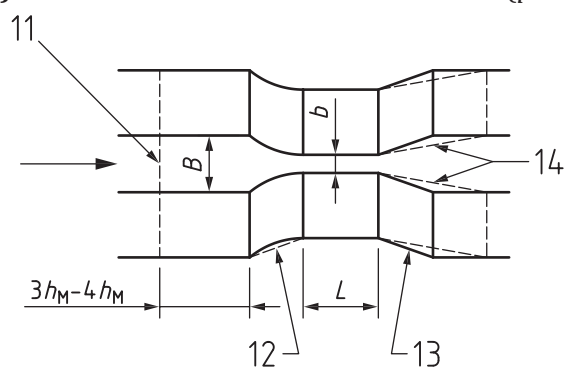

b) Plan view (example shown, no hump  $m_a = m$ , skew cylinder entrance transition)

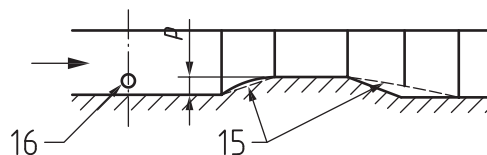

c) Longitudinal section of flume with raised invert (hump)

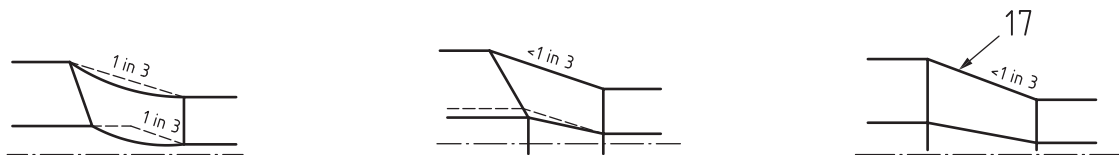

Conical ( $m_a \neq m$ , no hump)

Plane ( $m_a \neq m$ , no hump)

Warped ( $m_a \neq m$ , no hump)

d) Examples of plans of entrance transitions



**Key**

- |   |                     |    |  |
|---|---------------------|----|--|
| 1 | connecting pipe     | 10 | front view with hump ( $p \neq 0$ )  |
| 2 | stilling well       | 11 | head gauging section   |
| 3 | flow                | 12 | radius chosen so that entrance transition lies entirely within plane defining 1 in 3 contraction |
| 4 | entrance transition | 13 | not more than 1 in 3 expansion on any horizontal section (or equivalent curve)                   |
| 5 | throat              | 14 | 1 in 6 expansion for high modular limit and head recovery  |
| 6 | exit transition     | 15 | not more than 1 in 3 (or equivalent curve)   |
| 7 | exit channel        | 16 | connection to stilling well  |
| 8 | approach channel    | 17 | generators are straight lines  |
| 9 | standing wave       |    |  |

**Figure 5 — Trapezoidal-throated flume in trapezoidal channel**

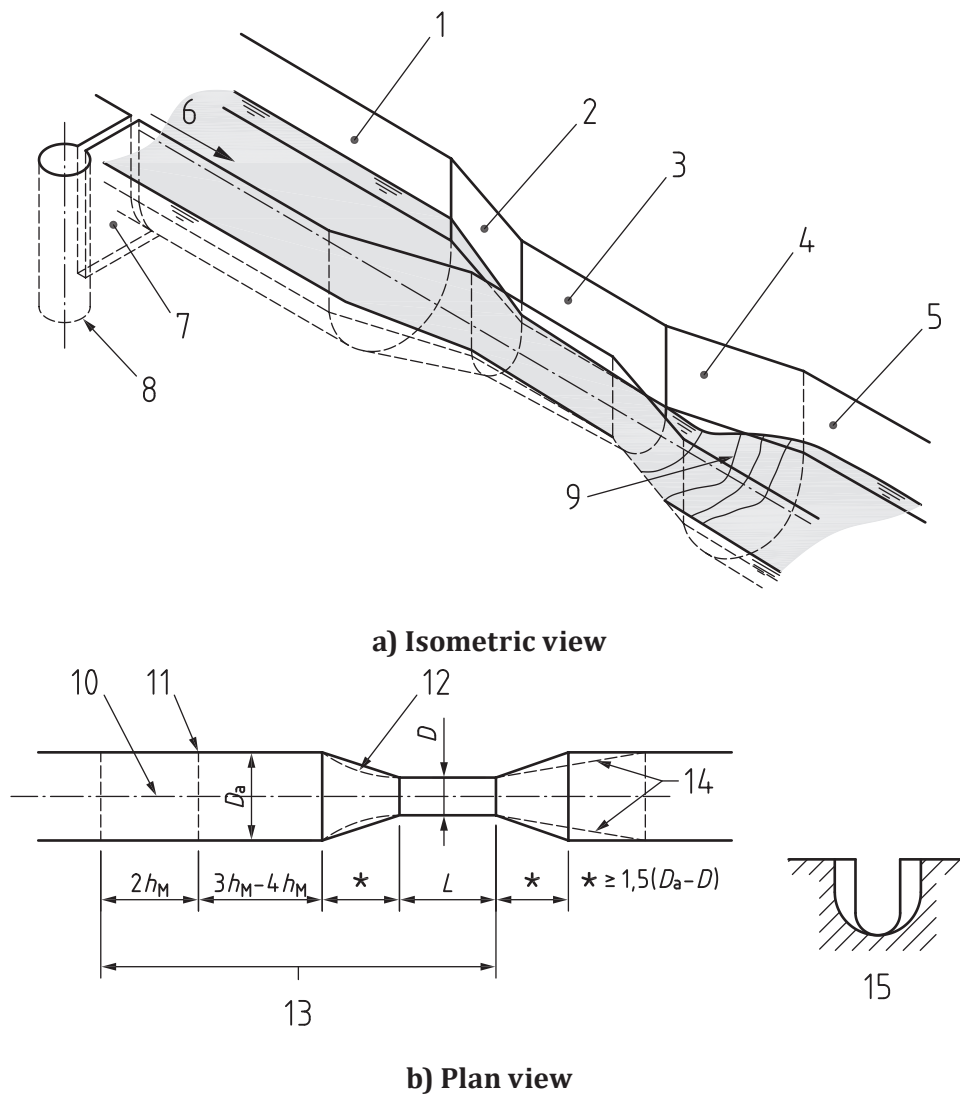

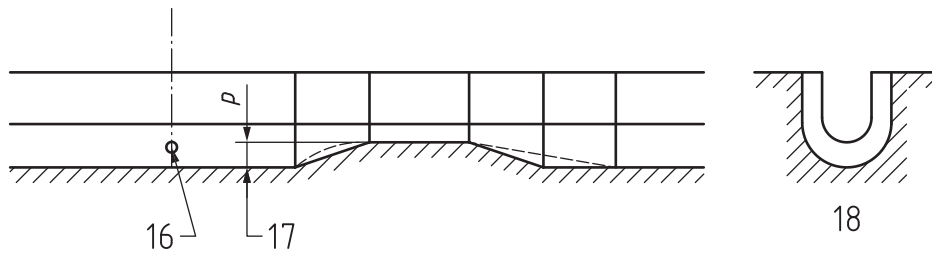

**c) Longitudinal section of flume with raised invert (hump)**

**Key**

1	approach channel	10	invert line
2	entrance transition	11	head gauging section
3	throat	12	the straight-sided contraction may be replaced by curved surfaces, provided they lie within the full lines
4	exit transition	13	in a flume without a hump ( $p = 0$ ), the invert over this length shall be truly level
5	exit channel	14	1 in 6 expansion for high modular limit and head recovery
6	flow	15	front view (level invert)
7	connecting slot or pipe	16	connection to stilling well
8	stilling well	17	in a level flume, $p = 0$ ; for a flume with a hump, a convenient value of $p$ is 0,5 ( $D_a - D$ )
9	standing wave	18	front view (raised invert)

**Figure 6 — U-throated flume in U-shaped channel**

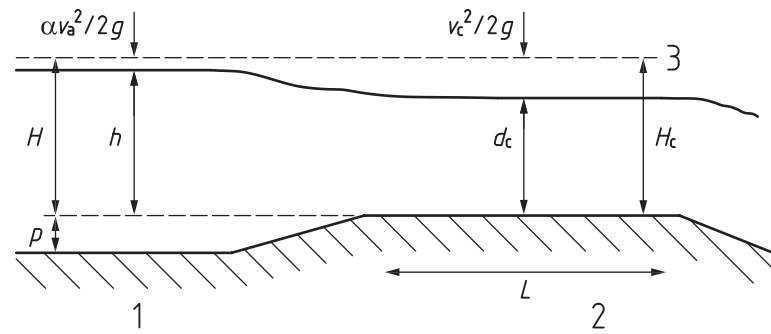

a) Frictionless flow with an ideal fluid

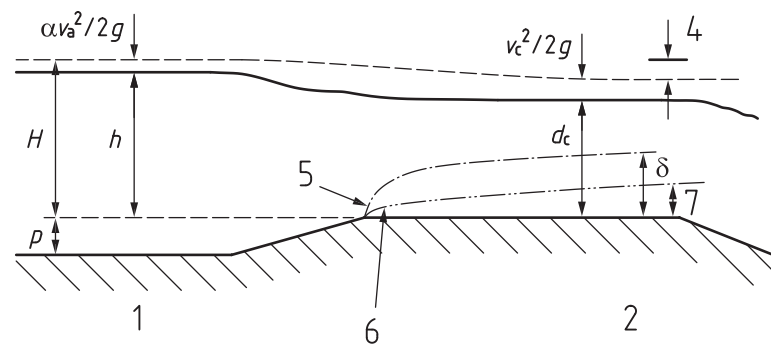

b) Real fluid flow

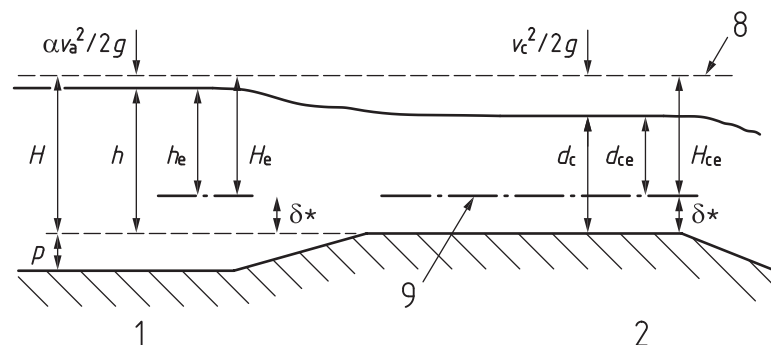

c) Equivalent ideal fluid with raised crest position

**Key**

- |                                |  |
|--------------------------------|--|
| 1 gauging section              | 6 boundary layer displacement thickness, $\delta^*$  |
| 2 throat                       | 7 $\delta^*$ at end of throat                        |
| 3 assumption of no energy loss | 8 assumption of same energy level as in a)           |
| 4 energy loss                  | 9 equivalent crest position moved $\delta^*$ upwards |
| 5 boundary layer, $\delta$     |  |

**Figure 7 — Notation for flow at throat and at upstream gauging section**

**9.2.3** In order to account for the presence of boundary layers that form in the throat section, growing progressively from the leading edge, the boundary layer displacement thickness is used to modify the geometrical parameters of the cross-section of the throat as follows:

$$Q = \left(\frac{2}{3}\right)^{3/2} g^{1/2} b_e H_{ce}^{3/2} \quad (14)$$

where

$b_e$  is the effective width of flume throat (e.g. for a rectangular cross-section,  $b_e = b - 2\delta_*$ );

$H_{ce}$  is the effective total head at the throat (i.e.  $H_{ce} = H_c - \delta_*$ ), which also equals the total head upstream,  $H_e$ ;

$\delta_*$  is the boundary layer displacement thickness.

**9.2.4** The boundary layer displacement thickness is the amount by which a boundary surface needs to be moved normal to that surface to compensate for the reduced velocity caused by the boundary layer. It also effectively implies that the fluid may be treated as if it were an ideal fluid throughout the rest of the flow domain. Typically, a boundary layer develops from any leading edge of a surface, grows slowly, and the corresponding value of  $\delta_*$  is a small proportion of the actual thickness,  $\delta$ . Figure 7 indicates how these concepts are applied to long-throated flumes. Figure 7 c) shows how the actual and effective heads are related, both at the throat and at the upstream gauging section. Figure 8 shows effective cross-sections of various flumes, showing the effect of the boundary layer displacement thicknesses on the throat geometry.

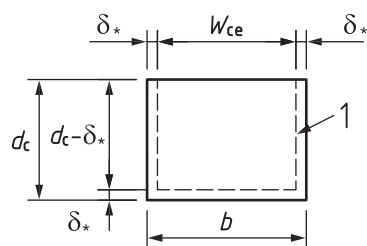

a) Rectangular throat

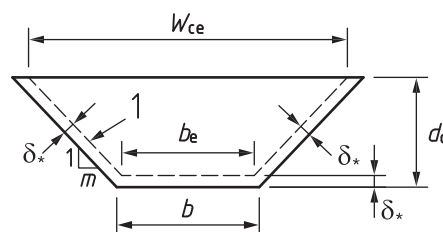

b) Trapezoidal throat

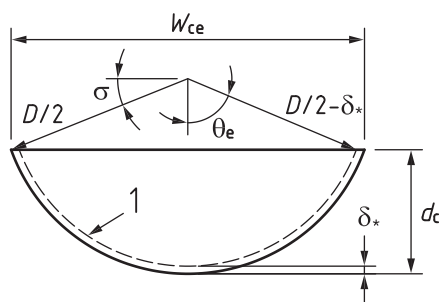

c) U-shaped throat with water below axis

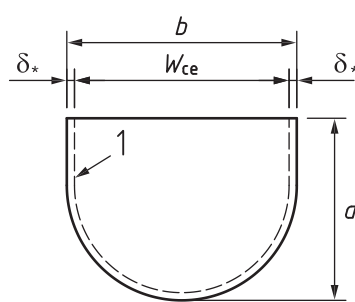

d) U-shaped throat with water above axis

**Key**

1 edge of boundary layer displacement thickness

**Figure 8 — Effective cross-sections of various flumes showing the effect of boundary layer displacement thicknesses**

**9.2.5** Because of the practical difficulties in simply measuring the depth of flow in the throat,  $d_c$ , and using it to determine the discharge via Formula (12), it is customary to measure the head upstream of the throat,  $h$ , in the approach channel, as also shown in Figures 1, 4 and 7. Formula (14) can then be expressed in terms of  $h_e$ , the effective head gauged upstream of the structure, for flumes with rectangular throats, as follows:

$$Q = \left(\frac{2}{3}\right)^{3/2} g^{1/2} C_v b_e h_e^{3/2} \quad (15)$$

where the effective breadth at the throat,  $b_e$ , the effective gauged head upstream,  $h_e$ , and the coefficient of velocity,  $C_v$ , are given by:

$$b_e = b - 2\delta^* \quad (16)$$

$$h_e = h - \delta^* \quad (17)$$

$$C_v = \left(\frac{H_e}{h_e}\right)^{3/2} \quad (18)$$

Defined in this way,  $C_v$  is a dimensionless coefficient allowing for the effect of approach velocity on the measured water level upstream of the weir.

**9.2.6** The basic discharge equation for rectangular throated flumes, Formula (15), may also be written in terms of more useful parameters, such as the actual gauged head upstream and the actual flume breadth, as

$$Q = \left(\frac{2}{3}\right)^{3/2} g^{1/2} C_D C_v b h^{3/2} \quad (19)$$

where  $C_D$  is defined as the coefficient of discharge, which takes into account the boundary layer effects, defined by

$$C_D = \left(\frac{b_e}{b}\right) \left(\frac{h_e}{h}\right)^{3/2} \quad (20)$$

Substituting Formulae (16) and (17) into Formula (20) gives:

$$C_D = \left(1 - 2\frac{\delta^*}{L} \times \frac{L}{b}\right) \left(1 - \frac{\delta^*}{L} \times \frac{L}{h}\right)^{3/2} \quad (21)$$

where  $L$  is the length of the prismatic section of the contraction in the flume.

**9.2.7** For most installations with a good surface finish the value of the relative boundary layer displacement thickness,  $\delta^*/L$ , will, in practice, lie in the range 0,002 to 0,004. For rough surface finishes, the value of  $\delta^*/L$  is known to vary with the Reynolds number,  $Re$ , and relative roughness,  $L/k_s$ , as shown in [Figure 9](#). However, for good surface finishes, provided  $10^5 > L/k_s > 4000$  and  $Re > 3 \times 10^5$ ,  $\delta^*/L$  may be assumed equal to 0,003 and Formula (21) then becomes

$$C_D = \left(1 - 0,006\frac{L}{b}\right) \left(1 - 0,003\frac{L}{h}\right)^{3/2} \quad (22)$$

Various values of  $C_D$  derived from this equation are given in [Table 1](#) and these are the values which apply to well-constructed installations as detailed above.

**9.2.8** The user of this International Standard may choose between two options for determining the effect of roughness on the coefficient of discharge,  $C_D$ , when computing discharges through long-throated flumes. A simple boundary layer approach assumes a fixed numerical value for the boundary layer displacement thickness,  $\delta^*$ , whereas a more detailed approach uses a variable boundary layer displacement thickness that depends upon the estimated roughness of the flume throat and the flow conditions. The simple approach may be used for the following applications:

- a) The determination of approximate discharges at an early stage in the design process.
- b) The determination of reasonably accurate discharges for large structures which are compliant in every way with the standard.

The detailed boundary layer option may be used for standard structures under any permitted hydraulic conditions.

**9.2.9** An analogous relationship to Formula (15) can be derived for flumes with trapezoidal throats (see [Figure 5](#)) as:

$$Q = \left(\frac{2}{3}\right)^{3/2} g^{1/2} C_s C_v b_e h_e^{3/2} \quad (23)$$

where

$C_s$  is a numerical coefficient that takes into account the effect of the non-rectangular flow section, and which for a trapezoidal section is given by

$$C_s = f(mH_{ce} / b_e) \quad (24)$$

(see [Figure 10](#) and [11.4.6](#));

$H_{ce}$  is the effective total head at the critical section.

**Table 1 — Discharge coefficients,  $C_D$ , for rectangular-throated flumes**

$C_D = \left(1 - 0,006 \frac{L}{b}\right) \left(1 - 0,003 \frac{L}{h}\right)^{3/2}$														
$\frac{L}{b}$	$\frac{h}{L}$													
	0,70	0,65	0,60	0,55	0,50	0,45	0,40	0,35	0,30	0,25	0,20	0,15	0,10	0,05
0,2	0,992 4	0,991 9	0,991 3	0,990 6	0,989 8	0,988 8	0,987 6	0,986 0	0,983 9	0,980 9	0,976 4	0,969 0	0,954 2	0,910 3
0,4	0,991 2	0,990 7	0,990 1	0,989 4	0,988 6	0,987 6	0,986 4	0,984 8	0,982 7	0,979 7	0,975 2	0,967 8	0,953 0	0,909 2
0,6	0,990 0	0,989 5	0,988 9	0,988 3	0,987 5	0,986 5	0,985 2	0,983 6	0,981 5	0,978 5	0,974 1	0,966 7	0,951 9	0,908 1
0,8	0,988 8	0,988 3	0,987 8	0,987 1	0,986 3	0,985 3	0,984 0	0,982 5	0,980 3	0,977 4	0,972 9	0,965 5	0,950 2	0,907 0
1,0	0,987 6	0,987 2	0,986 6	0,985 9	0,985 1	0,984 1	0,982 9	0,981 3	0,979 2	0,976 2	0,971 1	0,964 4	0,949 6	0,905 9
1,2	0,986 5	0,986 0	0,985 4	0,984 7	0,983 9	0,982 9	0,981 7	0,980 1	0,978 0	0,975 0	0,970 6	0,963 2	0,948 5	0,904 8
1,4	0,985 3	0,984 8	0,984 2	0,983 5	0,982 7	0,981 8	0,980 5	0,978 9	0,976 8	0,973 9	0,969 4	0,962 0	0,947 4	0,903 8
1,6	0,984 1	0,983 6	0,983 1	0,982 4	0,981 6	0,980 6	0,979 3	0,977 8	0,975 7	0,972 7	0,968 3	0,960 9	0,946 2	0,902 7
1,8	0,982 9	0,982 4	0,981 9	0,981 2	0,980 4	0,979 4	0,978 2	0,976 6	0,974 5	0,971 5	0,967 1	0,959 8	0,945 1	0,901 6
2,0	0,981 8	0,981 3	0,980 7	0,980 0	0,979 2	0,978 2	0,977 0	0,975 4	0,973 3	0,970 4	0,966 0	0,958 6	0,944 0	0,900 5
2,2	0,980 6	0,980 1	0,979 5	0,978 9	0,978 1	0,977 1	0,975 8	0,974 3	0,972 2	0,969 2	0,964 8	0,957 5	0,942 9	0,899 5
2,4	0,979 4	0,978 7	0,978 4	0,977 7	0,976 9	0,975 9	0,974 7	0,973 1	0,971 0	0,968 1	0,963 7	0,956 3	0,941 7	0,898 4
2,6	0,978 3	0,977 8	0,977 2	0,976 5	0,975 7	0,974 8	0,973 5	0,972 0	0,969 9	0,966 9	0,962 5	0,955 2	0,940 6	0,897 3
2,8	0,977 1	0,976 6	0,976 1	0,975 4	0,974 6	0,973 6	0,972 4	0,970 8	0,968 7	0,965 8	0,961 4	0,954 1	0,939 5	0,896 3
3,0	0,975 9	0,975 5	0,974 9	0,974 2	0,973 4	0,972 4	0,971 2	0,969 6	0,967 6	0,964 6	0,960 2	0,952 9	0,938 4	0,895 2
3,2	0,974 8	0,974 3	0,973 3	0,973 1	0,972 3	0,971 3	0,970 1	0,968 5	0,966 4	0,963 5	0,959 1	0,951 8	0,937 3	0,894 1
3,4	0,973 6	0,973 1	0,972 6	0,971 9	0,971 1	0,970 1	0,968 9	0,967 3	0,965 3	0,962 3	0,958 0	0,950 7	0,936 2	0,893 1
3,6	0,972 5	0,972 0	0,971 4	0,970 8	0,970 0	0,969 0	0,967 8	0,966 2	0,964 1	0,961 2	0,956 8	0,949 5	0,935 0	0,892 0
3,8	0,971 3	0,970 8	0,970 3	0,969 6	0,968 8	0,967 8	0,966 6	0,965 1	0,963 0	0,960 1	0,955 7	0,948 4	0,933 9	0,890 9
4,0	0,970 2	0,969 7	0,969 1	0,968 5	0,967 7	0,966 7	0,965 5	0,963 9	0,961 8	0,958 9	0,954 6	0,947 3	0,932 8	0,889 9
4,2	0,969 0	0,968 5	0,968 0	0,967 3	0,966 5	0,965 6	0,964 3	0,962 8	0,960 7	0,957 8	0,953 4	0,946 2	0,931 7	0,888 8
4,4	0,967 9	0,967 4	0,966 8	0,966 2	0,965 4	0,964 4	0,963 2	0,961 6	0,959 6	0,956 6	0,952 3	0,945 1	0,930 6	0,887 8
4,6	0,966 7	0,966 3	0,965 7	0,965 0	0,964 2	0,963 3	0,962 1	0,960 5	0,958 4	0,955 5	0,951 2	0,943 9	0,929 5	0,886 7
4,8	0,965 6	0,965 1	0,964 6	0,963 9	0,963 1	0,962 1	0,960 9	0,959 4	0,957 3	0,954 4	0,950 0	0,942 8	0,928 4	0,885 7
5,0	0,964 5	0,964 0	0,963 4	0,962 8	0,962 0	0,961 0	0,959 3	0,958 3	0,956 2	0,953 3	0,949 0	0,941 8	0,927 4	0,884 7

The number of significant figures given in the columns for coefficient of discharge should not be taken to imply a corresponding accuracy but only to assist in interpolation and analysis.

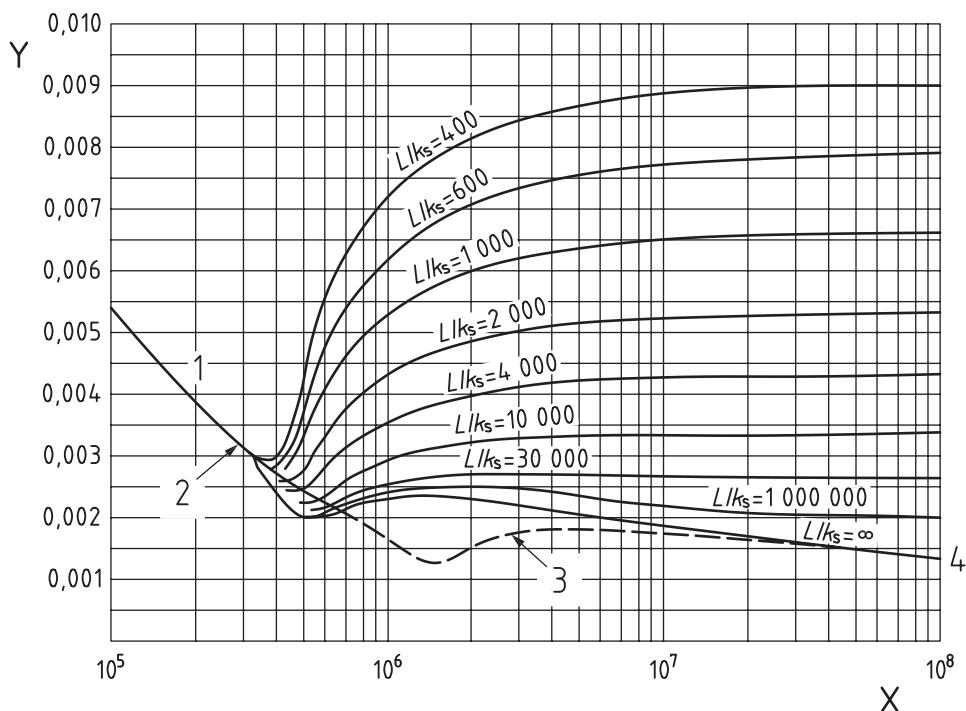

**Key**

- 1 laminar
- 2 transition to turbulent boundary at  $Re = 3 \times 10^5$
- 3 lower limit for smooth laboratory installations
- 4 smooth

X Reynolds number  $Re = \frac{\bar{v}L}{\nu}$

Y relative boundary displacement thickness  $\delta^*/L$

**Figure 9 — Variation of the relative boundary layer displacement thickness,  $\delta^*/L$ , with Reynolds number,  $Re$ , and relative roughness,  $L/k_s$**

**9.2.10** Although theoretical design and flume computation procedures exist utilizing the above equations, they are cumbersome. This is largely because  $C_s$  is dependent on  $H_{ce}$  which may differ significantly from the gauged head,  $h$ . An alternative method of computing the discharge for trapezoidal flumes is given in [11.5](#).

**9.2.11** The corresponding relationship for U-throated flumes (see [Figure 6](#)) is:



$$Q = \left(\frac{2}{3}\right)^{3/2} g^{1/2} C_s C_v D_e h_e^{3/2} \quad (25)$$

where

$C_s$  is a numerical coefficient that takes account of the effect of the non-rectangular flow section, which for a U-shaped section is given by

$$C_s = f(H_{ce} / D_e) \quad (26)$$

(see [Figure 11](#) and [12.4.6](#));

$D_e$  is the effective diameter of the base of the U-shaped throat (defined in a similar manner to  $b_e$  in a rectangular throat).

**9.2.12** Theoretical procedures using the above equations are cumbersome, largely because  $C_s$  is dependent on  $H_{ce}$  which may differ significantly from the gauged head,  $h$ . An alternative method of computing the discharge for U-throated flumes is given in [12.5](#).

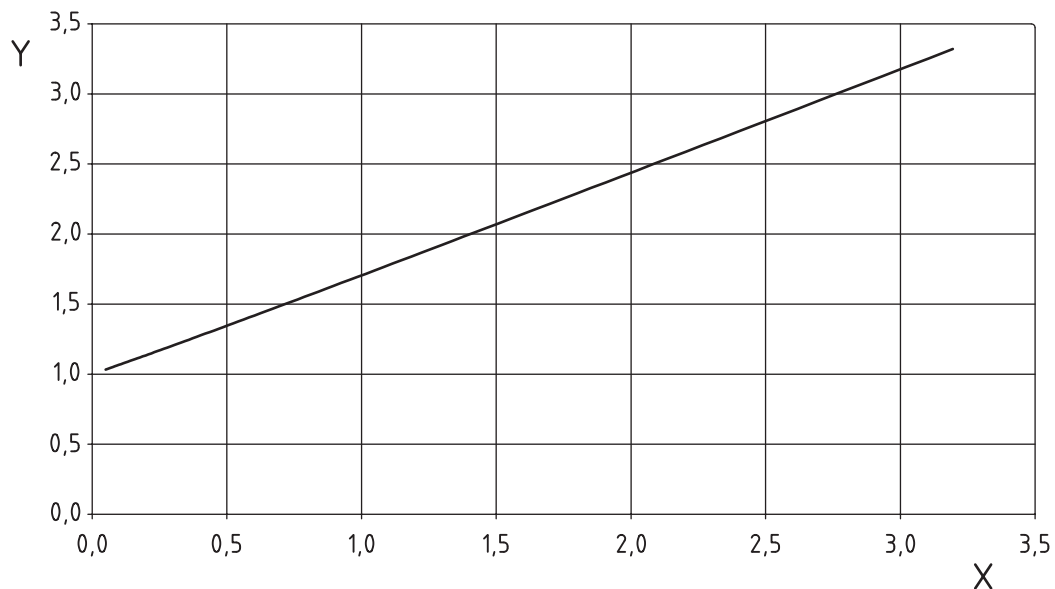

**Key**

X  $mH_e/b_e$

Y shape coefficient,  $C_s$

NOTE This curve is based on a specific case, but is of virtually universal application; curves for other cases can be obtained from the "Shape chart" worksheet of Flume1.xls (see [Annex D](#)).

**Figure 10 — Shape coefficient relationship for trapezoidal-throated flumes**

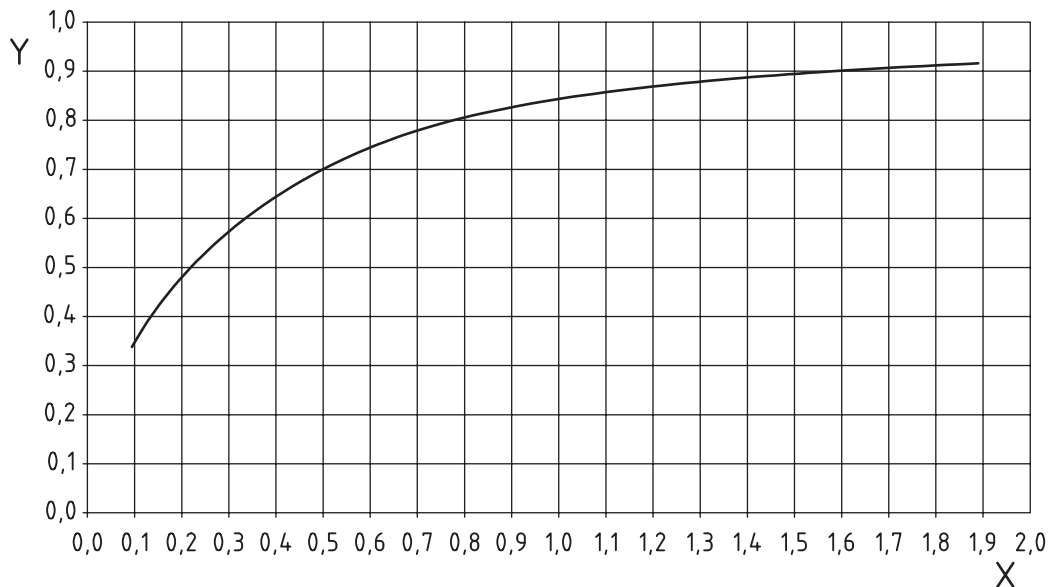

**Key**

X  $H_e/D_e$

Y shape coefficient,  $C_s$

NOTE This curve is based on a specific case, but is of virtually universal application; curves for other cases can be obtained from the “Shape chart” worksheet of Flume2.xls (see [Annex D](#)).

**Figure 11 — Shape coefficient relationship for U-throated flumes**

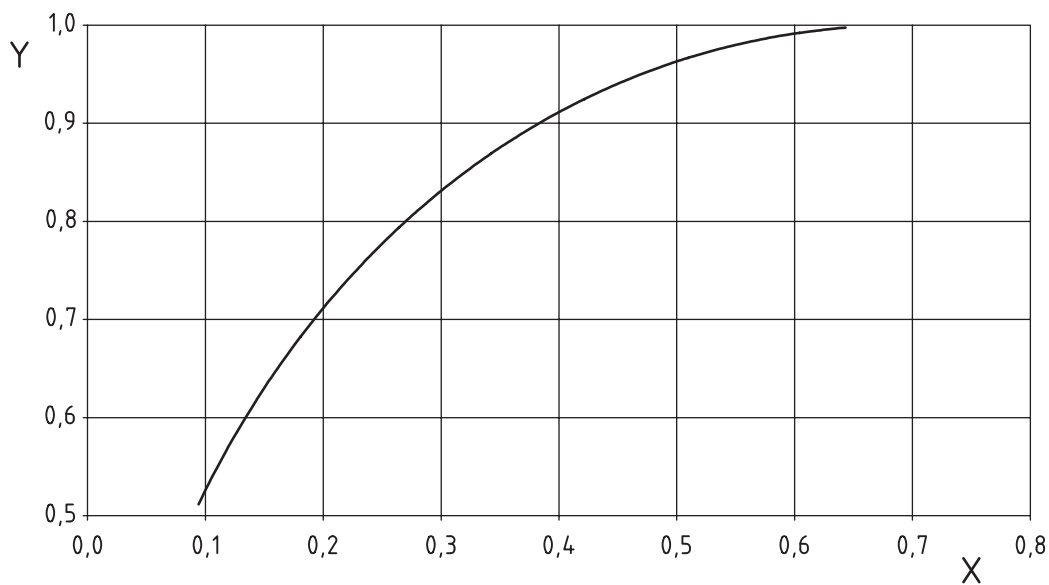

**Key**

X  $H_e/D_e$

Y throat width parameter,  $w_{ce}/D_e$

NOTE This curve is based on a specific case, but is of virtually universal application; curves for other cases can be obtained from the “Throat chart” worksheet of Flume2.xls (see [Annex D](#)).

**Figure 12 — Throat width parameter relationship for U-throated flumes for use in determining Reynolds number**

### 9.3 Calculation of stage-discharge relationships

**9.3.1** In the case of a flume with a rectangular throat, Formula (15) can be used to compute the stage-discharge relationship for the structure. Since Formulae (23) and (25) are not particularly convenient for use in computing these relationships for trapezoidal and U-throated flumes, an alternative approach is suggested. As the rectangular-throated flume is a particular case of the trapezoidal-throated flume (with  $m = 1$ ), the alternative approach for the trapezoidal-throated flume is also a convenient approach for the rectangular-throated flume.

**9.3.2** A theoretical calibration for a gauging structure for the whole range of discharge can be derived by considering flow conditions in the throat of the flume and deducing corresponding heads and discharges. The principle of the method is to select a series of values of  $d_c$ , the critical depth in the throat, and calculate corresponding values of  $H_e$  and  $Q$  using Formulae (27) and (28):

$$H_e = d_{ce} + \frac{v_{ce}^2}{2g} = d_{ce} + \frac{A_{ce}}{2w_{ce}} \quad (27)$$

$$Q = \sqrt{\frac{gA_{ce}^3}{w_{ce}}} \quad (28)$$

**9.3.3** The effective total head,  $H_e$ , can be converted to the total head,  $H$ , which can then be converted to the measured gauged head,  $h$ , all as described in [Clauses 10 to 12](#). Since this method is easy to use, and gives the same answers as those based on the coefficient method, described in [9.2](#), it has been adopted as the preferred methodology for determining the stage-discharge rating in the spreadsheets (see [Annex D](#)) that accompany this International Standard. This approach may also be used to determine single flow values by interpolation of the rating relationship.

### 9.4 Approach velocity and coefficient of velocity

**9.4.1** The total head is related to the gauged head by

$$H_e = h_e + \frac{\alpha \bar{v}_a^2}{2g} \quad (29)$$

where

$\bar{v}_a$  is the mean velocity in the approach channel at the gauging section;

$\alpha$  is the kinetic energy coefficient, which takes account of the fact that the kinetic energy head in the approach channel exceeds the value based on the mean velocity, if the velocity distribution across the section is not uniform.

**9.4.2** In applying the equations in this International Standard, the default value for  $\alpha$  is taken as 1,05. The overall uncertainty of measurement, due to such coefficients, the tolerances in the construction of the flume referred to in [6.2.2](#) and the difficulties in making accurate upstream head measurements, is described in detail in [Clauses 13 and 14](#).

**9.4.3** From Formulae (18) and (29), coupled with Formulae (15) and (23), an implicit relationship for  $C_v$  for trapezoidal and rectangular flumes can be derived as

$$\sqrt{\frac{C_v^{2/3} - 1}{\alpha}} = \frac{2}{3\sqrt{3}} \times \frac{b_e h_e}{A_a} C_s C_v \quad (30)$$

where  $A_a$  is the cross-sectional area of the approach channel flow. For U-throated flumes,  $D_e$  is substituted in place of  $b_e$  in Formula (30).

**9.4.4** For a rectangular approach channel:

$$A_a = B(h+p) \quad (31)$$

where

$B$  is the width of the approach channel;

$p$  is the height of flume invert above the invert of the approach channel.

Values of  $C_v$  for rectangular-throated flumes, derived from Formulae (18), (30) and (31), with the limitation that  $\alpha = 1$ , are given in [Table 2](#).

**9.4.5** For a trapezoidal approach channel:

$$A_a = (h+p)[B + m_a(h+p)] \quad (32)$$

where

$B$  is the bed width of the approach channel;

$m_a$  is the sideslope of the approach channel walls (1: $m_a$ , vertical:horizontal).

**9.4.6** For a U-shaped approach channel:

$$A_a = \frac{\pi}{4} D_a^2 f\left(\frac{h+p}{D_a}\right) \quad (33)$$

where  $D_a$  is the diametrical width of the approach channel.

The detailed geometric treatment of part-circular sections is covered in [Clause 12](#).

## 9.5 Selection of flume size and shape

In order to be able to identify which size and type of flume may be appropriate for a given situation, [Annex A](#) provides a graphical representation of the stage-discharge relationships for rectangular, trapezoidal and U-throated flumes over a range of flume sizes. These rating curves allow for a preliminary assessment to be made of their discharge potential, based on a simplified analysis and fixed coefficients, prior to the undertaking of a detailed design for an individual flume type, based on one of the following three clauses ([Clauses 10](#) to [12](#)).

**Table 2 — Values of velocity coefficients,  $C_v$ , for rectangular-throated flumes**

$\frac{4}{27} \left(\frac{b}{B}\right)^2 \left(\frac{h}{h+p}\right)^2 C_D^2 C_v^2 - C_v^{2/3} + 1 = 0$									
$\frac{b}{B}$	$\frac{h}{h+p} C_D$								
	1,0	0,9	0,8	0,7	0,6	0,5	0,4	0,3	0,2
0,10	1,002 2	1,001 8	1,001 4	1,001 1	1,000 8	1,000 6	1,000 4	1,000 2	1,000 1
0,15	1,005 1	1,004 1	1,003 2	1,002 5	1,001 8	1,001 3	1,000 8	1,000 5	1,000 2
0,20	1,009 1	1,007 3	1,005 8	1,004 4	1,003 2	1,002 2	1,001 4	1,000 8	1,000 4
0,25	1,014 3	1,011 5	1,009 1	1,006 9	1,005 1	1,003 5	1,002 2	1,001 3	1,000 6
0,30	1,020 9	1,016 8	1,013 2	1,010 0	1,007 3	1,005 1	1,003 2	1,001 8	1,000 8
0,35	1,029 0	1,023 2	1,018 1	1,013 7	1,010 0	1,006 9	1,004 4	1,002 5	1,001 1
0,40	1,038 6	1,030 8	1,024 0	1,018 1	1,013 2	1,009 1	1,005 8	1,003 2	1,001 4
0,45	1,050 0	1,039 7	1,030 8	1,023 2	1,016 8	1,011 5	1,007 3	1,004 1	1,001 8
0,50	1,063 5	1,050 0	1,038 6	1,029 0	1,020 9	1,014 3	1,009 1	1,005 1	1,002 2
0,55	1,079 3	1,062 0	1,047 6	1,035 7	1,025 5	1,017 5	1,011 0	1,006 1	1,002 7
0,60	1,098 0	1,076 0	1,057 9	1,042 9	1,030 8	1,020 9	1,013 2	1,007 3	1,003 2
0,65	1,120 3	1,092 1	1,069 5	1,051 3	1,036 7	1,024 8	1,015 6	1,008 6	1,003 8
0,70	1,146 5	1,110 8	1,082 9	1,060 6	1,042 9	1,029 0	1,018 1	1,010 0	1,004 4
0,75		1,132 7	1,098 0	1,071 1	1,050 0	1,033 6	1,020 9	1,011 5	1,005 1
0,80			1,115 3	1,082 9	1,057 9	1,038 6	1,024 0	1,013 2	1,005 8
0,85			1,135 5	1,096 0	1,066 4	1,044 1	1,027 2	1,014 9	1,006 5
0,90				1,110 8	1,076 0	1,050 0	1,030 8	1,016 8	1,007 3
0,95				1,127 5	1,086 4	1,056 4	1,034 6	1,018 8	1,008 2
1,00				1,146 5	1,098 0	1,063 5	1,038 6	1,020 9	1,009 1

The number of significant figures given in the columns for coefficient of velocity should not be taken to imply a corresponding accuracy but only to assist in interpolation and analysis.

## 10 Rectangular-throated flume

### 10.1 Description

**10.1.1** The rectangular throated flume consists of a constriction of rectangular cross-section disposed about symmetrically with respect to the approach channel. This is a common type of flume and the easiest to construct but cannot be adapted to suit non-rectangular channels when loss of head is important.

**10.1.2** There are three types of rectangular throated flume:

- a) with side contractions only;
- b) with bottom contraction or hump only;
- c) with both side and bottom contractions.

The type to be used depends on downstream conditions at various rates of flow, the maximum rate of flow, the permissible head loss and limitations of the  $h/b$  ratio, and whether or not the stream carries sediment.

**10.1.3** The invert of the throat shall be level throughout its width and length. The sides of the flume throat shall be vertical and parallel and square with the invert, so that the width of the throat is accurate from top to bottom and end to end. The surfaces of the throat and entrance transition shall be smooth; they may be constructed in concrete with a smooth finish, or lined with a smooth non-corrodible material. (In laboratory applications rigid plastic, metal surfaces and painted timber sheet material are commonly deployed.) The centreline of the throat shall be in line with the centreline of the approach channel. In the case of flumes without a hump (bottom contraction), the floor of the approach channel shall be level, and at no point higher than the invert of the throat, for a distance of at least  $2h_{\max}$  upstream of the head measurement section.

**10.1.4** The flume geometry shall be as shown in [Figure 4](#). The radius of the curved transition to the bed and walls of the throat shall be at least  $4p$  and  $2(B - b)$  respectively. The 1 in 6 expansion beyond the throat may be truncated when recovery of head is not important.

**10.1.5** When the required recovery of head is more than 80 %, the alternative flume geometry with side and bottom contractions can be used. The slope downstream of the throat shall be 1 in 20 for a length of  $2H$  (where  $H$  is the total head above the sill of the hump) beyond which it may be steeper. The length of the sidewalls downstream of throat shall be  $4H$  and their divergence shall be 1 in 10. For greater recovery of heads, the sidewalls shall be parallel up to the toe of the slope and then a hyperbolic expansion should be given up to the point where the downstream channel begins.

### 10.2 Location of head measurement section

The head on the flume shall be measured at a point far enough upstream of the contraction to be clear of the effect of drawdown, but close enough to ensure that the energy loss between the section of measurement and the throat will be negligible. It is recommended that the head measurement section be located a distance of between 3 and 4 times the proposed maximum gauged head upstream of the leading edge of the entrance transition.

### 10.3 Provision for modular flow

**10.3.1** Flow is modular when it is independent of variations in tailwater level, and for this to be so, the velocity in the throat has to be the critical velocity. The invert level shall therefore be at such an elevation as to produce modular flow for the full range of design discharges. The dimensions of the flume shall be such that the total head upstream (relative to throat invert) is at least 1,25 times that downstream (assuming subcritical flow exists downstream) at all rates of flow. Nevertheless, it may be possible to

reduce this difference, provided that the occurrence of free discharge is confirmed. On the other hand, if the expansion is truncated, the ratio shall be at least 1,33.

**10.3.2** In artificial channels it is frequently possible to determine the depth downstream at various rates of flow with reasonable accuracy, for example by means of a standard resistance formula if the channel is long enough and of constant slope or by reference to the characteristics of controlling features downstream.

**10.3.3** If the flume is to be installed in an existing channel or stream the following information should then be obtained at the site:

- a) the maximum depth recorded with an estimate of the rate of flow at that depth;
- b) the approximate depths at two or more intermediate rates of flow;
- c) the dead water level in the stream, i.e. the level under zero flow conditions.

## 10.4 Evaluation of discharge for a given observed upstream head

**10.4.1** The basic discharge equation for rectangular throated flumes is given by Formula (19) in [Clause 9](#) as

$$Q = \left(\frac{2}{3}\right)^{3/2} g^{1/2} C_D C_v b h^{3/2} \quad (34)$$

where

$$C_D = \left(\frac{b_e}{b}\right) \left(\frac{h_e}{h}\right)^{3/2} \quad (35)$$

$$b_e = b - 2\delta^* \quad (36)$$

$$h_e = h - \delta^* \quad (37)$$

**10.4.2** Substituting Formulae (36) and (37) into Formula (35), the modular discharge coefficient,  $C_D$ , is given by

$$C_D = \left(1 - 2\frac{\delta^*}{L} \times \frac{L}{b}\right) \left(1 - \frac{\delta^*}{L} \times \frac{L}{h}\right)^{3/2} \quad (38)$$

where  $L$  is the length of prismatic section of the contraction at the flume and  $\delta^*$  is the boundary layer displacement thickness at the end of the throat.

**10.4.3** For installations with a good surface finish the value of  $\delta^*/L$  will, in practice, lie in the range 0,002 to 0,004. For rough surface finishes, the value of the relative boundary layer displacement thickness,  $\delta^*/L$ , varies with the Reynolds number,  $Re$ , and relative roughness,  $L/k_s$ , as shown in [Figure 9](#). For good surface finishes, provided  $10^5 > L/k_s > 4000$  and  $Re > 3 \times 10^5$ ,  $\delta^*/L$  may be assumed equal to 0,003 and Formula (38) then becomes

$$C_D = \left(1 - 0,006\frac{L}{b}\right) \left(1 - 0,003\frac{L}{h}\right)^{3/2} \quad (39)$$

**10.4.4** The value of the modular discharge coefficient is obtained by substituting known values of  $L$ ,  $b$  and  $h$  into Formula (38) or (39). Various values of  $C_D$  derived from this equation are given in [Table 1](#) and these are the values which apply to well constructed installations as detailed above.

**10.4.5** The Reynolds number, which is needed for the detailed boundary layer treatment, is calculated from

$$Re \approx \frac{L}{\nu} \left( \frac{gQ}{b} \right)^{1/3} \quad (40)$$

**10.4.6** The value of  $C_v$  is computed from Formulae (30) and (31).

**10.4.7** In order to apply the coefficient method to determine the discharge,  $Q$ , corresponding to a specific gauged head,  $h$ , an iterative approach is required. This is most conveniently accomplished using the spreadsheet for trapezoidal and rectangular flumes in the Flume1.xls file (see [Annex D](#)) that accompanies this International Standard. The solution scheme adopted for the coefficient method in the spreadsheet is given below and this approach is recommended for manual calculations.

**10.4.8** The following basic geometry and parameters are entered into the input data cells of the spreadsheet:

- $m$  sideslope of throat section (set to 0 for a rectangular-throated flume);
- $m_a$  sideslope of approach channel at gauging section (set to 0 if the approach channel is also rectangular);
- $b$  width of throat;
- $B$  base width of approach channel at gauging section;
- $p$  height of throat invert above approach channel bed;
- $L$  length of throat;

together with the gauged head,  $h$ , for which discharge is to be computed.

**10.4.9** The spreadsheet also requires the user to choose between

- the simple boundary layer treatment, with a fixed value of the dimensionless boundary layer displacement thickness,  $\delta^*/L$ , and
- the detailed boundary layer treatment.

If the detailed treatment is chosen, an additional input item, the roughness amplitude,  $k_s$ , is required (recommended values are shown in [Table 3](#)).



**Table 3 — Recommended roughness values,  $k_s$**

Surface classification	Values of $k_s$ mm	
	Good example	Normal value
<b>Plastics (and similar)</b>		
Perspex, PVC or other smooth-faced plastics	—	0,003
Asbestos cement	—	0,015
Resin-bonded, glass fibre moulded against smooth forms of sheet metal or well-sanded and painted timber	0,03	0,06
<b>Metal</b>		
Smooth, machined and polished metal	0,003	0,006
Uncoated sheet metal, rust free	0,015	0,03
Painted sheet metal	0,03	0,06
Galvanized metal	0,06	0,15
Painted or coated casting	0,15	0,15
Uncoated casting	—	0,3
<b>Concrete</b>		
In-situ or precast construction using steel formwork, with all irregularities rubbed down or filled in	0,06	0,15
In-situ or precast construction using plywood or wrought timber formwork	0,3	0,6
Smooth trowelled cement rendering	0,3	0,6
Concrete with thin film or sewage slime	0,6	1,5
<b>Wood</b>		
Planed timber or plywood	0,3	0,6
Well sanded and painted	0,03	0,06

**10.4.10** Default values of the following parameters are given in the spreadsheet, but may be changed by the user:

- $g$  gravitational acceleration (default value of  $9,807 \text{ ms}^{-2}$ );
- $\nu$  kinematic viscosity of water, required only for the detailed boundary layer treatment (default value of  $1,14 \times 10^{-6} \text{ m}^2\text{s}^{-1}$  for water at  $15^\circ\text{C}$  entered, but other values may be derived from [Table 4](#));
- $\alpha$  kinetic energy coefficient for approach channel (default value 1,05);
- $\delta^*/L$  dimensionless boundary layer displacement thickness for simple boundary layer treatment (default value 0,003);
- $C_v$  value of velocity coefficient to use in the first iteration (default value 1,05).

**Table 4 — Kinematic viscosity of water and its variation with temperature**

Temperature	Kinematic viscosity
°C	$\text{m}^2/\text{s} \times 10^{-6}$
0	1,79
5	1,52
10	1,31
15	1,14
20	1,01
25	0,90
30	0,81

**10.4.11** The spreadsheet then proceeds with the calculations, using the solution sequence set out in the table below. Successive iteration results are set out in tabular form, with each column containing an individual iteration, so that the user can see that the iterations have successfully converged. The spreadsheet includes five iterations.

Step	Description	Parameter	Formula
1	Area of approach channel (non-iterative)	$A_a$	(32)
2	Numerical coefficient related to throat sideslope (non-iterative, equals 1,0 for a rectangular-throated flume)	$\eta$	(48)
3	Relative boundary layer displacement thickness (default value taken for first two iterations)	$\delta^*/L$	—
4	Discharge coefficient	$C_D$	(38), (49)
5	Velocity coefficient (default value for first iteration, then value from previous iteration)	$C_v$	—
6	Intermediate parameter (zero for rectangular-throated flume)	$mH/b$	—
7	Throat flow width parameter (unity for rectangular-throated flume)	$w_c/b$	—
8	Reynolds number	$Re$	(40), (51)
9	Boundary layer displacement thickness (calculated from Reynolds number and throat length in worksheet 'Delta-star')	$\delta^*$	—
10	Effective gauged head	$h_e$	(37), (47)
11	Effective total head	$H_e$	(18)
12	Effective throat bed width	$b_e$	(36), (46)
13	Intermediate parameter (zero for rectangular-throated flume)	$mH_e/b_e$	—
14	Shape coefficient (unity for rectangular-throated flume)	$C_s$	—
15	Intermediate parameter (used in step 16)	$C_s b_e h_e/A_a$	—
16	Velocity coefficient (computed from $\alpha$ , $A_a$ , current values of $C_s$ , $b_e$ , $h_e$ and value of $C_v$ at previous iteration)	$C_v$	(30)
17	Discharge	$Q$	(34), (44)

**10.4.12** Although the full procedure described above is recommended for determining the discharge for a specific gauged head, for *preliminary* design purposes only, in the case of the flume shown in [Figure 4](#), the discharge equation can be expressed approximately by

$$Q = \left(\frac{2}{3}\right)^{3/2} g^{1/2} C b H^{3/2} \quad (41)$$

where  $C$  is an overall discharge coefficient and for preliminary design purposes may be assumed to have a value between 0,97 and 1,00.

**10.4.13** In cases where the approach channel section is not truly rectangular or trapezoidal at the location where  $h$  is measured,  $b$  can be determined from

$$b = \frac{A_a}{h+p} \quad (42)$$

where  $A_a$  is the actual cross-sectional area of the approach channel at that location and water level.

## 10.5 Computation of stage-discharge relationship

**10.5.1** The stage-discharge relationship for a rectangular-throated flume can be computed, albeit laboriously, by repeated application of the coefficient method at successive gauged heads. A more convenient approach, however, is to consider a series of values of the critical depth in the throat. For each depth, all the geometric dimensions at the throat are then adjusted for boundary layer effects by reducing them according to the displacement thicknesses, as shown in [Figure 8](#). Standard hydraulic flow theory is then applied to obtain the critical discharge and effective head, to which is added the displacement thickness to obtain the total head. Finally, this is converted to the gauged head by subtracting the velocity head in the approach channel, this last step being an iterative calculation.

**10.5.2** Because the rectangular-throated flume is a particular form of the trapezoidal-throated flume (with the sideslope,  $m = 0$ ), the user of this International Standard is referred to [11.5](#), where the latter procedure for the computation of the stage-discharge relationship is fully described. These calculations are most conveniently accomplished using the spreadsheet for trapezoidal and rectangular flumes in the Flume1.xls file (see [Annex D](#)) that accompanies this International Standard.

## 10.6 Limits of application

**10.6.1** The practical lower limit of  $h$  is related to the magnitude of the influence of fluid properties and boundary roughness. The recommended lower limit of 0,05 m or 0,05L, whichever is the greater.

**10.6.2** There is also a limit on the ratio of the areas of the approach channel and the throat arising from difficulties experienced when the Froude number in the approach channel exceeds about 0,5. The recommended upper limit of the nominal area ratio  $bh/[B(h+p)]$  is 0,7. The “Rating” worksheet within the spreadsheet for trapezoidal and rectangular flumes in the Flume1.xls file (see [Annex D](#)) that accompanies this International Standard tabulates values of the Froude number and selected values are also included in the “Summary” worksheet.

**10.6.3** Other limitations are as follows.

- a) The bed width,  $b$ , shall be not less than 0,10 m.
- b) The ratio  $h/b$  shall be not more than 3.
- c) The ratio  $h/L$  should not exceed 0,50.

**10.6.4** The above limitation on  $h/L$  arises from the necessity to ensure parallel flow conditions at the critical section in the throat. However, the ratio  $h_{\max}/L$  may be allowed to rise to 0,67, with an additional uncertainty in coefficient of 2 % over that derived by Formula (43).

**10.6.5** The previous edition of this International Standard (ISO 4359:1983) required that the gauged head,  $h$ , be not more than 2 m. However, there is no technical justification for this restriction, so it does not apply in the present edition.

**10.6.6** The overall uncertainty of measurement, due to experimentally determined coefficients, the tolerances in the construction of the flume referred to in [6.2.2](#) and the difficulties in making accurate upstream head measurements, is described in detail in [Clauses 13](#) and [14](#).

**10.6.7** With reasonable skill and care in the construction of the flume, the coefficients are expected to have an uncertainty approaching 1 % in favourable circumstances, for example when  $C_D$  and  $C_V$  are not far from unity. An estimate of the standard percentage uncertainty of the discharge coefficient  $u^*(C)$  may be obtained from

$$u^*(C) = \pm [1 + 20(C_V - C_D)] \% \quad (43)$$

## 11 Trapezoidal-throated flumes

### 11.1 Description

**11.1.1** Trapezoidal throated flumes can be designed to cope with many different flow conditions, and the optimum throat geometry (in terms of bed width and sideslope) will depend on the range of flow to be measured and on the characteristics of the stream or channel in which it is to be installed.

**11.1.2** Trapezoidal throated flumes should have geometry generally as indicated in [Figure 5](#). In some circumstances, however, it will be appropriate to make the invert of the throat level with the invert of the approach channel, i.e.  $p = 0$ , for example if sediment has to be conveyed through the flume. This International Standard covers only that class of trapezoidal throated flume in which the sloping walls of both the throat and the approach channel (at the gauging location) extend above the highest water levels.

**11.1.3** The flume shall be installed with the throat centreline in line with the centre of the approach channel. Subcritical flow shall exist in the flume approach, and the flume shall be installed at such an elevation as to operate with free discharge throughout the range. The surfaces of the flume shall be of smooth concrete, stainless steel or other smooth non-corrodible material. The throat section is of particular importance and shall have a level invert and be truly prismatic, the sloping walls being plane surfaces, symmetrically disposed and making a sharp intersection with the invert of the throat.

**11.1.4** The entrance and exit transitions may be plane or curved surfaces to suit convenience of construction.

**11.1.5** The convergence of the entrance transition on any plane section, if formed from plane surfaces, should not be angled more severely than 1 in 3 (transverse to horizontal) at each side. If curved surfaces are used, these shall be well-streamlined, for example by using the face of inclined cylinders, or a skew cylinder, or a vertical-axis cone. The surfaces shall lie entirely on the channel centreline side of planes defining a 1 in 3 convergence on each side, and if curved shall terminate truly tangential to the planes forming the throat.

**11.1.6** The surfaces forming the exit transition shall lie entirely inside planes defining a 1 in 3 expansion on each side. An expansion of 1 in 6 gives very good recovery of head and a high modular limit.

### 11.2 Location of head measurement section

The gauged head of the flume shall be measured at a point far enough upstream of the contraction to be clear of the effects of drawdown, but close enough to ensure that the energy loss between the section of measurement and the throat is negligible. It is recommended that the head measurement section

be located a distance of between 3 and 4 times the proposed maximum gauged head upstream of the leading edge of the entrance transition.

### 11.3 Provision for modular flow

**11.3.1** Flow is modular when it is independent of variations in tailwater level, and for this to be so, the velocity shall pass through the critical velocity in the throat. The invert level shall therefore be at such an elevation as to produce modular flow for the full range of design discharges. The dimensions of the flume shall be such that the total head upstream is well in excess of that downstream when related to the invert of the throat (assuming subcritical flow exists downstream).

**11.3.2** As the modular limit is dependent on head recovery beyond the throat, the necessary ratio of upstream to downstream head is dependent on the angle of expansion, as follows:

$$1 \text{ in } 20 \text{ each side} \quad H/H_d \geq 1,10$$

$$1 \text{ in } 10 \text{ each side} \quad H/H_d \geq 1,20$$

$$1 \text{ in } 6 \text{ each side} \quad H/H_d \geq 1,25$$

$$1 \text{ in } 3 \text{ each side} \quad H/H_d \geq 1,35$$

where  $H_d$  is the total head just beyond the exit transition, related to the flume invert.

**11.3.3** In artificial channels it is frequently possible to determine the depth downstream at various rates of flow with reasonable accuracy, for example by means of a standard resistance formula if the channel is long enough and of constant slope, or by reference to the characteristics of controlling features downstream.

**11.3.4** If the flume is to be installed in an existing channel or stream, the following information should then be obtained at the site:

- a) the maximum depth recorded with an estimate of the rate of flow at that depth.
- b) the approximate depths at two or more intermediate rates of flow.
- c) the dead water level in the stream, i.e. the level under zero flow conditions.

### 11.4 Evaluation of discharge — Coefficient method

**11.4.1** The basic discharge equation for trapezoidal-throated flumes is given by Formula (23) in [Clause 9](#), with the breadth,  $b$ , replacing the effective breadth,  $b_e$ , the upstream gauged head,  $h$ , replacing the effective head,  $h_e$ , and the introduction of the coefficient of discharge,  $C_D$ , to give

$$Q = \left(\frac{2}{3}\right)^{3/2} g^{1/2} C_D C_s C_v b h^{3/2} \quad (44)$$

where

$$C_D = \left(\frac{b_e}{b}\right) \left(\frac{h_e}{h}\right)^{3/2} \quad (45)$$

$$b_e = b - 2\eta\delta^* \quad (46)$$

$$h_e = h - \delta^* \quad (47)$$

$$\eta = \sqrt{1+m^2} - m \quad (48)$$

and

$\delta^*$  is the boundary layer displacement thickness;

$m$  is the slope of flume sides ( $m$  horizontal to 1 vertical).

**11.4.2** The modular discharge coefficient,  $C_D$ , is given by an expression analogous to that for a rectangular flume given in Formula (38):

$$C_D = \left(1 - 2\eta \frac{\delta^*}{L} \times \frac{L}{b}\right) \left(1 - \frac{\delta^*}{L} \times \frac{L}{h}\right)^{3/2} \quad (49)$$

**11.4.3** For installations with a good surface finish the value of  $\delta^*/L$  will, in practice, lie in the range 0,002 to 0,004. For rough surface finishes, the value of the relative boundary layer displacement thickness,  $\delta^*/L$ , varies with Reynolds number,  $Re$ , and relative roughness,  $L/k_s$ , as shown in [Figure 9](#). For good surface finishes, provided  $10^5 > L/k_s > 4\,000$  and  $Re > 3 \times 10^5$ ,  $\delta^*/L$  may be assumed equal to 0,003 and Formula (49) then becomes

$$C_D = \left(1 - 0,006\eta \frac{L}{b}\right) \left(1 - 0,003 \frac{L}{h}\right)^{3/2} \quad (50)$$

**11.4.4** The value of  $\eta$  is obtained from Formula (48) and the value of the modular discharge coefficient is obtained by substituting known values of  $\eta$ ,  $L$ ,  $b$  and  $h$  into Formula (49) or (50).

**11.4.5** The Reynolds number, which is needed for the detailed boundary layer treatment, is calculated from

$$Re \approx \frac{L}{\nu} \left(\frac{gQ}{b}\right)^{1/3} \left(\frac{b}{w_c}\right)^{1/3} \quad (51)$$

**11.4.6** The shape coefficient,  $C_s$ , is given by Formula (52), which can be derived from Formulae (10) and (23) and the relationship including throat area in Formula (11):

$$C_s = \left[1 + 2 \left(\frac{mh_{ce}}{b_e}\right)\right] \left[ \frac{1 + \left(\frac{mh_{ce}}{b_e}\right)}{1 + \frac{5}{3} \left(\frac{mh_{ce}}{b_e}\right)} \right]^{3/2} \quad (52)$$

**11.4.7** The approach to the solution of  $C_s$  adopted in the spreadsheet is to produce a table and graph of  $C_s$  against  $mH_e/b_e$ , then to look up (interpolating as necessary) the value of  $C_s$  corresponding to the computed value of  $mH_e/b_e$ . Although this relationship varies very slightly with flume geometry and the value of the boundary layer displacement thickness, this variation was disregarded when applying the coefficient method in the previous edition of this International Standard, as a single graphical relationship was provided for trapezoidal flumes. [Figure 10](#) of the present edition shows a plot of  $C_s$  versus  $mH_e/b_e$  for a typical trapezoidal-throated flume. The table and graph for the specific flume geometry and boundary layer displacement thickness are presented in the “Shape” and “Shape chart” worksheets of the Flume1.xls spreadsheet (see [Annex D](#)) that accompanies this International Standard.

**11.4.8** The value of  $C_v$  is computed from Formulae (30) and (32).

**11.4.9** In order to apply the coefficient method to determine the discharge,  $Q$ , corresponding to a specific gauged head,  $h$ , an iterative approach is required. This is most conveniently accomplished using the spreadsheet for trapezoidal and rectangular flumes in the Flume1.xls file (see [Annex D](#)) that accompanies this International Standard. The solution scheme adopted for the coefficient method in the spreadsheet is given below and this approach is recommended for manual calculations.

**11.4.10** The following basic geometry and parameters are entered into the input data cells of the spreadsheet:

- $m$  sideslope of throat section;
- $m_a$  sideslope of approach channel at gauging section;
- $b$  base width of throat;
- $B$  base width of approach channel at gauging section;
- $p$  height of throat invert above approach channel bed;
- $L$  length of throat;

together with the gauged head,  $h$ , for which discharge is to be computed.

**11.4.11** The spreadsheet also requires the user to choose between

- the simple boundary layer treatment, with a fixed value of the dimensionless boundary layer displacement thickness,  $\delta^*/L$ , and
- the detailed boundary layer treatment.

If the detailed treatment is chosen, an additional input item, the roughness amplitude,  $k_s$ , is required (recommended values are shown in [Table 3](#)).

**11.4.12** Default values of the following parameters are given in the spreadsheet, but may be changed by the user.

- $g$  gravitational acceleration (default value of  $9,807 \text{ ms}^{-2}$ );
- $\nu$  kinematic viscosity of water, required only for the detailed boundary layer treatment (default value of  $1,141 \times 10^{-6} \text{ m}^2\text{s}^{-1}$  for water at  $15^\circ\text{C}$  entered, but other values may be derived from [Table 4](#));
- $\alpha$  kinetic energy coefficient for approach channel (default value 1,05);
- $\delta^*/L$  dimensionless boundary layer displacement thickness for simple boundary layer treatment (default value 0,003);
- $C_v$  value of velocity coefficient to use in the first iteration (default value 1,05).

**11.4.13** The spreadsheet then proceeds with the calculations, using the solution sequence set out in the table below. Successive iteration results are set out in tabular form, with each column containing an individual iteration, so that the user can see that the iterations have successfully converged. The spreadsheet includes five iterations.

Step	Description	Parameter	Formula
1	Area of approach channel (non-iterative)	$A_a$	(32)
2	Numerical coefficient related to throat sideslope (non-iterative)	$\eta$	(48)
3	Relative boundary layer displacement thickness (default value taken for first two iterations)	$\delta^*/L$	—
4	Discharge coefficient	$C_D$	(49)
5	Velocity coefficient (default value for first iteration, then value from previous iteration)	$C_v$	—
6	Intermediate parameter (using values from previous iteration)	$mH/b$	—
7	Throat flow width parameter	$w_c/b$	—
8	Reynolds number	$Re$	(51)
9	Boundary layer displacement thickness (calculated from Reynolds number and throat length in worksheet "Delta-star")	$\delta^*$	—
10	Effective gauged head	$h_e$	(47)
11	Effective total head	$H_e$	(18)
12	Effective throat bed width	$b_e$	(46)
13	Intermediate parameter (used in step 14 for determination of $C_s$ )	$mH_e/b_e$	—
14	Shape coefficient (interpolated from value of $mH_e/b_e$ in "Shape" worksheet)	$C_s$	<a href="#">Figure 10</a>
15	Intermediate parameter (used in step 16)	$C_s b_e h_e/A_a$	—
16	Velocity coefficient (computed from $\alpha, A_a$ , current values of $C_s, b_e, h_e$ and value of $C_v$ at previous iteration)	$C_v$	(30)
17	Discharge	$Q$	(44)

## 11.5 Computation of stage-discharge relationship

**11.5.1** The stage-discharge relationship for a trapezoidal-throated flume is most conveniently obtained by considering a series of values of the critical depth in the throat. For each depth, all the geometric dimensions at the throat are then adjusted for boundary layer effects by reducing them according to the displacement thicknesses, as shown in [Figure 8](#). Standard hydraulic flow theory is then applied to obtain the critical discharge and effective head, to which is added the displacement thickness to obtain the total head. Finally, this is converted to the gauged head by subtracting the velocity head in the approach channel, this being an iterative calculation.

**11.5.2** The process is explained in more detail below, based on the simple boundary layer treatment, in which the value of  $\delta^*/L$  is fixed. For the detailed boundary layer treatment, the value of  $\delta^*$  depends on the Reynolds number, which is not available at the start of the calculations, so there is an additional element of iteration.

**11.5.3** Select a range of values of  $d_c$ , the critical depth in the throat (a roughly logarithmic series being more convenient than an arithmetic one) and for each value of  $d_c$  proceed as follows.

- Deduct the boundary layer thickness,  $\delta^*$ , to obtain the effective critical depth,  $d_{ce}$ .
- Calculate the effective bed width,  $b_e$ , from Formula (46).
- Calculate the effective surface width and effective area from Formulae (53) and (54):

$$w_{ce} = b_e + 2md_{ce} \quad (53)$$

$$A_{ce} = (b_e + md_{ce})d_{ce} \quad (54)$$



- d) Calculate  $Q$  using Formula (28).
- e) Calculate  $H_e$  using Formula (27).

**11.5.4** Because the datum for the effective total head,  $H_e$ , is  $\delta^*$  above the flume invert, this is then added back to  $H_e$  to obtain the actual total head,  $H$ .

**11.5.5** The final stage of the process requires the velocity head in the approach channel to be deducted from the total head,  $H$ , to obtain the gauged head,  $h$ , as in

$$h = H - \alpha \frac{\bar{v}_a^2}{2g} \quad (55)$$

where  $\bar{v}_a$  is the mean velocity in the approach channel at the gauging section.

**11.5.6** In applying Formula (55), the cross-sectional area,  $A_a$ , of the approach channel, which is assumed here to be trapezoidal, is given by

$$A_a = (h + p) [B + m_a (h + p)] \quad (56)$$

where

- $p$  is the height of the flume throat invert above the approach channel invert at the gauging section;
- $B$  is the bed width of the approach channel;
- $m_a$  is its sideslope ( $m_a$  horizontal to 1 vertical).

**11.5.7** Because  $h$  occurs implicitly in the right-hand side of Formula (55), a method of successive approximation is needed to determine  $h$ . In the first iteration,  $h$  is approximated to  $H$  for the purposes of calculating  $A_a$  and thence the mean velocity and velocity head. Formula (55) is then used to obtain the first approximation to  $h$ , which is then used at the start of the second iteration. The iterations proceed until there is a negligible difference between successive approximations for the gauged head,  $h$ .

**11.5.8** Having thus worked out pairs of values of  $Q$  and  $h$  for a series of values of  $d_c$ , the rating curve for the flume may be plotted to a suitable scale. Conventionally, rating curves are plotted to linear scales, as adopted in the "Rating chart" worksheet of the spreadsheet for rectangular and trapezoidal flumes in the Flume1.xls file (see [Annex D](#)) that accompanies this International Standard. Alternatively, plotting with logarithmic scales renders the curve closer to a straight line, which may be of assistance when interpolating values from it. Logarithmic plotting may also offer improved sensitivity for low heads and flows.

**11.5.9** The key steps used for the rating calculations in the "Rating" worksheet of the spreadsheet for rectangular and trapezoidal flumes presented in Flume1.xls (see [Annex D](#)) are set out below. Successive iteration results are set out in tabular form, with each column containing an individual iteration, so that the user can see that the iterations have successfully converged. The spreadsheet includes four iterations to obtain the gauged head from the total head, but only one iteration for the boundary layer displacement thickness when using the detailed boundary treatment.

Step	Description	Parameter	Formula
(a)	Numerical coefficient related to throat sideslope (equals 1,0 for a rectangular-throated flume)	$\eta$	(48)
(b)	Effective throat bed width	$b_e$	(46)
(c)	Minimum critical depth in throat taken as 0,03m	$d_c(\text{min})$	—
(d)	Estimated maximum permissible critical depth in throat, increased by 5 %	$d_c(\text{max})$	—
(e)	Range of critical depths divided into a series of 100 increments that follow an approximately logarithmic series	—	—
(f)	The 101 values of critical depth are listed in a column at the left side of the worksheet	$d_c$	—
(g)	Deduct the boundary layer displacement thickness (based on the simple theory) from $d_c$ to obtain the effective value	$d_{ce}$	—
(h)	Effective surface width	$w_{ce}$	(53)
(i)	Effective flow area	$A_{ce}$	(54)
(j)	Critical flow in throat	$Q$	(28)
(k)	Reynolds number	$Re$	(51)
(l)	Boundary layer displacement thickness (calculated from Reynolds number and throat length in worksheet “Delta-star”)	$\delta^*$	—
(m)	Steps (b) and (g) to (j) are repeated using the value of $\delta^*$ obtained in step (l)	$b_e, d_{ce}, w_{ce}, A_{ce}, Q$	See above
(n)	Critical flow velocity in throat = $Q/A_{ce}$	$v_{ce}$	—
(o)	Effective total head	$H_e$	(27)
(p)	Total head = $H_e + \delta^*$	$H$	—
(q)	Gauged head (iterative calculation as described in 11.5.7)	$h$	(55)
(r)	Froude number in approach channel (for information)	$Fr$	(57)

## 11.6 Limits of application

**11.6.1** The practical lower limit of  $h$  is related to the magnitude of the influence of fluid properties and boundary roughness. The recommended lower limit of 0,05 m or 0,05 $L$ , whichever is the greater.

**11.6.2** There is also a limit on the ratio of the areas of the approach channel and the throat arising from difficulties experienced when the Froude number in the approach channel exceeds about 0,5. This shall be checked at each end of the range and at intermediate flows using Formula (57). The “Rating” worksheet of Flume1.xls tabulates values of the Froude number, and selected values are also included in the “Summary” worksheet.

$$Fr_a = \bar{v}_a \sqrt{\frac{\alpha w_a}{g A_a}} = Q \sqrt{\frac{\alpha w_a}{g A_a^3}} \leq 0,5 \quad (57)$$

**11.6.3** Other limitations are as follows.

- The bed width,  $b$ , shall be not less than 0,10 m.
- The ratio  $h/b$  shall be not more than 3.
- The ratio  $h/L$  should not exceed 0,50.
- At all elevations, the width between the throat walls shall be less than the width between the approach channel walls at the same elevation, i.e. there shall be a contraction wherever the water surface lies.

- e) The sloping walls of the throat shall continue upwards without change of slope far enough to contain the maximum discharge to be measured.

**11.6.4** The above limitation on  $h/L$  arises from the necessity to ensure parallel flow conditions at the critical section in the throat. However, the ratio  $h_{\max}/L$  may be allowed to rise to 0,67, with an additional uncertainty in coefficient of 2 % over that derived by Formula (58).

**11.6.5** The previous edition of this International Standard (ISO 4359:1983) required that the gauged head,  $h$ , be not more than 2 m. However, there is no technical justification for this restriction, so it does not apply in the present edition.

**11.6.6** The overall uncertainty of measurement, due to experimentally determined coefficients, the tolerances in the construction of the flume referred to in 6.2.2 and the difficulties in making accurate upstream head measurements, is described in detail in [Clauses 13](#) and [14](#).

**11.6.7** With reasonable skill and care in the construction of the flume, the coefficients are expected to have an uncertainty approaching 1 % in favourable circumstances, for example when  $C_D$  and  $C_V$  are not far from unity. An estimate of the standard percentage uncertainty of the discharge coefficient,  $u^*(C)$ , may be obtained from

$$u^*(C) = \pm [1 + 20(C_V - C_D)]\% \quad (58)$$

## 12 U-throated (round-bottomed) flumes

### 12.1 Description

**12.1.1** Flumes with their inverts in the form of a semi-cylindrical surface with a horizontal axis cannot cope with such a wide variety of situations as the trapezoidal-throated flume, but they have advantages over the rectangular-throated flume in certain circumstances, for example in sewerage systems where the flow enters from a circular or U-shaped conduit. The sensitivity of a U-throated flume is greater than that of a rectangular throated flume, especially in the lower range of discharge lying within the lower semi-cylinder.

**12.1.2** U-throated flumes shall have a geometry generally as indicated in [Figure 6](#). Two basic types are often deployed when the approach channel is U-shaped also:

- a) a level invert arrangement in which no rise in invert level occurs at the throat;
- b) a raised invert level, in which the rise,  $p$ , in invert level is half the difference in the diametrical widths of the approach channel and throat.

The former has advantages where heavy sediments are carried; the latter has the advantage of a simpler transition geometry. The spreadsheet for U-throated flumes included in this International Standard allows any (non-negative) value of  $p$  to be used.

**12.1.3** The flume shall be installed with the throat centreline in line with the centre of the approach channel. Subcritical flow shall exist in the flume approach, and the flume shall be installed at such an elevation as to operate with free discharge throughout the range. The surfaces of the flume shall be of smooth concrete, stainless steel or other smooth non-corrodible material. The throat section is of particular importance and shall have a level invert and be truly prismatic. The lower part shall accurately conform to the surface of a semi-cylinder, and the walls shall be plane vertical surfaces parallel to the axis of the semi-cylinder, the distance between them accurately matching the invert diameter.

**12.1.4** The lower part of the entrance transition, if formed of a part-conical, or part of a skewed conical, surface shall generate a convergence in any plane radial to the flume axis of not more than 1 in 3. The upper part of the entrance transition, if formed of plane surfaces, shall converge at not more than 1 in 3 at each

side (transverse to horizontal). If curved surfaces are used, these shall be well streamlined, for example generated by circular curves, and shall lie entirely inside the alternative part-conical-part-plane entrance shown by the full lines in [Figure 6](#). They shall terminate truly tangential to the surfaces forming the throat.

**12.1.5** The surfaces forming the exit transition shall lie within surfaces defining a 1 in 3 expansion. A 1 in 6 expansion gives very good recovery of head and a high modular limit.

## 12.2 Location of head measurement section

The gauged head of the flume shall be measured at a point far enough upstream of the contraction to be clear of the effects of drawdown, but close enough to ensure that the energy loss between the section of measurement and the throat is negligible. It is recommended that the head measurement section be located a distance of between 3 and 4 times the proposed maximum gauged head upstream of the leading edge of the entrance transition.

## 12.3 Provision for modular flow

**12.3.1** Flow is modular when it is independent of variations in tailwater level, and for this to be so, the velocity shall pass through the critical velocity in the throat. The invert level shall therefore be at such an elevation as to produce modular flow for the full range of design discharges. The dimensions of the flume shall be such that the total head upstream is well in excess of that downstream when related to the invert of the throat (assuming subcritical flow exists downstream).

**12.3.2** As the modular limit is dependent on head recovery beyond the throat, the necessary ratio of upstream to downstream head is dependent on the angle of expansion as follows:

1 in 6 each side,  $H/H_d \geq 1,24$ , and

1 in 3 each side,  $H/H_d \geq 1,35$ ,

where  $H_d$  is the total head just beyond the exit transition, related to the flume invert.

**12.3.3** In artificial channels it is frequently possible to determine the depth downstream at various rates of flow with reasonable accuracy, for example by means of a standard resistance formula if the channel is long enough and of constant slope, or by reference to the characteristics of controlling features downstream.

**12.3.4** If the flume is to be installed in an existing channel or stream, the following information should then be obtained at the site:

- a) the maximum depth recorded with an estimate of the rate of flow at that depth;
- b) the approximate depths at two or more intermediate rates of flow;
- c) the dead water level in the stream, i.e. the level under zero flow conditions.

## 12.4 Evaluation of discharge — Coefficient method

**12.4.1** The basic discharge equation for U-throated flumes is given by Formula (25) in [Clause 9](#), with the actual throat diameter,  $D$ , replacing the effective diameter,  $D_e$ , the upstream gauged head,  $h$ , replacing the effective head,  $h_e$ , and the introduction of the coefficient of discharge,  $C_D$ , to give

$$Q = \left(\frac{2}{3}\right)^{3/2} g^{1/2} C_D C_s C_v D h^{3/2} \quad (59)$$

where

$$C_D = \left(\frac{D_e}{D}\right) \left(\frac{h_e}{h}\right)^{3/2} \quad (60)$$

$$D_e = D - 2\delta_* \quad (61)$$

$$h_e = h - \delta_* \quad (62)$$

and where  $\delta_*$  is the boundary layer displacement thickness.

**12.4.2** The modular discharge coefficient,  $C_D$ , is given by an expression analogous to that for a rectangular flume given in Formula (38):

$$C_D = \left(1 - 2\frac{\delta_*}{L} \times \frac{L}{D}\right) \left(1 - \frac{\delta_*}{L} \times \frac{L}{h}\right)^{3/2} \quad (63)$$

**12.4.3** For installations with a good surface finish the value of  $\delta_*/L$  will, in practice, lie in the range 0,002 to 0,004. For rough surface finishes, the value of the relative boundary layer displacement thickness,  $\delta_*/L$ , varies with Reynolds number,  $Re$ , and relative roughness,  $L/k_s$ , as shown in [Figure 9](#). For good surface finishes, provided  $10^5 > L/k_s > 4\,000$  and  $Re > 3 \times 10^5$ ,  $\delta_*/L$  may be assumed equal to 0,003 and Formula (63) then becomes

$$C_D = \left(1 - 0,006\frac{L}{D}\right) \left(1 - 0,003\frac{L}{h}\right)^{3/2} \quad (64)$$

**12.4.4** The value of the modular discharge coefficient is obtained by substituting known values of  $L$ ,  $D$  and  $h$  into Formula (63) or (64).

**12.4.5** The Reynolds number, which is needed for the detailed boundary layer treatment, is calculated from

$$Re \approx \frac{L}{\nu} \left(\frac{gQ}{D}\right)^{1/3} \left(\frac{D}{w_c}\right)^{1/3} \quad (65)$$

**12.4.6** The shape coefficient,  $C_s$ , is given by Formulae (66) and (67), both of which can be derived from Formulae (10) and (25), the relationship including throat area in Formula (11) and the geometrical properties of part-circular sections.

For flows within the throat semi-cylinder:

$$C_s = 3^{3/2} \sin \theta_e \left( \frac{\theta_e - \sin \theta_e \cos \theta_e}{4 \sin \theta_e - 5 \sin \theta_e \cos \theta_e + \theta_e} \right)^{3/2} \quad (66)$$

For flows above the axis of the throat semi-cylinder:

$$C_s = \left( \frac{3}{2} \right)^{3/2} \left( \frac{\frac{d_{ce}}{D_e} + \frac{\pi}{8} - \frac{1}{2}}{\frac{3d_{ce}}{2D_e} + \frac{\pi}{16} - \frac{1}{4}} \right)^{3/2} \quad (67)$$

**12.4.7** The approach to the solution of  $C_s$  adopted in the spreadsheet is to produce a table and graph of  $C_s$  against  $H_e/D_e$ , then to look up (interpolating as necessary) the value of  $C_s$  corresponding to the computed value of  $H_e/D_e$ . Although this relationship varies very slightly with flume geometry and the value of the boundary layer displacement thickness, this variation was disregarded when applying the coefficient method given in the previous edition of this International Standard, as a single graphical relationship was provided for U-throated flumes. [Figure 11](#) of the present edition shows a plot of  $C_s$  versus  $H_e/D_e$  for a typical U-throated flume. The table and graph for the specific flume geometry and boundary layer displacement thickness are presented in the “Shape” and “Shape chart” worksheets of the Flume2.xls spreadsheet (see [Annex D](#)) that accompanies this International Standard.

**12.4.8** The value of  $C_v$  is computed from Formula (30), with  $D_e$  substituted in place of  $b_e$ . The area of the approach channel required for use in Formula (30) is obtained from the geometry of the approach channel at the given water level. In most applications of a U-throated flume, the approach channel is also U-shaped, and this is the assumption of the Flume2.xls spreadsheet. Formula (68) gives the approach flow area,  $A_a$ , with the water level lying within the semi-circular base portion and Formula (69) applies if it lies above that portion:

$$A_a = \frac{D_a^2}{4} (\theta_a - \sin \theta_a \cos \theta_a) \quad \text{for } d_a \leq \frac{D_a}{2} \quad (68)$$

$$A_a = \frac{\pi}{8} D_a^2 + \left( d_a - \frac{D_a}{2} \right) D_a \quad \text{for } d_a \geq \frac{D_a}{2} \quad (69)$$

where

$d_a$  is the depth of water in the approach channel at the gauging section relative to the invert level at that point, that is  $d_a = h + p$ ;

$D_a$  is the approach channel width and invert diameter;

$\theta_a$  is the semi-angle (in radians) subtended at the centre of curvature of the invert of the U-shaped approach channel between the water surface and the vertical.

**12.4.9** In order to apply the coefficient method to determine the discharge,  $Q$ , corresponding to a specific gauged head,  $h$ , an iterative approach is required. This is most conveniently accomplished using the spreadsheet for U-throated flumes presented in Flume2.xls (see [Annex D](#)). The solution scheme adopted for the coefficient method in the spreadsheet is given below and this approach is recommended for manual calculations.

**12.4.10** The following basic geometry and parameters are entered into the input data cells of the spreadsheet:

- $D$  diameter (width) of throat;
- $D_a$  diameter (width) of approach channel at gauging section;
- $p$  height of throat invert above approach channel bed;
- $L$  length of throat;

together with the gauged head,  $h$ , for which discharge is to be computed.

**12.4.11** The spreadsheet also requires the user to choose between

- the simple boundary layer treatment, with a fixed value of the dimensionless boundary layer displacement thickness,  $\delta^*/L$ , and
- the detailed boundary layer treatment.

If the detailed treatment is chosen, an additional input item, the roughness amplitude,  $k_s$ , is required (recommended values are shown in [Table 3](#)).

**12.4.12** Default values of the following parameters are given in the spreadsheet, but may be changed by the user.

- $g$  gravitational acceleration (default value of  $9,807 \text{ ms}^{-2}$ );
- $\nu$  kinematic viscosity of water, required only for the detailed boundary layer treatment (default value of  $1,14 \times 10^{-6} \text{ m}^2\text{s}^{-1}$  for water at  $15 \text{ }^\circ\text{C}$  entered, but other values may be derived from [Table 4](#));
- $\alpha$  kinetic energy coefficient for approach channel (default value 1,05);
- $\delta^*/L$  dimensionless boundary layer displacement thickness for simple boundary layer treatment (default value 0,003);
- $C_v$  value of velocity coefficient to use in the first iteration (default value 1,05).

**12.4.13** The spreadsheet then proceeds with the calculations, using the solution sequence set out below. Successive iteration results are set out in tabular form, with each column containing an individual iteration, so that the user can see that the iterations have successfully converged. The spreadsheet includes five iterations.

Step	Description	Parameter	Formula
1	Approach channel flow depth = $h + p$ (non-iterative)	$d_a$	—
2	Approach channel flow depth relative to semicircle axis (non-iterative)	$d_a - D_a/2$	—
3	Angle (radians) from axis to edge of water surface (non-iterative)	$\sigma_a = \pi/2 - \theta_a$	—
4	Water surface width at gauging section (non-iterative)	$w_a$	—
5	Area of approach channel (non-iterative)	$A_a$	—
6	Relative boundary layer displacement thickness (default value taken for first two iterations)	$\delta^*/L$	—
7	Discharge coefficient	$C_D$	(60)
8	Velocity coefficient (default value for first iteration, then value from previous iteration)	$C_v$	—
9	Throat flow width parameter (calculated in worksheet "Throat" using value of $H_e/D_e$ from previous iteration)	$w_{ce}/D_e$	<a href="#">Figure 12</a>
10	Reynolds number	$Re$	(65)
11	Boundary layer displacement thickness (calculated from Reynolds number and throat length in worksheet "Delta-star")	$\delta^*$	—
12	Effective gauged head	$h_e$	(62)
13	Effective total head	$H_e$	(18)
14	Effective throat diameter (width)	$D_e$	(61)
15	Intermediate parameter (used in step 16 for determination of $C_s$ and in step 9 for determination of $w_{ce}/D_e$ )	$H_e/D_e$	—
16	Shape coefficient (interpolated from value of $H_e/D_e$ in worksheet "Shape")	$C_s$	<a href="#">Figure 11</a>
17	Intermediate parameter (used in step 18)	$C_s D_e h_e/A_a$	—
18	Velocity coefficient (computed from $\alpha$ , $A_a$ , current values of $C_s$ , $D_e$ , $h_e$ and value of $C_v$ at previous iteration)	$C_v$	(30) ( $D_e$ in place of $b_e$ )
19	Discharge	$Q$	(59)

## 12.5 Computation of stage-discharge relationship

**12.5.1** The stage–discharge relationship for a U-throated flume is most conveniently obtained by considering a series of values of the critical depth in the throat. For each depth, all the geometric dimensions at the throat are then adjusted for boundary layer effects by reducing them according to the displacement thicknesses, as shown in [Figure 8](#). Standard hydraulic flow theory is then applied to obtain the critical discharge and effective head, to which is added the displacement thickness to obtain the total head. Finally, this is converted to the gauged head by subtracting the velocity head in the approach channel, this being an iterative calculation.

**12.5.2** The process is explained in more detail below, based on the simple boundary layer treatment, in which the value of  $\delta^*/L$  is fixed. For the detailed boundary layer treatment, the value of  $\delta^*$  depends on the Reynolds number, which is not available at the start of the calculations, so there is an additional element of iteration.

**12.5.3** Select a range of values of  $d_c$ , the critical depth in the throat, and for each value of  $d_c$  proceed as follows:

- Deduct the boundary layer thickness,  $\delta^*$ , to obtain the effective critical depth,  $d_{ce}$ .
- Calculate the effective throat diameter,  $D_e$ , from Formula (61).
- Calculate the effective area from Formula (70) or (71) as applicable.



$$A_{ce} = \frac{D_e^2}{4} (\theta_e - \sin\theta_e \cos\theta_e) \text{ for } d_{ce} \leq \frac{D_e}{2} \quad (70)$$

where  $\theta_e$  is the semi-angle (in radians) subtended at the centre of curvature of the invert of the U-throated flume between the water surface and the vertical at the critical flow section (including boundary layer corrections in solving the geometry).

$$A_e = \frac{\pi}{8} D_e^2 + \left( d_{ce} - \frac{D_e}{2} \right) D_e \text{ for } d_{ce} \geq \frac{D_e}{2} \quad (71)$$

For water levels in the throat below the axis of the semi-cylinder, the value of the angle  $\theta_e$  and the effective throat width,  $w_{ce}$ , are computed from Formulae (72) and (73) respectively. For greater depths,  $w_{ce} = D_e$ .

$$\cos\theta_e = \frac{D - 2d_c}{D - 2\delta^*} = \frac{D_e - 2d_{ce}}{D_e} \quad (72)$$

$$w_{ce} = D_e \sin\theta_e \quad (73)$$

d) Calculate  $Q$  using Formula (28).

e) Calculate  $H_e$  using Formula (27).

**12.5.4** Because the datum for the effective total head,  $H_e$ , is  $\delta^*$  above the flume invert, this is then added back to  $H_e$  to obtain the actual total head,  $H$ .

**12.5.5** The final stage of the process requires the velocity head in the approach channel to be deducted from the total head,  $H$ , to obtain the gauged head,  $h$ , as in

$$h = H - \alpha \frac{\bar{v}_a^2}{2g} \quad (74)$$

where  $\bar{v}_a$  is the mean velocity in the approach channel at the gauging section.

**12.5.6** In applying Formula (74), the cross-sectional area,  $A_a$ , of the approach channel, which is assumed here to be U-shaped, is given by Formula (68) or (69) as appropriate, where the angle  $\theta_a$  for approach depths below the centre of curvature of the semi-cylindrical portion is given by

$$\cos\theta_a = \frac{D_a - 2d_a}{D_a} \quad (75)$$

**12.5.7** Because  $h$  occurs implicitly in the right-hand side of Formula (74), a method of successive approximation is needed to determine  $h$ . In the first iteration,  $h$  is approximated to  $H$  for the purposes of calculating  $A_a$  and thence the mean velocity and velocity head. Formula (74) is then used to obtain the first approximation to  $h$ , which is then used at the start of the second iteration. The iterations proceed until there is a negligible difference between successive approximations for the gauged head,  $h$ . In the spreadsheet, worksheets "Circular2a" to "Circular2e" are used to calculate the approach flow area,  $A_a$ , for successive iterations.

**12.5.8** Having thus worked out pairs of values of  $Q$  and  $h$  for a series of values of  $d_c$ , the rating curve for the flume may be plotted to a suitable scale. Conventionally, rating curves are plotted to linear scales, as adopted in the "Rating chart" worksheet of the spreadsheet for U-throated flumes presented in Flume2.xls (see [Annex D](#)). Alternatively, plotting with logarithmic scales renders the curve closer to a straight line, which may be of assistance when interpolating values from it. Logarithmic plotting may also offer improved sensitivity for low heads and flows.

**12.5.9** The key steps used for the rating calculations in the “Rating” worksheet of the spreadsheet for U-throated flumes presented in Flume2.xls (see [Annex D](#)) are set out below. Successive iteration results are set out in tabular form, with each column containing an individual iteration, so that the user can see that the iterations have successfully converged. The spreadsheet includes five iterations to obtain the gauged head from the total head, but only one iteration for the boundary layer displacement thickness when using the detailed boundary treatment.

Step	Description	Parameter	Formula
(a)	Effective throat diameter (width)	$D_e$	(61)
(b)	Minimum critical depth in throat taken as 0,03m	$d_c(\text{min.})$	—
(c)	Estimated maximum permissible critical depth in throat, increased by 5 %	$d_c(\text{max.})$	—
(d)	Range of critical depths divided into a series of 50 increments below the flume axis ( $d_c = D/2$ ) and 50 above the axis	—	—
(e)	The 101 values of critical depth are listed in a column at the left side of the worksheet	$d_c$	—
(f)	Boundary layer displacement thickness (based on the simple theory) is deducted from $d_c$ to obtain the effective value	$d_{ce}$	—
(g)	Effective surface width (from “Circular1” worksheet)	$w_{ce}$	(73) or $D_e$
(h)	Effective flow area (from “Circular1” worksheet)	$A_{ce}$	(70) or (71)
(i)	Critical flow in throat	$Q$	(28)
(j)	Reynolds number	$Re$	(65)
(k)	Boundary layer displacement thickness (calculated from Reynolds number and throat length in worksheet “Delta-star”)	$\delta^*$	—
(l)	Steps (a) and (f) to (i) are repeated using the value of $\delta^*$ obtained in step (k)	$D_e, d_{ce}, w_{ce}, A_{ce}, Q$	See above
(m)	Critical flow velocity in throat = $Q/A_{ce}$	$v_{ce}$	—
(n)	Effective total head	$H_e$	(27)
(o)	Total head = $H_e + \delta^*$	$H$	—
(p)	Gauged head (iterative calculation as described in <a href="#">12.5.7</a> )	$h$	(74)
(q)	Froude number in approach channel (for information)	$Fr$	(76)

## 12.6 Limits of application

**12.6.1** The practical lower limit of  $h$  is related to the magnitude of the influence of fluid properties and boundary roughness. The recommended lower limit of 0,05 m or 0,05 $L$ , whichever is the greater.

**12.6.2** There is also a limit on the ratio of the areas of the approach channel and the throat arising from difficulties experienced when the Froude number in the approach channel exceeds about 0,5. This shall be checked at each end of the range, and at intermediate flows, using Formula (76). The “Rating” worksheet in the spreadsheet for U-throated flumes presented in Flume2.xls (see [Annex D](#)) tabulates values of the Froude number, and selected values are also included in the “Summary” worksheet.

$$Fr_a = \bar{v}_a \sqrt{\frac{\alpha w_a}{g A_a}} = Q \sqrt{\frac{\alpha w_a}{g A_a^3}} \leq 0,5 \quad (76)$$

**12.6.3** It may be necessary in some situations (for example where coarse sediment is being carried which would deposit in the approach channel) to allow  $Fr_a$  to rise to 0,6 but, because of surface irregularities at high Froude numbers, the measurement of head and performance of the flume are less certain, and an additional uncertainty in coefficient of 2 % over that derived by Formula (77) should be allowed when  $0,6 > Fr_a > 0,5$ .

**12.6.4** Other limitations are as follows.

- a)  $D$  shall be at least 0,1 m.
- b) The ratio  $h/L$  should not exceed 0,50.
- c) At all elevations, the width between the throat walls shall be less than the width between the approach channel walls at the same elevation, i.e. there shall be a contraction wherever the water surface lies.

**12.6.5** The above limitation on  $h/L$  arises from the necessity to ensure parallel flow conditions at the critical section in the throat. However, the ratio  $h_{\max}/L$  may be allowed to rise to 0,67, with an additional uncertainty in coefficient of 2 % over that derived by Formula (77).

**12.6.6** The previous edition of this International Standard (ISO 4359:1983) required that the gauged head,  $h$ , be not more than 2 m. However, there is no technical justification for this restriction, so it does not apply in the present edition.

**12.6.7** The overall uncertainty of measurement, due to experimentally determined coefficients, the tolerances in the construction of the flume referred to in 6.2.2 and the difficulties in making accurate upstream head measurements, is described in detail in [Clauses 13](#) and [14](#).

**12.6.8** With reasonable skill and care in the construction of the flume, the coefficients are expected to have an uncertainty approaching 1 % in favourable circumstances, for example when  $C_D$  and  $C_v$  are not far from unity. An estimate of the standard percentage uncertainty of the discharge coefficient,  $u^*(C)$ , may be obtained from

$$u^*(C) = \pm [1 + 20(C_v - C_D)]\% \quad (77)$$

## 13 Uncertainties of flow measurement

### 13.1 General

**13.1.1** This clause provides information for estimating and stating the uncertainty of a measurement of discharge. The overall uncertainty of measurement depends on

- a) the standard of construction and finish of the flume,
- b) the uncertainty of the formula for the coefficient of discharge,
- c) the uncertainty in the value for kinetic energy coefficient,  $\alpha$ , which is required to determine the total head upstream using the velocity of approach,
- d) the correct application of the installation conditions,
- e) the uncertainty of the zero setting,
- f) the uncertainty of measurement of the geometry of the flume, and
- g) the accuracy of the upstream head gauge.

**13.1.2** [Annex B](#) presents an introduction to measurement uncertainty, providing supporting information based on ISO/IEC Guide 98-3<sup>[6]</sup> and ISO 5168<sup>[3]</sup>.

**13.1.3** A comprehensive measurement result comprises

- a) an estimate of the measured value, and

b) a statement of the uncertainty of the measurement.

**13.1.4** A statement of the uncertainty of a flow measurement in a channel has at least seven components of uncertainty, grouped together here in three broad categories, dealing with inaccuracies in measurement, uncertainties in the flume dimensions and uncertainties in the values that should be assigned to the various hydraulic coefficients:

- a) uncertainty of the measurement of head in the channel,  $h$ ;
- b) uncertainty of the dimensions of the structure,  $b$ ,  $D$  or  $m$ ;
- c) uncertainty of the discharge coefficients,  $C_D$ ,  $C_S$  and  $C_v$ .

**13.1.5** The estimation of measurement uncertainty associated with items a) and b) of 13.1.4 is taken from Annex C. These values are for illustrative purposes only; they should not be interpreted as norms of performance for the types of equipment listed. Item c) is assessed using the approach set out in 13.2.2. In practice, uncertainty estimates should be taken from test certificates for the equipment, preferably obtained from a laboratory with accreditation to ISO/IEC 17025.

## 13.2 Combining measurement uncertainties

**13.2.1** See Annex B for an introduction to measurement uncertainty. The proportion in which each flow equation parameter contributes to flow measurement uncertainty,  $U(Q)$ , is derived by analytical solution using partial differentials of the discharge equation.

**13.2.2** A form of the discharge equation, similar to Formulae (19), (23) and (25), for critical depth flumes, but with the exponent also made a variable,  $\varphi$ , and not fixed at 1,50, as previously assumed, is represented by

$$Q = \left(\frac{2}{3}\right)^{3/2} C_D C_v C_s g^{1/2} b h^\varphi \quad (78)$$

**13.2.3** Errors in  $g$ , the acceleration due to gravity, may be ignored. For U-throated flumes the diameter of the base,  $D$ , is substituted for  $b$  and  $C_s$  is retained, but has a formulation distinct from that for a trapezoidal flume. For trapezoidal flumes additional account is made for uncertainty in the sideslope,  $m$ .

**13.2.4** The effect on the value  $Q$  due to small dispersions of  $\Delta C$ ,  $\Delta b$ ,  $\Delta h$  and  $\Delta m$  is

$$\Delta Q = \frac{\partial Q}{\partial C} \Delta C + \frac{\partial Q}{\partial b} \Delta b + \frac{\partial Q}{\partial h} \Delta h + \frac{\partial Q}{\partial m} \Delta m \quad (79)$$

The partial derivatives are the sensitivity coefficients that relate to the discharge equation, and  $\Delta Q$  is the resultant dispersion of  $Q$ . Evaluating the partial differentials the relationship can be written as

$$\frac{\Delta Q}{Q} = \frac{\Delta C}{C} + \gamma \cdot \frac{\Delta b}{b} + \varphi \cdot \frac{\Delta h}{h} + \psi \cdot \frac{\Delta m}{m} \quad (80)$$

where  $\gamma$ ,  $\varphi$ , and  $\psi$  are the relative sensitivity coefficients which depend on the flume geometry:

$$\frac{\delta Q}{\delta C} = 1, \quad \frac{\delta Q}{\delta b} = \gamma, \quad \frac{\delta Q}{\delta h} = \varphi, \quad \frac{\delta Q}{\delta m} = \psi$$

**13.2.5** The values  $\Delta Q/Q$ ,  $\Delta C/C$ ,  $\Delta b/b$ ,  $\Delta h/h$  and  $\Delta m/m$  are referred to as dimensionless standard uncertainties and are given the notation  $u^*(Q)$ ,  $u^*(C)$ ,  $u^*(b)$ ,  $u^*(h)$ , and  $u^*(m)$ . Since the uncertainties of  $b$ ,  $C$ ,  $h$  and  $m$  are likely to be independent of each other, probability requires that the components to be summated in quadrature (see B 7).

$$u_c^*(Q)_{68} \cong \sqrt{u^*(C)^2 + \gamma^2 \cdot u^*(b)^2 + \varphi^2 \cdot u^*(h)^2 + \psi^2 \cdot u^*(m)^2} \quad (81)$$

**13.2.6** In the straightforward case of a rectangular-throated flume,  $\gamma = 1$ ,  $\varphi = 1,5$ , and  $\psi = 0$  (assuming the walls are truly vertical).

**13.2.7** For a trapezoidal-throated flume,  $\gamma$  and  $\psi$  depend on  $mH_{ce}/b$ , as shown in [Figure 13](#). For practical purposes the approximation  $H_{ce} \approx H \approx h$  is sufficiently accurate for use in these curves. These coefficients can be determined numerically using the following relationships:

$$\gamma = \frac{3}{3 + \frac{2mH_{ce}}{b}} \quad (82)$$

$$\varphi = \frac{\frac{10mH_{ce}}{b} + 9}{2 \left( 3 + \frac{2mH_{ce}}{b} \right)} \quad (83)$$

$$\psi = \frac{\frac{2mH_{ce}}{b}}{3 + \frac{2mH_{ce}}{b}} \quad (84)$$

**13.2.8** For a U-throated flume  $\psi = 0$  (assuming the walls are truly vertical),  $\gamma$  and  $\varphi$  depend on  $H_{ce}/D$  and are shown in [Figure 13](#). For practical purposes the approximation  $H_{ce} \approx H \approx h$  is sufficiently accurate for use in these curves. These coefficients can be determined numerically using the following relationships for flow depths within the semi-cylindrical throat only:

$$\gamma = \left[ 2^{2/3} + \frac{1}{\sqrt{3}} \left( \frac{H_{ce}}{D} \right)^{-\sqrt{3}} \right]^{-\sqrt{3}} + 0,54 \quad (85)$$

$$\varphi = \left[ 4,8 + 25 \left( \frac{H_{ce}}{D} \right)^{5/2} \right]^{-1/2} + \frac{3}{2} \quad (86)$$

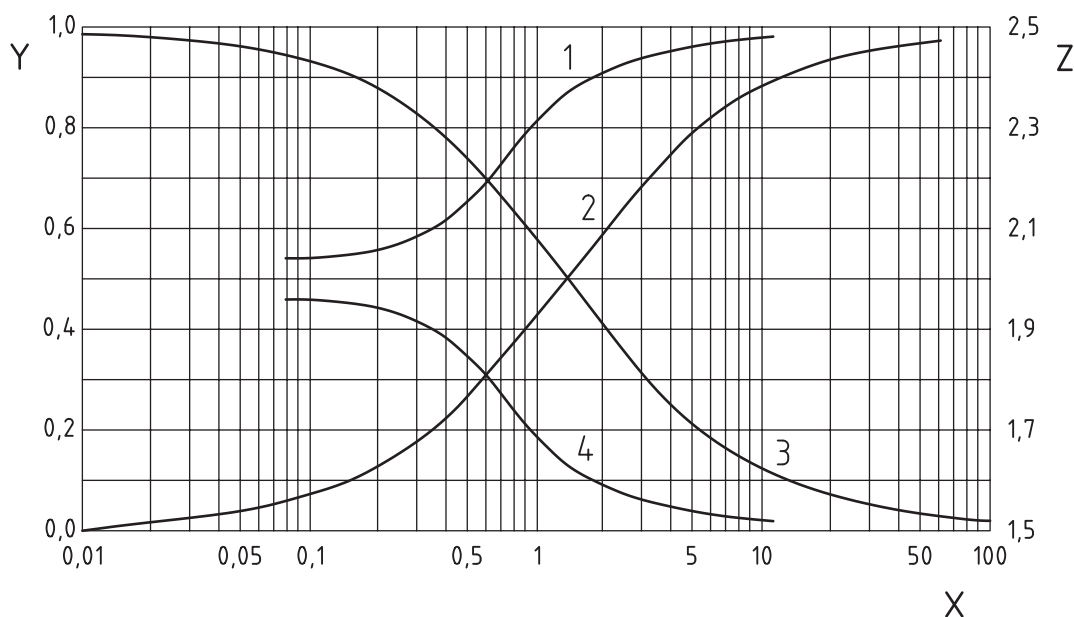

**Key**

- X trapezoidal,  $mH_{ce}/b$ ; U shaped  $H_{ce}/D$
- Y  $\psi$  and  $\gamma$
- Z  $\varphi$
- 1  $\gamma$  (U-shaped)
- 2  $\psi$  and  $\varphi$  (trapezoidal)
- 3  $\gamma$  (trapezoidal)
- 4  $\varphi$  (U shaped)

**Figure 13 — Accuracy coefficients**

**13.3 Percentage uncertainty of discharge coefficient  $u^*(C)$  for critical-depth flumes**

Coefficients  $C_D$  and  $C_V$  are assumed to be covered by the combined percentage uncertainty  $u^*(C)$ . For trapezoidal flumes  $C_S$  is dependent upon knowledge of the sideslope,  $m$ ; additional allowance is made in the uncertainty budget by estimating and including the uncertainty in  $m$ . With reasonable skill and care in the construction of the flume, the coefficients are expected to have an uncertainty approaching 1 % in favourable circumstances, for example when  $C_D$  and  $C_V$  are not far from unity. An estimate of the standard percentage uncertainty of the discharge coefficient  $u^*(C)$  may be obtained from

$$u^*(C) = \pm [1 + 20(C_V - C_D)]\% \tag{87}$$

NOTE The previous edition of this International Standard expressed the uncertainty of discharge coefficient  $u^*(C)$  at the 95 % level of confidence. This version expresses discharge coefficient as standard uncertainty at around 68 % level of confidence. This is in accordance with ISO/IEC Guide 98-3.[6] See [Annex B](#) for the definitions.

**13.4 Uncertainty budget**

**13.4.1** In reports, an uncertainty budget table may be presented (or referenced) to provide the following information for each source of uncertainty:

- a) the method of evaluation (from [Annex B](#));
- b) the determined value of relative standard uncertainty  $u^*(C)$ ,  $u^*(b)$ ,  $u^*(m)$  and  $u^*(h)$ , including datum uncertainty of  $u^*(h)$ ;

c) the relative sensitivity coefficients.

**13.4.2** Apply the values for each source according to Formula (81) to give the combined standard uncertainty,  $U_c^*(Q)_{68}$ . A coverage factor  $k = 2$  shall then be applied to define the uncertainty at the 95 % level of confidence. It is customary to present these steps in tabular form with one row for each source and a column for each of the items a) to c) above. The table may include, where appropriate, the critical thinking behind the subjective allocation of uncertainty to the quantities  $b$ ,  $m$ , and  $h$  and their sub-components. This section of the table may be replicated for a range of values of  $h$  to determine a relationship between  $U^*(Q)$  and  $h$ .

## 14 Example of uncertainty calculations

### 14.1 General

**14.1.1** In presenting examples, the equations given in [Clause 13](#) define the relationship between the parameters which determine flow rate.

**14.1.2** Uncertainty of the discharge coefficient is a fundamental uncertainty and is defined by Formula (87). To determine the overall uncertainty of flow measurement, practical estimations shall be made of the head measurement uncertainty and the uncertainty of the measurement of physical dimensions. [Annex B](#) provides a consistent framework for evaluating these uncertainties for the commonly used measurement techniques.

### 14.2 Characteristics — Gauging structure

The example relates to modular flow conditions for a rectangular-throated, critical-depth flume with a gauged head,  $h$ , of 0,3 m; a throat width,  $b$ , of 0,2 m; an approach channel width,  $B$ , of 0,5 m; a hump height,  $p$ , of zero and a throat length,  $L$ , of 1,2 m. The calculations are based on simple boundary layer theory.

### 14.3 Characteristics — Discharge calculation

The flow rate is calculated from Formula (34):

$$Q = \left(\frac{2}{3}\right)^{3/2} g^{1/2} C_D C_v b h^{3/2}$$

in which the coefficient of discharge,  $C_D$ , is derived using Formula (39):

$$C_D = \left(1 - 0,006 \frac{L}{b}\right) \left(1 - 0,003 \frac{L}{h}\right)^{3/2}$$

and  $C_v$  is computed from Formulae (30), (31), (36) and (37). It is established that  $C_D = 0,947$  and  $C_v = 1,035$ . Applying these values to Formula (34):

$$Q = \left(\frac{2}{3}\right)^{3/2} 9,807^{1/2} \times 0,947 \times 1,035 \times 0,2 \times 0,3^{3/2} = 0,0549 \text{ m}^3/\text{s}$$

### 14.4 Characteristics — Discharge coefficient

The percentage uncertainty in the discharge coefficient is established from Formula (91) and is assumed to be a “Type B” with a Gaussian (normal) distribution; in [14.3](#) it was determined that  $C_D = 0,947$  and  $C_v = 1,035$ . Applying these values to Formula (91):

$$u^*(C) = \pm [1 + 20(1,035 - 0,947)] = \pm 2,76 \%$$

## 14.5 Characteristics — Gauged head instrumentation

**14.5.1** In this example, an air range ultrasonic sensor is used to determine head. The sensor is fixed at an elevation of 0,650 m above the hydraulic datum. The datum procedure determines that the elevation is between 0,651 m and 0,649 m. Referring to B.6.1, the relative datum uncertainty,  $u(E)$ , assuming a triangular probability distribution is given by

$$u(E) = \frac{1}{\sqrt{6}} \left( \frac{\text{max. value} - \text{min. value}}{2} \right) = \frac{1}{\sqrt{6}} \left( \frac{0,651 - 0,649}{2} \right) = 0,0004 \text{ m}$$

**14.5.2** The sonic range from the sensor to the measured water surface is the primary measurement of the sensor. The measured distance is 0,350 m. The resultant gauged head measurement is confirmed at  $h = 0,300$  m. The uncertainty of head measurement, as stated by the manufacturer as a percentage of the range,  $u(R)$ , is 1 %. This equates to 0,0035 m. The combined head measurement uncertainty is therefore:

$$u(h) = \sqrt{u(E)^2 + u(R)^2} = \sqrt{0,0004^2 + 0,0035^2} = 0,00352 \text{ m}$$

or expressed as a percentage of  $h = 0,300$  m:

$$u^*(h) = \frac{u(h)}{h} = \frac{0,00352}{0,300} = 1,17 \% \quad (88)$$

**14.5.3** If the flume datum is liable to accumulate algal or other growth, the uncertainty value of head measurement shall be increased accordingly.

## 14.6 Characteristics — Throat width

**14.6.1** Dimensional uncertainties depend upon the accuracy to which the flume, as constructed, can be measured. Neither the methods of measurements nor the way in which they were made are specified. Instead, the user shall estimate any additional uncertainties arising and include these in the uncertainty budget. This example assumes that measurements can be practically determined with a resolution to no better than 2 mm or  $\pm 1$  mm.

**14.6.2** The combined uncertainty in throat width,  $u(b)$ , in this example, is given by the following relationship:

$$u(b) = \sqrt{u(b_r)^2 + u(b_m)^2}$$

**14.6.3** Without more information on the dispersion it shall be assumed that the probability distribution in acquiring the throat width data,  $u(b_r)$ , is rectangular. From Formula B.5, the value of uncertainty of the throat width of the critical depth flume may be written as

$$u(b_r) = \frac{1}{\sqrt{3}} \left( \frac{\text{max. width} - \text{min. width}}{2} \right) = \frac{1}{\sqrt{3}} \left( \frac{0,002}{2} \right) = 0,00058 \text{ m}$$

**14.6.4** Also, the value of uncertainty of the throat width of the critical depth flume,  $u(b_m)$ , is assumed as a rectangular distribution:

$$u(b_m) = \frac{1}{\sqrt{3}} \left( \frac{\text{max. width} - \text{min. width}}{2} \right) = \frac{1}{\sqrt{3}} \left( \frac{0,201 - 0,198}{2} \right) = 0,00087 \text{ m}$$

**14.6.5** The combined uncertainty in throat width is therefore:



$$u(b) = \sqrt{u(b_r)^2 + u(b_m)^2} = \sqrt{0,00058^2 + 0,00087^2} = 0,00104 \text{ m}$$

Or is expressed as a percentage of  $b = 0,200 \text{ m}$ :

$$u^*(b) = \frac{u(b)}{b} = \frac{0,00104}{0,200} = 0,52\% \quad (89)$$

## 14.7 Overall uncertainty in discharge

**14.7.1** The combined uncertainty value is determined from Formula (81), in [13.2.5](#).

**14.7.2** In the simple case of a rectangular flume and assuming the walls are truly vertical:  $\gamma = 1$ ,  $\varphi = 1,5$  and  $\psi = 0$ , hence:

$$u_c^*(Q)_{68} = \sqrt{2,76^2 + 0,52^2 + (1,5 \times 1,17)^2} = 3,3\% \quad (90)$$

**14.7.3** The uncertainty at the 95 % confidence level is therefore given by

$$U_c^*(Q)_{95} = 2 \times u_c^*(Q)_{68} = 6,6\% \quad (91)$$

**14.7.4** The statement of discharge is therefore

- a flow rate of  $0,0549 \text{ m}^3/\text{s}$ , with
- an uncertainty of  $6,6\%$  at the  $95\%$  level of confidence.

**14.7.5** An uncertainty budget for the example is given in [Table 5](#).

**Table 5 — Uncertainty budget for example of flow in a rectangular-throated flume**

Parameter	Type/evaluation	$u$ and $u^*$ values	Sensitivity coefficients	Comment
$u^*(C)$	B/Normal	2,76 %	1,0	From <a href="#">13.2.2</a>
$u(E)$	B/Triangular	0,000 4 m	—	From <a href="#">Table B.1</a>
$u(R)$	B/Manufacturer	1,0 % of range	—	From <a href="#">Table B.1</a>
$u^*(h)$	Combined	1,17 %	1,5	Using Formula (88)
$u(b_r)$	B/Rectangular	0,002 m	—	Assumed resolution
$u(b_m)$	B/Rectangular	0,000 87	—	Measured range
$u^*(b)$	Combined	0,52 %	1,0	Using Formula (89)
$u^*(Q)_{68}$	Combined	3,3 %	—	Using Formula (90)
$u^*(Q)_{95}$	Combined	6,6 %	—	Using Formula (91)

## Annex A (informative)

### Simplified head-discharge relationships for flume

The curves presented in [Figures A.1 to A.8](#) are intended to aid in the selection of an appropriate type and size of flume to suit a particular discharge range. They are based on a fixed discharge coefficient of  $C_D = 0,97$  and the head given is the total upstream head (including the approach velocity head) rather than the gauged head.

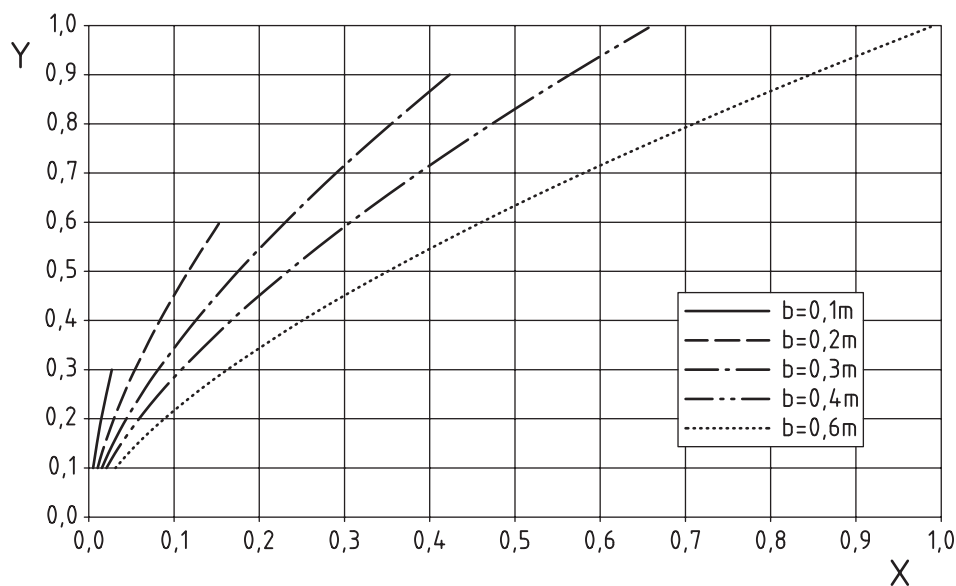

**Key**

X discharge, m<sup>3</sup>/s

Y head, m

**Figure A.1 — Rectangular flumes — Small**

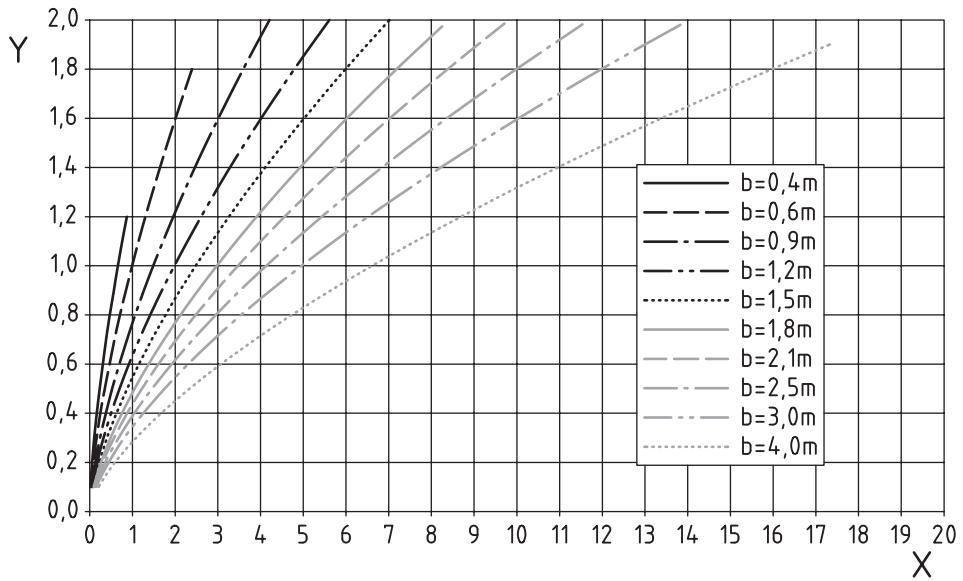

**Key**  
 X discharge, m<sup>3</sup>/s  
 Y head, m

**Figure A.2 — Rectangular flumes — Large**

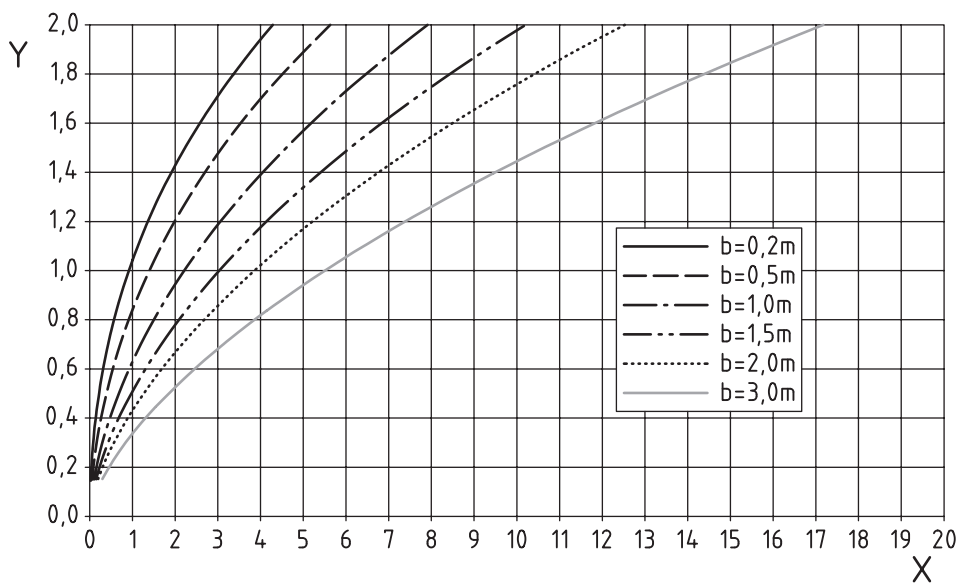

**Key**  
 X discharge, m<sup>3</sup>/s  
 Y head, m

**Figure A.3 — Trapezoidal: sideslope  $m = 0,5$**

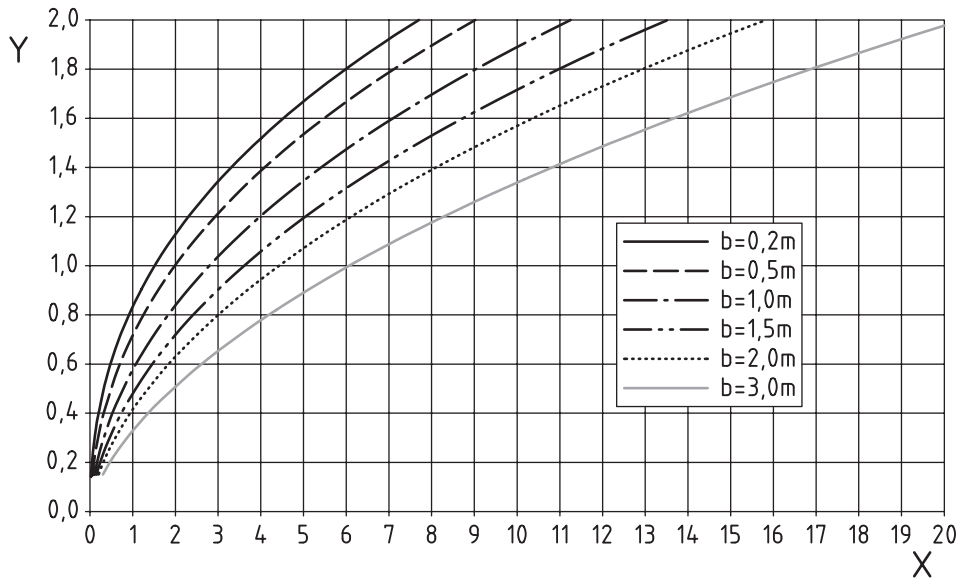

**Key**  
 X discharge, m<sup>3</sup>/s  
 Y head, m

**Figure A.4 — Trapezoidal: sideslope  $m = 1$**

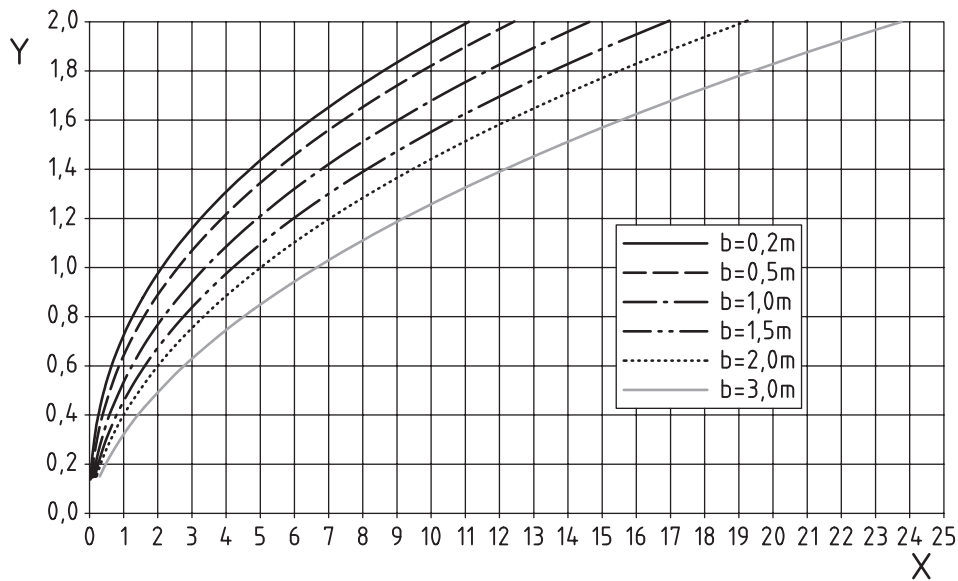

**Key**  
 X discharge, m<sup>3</sup>/s  
 Y head, m

**Figure A.5 — Trapezoidal: sideslope  $m = 1,5$**

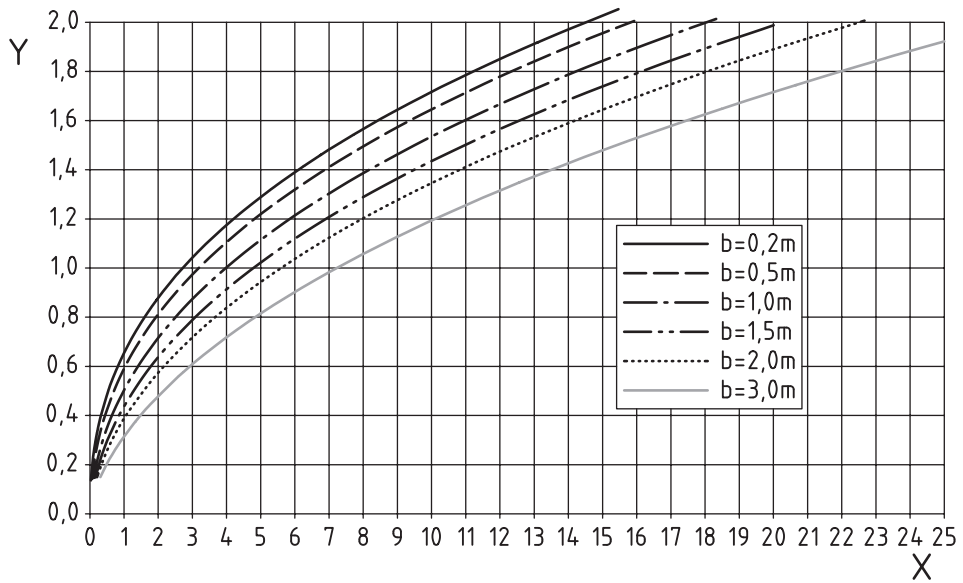

**Key**

X discharge, m<sup>3</sup>/s  
 Y head, m

**Figure A.6 — Trapezoidal: sideslope  $m = 2$**

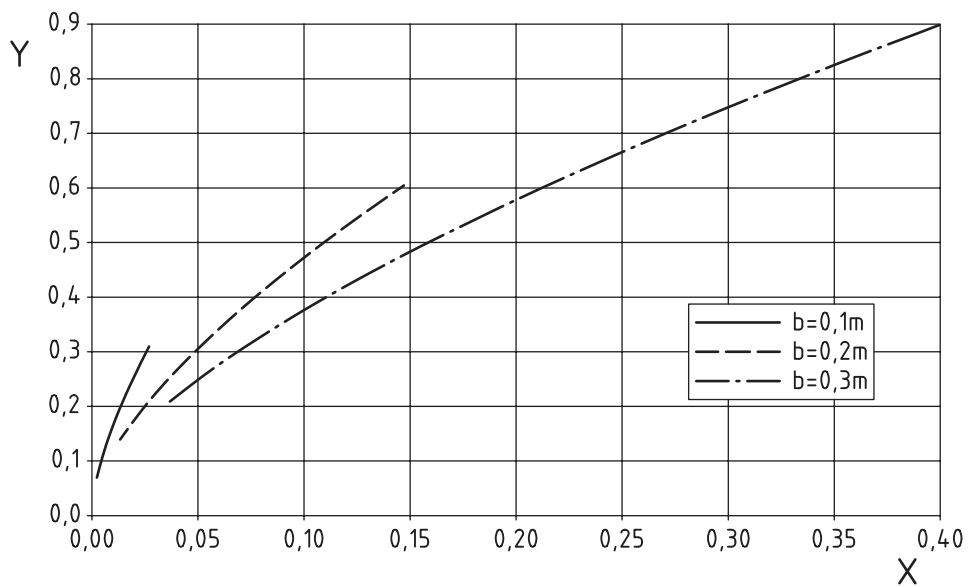

**Key**

X discharge, m<sup>3</sup>/s  
 Y head, m

**Figure A.7 — U-throated flumes — Small**

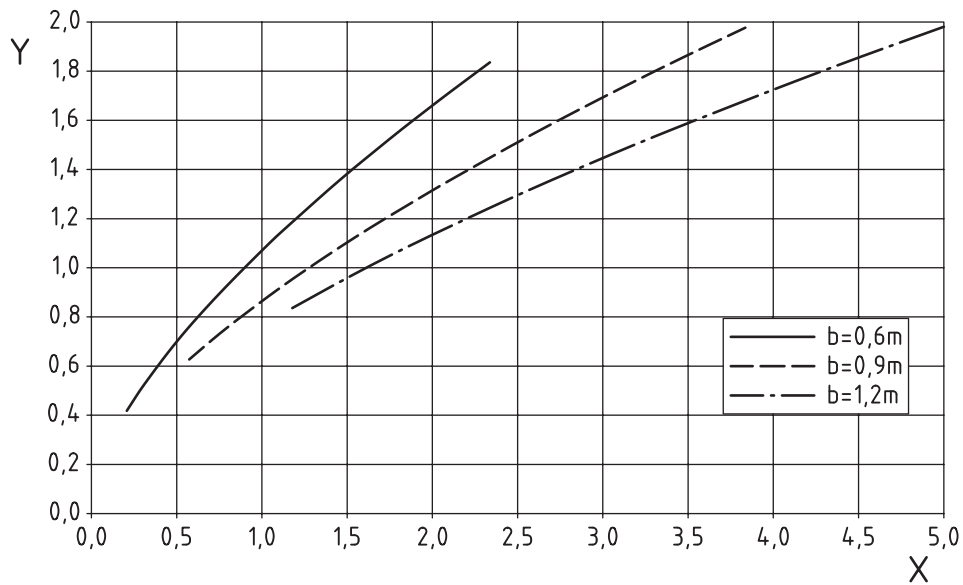

**Key**

X discharge, m<sup>3</sup>/s

Y head, m

**Figure A.8 — U-throated flumes — Large**

## Annex B (informative)

### Introduction to measurement uncertainty

#### B.1 General

Results of measurements or analysis cannot be exact. The discrepancy between the true value — which is unknowable — and the measured value is the measurement error. The concept of uncertainty is a way of expressing this lack of knowledge. For example, if water is controlled to flow at a constant rate, then a flow meter will exhibit a spread of measurements about a mean value. If attention is not given to the uncertain nature of data, incorrect decisions can be made which may have financial or judicial consequences. A realistic statement of uncertainty enhances the information, making it more useful.

The uncertainty of a measurement represents a dispersion of values that could be attributed to it. Statistical methods provide objective values based on the application of theory. Standard uncertainty is defined as

“Standard uncertainty equates to a dispersion of measurements expressed as a standard deviation.”

From this definition, uncertainty can be readily calculated for a set of measurements.

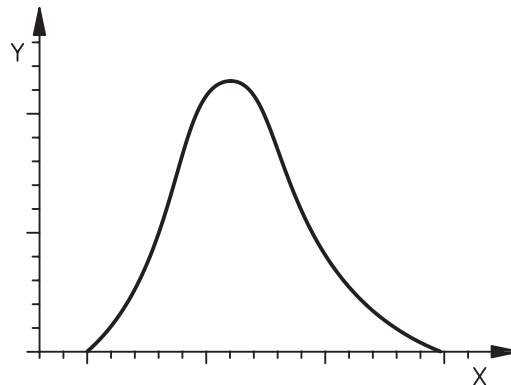

a)

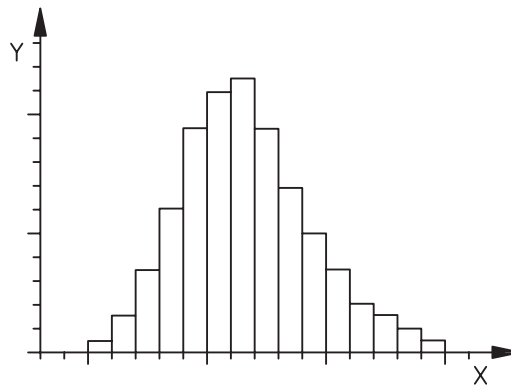

b)

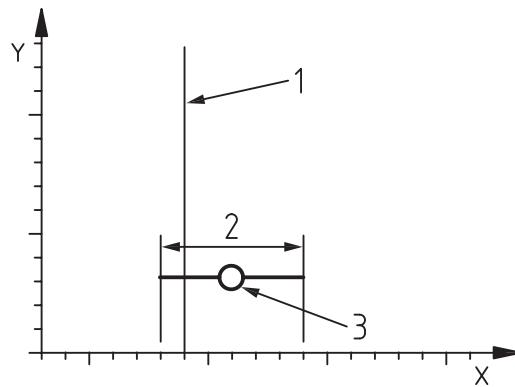

c)

**Key**

- X flow value
- Y a) probability; b) number of samples
- 1 limit
- 2 standard deviation
- 3 mean value

**Figure B.1 — Pictorial representation of some uncertainty parameters**

[Figure B.1 a\)](#) shows the probability that a measurement of flow *under steady conditions* takes a particular value due to the uncertainties of various components of the measurement process, in the form of a probability density function.

[Figure B.1 b\)](#) shows sampled flow measurements, in the form of a histogram.

[Figure B.1 c\)](#) shows standard deviation of the sampled measurements compared with a limiting value. The mean value is shown to exceed the limiting value, but is within the band of uncertainty (expressed as the standard deviation about the mean value).

## B.2 Confidence limits and coverage factors

For a normal probability distribution, analysis shows that 68 % of a large set of measurements lie within one standard deviation of the mean value. Thus standard uncertainty is said to have a 68 % level of confidence.

However, for some measurement results it is customary to express the uncertainty at a level of confidence which will cover a larger portion of the measurements, for example at a 95 % level of confidence (see [Figure B.4](#)). This is done by applying a factor known as the coverage factor,  $k$ , to the computed value of standard uncertainty.

For a normal probability distribution, 95,45 % (effectively 95 %) of the measurements are covered for a value of  $k = 2$ . Thus, uncertainty at the 95 % level of confidence is twice the standard uncertainty value.

In practice, measurement variances rarely follow closely the normal probability distribution. They may be better represented by triangular, rectangular or bimodal probability distributions and only sometimes approximate to the normal distribution. So, a probability distribution must be selected to model the observed variances. To express the uncertainty of such models at the 95 % confidence limit requires a coverage factor that represents 95 % of the observations. However, the same coverage factor,  $k = 2$ , is used for all models. This simplifies the procedure while ensuring consistency of application within tolerable limits.



### B.3 Random and systematic error

The terms *random* and *systematic* have been applied in hydrometric standards to distinguish between

- random errors, which represent an inherent dispersion of values under steady conditions, and
- systematic errors, which are associated with inherent limitations of the means of determining the measured quantity.

A difficulty with the concept of systematic error is that systematic error cannot be determined without pre-knowledge of true values. If its existence is known or suspected, then steps shall be taken to minimize such error, either by recalibration of equipment or by reversing its effect in the calculation procedure — at which point, systematic error contributes to uncertainty in the same way as random components of uncertainty.

For this reason, ISO/IEC Guide 98-3<sup>[6]</sup> does not distinguish between the treatment of random and systematic uncertainties. Generally when determining a single discharge, random errors dominate and there is no need to separate random and systematic errors. However, where (say) totalised volume is established over a long time base, the systematic errors, even when reduced, can remain dominant in the estimation of uncertainty.

### B.4 Measurement standards

ISO/IEC Guide 98-3<sup>[6]</sup> and ISO 5168<sup>[3]</sup> provide rules for the application of the principles of measurement uncertainty: in particular on the identification of components of error, the quantification of their corresponding uncertainties and how these are combined using methods derived from statistical theory into an overall result for the measurement process.

The components of uncertainty are characterized by estimates of standard deviations. There are two methods of estimation:

#### **Type-A estimation**

By statistical analysis of repeated measurements from which an equivalent standard deviation is derived. This process may be automated in real time for depth or for velocity measurement.

#### **Type-B estimation**

By ascribing a probability distribution to the measurement process. This is applicable to

- human judgement of a manual measurement (distance or weight),
- manual readings taken from instrumentation (manufacturer's statement), or
- calibration data (from manufacturer).

## B.5 Evaluation of Type-A uncertainty

Defined in B.1, *standard uncertainty* equates to a dispersion of measurements expressed as a standard deviation. Thus, any single measurement of a set of  $n$  measurements has by definition an uncertainty:

$$u(x) = t_c \sqrt{\frac{1}{n-1} \sum_{i=1}^n (x - \bar{x})^2} \quad (\text{B.1})$$

where,  $\bar{x}$ , the “best estimate”, is the mean value:

$$\bar{x} = \frac{1}{n} (x_1 + x_2 + \dots + x_n) \quad (\text{B.2})$$

and  $t_c$  is a factor derived from statistical theory to account for the increased uncertainty when small numbers of measurements are available (see [Table B.1](#)).

If, instead of a single measurement from the set, the uncertainty is to apply to the mean of all  $n$  values, then:

$$u(\bar{x}) = \frac{t_c}{\sqrt{n}} \sqrt{\frac{1}{n-1} \sum_{i=1}^n (x - \bar{x})^2} \quad (\text{B.3})$$

For continuous measurement, Type-A evaluations may be derived as a continuous variable from the primary measurement: i.e. from water level or water velocity.

By taking average values over large numbers,  $n$ , of measurements, the uncertainty of the mean value  $u(\bar{x})$  is reduced by a factor of  $\frac{1}{\sqrt{n}}$  compared to the uncertainty  $u(x)$  of an individual measurement. For this reason, monitoring equipment should specify measurement performance in terms including both  $u(\bar{x})$  and  $u(x)$  to show the extent to which averaging is applied.

**Table B.1 — Values of  $t_c$**

Degree of freedom	Confidence level %		
	90	95	99
1	6,31	12,71	63,66
2	2,92	4,30	9,92
3	2,35	3,18	5,84
4	2,13	2,78	4,60
5	2,02	2,57	4,03
10	1,81	2,23	3,17
15	1,75	2,13	2,95
20	1,72	2,09	2,85
25	1,71	2,06	2,79
30	1,70	2,04	2,75
40	1,68	2,02	2,70
60	1,67	2,00	2,66
100	1,66	1,98	2,63
Infinite	1,64	1,96	2,58

## B.6 Evaluation of Type-B uncertainty

### B.6.1 General

When there is no access to a continuous stream of measured data or a large set of measurements is not available, then the type-B method of estimation is used to

- a) assign a probability distribution to the measurement process to represent the probability of the true value being represented by any single measured value,
- b) define upper and lower bounds of the measurement, and,
- c) then determine a standard uncertainty from a standard deviation implied by the assigned probability distribution.

The Type-B methods allow estimates of upper and lower bounding values to be used to derive the equivalent standard deviation.

Four probability distributions are described in ISO/IEC Guide 98-3[6] and these are described in B.6.2 to B.6.5.

### B.6.2 The triangular distribution

The triangular distribution is represented in Formula (B.4) and [Figure B.2](#). This usually applies to manual measurements where the mean value is most likely to be closer to the true value than others between the discernible upper and lower limits of the measurement.

$$u(x_{\text{mean}}) = \frac{1}{\sqrt{6}} \left( \frac{x_{\text{max}} - x_{\text{min}}}{2} \right) \quad (\text{B.4})$$

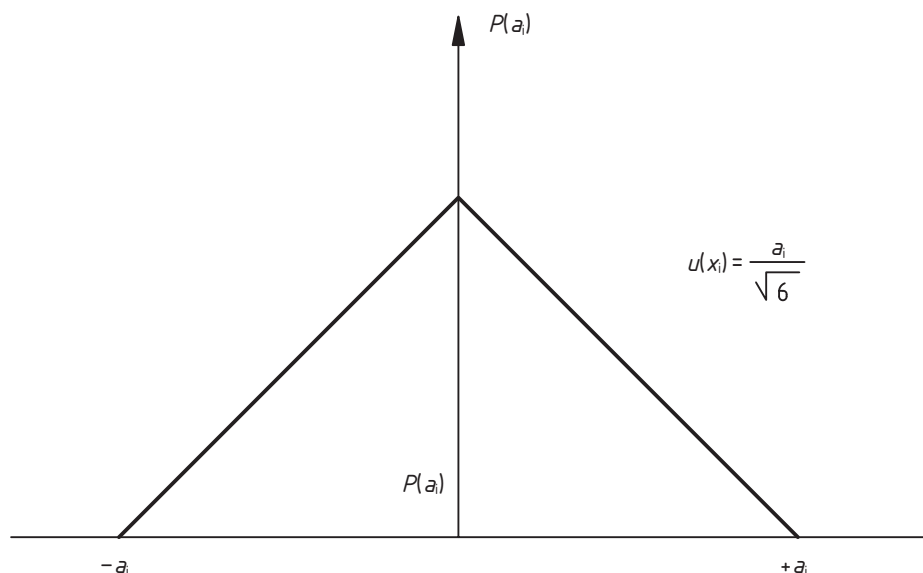

Figure B.2 — The triangular distribution

### B.6.3 The rectangular distribution

The rectangular distribution is represented in Formula (B.5) and [Figure B.3](#). This probability distribution is usually applied to the resolution limit of the measurement instrumentation (i.e. the displayed resolution or the resolution of internal analogue/digital converters). However, this is not the only source of uncertainty of measurement equipment. There may be uncertainty arising from the measurement

algorithm used and/or from the calibration process. If the equipment measures relative values, then there will also be uncertainty in the determination of its datum.

$$u(x_{\text{mean}}) = \frac{1}{\sqrt{3}} \left( \frac{x_{\text{max}} - x_{\text{min}}}{2} \right) \quad (\text{B.5})$$

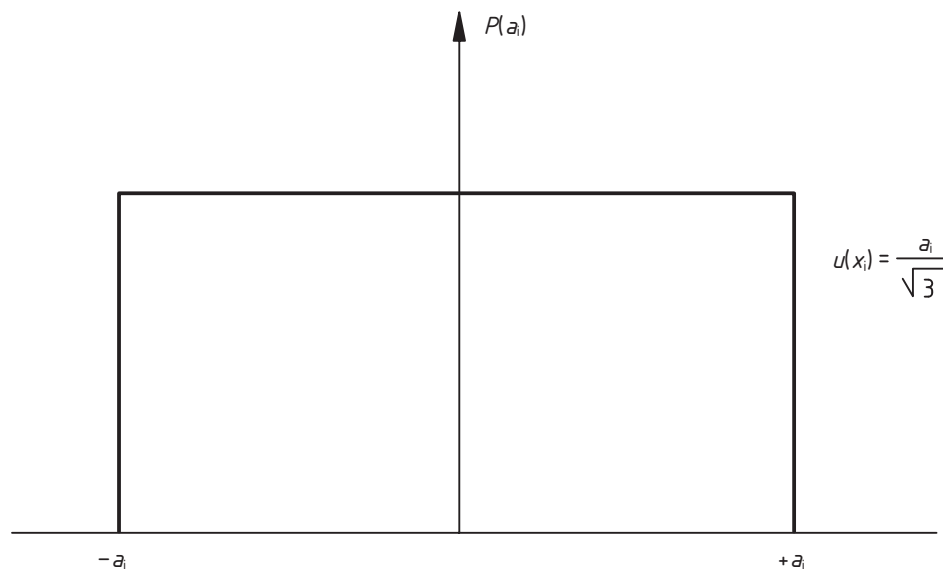

Figure B.3 — The rectangular distribution

#### B.6.4 The normal (Gaussian) probability distribution

The normal (or Gaussian) probability distribution is represented in Formula (B.6) and [Figure B.4](#).

$$u(x_{\text{mean}}) = \frac{u(\text{specified})}{k} \quad (\text{B.6})$$

where  $k$  is the coverage factor applying to the specified uncertainty value.

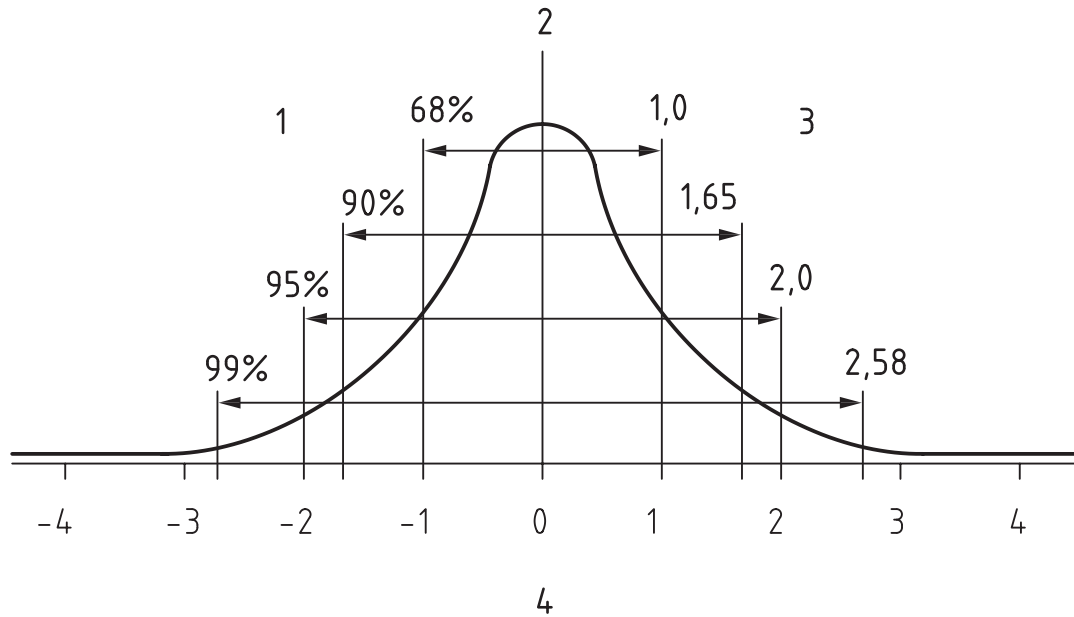

**Key**

- 1 percent of readings in bandwidth
- 2 probability
- 3 coverage factor
- 4 standard deviations

**Figure B.4 — The normal probability distribution**

These are uncertainty statements based on “off-line” statistical analysis, usually as part of a calibration process where they have been derived using a Type-A process. When expressed as standard uncertainty, the uncertainty value is to be used directly with an equivalent coverage factor of  $k = 1$ .

**B.6.5 The bimodal probability distribution**

The bimodal probability distribution is represented in Formula (B.7) and [Figure B.5](#). Measurement equipment with hysteresis can only exhibit values at the upper and lower bounds of the measurement. An example of this is the float mechanism, where friction and surface tension combine to cause the float to move in finite steps.

$$u(x_{\text{mean}}) = \frac{(x_{\text{max}} - x_{\text{min}})}{2} \tag{B.7}$$

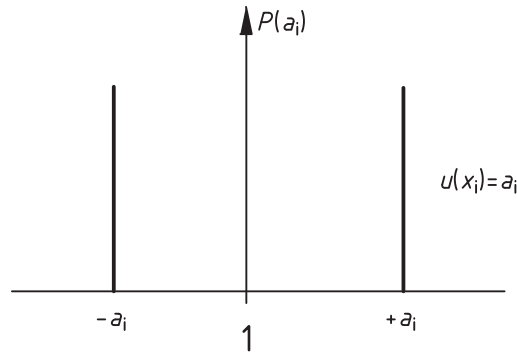

**Key**

1  $P(a_i)$

**Figure B.5 — The bimodal probability distribution**

**B.7 Combined uncertainty value,  $u_c$**

For most measurement systems, a measurement result is derived from several variables. For example, flow measurement  $Q$  in a rectangular channel can be expressed as a function of independent variables:

$$Q = b \times h \times \bar{v} \tag{B.8}$$

where

- $b$  is the channel width;
- $h$  is the depth of water in the channel;
- $\bar{v}$  is the mean velocity.

These three components are measured independently and combined to determine a value for  $Q$ .

Just as  $b$ ,  $h$ , and  $\bar{v}$  are combined to determine the value  $Q$ , so each component of uncertainty must be combined to determine a value for  $u_c(Q)$ . This is done by evaluating the sensitivity of  $Q$  to small change,  $\Delta$ , in  $b$ ,  $h$  or  $v$ . Thus:

$$\Delta Q = \frac{\partial Q}{\partial b} \Delta b + \frac{\partial Q}{\partial h} \Delta h + \frac{\partial Q}{\partial \bar{v}} \Delta \bar{v} \tag{B.9}$$

where the partial differentials,  $\frac{\partial Q}{\partial b}$ ,  $\frac{\partial Q}{\partial h}$  and  $\frac{\partial Q}{\partial \bar{v}}$ , are sensitivity coefficients.

For Formula (B.8) this is equal to

$$\frac{\Delta Q}{Q} = \frac{\Delta b}{b} + \frac{\Delta h}{h} + \frac{\Delta \bar{v}}{\bar{v}} \tag{B.10}$$

In uncertainty analysis, values  $\frac{\Delta Q}{Q}$ ,  $\frac{\Delta b}{b}$ ,  $\frac{\Delta \bar{v}}{\bar{v}}$ ,  $\frac{\Delta h}{h}$  correspond to dimensionless standard uncertainties.

They are given the notation  $u_c^*(Q)$ ,  $u^*(b)$ ,  $u^*(v)$  and  $u^*(h)$ . Since the uncertainties of  $b$ ,  $v$  and  $h$  are independent of each other, probability considerations require summation in quadrature.

$$u_c^*(Q) \cong \sqrt{u^*(\bar{v})^2 + u^*(b)^2 + u^*(h)^2} \quad (\text{B.11})$$

## **Annex C** (informative)

### **Sample measurement performance for use in hydrometric worked examples**

See [Table C.1](#).



**Table C.1**

Measurement technologies	Comment	Symbol	Uncertainty options		Installed equipment to have corresponding values certified by the manufacturer															
			A	B	Nominal range of measurement					Corresponding standard uncertainty (68 % confidence limit)										
			min.	25 %	50 %	75 %	max.	min.	25 %	50 %	75 %	max.								
Velocity (continuous)																				
Propeller	Calibration certificate	$u/(v)$	Yes	Normal	0,005 m/s	1,250 m/s	2,500 m/s	3,750 m/s	5,000 m/s	0,0005 m/s	0,010 m/s	0,022 m/s	0,030 m/s	0,040 m/s						
Electromagnetic	Calibration certificate	$u/(v)$	Yes	Normal	0,005 m/s	0,075 m/s	1,500 m/s	2,250 m/s	3,000 m/s	0,0005 m/s	0,010 m/s	0,018 m/s	0,025 m/s	0,025 m/s						
Path velocity																				
Time of flight	Sonic velocity path angle	$u/(v)$	Yes	Rectangular	0,030 m/s	0,250 m/s	0,500 m/s	0,750 m/s	1,000 m/s	0,003 m/s	0,005 m/s	0,007 m/s	0,007 m/s	0,010 m/s						
Gated Doppler sonar	Particle dependent – low velocity resolution	$u/(v)$	Yes	Rectangular	0,030 m/s	0,250 m/s	0,500 m/s	0,750 m/s	1,000 m/s	0,003 m/s	0,005 m/s	0,007 m/s	0,007 m/s	0,010 m/s						
Sonar correlation	Particle dependent	$u/(v)$	Yes	Rectangular	0,030 m/s	0,250 m/s	0,500 m/s	0,750 m/s	1,000 m/s	0,003 m/s	0,005 m/s	0,007 m/s	0,007 m/s	0,010 m/s						
EM	Calibrated <i>in situ</i>	$u/(v)$		Rectangular	0,030 m/s	0,250 m/s	0,500 m/s	0,750 m/s	1,000 m/s	0,003 m/s	0,005 m/s	0,007 m/s	0,007 m/s	0,010 m/s						
Water level (continuous)																				
Relative datum (shall be applied to all methods)	Manual process	$u(E)$		Triangular	N/A	0,500 m	1,000 m	1,500 m	2,000 m	0,001 m	0,001 m	0,001 m	0,001 m	0,001 m						
Encoder/float system	Requires regular maintenance	$u(h_1)$		Bi-modal	Extension 0,200 m	Extension 1,250 m	Extension 2,500 m	Extension 3,750 m	Extension 5,000 m	0,001 m	0,001 m	0,001 m	0,002 m	0,002 m						
Pressure transducer	Datum value drift	$u(h_1)$		Rectangular	0,010 m	0,500 m	1,000 m	1,500 m	2,000 m	0,002 m	0,002 m	0,002 m	0,002 m	0,002 m						
Sonar	Surface wave effects	$u(h_1)$	Yes	Rectangular	0,050 m	0,500 m	1,000 m	1,500 m	2,000 m	0,001 m	0,001 m	0,001 m	0,001 m	0,001 m						
Pulse echo ultrasound[2]	Surface wave effects/Air temperature compensation[3]	$u(R)$	Yes	Rectangular	Range 0,300 m	Range 1,250 m	Range 2,500 m	Range 3,750 m	Range 5,000 m	0,002 m	0,004 m	0,010 m	0,025 m	0,025 m						
Pulse echo opto/radar	Surface wave effects	$U(R)$		Rectangular	Range 0,300 m	Range 1,250 m	Range 2,500 m	Range 3,750 m	Range 5,000 m	0,002 m	0,004 m	0,010 m	0,025 m	0,025 m						
Gross-section profile (distance measurement)																				

Table C.1 (continued)

Measurement technologies	Comment	Symbol	Uncertainty options		Installed equipment to have corresponding values certified by the manufacturer									
			A	B	Nominal range of measurement					Corresponding standard uncertainty (68 % confidence limit)				
					min.	25 %	50 %	75 %	max.	min.	25 %	50 %	75 %	max.
Natural channels	Sonar or dip gauging/GPRS or tracking	$u(B)$			0,500 m	5,000 m	10,000 m	15,000 m	20,000 m	0,002 m	0,020 m	0,060 m	0,100 m	0,200 m
Man-made channels	Manual measurement	$u(B)$			N/A	0,500 m	1,000 m	1,500 m	2,000 m	0,001 m	0,001 m	0,0015 m	0,0015 m	0,0015 m

## Annex D (informative)

### Spreadsheets for use with this International Standard

#### D.1 General

Two spreadsheet files are provided for use with this International Standard at the following web address:

<http://standards.iso.org/iso/4359/>

- Flume 1** This spreadsheet covers trapezoidal and rectangular flumes, with trapezoidal and rectangular approach channels. A rectangular flume can have a trapezoidal approach or (albeit an unlikely scenario) vice versa. The flume invert can be flush with the approach channel floor ( $p = 0$ ) or can be raised above it.
- Flume 2** This spreadsheet covers a U-throated flume, with a U-shaped approach channel. Again, the flume invert can be flush with the approach channel floor ( $p = 0$ ) or can be raised above it.

The data entry cells *do not* include error trapping, to prevent inappropriate entries or combinations of entries from being made.

In order to avoid potential instability and other problems that can result in spreadsheets from the use of implicit equations to handle iterations, all iterations used in the spreadsheets are accomplished by setting out successive iterations in different rows or columns of the worksheets. No macros are used.

#### D.2 Structure of spreadsheets

Both spreadsheets are structured so that data are entered on only one worksheet, whose tab title is "Summary". This worksheet also includes the results of calculations of discharge for a single gauged head. The other worksheets contain detailed workings, together with the results of the stage-discharge rating calculations, in both tabular and graphical form.

The contents are tabulated in more detail in [Tables D.1](#) and [D.2](#). The U-throated flume spreadsheet contains worksheets that correspond to all those in the trapezoidal flume spreadsheet, plus a number of additional worksheets that are needed to handle the additional geometrical complexities.

**Table D.1 — Flume 1 — Spreadsheet for trapezoidal (and rectangular) flumes**

Worksheet	Contents
Summary	All the usual data to be entered covering the flume geometry The choice of whether to use the simple or detailed boundary layer approach The single gauged head for which the calculated discharge is required The results of the calculated discharge by three methods (see below): The calculated Froude numbers in the approach channel (for the single gauged head and the maximum in the rating table)
Rating	The stage-discharge rating table calculations and results (101 points)
Rating chart	A graph of the stage-discharge rating

**Table D.1** (continued)

Worksheet	Contents
Single	The detailed workings for the calculated discharge by three methods: 1 Coefficient method 2 Interpolated from the rating table 3 Iterative calculation using the rating table method
Shape	Calculation of a table of shape factor ( $C_s$ ) against $mH_e/b_e$ Interpolation of shape factors for use in the coefficient method
Shape chart	A graph of shape factor ( $C_s$ ) against $mH_e/b_e$
Delta-star	Calculations of $\delta^*/L$ values from Reynolds number ( $Re$ ) and $L/k_s$ for use in the coefficient method and in the rating table calculations

**Table D.2 — Flume 2 – Spreadsheet for U-throated flumes**

Worksheet	Contents
Summary	All the usual data to be entered covering the flume geometry The choice of whether to use the simple or detailed boundary layer approach The single gauged head for which the calculated discharge is required The results of the calculated discharge by three methods (see below): The calculated Froude numbers in the approach channel (for the single gauged head and the maximum in the rating table)
Rating	The stage-discharge rating table calculations and results (101 points)
Rating chart	A graph of the stage-discharge rating
Single	The detailed workings for the calculated discharge by three methods: 1 Coefficient method 2 Interpolated from the rating table 3 Iterative calculation using the rating table method
Shape	Calculation of a table of shape factor ( $C_s$ ) against $H_e/D_e$ Interpolation of shape factors for use in the coefficient method
Shape chart	A graph of shape factor ( $C_s$ ) against $H_e/D_e$
Throat	Calculation of a table of throat width factor ( $w_{ce}/D_e$ ) against $H_e/D_e$ Interpolation of throat width factors for use in the coefficient method
Throat chart	A graph of throat width factor ( $w_{ce}/D_e$ ) against $H_e/D_e$
Delta-star	Calculations of $\delta^*/L$ values from Reynolds number ( $Re$ ) and $L/k_s$ for use in the coefficient method and in the rating table calculations
Circular 1	Supplementary geometrical calculations for the flume throat used in the rating tables calculations
Circular 2a to 2e	Supplementary geometrical calculations for the flume approach channel (gauging section) used in the rating tables calculations, each individual worksheet being for a successive iteration

## Bibliography

- [1] ISO 748, *Hydrometry — Measurement of liquid flow in open channels using current-meters or floats*
- [2] ISO 4373, *Hydrometry — Water level measuring devices*
- [3] ISO 5168, *Measurement of fluid flow — Procedures for the evaluation of uncertainties*
- [4] ISO/TS 24154, *Hydrometry — Measuring river velocity and discharge with acoustic Doppler profilers*
- [5] ISO/TS 25377, *Hydrometric uncertainty guidance (HUG)*
- [6] ISO/IEC Guide 98-3, *Uncertainty of measurement — Part 3: Guide to the expression of uncertainty in measurement (GUM:1995)*
- [7] ISO 26906, *Hydrometry — Fishpasses at flow measurement structures*
- [8] ISO/IEC 17025, *General requirements for the competence of testing and calibration laboratories*
- [9] Ackers P., White W.R., Perkins J.A., Harrison A.J.M. *Weirs and flumes for flow measurement*. J Wiley & Sons, 1978, 327 p.
- [10] Ackers P., Harrison A.J.M. *Critical-depth flumes for flow measurement in open channels*, Hydraulics Research paper No 5, Department of Scientific and Industrial Research, HMSO, 1963
- [11] Tyler D.K. *Open channel flow measurement*, Report EX 5591, HR Wallingford, August 2007, 55pp





# British Standards Institution (BSI)

BSI is the national body responsible for preparing British Standards and other standards-related publications, information and services.

BSI is incorporated by Royal Charter. British Standards and other standardization products are published by BSI Standards Limited.

## About us

We bring together business, industry, government, consumers, innovators and others to shape their combined experience and expertise into standards-based solutions.

The knowledge embodied in our standards has been carefully assembled in a dependable format and refined through our open consultation process. Organizations of all sizes and across all sectors choose standards to help them achieve their goals.

## Information on standards

We can provide you with the knowledge that your organization needs to succeed. Find out more about British Standards by visiting our website at [bsigroup.com/standards](http://bsigroup.com/standards) or contacting our Customer Services team or Knowledge Centre.

## Buying standards

You can buy and download PDF versions of BSI publications, including British and adopted European and international standards, through our website at [bsigroup.com/shop](http://bsigroup.com/shop), where hard copies can also be purchased.

If you need international and foreign standards from other Standards Development Organizations, hard copies can be ordered from our Customer Services team.

## Subscriptions

Our range of subscription services are designed to make using standards easier for you. For further information on our subscription products go to [bsigroup.com/subscriptions](http://bsigroup.com/subscriptions).

With **British Standards Online (BSOL)** you'll have instant access to over 55,000 British and adopted European and international standards from your desktop. It's available 24/7 and is refreshed daily so you'll always be up to date.

You can keep in touch with standards developments and receive substantial discounts on the purchase price of standards, both in single copy and subscription format, by becoming a **BSI Subscribing Member**.

**PLUS** is an updating service exclusive to BSI Subscribing Members. You will automatically receive the latest hard copy of your standards when they're revised or replaced.

To find out more about becoming a BSI Subscribing Member and the benefits of membership, please visit [bsigroup.com/shop](http://bsigroup.com/shop).

With a **Multi-User Network Licence (MUNL)** you are able to host standards publications on your intranet. Licences can cover as few or as many users as you wish. With updates supplied as soon as they're available, you can be sure your documentation is current. For further information, email [bsmusales@bsigroup.com](mailto:bsmusales@bsigroup.com).

## BSI Group Headquarters

389 Chiswick High Road London W4 4AL UK

## Revisions

Our British Standards and other publications are updated by amendment or revision.

We continually improve the quality of our products and services to benefit your business. If you find an inaccuracy or ambiguity within a British Standard or other BSI publication please inform the Knowledge Centre.

## Copyright

All the data, software and documentation set out in all British Standards and other BSI publications are the property of and copyrighted by BSI, or some person or entity that owns copyright in the information used (such as the international standardization bodies) and has formally licensed such information to BSI for commercial publication and use. Except as permitted under the Copyright, Designs and Patents Act 1988 no extract may be reproduced, stored in a retrieval system or transmitted in any form or by any means – electronic, photocopying, recording or otherwise – without prior written permission from BSI. Details and advice can be obtained from the Copyright & Licensing Department.

## Useful Contacts:

### Customer Services

**Tel:** +44 845 086 9001

**Email (orders):** [orders@bsigroup.com](mailto:orders@bsigroup.com)

**Email (enquiries):** [cservices@bsigroup.com](mailto:cservices@bsigroup.com)

### Subscriptions

**Tel:** +44 845 086 9001

**Email:** [subscriptions@bsigroup.com](mailto:subscriptions@bsigroup.com)

### Knowledge Centre

**Tel:** +44 20 8996 7004

**Email:** [knowledgecentre@bsigroup.com](mailto:knowledgecentre@bsigroup.com)

### Copyright & Licensing

**Tel:** +44 20 8996 7070

**Email:** [copyright@bsigroup.com](mailto:copyright@bsigroup.com)



...making excellence a habit.™