

BS ISO 4302:2016



BSI Standards Publication

Cranes — Wind load assessment

National foreword

This British Standard is the UK implementation of ISO 4302:2016.

The UK participation in its preparation was entrusted to Technical Committee MHE/3/1, Crane design.

A list of organizations represented on this committee can be obtained on request to its secretary.

This publication does not purport to include all the necessary provisions of a contract. Users are responsible for its correct application.

© The British Standards Institution 2017.
Published by BSI Standards Limited 2017

ISBN 978 0 580 81289 7

ICS 53.020.20

Compliance with a British Standard cannot confer immunity from legal obligations.

This British Standard was published under the authority of the Standards Policy and Strategy Committee on 28 February 2017.

Amendments/corrigenda issued since publication

Date	Text affected
------	---------------

INTERNATIONAL
STANDARD

BS ISO 4302:2016

ISO
4302

Second edition
2016-10-01

Cranes — Wind load assessment

Appareils de levage à charge suspendue — Évaluation des charges dues au vent



Reference number
ISO 4302:2016(E)

© ISO 2016

Contents

Page

Foreword	iv
1 Scope	1
2 Normative references	1
3 Terms, definitions, symbols and abbreviated terms	1
4 Wind pressure	2
5 In-service wind	3
5.1 General.....	3
5.2 Action of in-service wind on suspended load.....	3
5.3 Wind load calculations.....	4
5.4 Shape coefficients for individual members, frames, etc.....	4
5.5 Shielding factors — Multiple frames or members.....	5
5.6 Wind loads on individual members (inclined to the wind direction).....	7
6 Out-of-service wind	7
6.1 General.....	7
6.2 Loads due to out-of-service wind.....	8
6.3 Equivalent static out-of-service wind pressure.....	8
6.4 Wind loads on individual members (inclined to the wind direction).....	9
6.5 Storm wind maps.....	9
Annex A (informative) Reference storm wind speeds	11
Bibliography	22

Foreword

ISO (the International Organization for Standardization) is a worldwide federation of national standards bodies (ISO member bodies). The work of preparing International Standards is normally carried out through ISO technical committees. Each member body interested in a subject for which a technical committee has been established has the right to be represented on that committee. International organizations, governmental and non-governmental, in liaison with ISO, also take part in the work. ISO collaborates closely with the International Electrotechnical Commission (IEC) on all matters of electrotechnical standardization.

The procedures used to develop this document and those intended for its further maintenance are described in the ISO/IEC Directives, Part 1. In particular the different approval criteria needed for the different types of ISO documents should be noted. This document was drafted in accordance with the editorial rules of the ISO/IEC Directives, Part 2 (see www.iso.org/directives).

Attention is drawn to the possibility that some of the elements of this document may be the subject of patent rights. ISO shall not be held responsible for identifying any or all such patent rights. Details of any patent rights identified during the development of the document will be in the Introduction and/or on the ISO list of patent declarations received (see www.iso.org/patents).

Any trade name used in this document is information given for the convenience of users and does not constitute an endorsement.

For an explanation on the meaning of ISO specific terms and expressions related to conformity assessment, as well as information about ISO's adherence to the World Trade Organization (WTO) principles in the Technical Barriers to Trade (TBT) see the following URL: www.iso.org/iso/foreword.html.

The committee responsible for this document is ISO/96, *Cranes*, Subcommittee SC 10, *Design principles and requirements*

This second edition cancels and replaces the first edition (ISO 4302:1981), which has been technically revised. All clauses have been technically revised to be aligned with ISO 20332, in combination with ISO 8686-1, and the informative [Annex A](#), "Wind maps", has been added.

Cranes — Wind load assessment

1 Scope

This International Standard specifies the assessment of wind loads on cranes.

It establishes general methods for calculating wind loads (for in-service and out-of-service conditions), which are included in the load combinations stated in ISO 8686-1 and used for proofs of competence such as those given in ISO 20332 for the structural components of cranes.

It provides a simplified method of calculation and assumes that

- the wind may blow horizontally from any direction,
- the wind blows at a constant speed,
- there is a static reaction to the wind load applied to the crane structure.

It includes built-in allowances for the effects of gusting (fluctuation in wind speed) and for dynamic response.

It gives guidance on when to secure the crane for out-of-service conditions.

2 Normative references

The following documents, in whole or in part, are normatively referenced in this document and are indispensable for its application. For dated references, only the edition cited applies. For undated references, the latest edition of the referenced document (including any amendments) applies.

ISO 8686-1:2012, *Cranes — Design principles for loads and load combinations — Part 1: General*

3 Terms, definitions, symbols and abbreviated terms

For the purposes of this document, the following terms and definitions apply. The main symbols are given in [Table 1](#).

3.1

in-service wind

maximum wind that the crane is designed to withstand under operating conditions

3.2

out-of-service wind

maximum (storm) wind blowing from the least favourable direction that a crane is designed to withstand when in an out-of-service condition

Table 1 — Main symbols

Symbol	Description
A	Characteristic area
A_H	Wind area of the suspended load
C_f, c_H	Shape coefficients
D	Diameter of a circular section
F	Wind load
f_{rec}	Recurrence interval factor
K	Terrain-roughness-coefficient
F_H	Wind load due to the wind on the hoist load
m_H	Mass of the gross or hoist load in kilograms
p	In-service wind pressure
$q(z)$	Equivalent static out-of-service wind pressure at height z
R	Recurrence interval
v_g	3 s gust amplitude
v_s	Wind speed, used as a basis of the calculation
v_s^*	Wind speed component acting perpendicularly to the longitudinal axis or surface of a member
$v(z)$	Equivalent static out-of-service wind speed at the height z
$v(z)^*$	Wind speed component acting perpendicularly to the longitudinal axis of a member at height z
$v_m(z)$	10 min mean storm wind speed at height z , in metres per second
v_{ref}	Reference storm wind speed
z	Height above the surrounding ground level, in metres
Φ_g	Gust response factor
θ	Angle of the wind direction to the longitudinal axis or face ($\theta < 90^\circ$)
η	Shielding factor
η_w	Factor for the remaining hoist load in out-of-service condition
ρ	Density of the air

4 Wind pressure

The wind pressure, p , is given by the formula

$$p = 0,5 \times \rho \times v_s^2 \quad (1)$$

where

ρ is the density of air which, for design purposes, is assumed to be constant $\rho = 1,225 \text{ kg/m}^3$;

v_s is the wind speed, used as a basis of the calculation.

When using the international system of units (SI), where p is expressed in N/m^2 and v_s in metres per second (m/s), the following applies:

$$p = 0,625 \times v_s^2 \quad (2)$$

5 In-service wind

5.1 General

The wind loading shall be applied in the least favourable direction in combination with the appropriate loads as defined in ISO 8686-1:2012, load combinations B and C.

In-service design wind speeds and corresponding pressures shall be either selected based on [Table 2](#) or specified based on the crane configuration, application and the wind conditions. The in-service design wind speed shall be documented in the operating manual of the crane.

Table 2 — In-service design wind speeds v_s and pressures p

Type of crane or application	Design wind speed v_s m/s	Design wind pressure p N/m ²
Cranes that are easily secured against wind action and which are designed for operation in light winds only (e.g. cranes of low chassis height with booms that can be readily lowered to the ground)	14	125
All normal types of crane installed in the open	20	250
Cranes in process applications, where a crane must continue to work in high winds	28,5	500

The wind speed shall be measured at the highest point of the crane. The in-service design wind speed in [Table 2](#) is based on the premise that the crane can be fully secured in an out-of-service configuration before the design wind speed is exceeded. As the means for this securing vary by crane type and configuration, the time allowance (e.g. locking devices at special locations of the crane runway, hand-operated or automatic rail clamps) shall take this into account by a lower level of wind speed chosen to start the securing. Wind speeds for the use of different crane configurations and for the starting of securing shall be specified.

5.2 Action of in-service wind on suspended load

On all cranes, the action of the wind on the load must be taken into account and the method by which this is done shall be clearly described. This may be accomplished by use of wind loads on load parameters of size and shape. The wind load F_H on the load shall be calculated as a minimum as follows:

$$F_H = c_H \times A_H \times p \quad (3)$$

where

F_H is the wind load on the suspended load *in the direction of the wind*;

c_H is the shape coefficient of the suspended load;

A_H is the wind area of the hoist load;

p is the wind pressure corresponding to appropriate design condition.

In the absence of detailed information on the load it shall be assumed that $c_H = 2,4$ and $A_H = 0,000\ 5 \times m_H$, where A_H is expressed in square metres (m²) and m_H is the mass of the hoist load in kilograms (kg).

Additionally, the effects of wind actions on the load may be limited by

- a reduction of the rated load based upon wind speed, load area and shape factor,
- a limitation of the in-service wind speed for loads exceeding a stipulated surface area.

5.3 Wind load calculations

For crane structures or individual members used in crane structures the wind load, F , in the direction of the wind, is calculated from the formula:

$$F = A \times p \times C_f \quad (4)$$

where

- F is the wind load acting perpendicularly to the longitudinal axis of the member (see 5.6)
- A is the characteristic area, i.e. the projection of the solid area of the member on to a plane perpendicular to the wind direction;
- p is the wind pressure corresponding to appropriate design condition;
- C_f is the shape coefficient for the member under consideration, with reference to the wind direction and the characteristic area (see 5.4). Values shall be either those given in Table 3 or those derived by recognized theoretical or experimental methods (e.g. wind tunnel or full scale tests), or other recognized sources.

The total wind load on the structure is taken as the sum of the loads on its members.

5.4 Shape coefficients for individual members, frames, etc

Shape coefficients, C_f , for individual members, single lattice frames, and machinery houses, etc. vary according to the aerodynamic slenderness and, in the case of large box sections, with the section ratio. Aerodynamic slenderness and section ratio are defined in Figure 1.

Where a frame is made up of flat-sided and circular sections, or of circular sections in both flow regimes ($D \times v_s < 6 \text{ m}^2/\text{s}$ and $D \times v_s \geq 6 \text{ m}^2/\text{s}$, with D the diameter of a circular section in metres, and v_s the design wind speed in metres per second, the appropriate shape coefficients are applied to the corresponding frontal areas.

Table 3 — Shape coefficients C_f per aerodynamic slenderness

Type	Description	Aerodynamic slenderness l/b or l/D (see Figure 1)						
		5	10	20	30	40	50	
Individual members	Rolled sections, rectangles, hollow sections, flat plates	1,3	1,35	1,6	1,65	1,7	1,9	
	Circular sections where $D \times v_s < 6 \text{ m}^2/\text{s}$	0,75	0,80	0,90	0,95	1,0	1,1	
	Circular sections where $D \times v_s \geq 6 \text{ m}^2/\text{s}$	0,60	0,65	0,70	0,70	0,75	0,8	
	Box sections over 350 mm square and 250 mm, 450 mm rectangular	b/d						
		≥ 2	1,55	1,75	1,95	2,1	2,2	
		1	1,40	1,55	1,75	1,85	1,9	
0,5		1,0	1,2	1,3	1,35	1,4		
	0,25	0,8	0,9	0,9	1,0	1,0		
Single lattice frames	Flat sided sections	1,7						
	Circular sections where $D \times v_s < 6 \text{ m}^2/\text{s}$	1,2						
	Circular sections where $D \times v_s \geq 6 \text{ m}^2/\text{s}$	0,8						
Machinery houses, etc.	Rectangular clad structures on ground or solid base (air flow beneath structure prevented)	1,1						

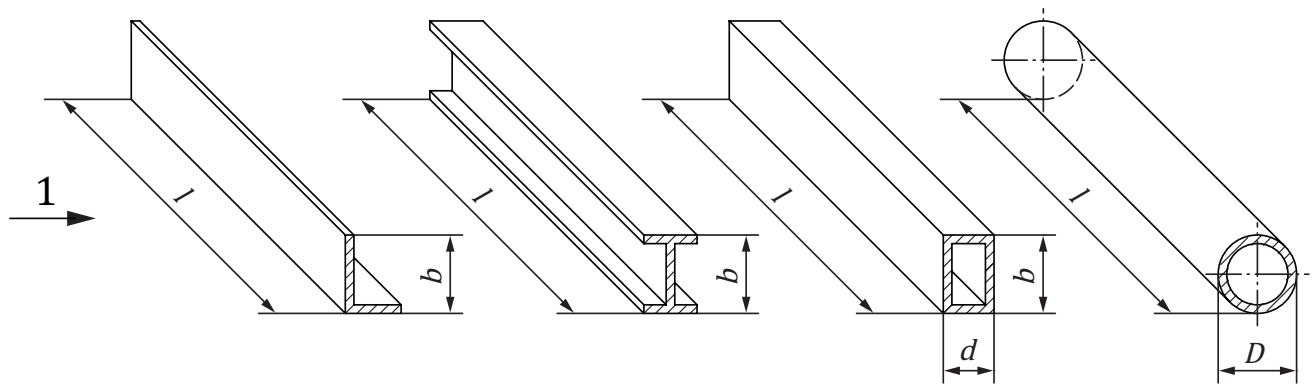

$$\text{Aerodynamic slenderness length of member} = \frac{\text{length of member}}{\text{breadth } b \text{ section across wind front}} = \frac{l}{b} \text{ or } \frac{l}{D}$$

$$\text{Section ratio (for box sections)} = \frac{\text{breadth of section across wind front}}{\text{depth of section parallel to wind flow}} = \frac{b}{d}$$

Key

1 wind direction

Figure 1 — Aerodynamic slenderness and section ratio

5.5 Shielding factors — Multiple frames or members

Where parallel frames or members are positioned so that shielding takes place, the wind load on the windward frame or member and on the unsheltered parts of those behind it are calculated using the appropriate shape coefficients. The shape coefficients on the sheltered parts are multiplied by a shielding factor, η , given in [Table 4](#). Values of η vary with the solidity and spacing ratios as defined in [Figure 2](#).

Table 4 — Shielding factors (η)

Spacing ratio a/b	Solidity ratio (see Figure 2) A/A_e					
	0,1	0,2	0,3	0,4	0,5	$\geq 0,6$
0,5	0,75	0,4	0,32	0,21	0,15	0,1
1,0	0,92	0,75	0,59	0,43	0,25	0,1
2,0	0,95	0,8	0,63	0,5	0,33	0,2
4,0	1	0,88	0,76	0,66	0,55	0,45
5,0	1	0,95	0,88	0,81	0,75	0,68
6,0	1	1	1	1	1	1

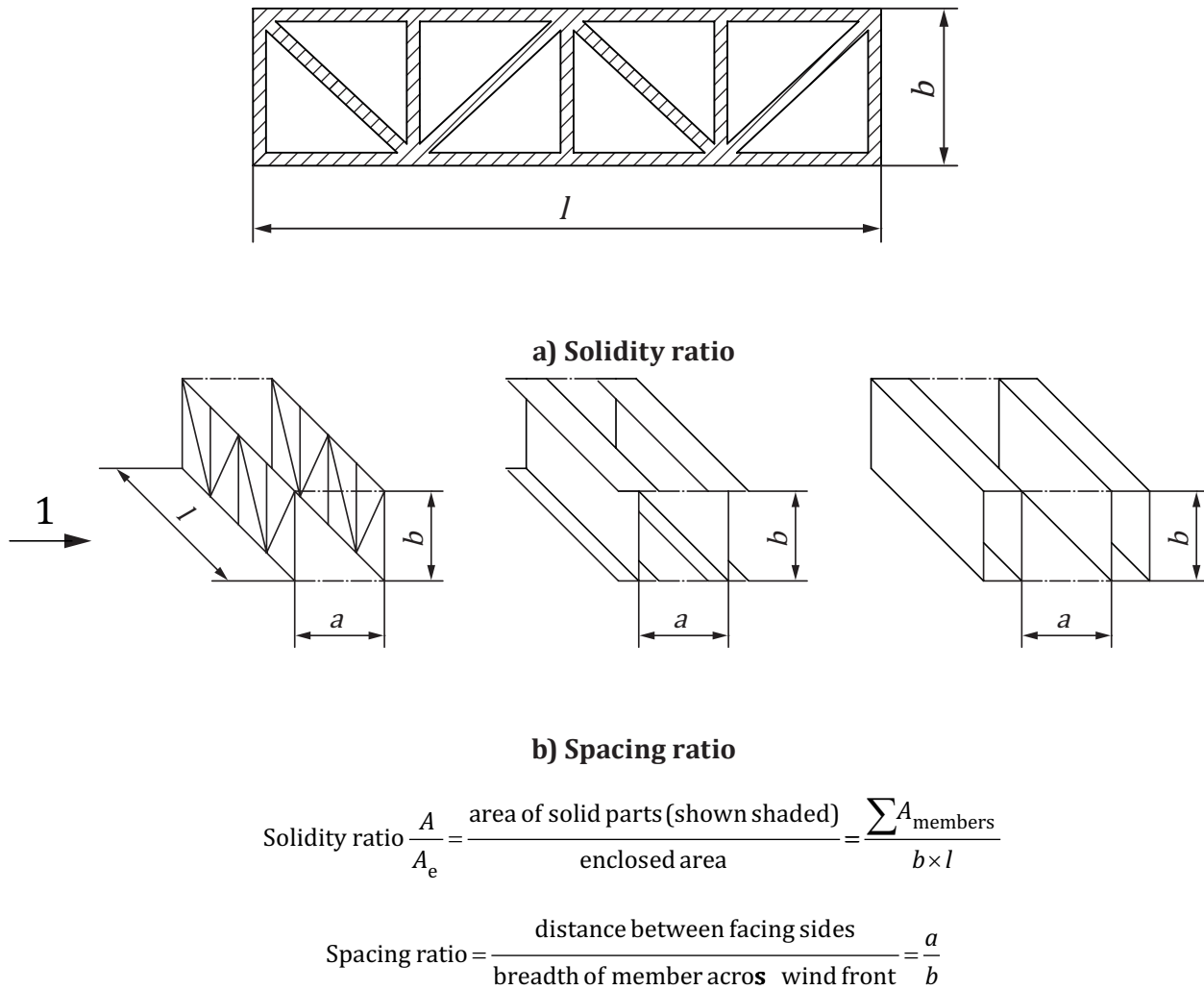

Key
 1 wind direction

Figure 2 — Solidity ratio and spacing ratio

Where there are a number of identical frames or members spaced equidistantly behind one another in such a way that each frame shields those behind it, it is accepted that the shielding effect increases up to the ninth frame and remains constant thereafter. The wind loads are calculated from [Formulae \(5\)](#) and [\(6\)](#).

On the first eight frames:

$$F_n = \frac{1 - \eta^n}{1 - \eta} \times A \times p \times C_f \tag{5}$$

where

- F_n is the wind load on the n th frame;
- η is the shielding factor;
- A is the characteristic area, i.e. the projection of the solid area of the member on to a plane perpendicular to the wind direction;
- p is the wind pressure corresponding to appropriate design condition;
- C_f is the shape coefficient for the member under consideration, with reference to the wind direction and the characteristic area (see 5.4). Values shall be either those given in Table 3 or those derived by recognized theoretical or experimental methods (e.g. wind tunnel or full scale tests), or other recognized sources.

On the 9th and subsequent frames:

$$F_{(n \geq 9)} = \left[\frac{1 - \eta^9}{1 - \eta} + (n - 9) \times \eta^8 \right] \times A \times p \times C_f \quad (6)$$

For design purposes the term η^x used in Formulae (5) and (6) shall be taken as 0,10 whenever it is numerically less than 0,10.

5.6 Wind loads on individual members (inclined to the wind direction)

Where the wind blows at an angle to the longitudinal axis of a member or to its surface, the wind load acting *perpendicularly to the longitudinal axis or surface* is obtained by using, in Formula (1), the wind speed component v_s^* calculated by

$$v_s^* = v_s \times \sin \theta \quad (7)$$

where

- v_s^* is the wind speed component acting perpendicularly to the longitudinal axis or surface;
- v_s is the wind speed, used as a basis of the calculation;
- θ is the angle of the wind to the longitudinal axis or surface ($\theta < 90^\circ$).

6 Out-of-service wind

6.1 General

The speed of the out-of-service wind (3.2) varies with the geographical location and the degree of exposure to prevailing winds.

Cranes with parts that can be readily lowered to the ground, e.g. with telescoping jibs or with towers that are readily telescoped by means of self-contained mechanisms, or cranes allowed to weathervane (self-aligning into a most favourable position), need only be designed for out-of-service wind in this position. Operating instructions for such cranes shall include the requirement that all parts be secured from wind exposure when not in service.

The operating instructions for cranes that require the installation of wind stabilizers, or other means not used during operation, in order to resist the specified out-of-service wind speed shall state the wind speed that the crane can safely sustain in its operating configuration; they shall also describe the provisions that must be followed in order that the crane may safely withstand the specified out-of-service wind.

6.2 Loads due to out-of-service wind

For the calculation of loads acting on a crane due to out-of-service wind, it is assumed that the wind blows horizontally at a speed increasing with the height above the surrounding ground level.

The out-of-service wind loads assumed to act on a member of a crane and/or on the hoist load remaining suspended from the crane shall be calculated by

$$F = q(z) \times C_f \times A \quad (8)$$

where

$q(z)$ is the equivalent static out-of-service wind pressure at height z ;

for a member of the crane

F is the wind load acting *perpendicularly to the longitudinal axis* of the crane member;

C_f is the shape coefficient of the member under consideration (see [Clause 5](#));

A is the area of the member under consideration;

for the hoist load remaining suspended from the crane

F is the wind load, acting on the remaining hoist load in direction of the wind speed;

C_f is the shape coefficient of the remaining hoist load in direction of the wind speed;

A is the maximum possible area of the remaining hoist load.

In the absence of detailed information of the remaining load it shall be assumed that $C_f = 2,4$ and $A = 0,000\,5 \times \eta_w \times m_H$, where m_H is the mass of the hoist load in kilograms and η_w is the factor ($0 \leq \eta_w \leq 1$) for the remaining hoist load in the out-of-service condition.

6.3 Equivalent static out-of-service wind pressure

The equivalent static out-of-service wind pressure at height z is calculated by

$$q(z) = 0,5 \times \rho \times v(z)^2 \quad (9)$$

where

ρ is the density of the air, set to $\rho = 1,225 \text{ kg/m}^3$;

$v(z)$ is the equivalent static out-of-service wind speed at height z

$$v(z) = f_{\text{rec}} \times \left[\frac{v_m(z)}{v_{\text{ref}}} + \Phi_8 \times \frac{v_g}{v_{\text{ref}}} \right] \times v_{\text{ref}} \quad (10)$$

where

f_{rec} is a factor depending on the recurrence interval R ; for crane design in general an out-of-service wind, which may recur once in intervals of 5 years to 50 years ($R = 5$ to $R = 50$) should be selected on the basis of the crane duration on the site of installation:

$$\begin{aligned} f_{\text{rec}} &= 0,815\ 5 && \text{for } R = 5; \\ f_{\text{rec}} &= 0,873\ 3 && \text{for } R = 10; \\ f_{\text{rec}} &= 0,946\ 3 && \text{for } R = 25; \\ f_{\text{rec}} &= 1,0 && \text{for } R = 50; \end{aligned}$$

$v_{\text{m}}(z)$ is the 10 min mean storm wind speed at height z , in metres per second;

v_{ref} is the reference storm wind speed, in metres per second, depending on the particular geographical region, and which is defined as the mean storm wind speed with a recurrence interval of once in 50 years, measured at 10 m above flat open country, and averaged over a period of 10 min;

Φ_8 is the gust response factor (Φ_8 may be simplified to $\Phi_8 = 1,1$);

v_{g} is a 3 s gust amplitude beyond the 10 min mean storm wind.

[Formula \(10\)](#) may be simplified using, conservatively, factors of flat open country, as

$$v(z) = f_{\text{rec}} \times [(z/10)^{0,14} + 0,4] \times v_{\text{ref}} \quad (11)$$

Applying conservative assumptions:

$$v_{\text{g}} = v_{\text{ref}} \times 2 \times \sqrt{6 \times K} \quad \text{and}$$

K is the terrain-roughness-coefficient, set to $K = 0,0055$ and the gust response factor $\Phi_8 = 1,1$.

6.4 Wind loads on individual members (inclined to the wind direction)

For a crane member, the component $v(z)^*$ of the wind speed acting perpendicularly to the longitudinal axis of the crane member shall be applied. The wind load perpendicular to the area of the member shall be calculated by [Formula \(9\)](#) using the wind speed component calculated by

$$v(z)^* = v(z) \times \sin\theta \quad (12)$$

where

θ is the angle between the direction of the wind speed $v(z)$ and the longitudinal axis of the member under consideration;

z is the height above the surrounding ground level, in metres;

For the hoist load remaining suspended from the crane, the substitution of $v(z)$ by $v(z)^*$ shall not be applied.

6.5 Storm wind maps

Storm wind maps and storm wind speeds are given in [Annex A](#), indicating the regions in which the same reference storm wind speeds are applicable.

Where cranes are installed or used for extended periods in areas where, due to the local topographical configurations, the out-of-service wind is expected to be more severe than indicated in [Annex A](#), the

equivalent static out-of-service wind speeds and pressures, calculated by the equations given above, shall be modified according to meteorological data and/or aerodynamical considerations.

More detailed (national) wind maps or local meteorological data, based on the assumptions of this clause, may be used as sources for the reference storm wind speed, v_{ref} [see [Formula \(10\)](#)].

Annex A (informative)

Reference storm wind speeds

A.1 Europe

A.1.1 France

See [Figure A.1](#) and [Table A.1](#).

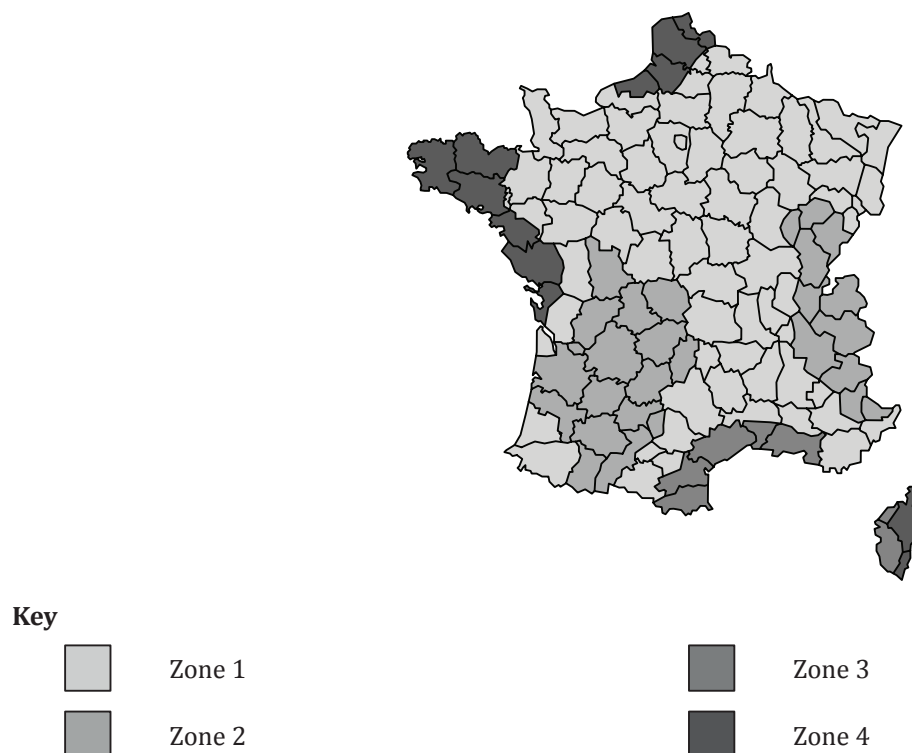

Figure A.1 — Map of metropolitan departments of France indicating regions where the same reference storm wind speeds are applicable

Table A.1 — Reference storm wind speeds, v_{ref} , in France

Zone label or region name	Metropolitan department (see Figure A.1)				Overseas department			
	1	2	3	4	Guadeloupe	Guyane	Martinique	Réunion
v_{ref} [m/s]	22	24	26	28	36	17	32	34

A.1.3 Spain

See [Figure A.2](#) and [Table A.2](#).



Key

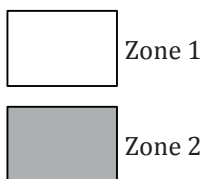

Figure A.2 — Map of Spain indicating regions where the same reference storm wind speeds are applicable

Table A.2 — Reference storm wind speeds, v_{ref} , in Spain

Zone label or region name	Iberian peninsula (see Figure A.2)		Balearic Islands	Canary Islands	North Africa (coast/shore)
	1	2	Not included in Figure A.2		
v_{ref} [m/s]	24	25	28	28	28

A.1.5 Ireland

See [Figure A.3](#) and [Table A.3](#).



Figure A.3 — Map of Ireland indicating regions where the same reference storm wind speeds are applicable

Table A.3 — Reference storm wind speeds, v_{ref} , in Ireland

Zone label or region name	1	2
v_{ref} [m/s]	32	36

A.1.7 The Netherlands

See [Figure A.4](#) and [Table A.4](#).



Key

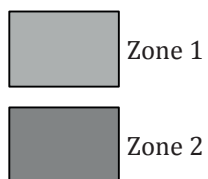

Figure A.4 — Map of The Netherlands indicating regions where the same reference storm wind speeds are applicable

Table A.4 — Reference storm wind speeds, v_{ref} , in The Netherlands

Zone label or region name	1	2
v_{ref} [m/s]	28	32

A.1.9 Sweden

See [Figure A.5](#) and [Table A.5](#).

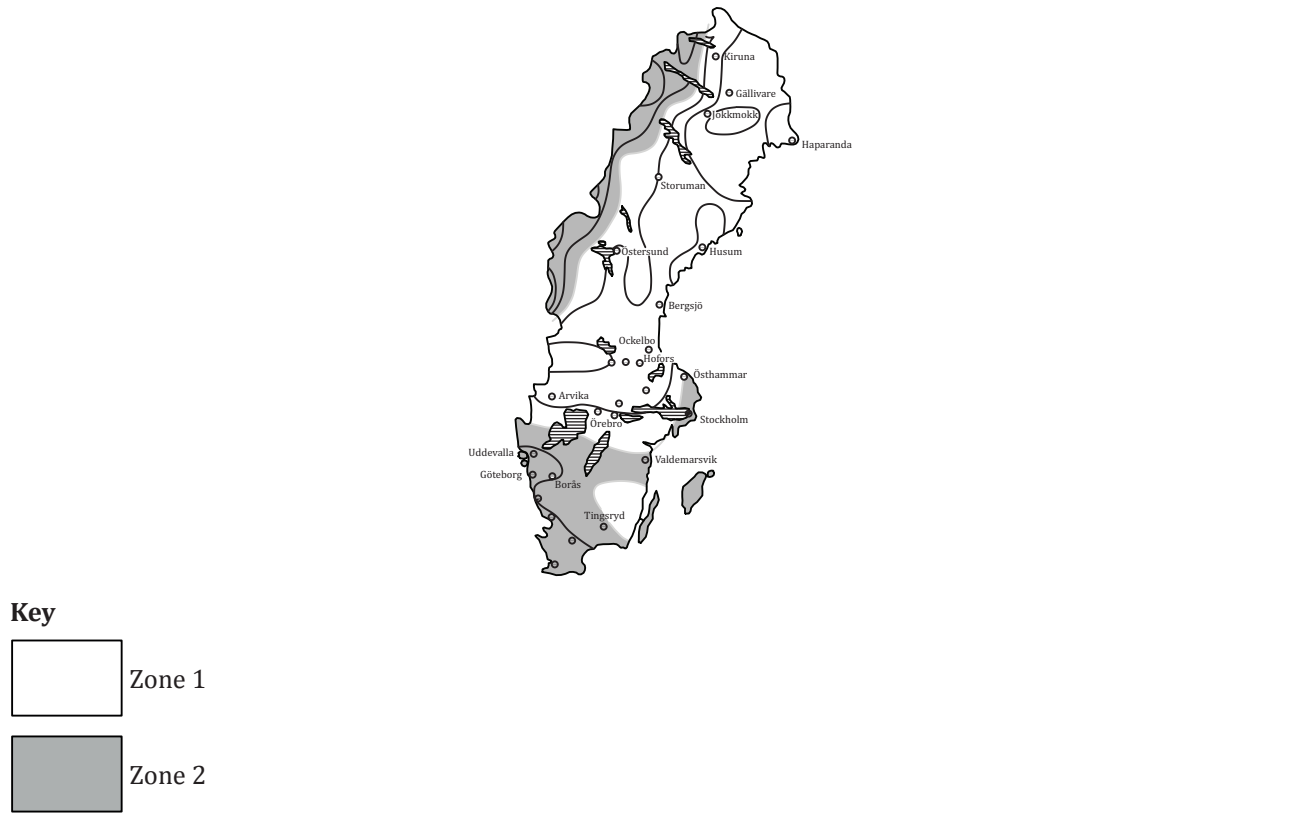

Figure A.5 — Map of Sweden indicating regions where the same reference storm wind speeds are applicable

Table A.5 — Reference storm wind speeds, v_{ref} , in Sweden

Zone label or region name	1	2
v_{ref} [m/s]	24	28

A.1.10 Switzerland

See [Figure A.6](#) and [Table A.6](#).

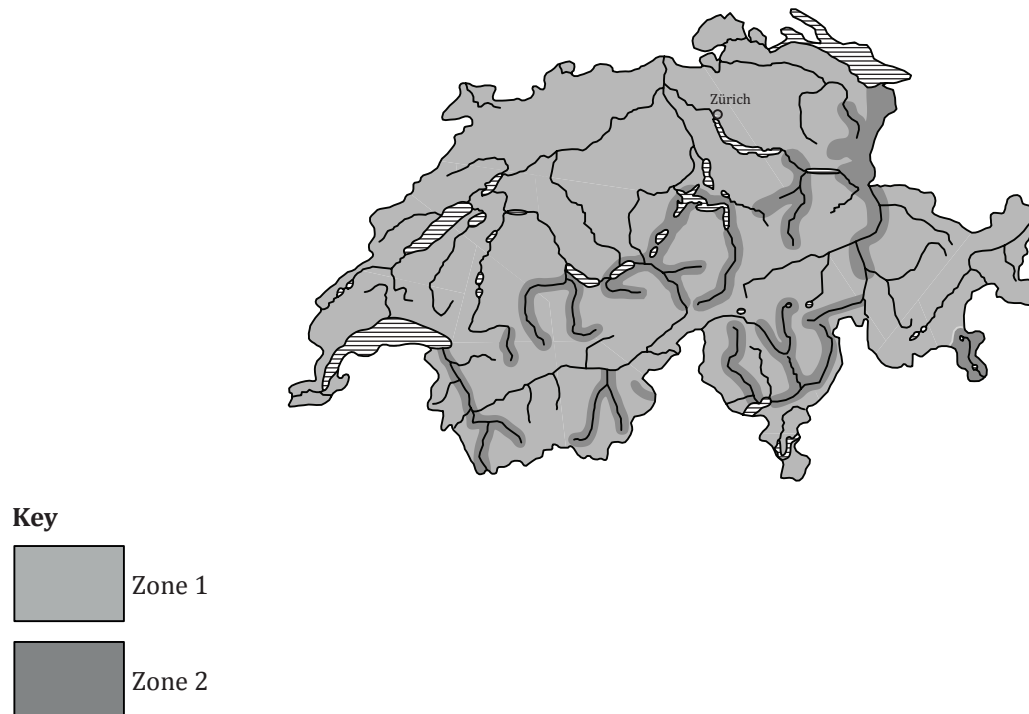

Figure A.6 — Map of Switzerland indicating regions where the same reference storm wind speeds are applicable

Table A.6 — Reference storm wind speeds, v_{ref} , in Switzerland

Zone label or region name	1	2
v_{ref} [m/s]	28	32

Key



Zone 1



Zone 3



Zone 2



Zone 4

Figure A.7 — Map of Germany indicating regions where the same reference storm wind speeds are applicable

Table A.7 — Reference storm wind speeds, v_{ref} in Germany

Zone label or region name (see Figure A.7)	1	2	3	4
v_{ref} [m/s]	22,5	25,0	27,5	30,0

A.1.13 European regions

In the absence of specific data or relevant national maps, the rough storm wind map of Europe shown in [Figure A.8](#) can be used. See [Table A.8](#).



Figure A.8 — Map of Europe indicating regions where the same reference storm wind speeds are applicable

Table A.8 — Reference storm wind speeds, v_{ref} , in European regions

Zone label or region name (see Figure A.8)	A/B	C	D	E
v_{ref} [m/s]	24,0	28,0	32,0	36,0

Special conditions should be agreed upon for cranes used in Zone F, where $v_{ref} \geq 36$ m/s. Cranes likely to be used in different regions should be designed for the conditions applicable in those regions.

Key



Figure A.9 — Map of the USA indicating regions where the same reference storm wind speeds are applicable

Table A.9 — Reference storm wind speeds, v_{ref} , in the USA

Zone label or region name (see Figure A.9)	1	2	3	4	5	6	7	8	9
v_{ref} [m/s]	21,33	22,58	25,09	27,60	30,11	32,62	35,13	37,64	> 37,64

NOTE No values given for special wind zones

Key

	Zone A1		Zone A5
	Zone A2		Zone B
	Zone A3		Zone C
	Zone A4		Zone D

Figure A.10 — Map of Australia indicating regions where the same reference storm wind speeds are applicable

Table A.10 — References storm wind speeds, v_{ref} , in Australia

Zone label or region name (see Figure A.10)	Region			
	Non-cyclonic		Cyclonic	
	A1 to A5	B	C	D
v_{ref} [m/s]	28,3	31,9	37,8	43,6

Key



	Zone A6
	Zone A7
	Zone W

Figure A.11 — Map of New Zealand indicating regions where the same reference storm wind speeds are applicable

Table A.11 — Reference storm wind speeds, v_{ref} , in New Zealand

Zone label or region name (see Figure A.11)	Region (non-cyclonic)	
	A (6 to 7)	W
v_{ref} [m/s]	28,3	32,7

Bibliography

- [1] ISO 4306 (all parts), *Cranes — Vocabulary*
- [2] ISO 20332; *Cranes — Proof of competence of steel structures*

British Standards Institution (BSI)

BSI is the national body responsible for preparing British Standards and other standards-related publications, information and services.

BSI is incorporated by Royal Charter. British Standards and other standardization products are published by BSI Standards Limited.

About us

We bring together business, industry, government, consumers, innovators and others to shape their combined experience and expertise into standards-based solutions.

The knowledge embodied in our standards has been carefully assembled in a dependable format and refined through our open consultation process. Organizations of all sizes and across all sectors choose standards to help them achieve their goals.

Information on standards

We can provide you with the knowledge that your organization needs to succeed. Find out more about British Standards by visiting our website at bsigroup.com/standards or contacting our Customer Services team or Knowledge Centre.

Buying standards

You can buy and download PDF versions of BSI publications, including British and adopted European and international standards, through our website at bsigroup.com/shop, where hard copies can also be purchased.

If you need international and foreign standards from other Standards Development Organizations, hard copies can be ordered from our Customer Services team.

Copyright in BSI publications

All the content in BSI publications, including British Standards, is the property of and copyrighted by BSI or some person or entity that owns copyright in the information used (such as the international standardization bodies) and has formally licensed such information to BSI for commercial publication and use.

Save for the provisions below, you may not transfer, share or disseminate any portion of the standard to any other person. You may not adapt, distribute, commercially exploit, or publicly display the standard or any portion thereof in any manner whatsoever without BSI's prior written consent.

Storing and using standards

Standards purchased in soft copy format:

- A British Standard purchased in soft copy format is licensed to a sole named user for personal or internal company use only.
- The standard may be stored on more than 1 device provided that it is accessible by the sole named user only and that only 1 copy is accessed at any one time.
- A single paper copy may be printed for personal or internal company use only.

Standards purchased in hard copy format:

- A British Standard purchased in hard copy format is for personal or internal company use only.
- It may not be further reproduced – in any format – to create an additional copy. This includes scanning of the document.

If you need more than 1 copy of the document, or if you wish to share the document on an internal network, you can save money by choosing a subscription product (see 'Subscriptions').

Reproducing extracts

For permission to reproduce content from BSI publications contact the BSI Copyright & Licensing team.

Subscriptions

Our range of subscription services are designed to make using standards easier for you. For further information on our subscription products go to bsigroup.com/subscriptions.

With **British Standards Online (BSOL)** you'll have instant access to over 55,000 British and adopted European and international standards from your desktop. It's available 24/7 and is refreshed daily so you'll always be up to date.

You can keep in touch with standards developments and receive substantial discounts on the purchase price of standards, both in single copy and subscription format, by becoming a **BSI Subscribing Member**.

PLUS is an updating service exclusive to BSI Subscribing Members. You will automatically receive the latest hard copy of your standards when they're revised or replaced.

To find out more about becoming a BSI Subscribing Member and the benefits of membership, please visit bsigroup.com/shop.

With a **Multi-User Network Licence (MUNL)** you are able to host standards publications on your intranet. Licences can cover as few or as many users as you wish. With updates supplied as soon as they're available, you can be sure your documentation is current. For further information, email subscriptions@bsigroup.com.

Revisions

Our British Standards and other publications are updated by amendment or revision.

We continually improve the quality of our products and services to benefit your business. If you find an inaccuracy or ambiguity within a British Standard or other BSI publication please inform the Knowledge Centre.

Useful Contacts

Customer Services

Tel: +44 345 086 9001

Email (orders): orders@bsigroup.com

Email (enquiries): cservices@bsigroup.com

Subscriptions

Tel: +44 345 086 9001

Email: subscriptions@bsigroup.com

Knowledge Centre

Tel: +44 20 8996 7004

Email: knowledgecentre@bsigroup.com

Copyright & Licensing

Tel: +44 20 8996 7070

Email: copyright@bsigroup.com

BSI Group Headquarters

389 Chiswick High Road London W4 4AL UK