

BS ISO 4202:2016



BSI Standards Publication

Reduction sleeves with external 7/24 taper for tools with Morse taper shanks

National foreword

This British Standard is the UK implementation of ISO 4202:2016. It supersedes BS 1660-6:1988 which is withdrawn.

The UK participation in its preparation was entrusted to Technical Committee MTE/18, Tools tips and inserts for cutting applications.

A list of organizations represented on this committee can be obtained on request to its secretary.

This publication does not purport to include all the necessary provisions of a contract. Users are responsible for its correct application.

© The British Standards Institution 2016.
Published by BSI Standards Limited 2016

ISBN 978 0 580 83634 3

ICS 25.060.20

Compliance with a British Standard cannot confer immunity from legal obligations.

This British Standard was published under the authority of the Standards Policy and Strategy Committee on 30 November 2016.

Amendments/Corrigenda issued since publication

| Date | Text affected |
|------|---------------|
|------|---------------|

INTERNATIONAL
STANDARD

BS ISO 4202:2016

ISO
4202

Third edition
2016-11-01

**Reduction sleeves with external 7/24
taper for tools with Morse taper shanks**

*Douilles de réduction au cône extérieur 7/24 pour outils à queue
cône Morse*



Reference number
ISO 4202:2016(E)

© ISO 2016



COPYRIGHT PROTECTED DOCUMENT

© ISO 2016, Published in Switzerland

All rights reserved. Unless otherwise specified, no part of this publication may be reproduced or utilized otherwise in any form or by any means, electronic or mechanical, including photocopying, or posting on the internet or an intranet, without prior written permission. Permission can be requested from either ISO at the address below or ISO's member body in the country of the requester.

ISO copyright office
Ch. de Blandonnet 8 • CP 401
CH-1214 Vernier, Geneva, Switzerland
Tel. +41 22 749 01 11
Fax +41 22 749 09 47
copyright@iso.org
www.iso.org

Contents

| | Page |
|---|----------|
| Foreword | iv |
| 1 Scope | 1 |
| 2 Normative references | 1 |
| 3 Terms and definitions | 1 |
| 4 Dimensions | 2 |
| Annex A (informative) Relationship between designations in this document and ISO 13399 (all parts) | 3 |
| Bibliography | 4 |

Foreword

ISO (the International Organization for Standardization) is a worldwide federation of national standards bodies (ISO member bodies). The work of preparing International Standards is normally carried out through ISO technical committees. Each member body interested in a subject for which a technical committee has been established has the right to be represented on that committee. International organizations, governmental and non-governmental, in liaison with ISO, also take part in the work. ISO collaborates closely with the International Electrotechnical Commission (IEC) on all matters of electrotechnical standardization.

The procedures used to develop this document and those intended for its further maintenance are described in the ISO/IEC Directives, Part 1. In particular the different approval criteria needed for the different types of ISO documents should be noted. This document was drafted in accordance with the editorial rules of the ISO/IEC Directives, Part 2 (see www.iso.org/directives).

Attention is drawn to the possibility that some of the elements of this document may be the subject of patent rights. ISO shall not be held responsible for identifying any or all such patent rights. Details of any patent rights identified during the development of the document will be in the Introduction and/or on the ISO list of patent declarations received (see www.iso.org/patents).

Any trade name used in this document is information given for the convenience of users and does not constitute an endorsement.

For an explanation on the meaning of ISO specific terms and expressions related to conformity assessment, as well as information about ISO's adherence to the World Trade Organization (WTO) principles in the Technical Barriers to Trade (TBT) see the following URL: www.iso.org/iso/foreword.html.

The committee responsible for this document is ISO/TC 29, *Small tools*, Subcommittee SC 2, *Holding tools, adaptive items and interfaces*.

This third edition cancels and replaces the second edition (ISO 4202:1978), of which it constitutes a minor revision, notably with the addition of [Annex A](#), which gives the relationship between the designations of this document and the ISO 13399 series.

Reduction sleeves with external 7/24 taper for tools with Morse taper shanks

1 Scope

This document specifies the dimensions of reduction sleeves with external 7/24 taper (Nos. 30, 40, 45, 50 and 60) for tools with Morse taper shanks (Nos. 1 to 6).

All these sleeves allow driving of tools having Morse taper shanks which have a tenon at the small end of the shank; some sleeves allow driving of tools having Morse taper shanks which have an axially tapped hole in the shank:

- with the use of an incorporated screw for sleeves 30 × 1 – 40 × 1 – 40 × 2 – 45 × 1 – 45 × 2 – 45 × 3 – 50 × 2 – 50 × 3 – 50 × 4 – 60 × 3 – 60 × 4 – 60 × 5;
- with the use of a draw bar for sleeves 30 × 1 – 30 × 2 – 40 × 1 – 40 × 2 – 40 × 3 – 45 × 1 – 45 × 2 – 45 × 3 – 45 × 4 – 50 × 2 – 50 × 3 – 50 × 4 – 50 × 5 – 60 × 3 – 60 × 4 – 60 × 5 – 60 × 6.

Morse tapers conform to ISO 296 while 7/24 tapers are in accordance with ISO 297.

2 Normative references

The following documents are referred to in the text in such a way that some or all of their content constitutes requirements of this document. For dated references, only the edition cited applies. For undated references, the latest edition of the referenced document (including any amendments) applies.

ISO 296, *Machine tools — Self-holding tapers for tool shanks*

ISO 297, *7/24 tapers for tool shanks for manual changing*

3 Terms and definitions

No terms and definitions are listed in this document.

ISO and IEC maintain terminological databases for use in standardization at the following addresses:

- IEC Electropedia: available at <http://www.electropedia.org/>
- ISO Online browsing platform: available at <http://www.iso.org/obp>

4 Dimensions

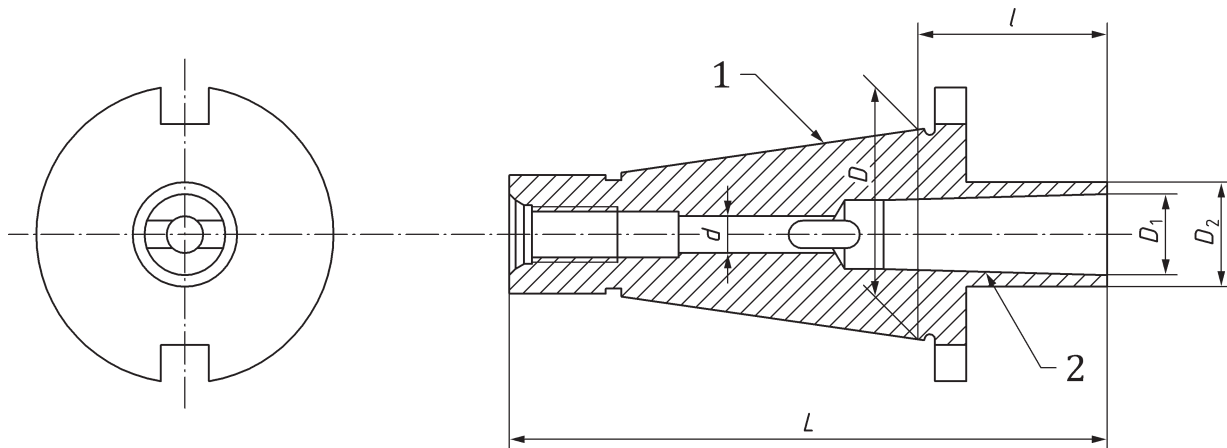

Key

- 1 7/24 external taper
- 2 internal Morse taper

NOTE The sketch is diagrammatic and is not intended to show design details.

Figure 1

Table 1

Dimensions in millimetres

| Designation | | <i>D</i> | <i>D</i> ₁ | <i>D</i> ₂ | <i>d</i> | <i>l</i> max. | <i>L</i> max. |
|---------------------|----------------------|----------|-----------------------|-----------------------|----------|------------------|------------------|
| 7/24 external taper | Internal Morse taper | | | | | | |
| 30 | 1 | 31,750 | 12,065 | 25 | 6,2 | 50 | 118 |
| | 2 | | 17,780 | 32 | 10,3 | 50 | 118 |
| | 3 | | 23,825 | 40 | 12,5 | 70 | 138 |
| 40 | 1 | 44,450 | 12,065 | 25 | 6,2 | 50 | 143 |
| | 2 | | 17,780 | 32 | 10,3 | 50 | 143 |
| | 3 | | 23,825 | 40 | 12,5 | 65 | 158 |
| | 4 | | 31,267 | 48 | 17,0 | 95 | 188 |
| 45 | 1 | 57,150 | 12,065 | 25 | 6,2 | 50 | 157 |
| | 2 | | 17,780 | 32 | 10,3 | 50 | 157 |
| | 3 | | 23,825 | 40 | 12,5 | 65 | 172 |
| | 4 | | 31,267 | 48 | 17,0 | 75 | 182 |
| | 5 | | 44,399 | 63 | 21,0 | 125 | 232 |
| 50 | 2 | 69,850 | 17,780 | 32 | 10,3 | 60 | 187 |
| | 3 | | 23,825 | 40 | 12,5 | 65 | 192 |
| | 4 | | 31,267 | 48 | 17,0 | 70 | 197 |
| | 5 | | 44,399 | 63 | 21,0 | 105 | 232 |
| 60 | 3 | 107,950 | 23,825 | 40 | 12,5 | 70 | 277 |
| | 4 | | 31,267 | 48 | 17,0 | 70 | 277 |
| | 5 | | 44,399 | 63 | 21,0 | 70 | 277 |
| | 6 | | 63,348 | 80 | 25,0 | 100 | 307 |

Annex A (informative)

Relationship between designations in this document and ISO 13399 (all parts)

For relationship between designations in this document and preferred symbols according to ISO 13399 (all parts), see [Table A.1](#).

**Table A.1 — Relationship between designations in this document
and ISO 13399 (all parts)**

| Symbol in this document | Reference in this document | Property name in ISO 13399 (all parts) | Symbol in ISO 13399 (all parts) | Reference in ISO 13399 (all parts) |
|----------------------------|---|--|---------------------------------------|--|
| 7/24 external taper | Figure 1 Table 1 | connection size code machine side | CZCMS | 71EBDBF5060E6 |
| Internal Morse taper | Figure 1 Table 1 | connection size code workpiece side | CZCWS | 727C2BCBC1684 |
| <i>l</i> | Figure 1 | protruding length | LPR | 71DCD394BB20E |
| <i>L</i> | Figure 1 | overall length | OAL | 71D078EB7C086 |
| <i>l</i> max. | Table 1 | protruding length | LPR | 71DCD394BB20E |
| <i>L</i> max. | Table 1 | overall length | OAL | 71D078EB7C086 |

Bibliography

- [1] ISO 2583,¹⁾ *Tool shanks and equipment with 7/24 tapers — Collar dimensions*
- [2] ISO 13399 (all parts), *Cutting tool data representation and exchange*

1) Withdrawn.

British Standards Institution (BSI)

BSI is the national body responsible for preparing British Standards and other standards-related publications, information and services.

BSI is incorporated by Royal Charter. British Standards and other standardization products are published by BSI Standards Limited.

About us

We bring together business, industry, government, consumers, innovators and others to shape their combined experience and expertise into standards-based solutions.

The knowledge embodied in our standards has been carefully assembled in a dependable format and refined through our open consultation process. Organizations of all sizes and across all sectors choose standards to help them achieve their goals.

Information on standards

We can provide you with the knowledge that your organization needs to succeed. Find out more about British Standards by visiting our website at bsigroup.com/standards or contacting our Customer Services team or Knowledge Centre.

Buying standards

You can buy and download PDF versions of BSI publications, including British and adopted European and international standards, through our website at bsigroup.com/shop, where hard copies can also be purchased.

If you need international and foreign standards from other Standards Development Organizations, hard copies can be ordered from our Customer Services team.

Copyright in BSI publications

All the content in BSI publications, including British Standards, is the property of and copyrighted by BSI or some person or entity that owns copyright in the information used (such as the international standardization bodies) and has formally licensed such information to BSI for commercial publication and use.

Save for the provisions below, you may not transfer, share or disseminate any portion of the standard to any other person. You may not adapt, distribute, commercially exploit, or publicly display the standard or any portion thereof in any manner whatsoever without BSI's prior written consent.

Storing and using standards

Standards purchased in soft copy format:

- A British Standard purchased in soft copy format is licensed to a sole named user for personal or internal company use only.
- The standard may be stored on more than 1 device provided that it is accessible by the sole named user only and that only 1 copy is accessed at any one time.
- A single paper copy may be printed for personal or internal company use only.

Standards purchased in hard copy format:

- A British Standard purchased in hard copy format is for personal or internal company use only.
- It may not be further reproduced – in any format – to create an additional copy. This includes scanning of the document.

If you need more than 1 copy of the document, or if you wish to share the document on an internal network, you can save money by choosing a subscription product (see 'Subscriptions').

Reproducing extracts

For permission to reproduce content from BSI publications contact the BSI Copyright & Licensing team.

Subscriptions

Our range of subscription services are designed to make using standards easier for you. For further information on our subscription products go to bsigroup.com/subscriptions.

With **British Standards Online (BSOL)** you'll have instant access to over 55,000 British and adopted European and international standards from your desktop. It's available 24/7 and is refreshed daily so you'll always be up to date.

You can keep in touch with standards developments and receive substantial discounts on the purchase price of standards, both in single copy and subscription format, by becoming a **BSI Subscribing Member**.

PLUS is an updating service exclusive to BSI Subscribing Members. You will automatically receive the latest hard copy of your standards when they're revised or replaced.

To find out more about becoming a BSI Subscribing Member and the benefits of membership, please visit bsigroup.com/shop.

With a **Multi-User Network Licence (MUNL)** you are able to host standards publications on your intranet. Licences can cover as few or as many users as you wish. With updates supplied as soon as they're available, you can be sure your documentation is current. For further information, email subscriptions@bsigroup.com.

Revisions

Our British Standards and other publications are updated by amendment or revision.

We continually improve the quality of our products and services to benefit your business. If you find an inaccuracy or ambiguity within a British Standard or other BSI publication please inform the Knowledge Centre.

Useful Contacts

Customer Services

Tel: +44 345 086 9001

Email (orders): orders@bsigroup.com

Email (enquiries): cservices@bsigroup.com

Subscriptions

Tel: +44 345 086 9001

Email: subscriptions@bsigroup.com

Knowledge Centre

Tel: +44 20 8996 7004

Email: knowledgecentre@bsigroup.com

Copyright & Licensing

Tel: +44 20 8996 7070

Email: copyright@bsigroup.com

BSI Group Headquarters

389 Chiswick High Road London W4 4AL UK