

Lift (Elevator) installation —

Part 5: Control devices, signals and additional fittings

ICS 91.140.90

National foreword

This British Standard was published by BSI. It is the UK implementation of ISO 4190-5:2006.

The UK participation in its preparation was entrusted to Technical Committee MHE/4, Lifts, hoists and escalators.

A list of organizations represented on MHE/4 can be obtained on request to its secretary.

This publication does not purport to include all the necessary provisions of a contract. Users are responsible for its correct application.

Compliance with a British Standard cannot confer immunity from legal obligations.

This British Standard was published under the authority of the Standards Policy and Strategy Committee on 30 November 2006

© BSI 2006

ISBN 0 580 49701 1

Amendments issued since publication

| Amd. No. | Date | Comments |
|----------|------|----------|
| | | |
| | | |
| | | |
| | | |

INTERNATIONAL STANDARD

ISO 4190-5

Third edition
2006-11-01

Lift (Elevator) installation —

Part 5:

Control devices, signals and additional fittings

Installation d'ascenseurs —

Partie 5: Dispositifs de commande et de signalisation et accessoires complémentaires



Reference number
ISO 4190-5:2006(E)

Contents

Page

| | |
|--|-----------|
| Foreword | iv |
| Introduction | v |
| 1 Scope | 1 |
| 2 Normative references | 1 |
| 3 Specifications relating to controls | 2 |
| 4 Handrail | 8 |
| Annex A (normative) Special systems | 9 |
| Annex B (informative) Particular requirements | 14 |
| Annex C (normative) Representative symbols | 17 |
| Bibliography | 19 |

Foreword

ISO (the International Organization for Standardization) is a worldwide federation of national standards bodies (ISO member bodies). The work of preparing International Standards is normally carried out through ISO technical committees. Each member body interested in a subject for which a technical committee has been established has the right to be represented on that committee. International organizations, governmental and non-governmental, in liaison with ISO, also take part in the work. ISO collaborates closely with the International Electrotechnical Commission (IEC) on all matters of electrotechnical standardization.

International Standards are drafted in accordance with the rules given in the ISO/IEC Directives, Part 2.

The main task of technical committees is to prepare International Standards. Draft International Standards adopted by the technical committees are circulated to the member bodies for voting. Publication as an International Standard requires approval by at least 75 % of the member bodies casting a vote.

Attention is drawn to the possibility that some of the elements of this document may be the subject of patent rights. ISO shall not be held responsible for identifying any or all such patent rights.

ISO 4190-5 was prepared by Technical Committee ISO/TC 178, *Lifts, escalators and moving walks*.

This third edition cancels and replaces the second edition (ISO 4190-5:1987), which has been technically revised.

ISO 4190 consists of the following parts, under the general title *Lift (Elevator) installation*¹⁾:

- *Part 1: Class I, II, III and VI lifts*
- *Part 2: Class IV lifts*
- *Part 3: Service lifts class V*
- *Part 5: Control devices, signals and additional fittings*
- *Part 6: Passenger lifts to be installed in residential buildings — Planning and selection*

1) The title, which differs in various respects in the other, previously published, parts, is to form the subject of a Technical Corrigendum for each of the parts concerned.

Introduction

This third edition of ISO 4190-5 takes into account the latest studies concerning ergonomics and the needs of various people with disabilities.

Many regional disabled people's associations were associated with this work and were in agreement with these new concepts. A general consensus had been obtained on the data recorded in this part of ISO 4190.

However, due to existing regulations and, in particular, local habits, in some countries it could be difficult to introduce a part of these specifications without certain precautions being taken (for example, modification of a well-known symbol).

Concerning provisions expressed in terms of values (dimensions, sound level, etc.), this part of ISO 4190 often gives two ranges of values: a general range, followed by a recommended range. The range of recommended values is intended as the target to be reached, as far as is possible, in each country.

Lift (Elevator) installation —

Part 5: Control devices, signals and additional fittings

1 Scope

This part of ISO 4190 specifies the control devices, buttons and indicators to be provided when a lift (US: elevator) is constructed and installed, taking into account the type of control intended for the lift and also ensuring the ease of access for disabled persons (motor and/or sensory). Annex B gives particular requirements for access. The description of the controls is given only in order to define the buttons and indicators. It does not constitute a complete description of these controls nor does it attempt to standardize them.

This part of ISO 4190 also specifies the requirements for handrails when provided in the car.

It is applicable to lifts of classes I to IV and VI as defined in ISO 4190-1 and ISO 4190-2.

Group collective lifts have common controls and are electrically interconnected so as to provide a better service and for reasons of economy. The system can be more or less complex according to the number of lifts and the expected traffic. Consequently, this part of ISO 4190 does not deal with supplementary signals which the manufacturer may consider useful (e.g. “next car”, “stand clear of the doors”).

The following are not dealt with in this part of ISO 4190:

- a) special features (and their corresponding signals), such as certain features for improving the service of bed lifts, touch screens or voice activators;
- b) any devices for speeding the traffic in the case of automatic doors (variable time delays according to different criteria, closing button, light ray, etc.).

The requirements of this part of ISO 4190 are intended to be followed in all cases where the controls and the basic signals are concerned, and can also be used as a guide in developing supplementary signals.

2 Normative references

The following referenced documents are indispensable for the application of this document. For dated references, only the edition cited applies. For undated references, the latest edition of the referenced document (including any amendments) applies.

ISO 4190-1, *Lift (Elevator) installation — Part 1: Class I, II, III and VI lifts*

ISO 4190-2, *Lift (Elevator) installation — Part 2: Class IV lifts*

3 Specifications relating to controls

3.1 Types of control systems

3.1.1 Down collective control (DC)

With the down collective control (DC), landing calls can be registered whether or not the car is available.

The calls are registered by pressing the call button provided on each landing. If the car is free or coming down, it will answer the landing call from the highest landing and then the other calls in succession as it approaches the main floor.

The calls registered in the car will be retained at any time and answered in logical sequence according to the direction of travel.

This control can be used when there is no passenger traffic between upper floors — passengers make use of the lift from the main floor to the required floor or vice versa — and when there is no level served below the main floor. It requires one call button per landing. It can be used with a single or group collective lift (see Clause 1) and where one or more levels below the main floor level are to be served.

The control shall be DC for the levels above the main floor, but *up collective* for the levels below the main floor.

The precise name for this type of control is *up-distributive/down-collective*.

3.1.2 Directional (full) collective control (FC)

This control requires two call buttons on each intermediate landing — one for ascent and another for descent — so that the passengers can indicate the direction in which they wish to travel, with a single button at the terminal landings.

Both landing and car calls registered are answered in logical sequence according to the direction of travel of the car.

This system is installed when inter-floor traffic is expected during upward and downward travel. It can be used with a single lift or in group collective lifts (see Clause 1).

3.1.3 Destination-oriented lift systems (DO)

For destination controls, see Annex A.

3.1.4 Lift group

A lift group is formed of lifts having the management of landing calls in common.

Group operation can be provided for DC, FC or DO controls.

For destination controls using a keypad, see Annex A.

3.1.5 Car call sequential step scanning

Lift car call sequential step scanning shall be provided where car control buttons are provided more than 1 220 mm above the car floor.

Floor selection shall be accomplished by applying momentary or constant pressure to one of the two special buttons (up and down scan button).

— The up scan button shall sequentially select floors above the current floor.

— The down scan button shall sequentially select floors below the current floor.

When pressure is removed from the up or down scan button for more than 2 s, the last floor selected shall be registered as a car call.

The up and down scan button shall be located adjacent to, or immediately above, the emergency control buttons.

3.2 Control devices

3.2.1 On landings

3.2.1.1 Down collective control

Each landing station shall be provided with one call button (no marking required).

If the lift serves floors above and below the main floor, the main floor shall be provided with two call buttons marked with the symbols ▼ and ▲ (see Table C.1, 6).

3.2.1.2 Directional full collective control in the two directions of operation

At each intermediate floor, the landing station shall be provided with two call buttons, one marked with symbol ▲ and the other with symbol ▼ (see Table C.1, 6).

At each terminal landing, the landing station shall be provided with one call button, marked with symbol ▲ or ▼, as appropriate.

For all types of control, if a special device is used to improve accessibility, the international symbol of accessibility shall be used (see Table C.1, 10).

3.2.1.3 Lift group

Every floor shall be equipped with landing stations having one or two call buttons. The minimum quantity of landing stations shall be

- one per face for lifts facing on another (opposite lift),
- one for a maximum of four adjacent lifts (if the landing station is located between two lifts).

Lift groups containing only one wheelchair-accessible lift shall be equipped with a special button marked with the wheelchair symbol, used to call the wheelchair-accessible lift (see Table C.1, 10).

This lift shall be identified by the standard symbol of accessibility (see Table C.1, 10).

3.2.1.4 Buttons (not applicable to keypads, see Annex A)

The following is applicable to landing buttons other than those on keypads.

- a) For call registration, the necessary operating force on the active part of the button shall be not less than 1 N and not more than 5 N, with an operating force of between 2,5 N and 5 N recommended.
- b) The dimension of the active part shall be as follows:
 - the minimum area shall be not less than 280 mm², with a minimum area of not less than 490 mm² recommended;

- the minimum dimensions shall allow the inscribing of a circle with a diameter not less than 19 mm, with a minimum diameter of 20 mm recommended.

In the case of two buttons, the vertical gap between the active parts shall be not less than 10 mm. The buttons shall be arranged one above the other, with the ▲ button at the top.

- c) The call registration shall be visible and audible, adjustable between 35 dB(A) and 80 dB(A), with a recommended maximum of 65 dB(A). In addition, it is permitted to provide a mechanical operating feedback of call registration. The audible signal shall be given on every individual operation of the button even if the call is already registered. It shall be different from other audible signals (e.g. hall lanterns) and have its origin located close to the button.
- d) The height from the floor to the centre line of any button shall be between 890 mm and 1 220 mm, with a height of between 900 mm and 1 100 mm recommended.
- e) The active part of the button shall be identifiable both visually and by touch from the faceplate.
- f) The faceplate of a landing push button shall be in contrast to its surrounding background.
- g) For passenger lifts accessible to wheelchair users, the minimal dimension to the vertical axis of the button from any corner, shall be minimum 500 mm.
- h) If markings exist, the size of any symbol shall be 15 mm at the minimum and 40 mm at the maximum, and they shall be in raised relief, have a thickness not less than 0,8 mm, and be contrasted to their background.

Symbol(s) shall be in either of the two following positions:

- preferably, on the active part of the button;
- on the left of the active part of the button at a distance between 10 mm and 15 mm.

3.2.2 In the car

3.2.2.1 Operating panel (not applicable to keypads, see Annex A)

The operating panel(s) shall be provided with the following:

- one button for each floor (marked -2, -1, 0, 1, 2, etc.);
- one alarm button, yellow in colour and with a bell-shaped symbol, or one button with a yellow bell-shaped symbol (see Table C.1, 1) or a HELP button marked with a phone symbol (see Table C.1, 4), with the alarm button being recommended;
- one door “re-opening” button (for automatic doors) marked with the symbol ◀▶ (see Table C.1, 2);
- one stopping device (if required by the safety standards in force), red and with the word “STOP” (see Table C.1, 12);
- if required, one door “closing” button (for automatic doors) marked with the symbol ▶◀ (see Table C.1, 3).

3.2.2.2 Buttons (not applicable to keypads, see Annex A)

The following is applicable to in-car buttons other than those on keypads.

- a) The requirements of 3.2.1.4, a), the first sentence only of b), and c) and e) shall apply;

- b) The minimum gap between two active parts of two floor buttons shall be not less than 10 mm;
- c) The centre line of alarm and door “re-open” buttons shall be located from the floor at $900 \text{ mm} \pm 10 \text{ mm}$;
- d) The lowest floor button shall be located above the alarm and “re-open” door button. The vertical gap between alarm, door “re-open” and call buttons shall be not less than twice the distance defined at b).
- e) The highest floor button shall be located at maximum 1 220 mm above the floor. If possible, the upper limit shall be no more than 1 100 mm (by using lift car call sequential step scanning it is permitted to provide floor buttons above 1 220 mm);
- f) The size of any symbol shall be 15 mm at the minimum and 40 mm at the maximum. It shall be in raised relief, have a thickness not less than 0,8 mm and be contrasted to its surrounding background.

Symbols shall be in either of the two following positions:

- preferably, on the active part of the button;
 - on the left of the active part of the button, at a distance between 10 mm and 15 mm.
- g) Exit button (main floor), whose identification shall be provided by either
 - a raised relief star on or beside the button at a distance from 10 mm to 15 mm from the button (see Table C.1, 11), or
 - a green button, raised $5 \text{ mm} \pm 1 \text{ mm}$ above the other buttons, in which case the floor shall be marked.
 - h) The order of call buttons shall be
 - for a horizontal single row, from left to right,
 - for a vertical single column, from the bottom to the top, and
 - for multiple rows, from left to right and from the bottom to top.

3.2.2.3 Location of car operating panel

3.2.2.3.1 Passenger lift with nominal load < 450 kg

The panel shall be located on the side wall:

- a) for a centre-opening door, on the right-hand side when entering the car;
- b) for a side-opening door, on the closing side.

3.2.2.3.2 Passenger lift with nominal load $\geq 450 \text{ kg}$

The panel shall be located:

- a) for a centre-opening door, on the right-hand side when entering the car;
- b) for a side-opening door, on the closing side;
- c) on the front wall.

For passenger lifts accessible to wheelchair users, the minimal dimension to the vertical axis of the button from any corner of the car shall be 400 mm.

3.2.2.3.3 Special case for two car entrances

The specifications of 3.2.2.3.1 and 3.2.2.3.2 shall apply for both car entrances.

3.2.2.3.4 Additional car operating panel

A second car operating panel may be added in accordance with 3.2.2.2 a), b), g) and h).

3.3 Indicators

3.3.1 On landings

3.3.1.1 Destination-oriented lift systems

For requirements applicable to destination-oriented lift systems, see Annex A.

3.3.1.2 Types of indicators

Two illuminated indicator arrows giving advanced information on the next departure direction of the car (only one at the terminal landings) shall be placed above or near the doors in a visible position to indicate the direction in which the car will subsequently move.

An audible signal shall accompany the lighting of the arrow.

In the case of a single lift, these requirements can be satisfied by a device in the car visible and audible from the landing.

For a manually operated landing door, an illuminated and audible signal shall inform waiting users that the car is at the floor or is about to stop. The illuminated signal may be assured by one or more transparent vision panels so that the waiting users can see that the car is at the floor (car permanently illuminated). The audible signal need not be given if a landing call is not registered.

3.3.1.3 Indicator requirements

3.3.1.3.1 Audible signals shall have a sound level between 35 dB(A) and 80 dB(A), with a recommended maximum of 65 dB(A), adjustable to the site conditions. The means of the adjustment shall not be accessible to users.

3.3.1.3.2 Different audible signals shall be used to indicate *up* and *down* in the case of down collective and directional collective in the two directions:

- a single sound for *up*;
- two sounds for *down*.

3.3.1.3.3 When landing indicator arrows are used, they shall be located between 1,80 m and 2,50 m above the floor with an angle of vision $140^\circ \pm 10^\circ$.

The minimum height of the arrows shall be 40 mm.

3.3.2 In the car

3.3.2.1 General

The following shall be provided:

- a visible (illuminated) and audible position indicator;
- an alarm device or an interphone, telephone or similar device (if required by the national regulation in force).

With collective control systems there shall be an illuminated indicator to show that the car calls have been registered.

3.3.2.2 Indicator requirements

3.3.2.2.1 The illuminated signal shall be located above the car-operating panel, and the centre of the indicator shall be positioned between 1,6 m and 1,8 m from the car floor.

The height of the floor number shall be a minimum of 13 mm, with a minimum height of 30 mm recommended, and a maximum of 60 mm, and the indicator shall be of a colour contrasting with its surrounding background.

3.3.2.2.2 A second indicator, if required, may be placed above the car door, or on a second car-operating panel.

As an alternative, the indicator in the car-operating panel may be moved to below 1,6 m if an additional indicator is provided at a high level (e.g. above the door).

3.3.2.2.3 When the car stops, a voice shall indicate in the local language(s) the car position. The audible signals shall have a sound level between 35 dB(A) and 80 dB(A), with the recommended maximum being 65 dB(A), adjustable to suit the site conditions.

For the lift with a maximum of six stops and a maximum speed of 1 m/s, as an alternative, voice announcements may be replaced by sounds as the car passes or stops at a floor served by the lift; however, this is less convenient.

3.3.2.2.4 The car shall have one alarm device (two-way communication system) permanently connected to a safety organization according to the following.

- The device shall ensure voice communication in both directions with an organization in charge of passenger rescue or the person in charge of the safety of the building.

NOTE As an aid to communication, an induction loop can assist people with impaired hearing. In this case, the availability of the induction loop is shown in the car by the symbol "induction loop" — audio frequency induction loop system (AFILS). See Table C.1, 9.

- A permanent operating force shall not be necessary to send the alarm.
- The device shall provide visual and audible information feedback for passengers confirming
 - 1) alarm sent, using a "bell" symbol (see Table C.1, 1), and
 - 2) alarm received, voice communication established, using the "communication established" symbol (see Table C.1, 8).

3.3.3 Optional indicators

On the landings, an illuminated "out of use" signal of minimum diameter 25 mm (see Table C.1, 5) and in the car an illuminated "overload" signal (see Table C.1, 7) may be provided.

4 Handrail

At least one handrail shall be provided in the car and shall be fixed horizontally on the same side as the car-operating panel.

The gripping part of the handrail shall

- be in a perimeter of between 100 mm and 160 mm,
- have a minimum dimension of 25 mm,
- a maximum dimension 55 mm, and
- have no sharp edges.

The handrail shall be fixed at a height from the floor of between 800 mm and 950 mm, with a height of 900 mm \pm 25 mm recommended.

The free space between the wall and the gripping part shall be between 35 mm and 45 mm.

Annex A (normative)

Special systems

A.1 General

If a lift is in a location where the user can be instructed in the method of use, e.g. in an office building, a special system may be provided:

- a) the keypad system;
- b) the destination-oriented lift system.

This annex gives the requirements applicable only to these systems, replacing or additional to those given in 3.2.1.4, 3.2.2.1 and 3.2.2.2, and 3.3.1, except where noted.

A.2 Keypad systems

A.2.1 General

The following replace the requirements given in 3.2.1.4.

- a) The arrangement of the numbered keys shall be according to the standard telephone type, see Figure A.1.
- b) The operating force for the button shall be not less than 1 N and not more than 5 N, with an operating force of not less than 2,5 N and not more than 5 N recommended.
- c) The minimum dimension of the active part shall be as follows:
 - a minimum area of not less than 280 mm², with a minimum area of not less than 490 mm² recommended;
 - the minimum dimension of the active part of the button shall allow the inscribing of a circle with a diameter not less than 19 mm, with a minimum dimension of 20 mm recommended.

The vertical and horizontal distance between the active parts shall be not less than 10 mm. For inclined keypads the distance may be reduced to 5 mm.

- d) The user shall be able to know that the button has been operated by perceivable movement of the button and an audible signal that shall be given on every individual operation of a button. The call registration shall be confirmed by a visible and verbal signal, adjustable between 35 dB(A) and 80 dB(A), with a maximum of 65 dB(A) recommended, even if the call is already registered.
- e) The height from floor level to the centre line of any button shall be between 890 mm and 1 220 mm, with a height of between 900 mm and 1 100 mm recommended.
- f) The active part of the button shall be easily identifiable visually and by touch.
- g) The face plate of a keypad shall be in contrast to its surrounding background.

- h) For passenger lifts accessible to wheelchair users, the buttons shall be accessible by parallel approach of the wheelchair travel. The recommended distance to the centre line of any of the buttons from any wall or door at right angles is 500 mm minimum.
- i) The height of the symbol shall be a minimum of 13 mm, with a height of 15 mm recommended, a maximum 40 mm, and shall be contrasted to the background.
- j) The number 5 key shall have a single raised dot. The dot shall have a base diameter of $3^{+0,5}_0$ mm and a dot height of between 0,6 mm and 0,9 mm.
- k) Any additional symbol shall be in raised relief with a thickness of not less than 0,8 mm and contrasted to its surrounding background.
- l) Numbers and symbols shall be on the active part of the button.
- m) The button for the exit floor (lowest row, left column) shall be a green button raised above the other buttons $5\text{ mm} \pm 1$ or marked with a raised relief star (see Table C.1, 11).

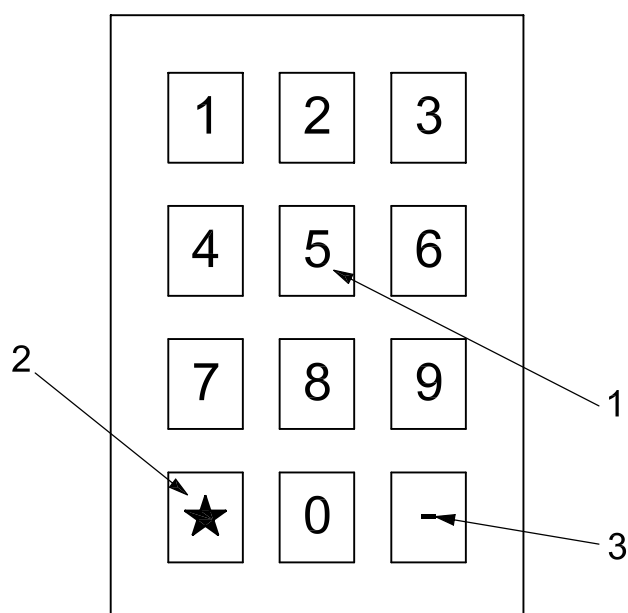

Key



- 1 dot
- 2 green button raised above the other buttons $5\text{ mm} \pm 1$ mm or marked with a raised relief star
- 3 minus sign in raised relief

Figure A.1 — Keypad arrangement

A.2.2 Keypads used in operating panels (replaces 3.2.2.2)

A.2.2.1 When a keypad system is used in the car, the car-operating panel shall include the following:

- keypad;
- one alarm button, yellow in colour and with a bell-shaped symbol, or one button with a yellow bell-shaped symbol (see Table C.1, 1) or a HELP button marked with a phone symbol (see Table C.1, 4), with the alarm button being recommended;

- one door “re-opening” button (for automatic doors) marked with the symbol  (see Table C.1, 2);
- one stopping device (if required by the safety standards in force), red and marked with the word “STOP”, (see Table C.1, 12);
- If required, one door “closing” button (for automatic doors) marked with the symbol  (see Table C.1, 3).

A.2.2.2 Keypads located within the car shall meet the following requirements.

- a) The requirements of A.2.1 a), b), c), d) e), f), g), i), j), k), l) and m) apply.
- b) The centre line of alarm and door open buttons shall be located from the floor at $900 \text{ mm} \pm 10 \text{ mm}$. This also applies to a door-closing button where such a button is provided.
- c) The exit button shall be raised $5 \text{ mm} \pm 1 \text{ mm}$ more than the other buttons and shall preferably be green or marked with a raised relief star (see Table C.1, 11).

A.2.2.3 The keypad, the alarm button and door re-open buttons shall normally be placed on the side wall.

If the car dimensions do not allow a wheelchair user to turn, they shall be located as follows:

- for centre-opening doors, on the right hand side when entering the car;
- for side-opening doors, on the closing side.

However, if the car dimensions *do* allow a wheelchair user to turn, the keypad, the alarm button and door re-open buttons may be placed on the front wall.

Lateral space between the centre line of any buttons to a corner in the car shall be a minimum of 400 mm.

A.3 Destination-oriented lift system

A.3.1 General

This is a lift system that provides landing controls for selecting destination floors, lobby indicators designating which elevator to board, and a car indicator designating the floors at which the car will stop.

A.3.2 On the landing

The device used to register the destination floor shall be in accordance with 3.2.1.4 and 3.2.2.2 g) and h).

With a keypad system, it shall be in accordance with A.2.1.

The location of the registering destination system shall be easily identifiable by all users.

The minimum quantity of devices per floor shall be as follows:

- one per face for lifts facing each other (opposite lifts);
- one for a maximum of four adjacent lifts, if the control device is located between two lifts.

A.3.3 Assigned car device

A.3.3.1 Near device registering destination floor

The selected floor number shall be confirmed with a visible and audible signal, automatically or manually activated.

This indicator shall be close to the registering destination device, the height of the information shall be between 30 mm and 60 mm, and it shall be of a colour contrasting to its surrounding background.

The audible signal shall indicate in the local language(s) the car designation and the direction of the car. The sound level of the information shall be adjustable and adjusted to site conditions, between 35 dB(A) and 80 dB(A), with a maximum of 65 dB(A) recommended.

The audible signal may be activated by pressing the function button identified by the symbol of accessibility (see Table C.1, 10). This symbol shall be in raised relief not less than 0,8 mm or have a tactile indication by means of three raised dots (0,6 mm to 0,9 mm height, diameter 0,8 mm), spaced 6 mm at base diameter, in the form of an equilateral triangle. The function button shall be located immediately below the keypad arrangement or floor buttons.

A.3.3.2 At each landing door level

Visible and audible information shall be provided on each lift of the bank to indicate the car designation and direction of the car.

- The visible information shall be located between 1,80 m and 2,50 m above the floor with an angle of vision $140^\circ \pm 10^\circ$. The height of the information shall be a minimum of 40 mm.
- Audible signals shall have a sound level between 35 dB(A) and 80 dB(A), with a maximum of 65 dB(A) recommended, adjustable to the site conditions. The means of the adjustment shall not be accessible to users. The audible tone and verbal announcement shall be the same as those given at the call button or call button keypad, if provided.

In addition, a tactile and visible lift car and level identification shall be provided on both sides of the landing frame, centred at 1 500 mm above the floor measured from the centre line of the characters.

- The upper character shall give the floor number, with a raised star for the main floor; the lower character, the car identification.
- The characters shall be 50 mm high with raised relief marking, of width $6 \text{ mm} \pm 1 \text{ mm}$ and thickness $1^{+0,5}_0 \text{ mm}$, and shall be contrasted with the background.

See Figure A.2.

NOTE This tactile and visible lift level identification can also be used for lifts according to 3.1.1, 3.1.2 and 3.1.3.

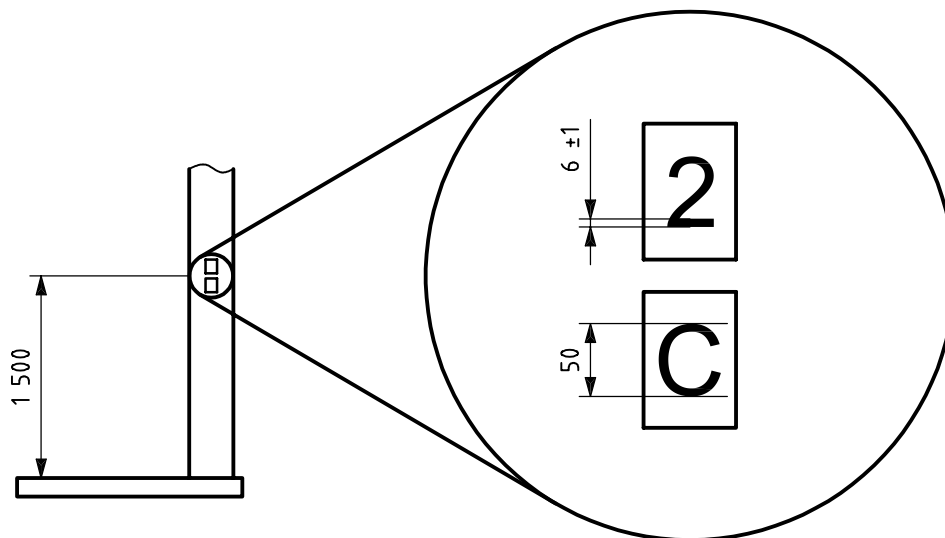

Figure A.2 — Symbol characteristics

A.3.4 In the car

The following shall be provided.

a) Car position indicator (audible and visible):

- The illuminated signal shall be located above the car-operating panel, and the centre of the indicator shall be positioned between 1,60 m and 1,80 m from the car floor,
- The height of the floor number shall be a minimum of 13 mm, with a minimum height of 30 mm recommended, and at a maximum of 60 mm, and the indicator shall be of a colour contrasting with its surrounding background, and
- When the car stops, a voice shall indicate in the local language(s) the car position. The audible signals shall have a sound level between 35 dB(A) and 80 dB(A), with the recommended maximum being 65 dB(A), adjustable to suit the site conditions;

b) One alarm button, yellow in colour and with a bell-shaped symbol, or one button with a yellow bell-shaped symbol (see Table C.1, 1) or a HELP button marked with a phone symbol (see Table C.1, 4), with the alarm button being recommended;

c) One door “re-opening” button (for automatic doors) marked with the symbol ◀▶ (see Table C.1, 2);

d) A display shall be provided in the car with visible indicators to show registered car destination. The visible indication shall extinguish when the car arrives at the designated floor.

A standard five-pointed star (see Table C.1, 11), may be used to indicate the main entry floor.

A special device may be used to initiate the voice announcement when needed.

Annex B (informative)

Particular requirements

B.1 General

These *particular requirements* may be applied to suit special customer needs or to meet national regulations for lifts specifically designed to increase accessibility for persons with disabilities — particularly those in wheelchairs. They are applicable to a nominal load ≥ 630 kg for passenger lifts.

B.2 On landings

The requirements of 3.2.1.4 are replaced by the following requirements.

- a) For call registration, the necessary operating force on the active part of the button shall be a minimum 2,5 N and a maximum of 5 N.
- b) Minimum dimension of the active part: 50 × 50 mm or diameter 50 mm.
- c) The information of call registration shall be visible, audible and adjustable between 35 dB(A) and 65 dB(A). The audible signal shall be given on every individual operation of the button even if the call is already registered. It shall be different than other audible signal (e.g. hall lanterns) and have its origin located close to the button.
- d) The height from the floor of the lowest button shall be 850 mm ± 5 mm and the height from the floor to the highest button shall be 1 000 mm ± 5 mm.
- e) The active part of the button shall be identifiable visually and by touch from the faceplate.
- f) The plate of the landing floor button shall be contrasted to its surrounding background.
- g) For passenger lifts accessible to wheelchair users, the minimum distance to the centre line of the button from any corner shall be 500 mm.

If markings exist, the size of the symbol shall be a minimum of 15 mm in raised relief with a thickness not less than 0,8 mm and contrasted to its surrounding background.

The symbol shall be in one of the two following positions:

- preferably, on the active part of the button;
- on the left of the active part of the button, at a distance between 10 mm and 15 mm, when measured from the edge of the active part of the button to the edge of the raised relief.

B.3 In the car

The requirements of 3.2.2.2 are replaced by the following.

- a) The requirements according to B.2 a), b), c), e) and f) apply.
- b) The axis of the first row of buttons shall be located 850 mm from the floor.
- c) The size of any symbol shall be a minimum of 15 mm, in raised relief with a thickness not less than 0,8 mm, located on the active part of the button.
- d) The distance between adjacent parts of two buttons shall be $10 \text{ mm} \pm 1 \text{ mm}$.
- e) Order and positioning of call buttons (see Figures B.1, B.2 and B.3):

The call buttons shall be laid horizontally on a tilted plate. The projection on the horizontal of the tilted part shall be equal to $100 \text{ mm} \pm 10$.

- In the case of a single row of floor buttons, the floor buttons shall be set from left to right on the centre line of the plate. The “re-opening” door and alarm button shall be on the left of the car operating panel; the alarm button shall be above the “re-opening” door button with a gap of $10 \text{ mm} \pm 1 \text{ mm}$ between active parts.
 - In the case of two rows of floor buttons, the floor buttons shall be staggered above and below the centre line of the plate in growing order, from bottom to top and from left to right. The “re-opening” door and alarm button shall be on the left of the car operating panel; the alarm button shall be located on the centre line of the plate with a gap of $10 \text{ mm} \pm 1$ between active parts.
- f) For other car-operating panels, the requirements of 3.2.2.3.4 apply.

B.4 Passenger lift with nominal load > 1 275 kg

The requirements of 3.2.2.3.2 apply, except that the minimal dimension to the vertical axis from any corner of the car shall be 500 mm.

B.5 Hand rail

The requirements of Clause 4 are replaced by the following.

- The diameter of the handrail shall be minimum 30 mm and maximum 45 mm.
- The handrail shall be fixed from the floor at $850 \text{ mm} \pm 10$.
- The gripping part shall be located between 55 mm and 70 mm from the car panel.

Dimensions in millimetres

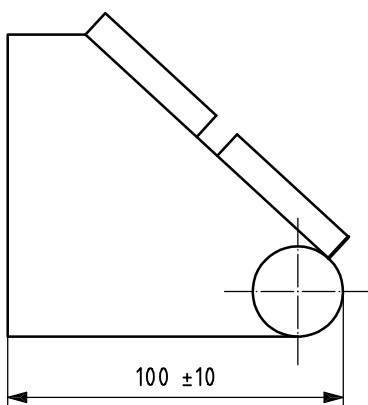
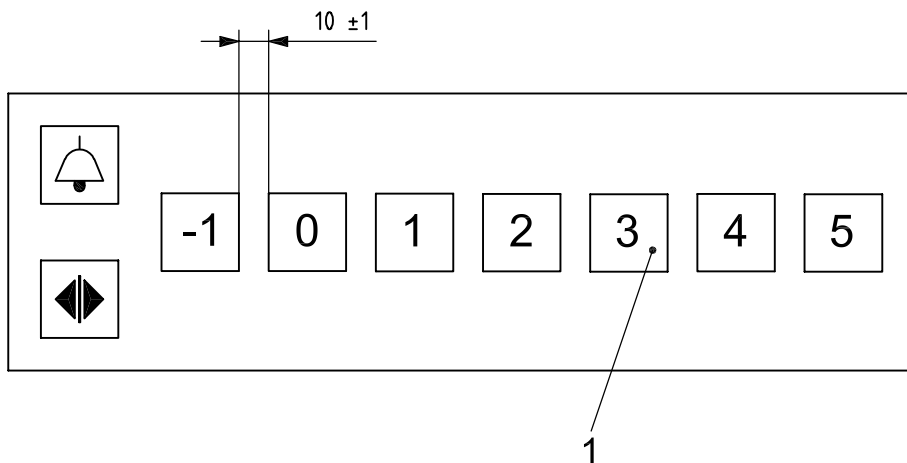

Figure B.1 — Special arrangement of horizontal car operating panel — Side view

Dimensions in millimetres



Key

- 1 square or circular buttons

Figure B.2 — Arrangement for single row of push buttons

Dimensions in millimetres

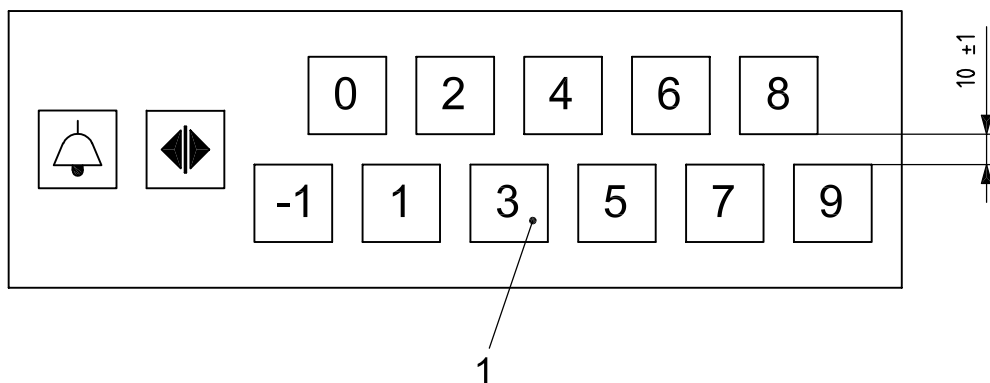

Key

- 1 square or circular buttons

Figure B.3 — Arrangement for two rows of push buttons

Annex C (normative)

Representative symbols

The symbols used shall be approximately as shown in Table C.1. These are only typical and need not be reproduced exactly.

Table C.1 — Representative symbols







| No. | Term | Description | Symbol |
|-----|------------------------|---|---|
| 1 | Alarm button | Bell-shaped symbol (ISO 7000) or simple bell |  |
| 2 | Door re-opening button | Stylized arrows ^a |  |
| 3 | Door closing button | Stylized arrows ^a |  |
| 4 | Telephone | Stylized receiver/handset symbol (ISO 7001) |  |
| 5 | "Not in use" signal | Red disc with white line similar to "Do not enter" sign |  |

Table C.1 (continued)

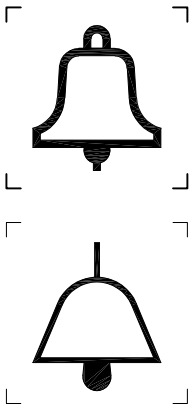
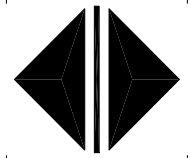
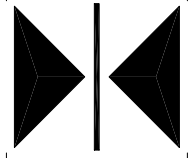
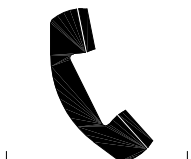
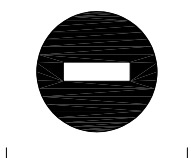
| No. | Term | Description | Symbol |
|---|---|---|---|
| 6 | Direction indication on call button indicator arrows direction arrows | Stylized arrows ^a |  |
| 7 | Overload indicator | Stylized balance dial |  |
| 8 | "Communication established" indicator | Stylized communication in green |  |
| 9 | "Induction loop" (AFILS) indicator | Standard AFILS symbol in light blue |  |
| 10 | Accessibility | International symbol of accessibility in blue |  |
| 11 | Star | Stylized star |  |
| 12 | STOP | Red disc with STOP written in black inside |  |
| NOTE For particular requirements, see Annex B. | | | |
| ^a Non-stylized arrows or arrow symbols according to ISO 7000 or ISO 4196 may also be used. | | | |

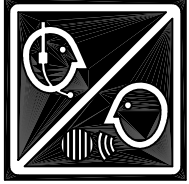
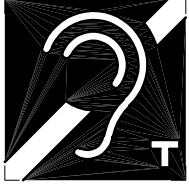
Bibliography

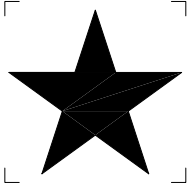
- [1] ISO 7000, *Graphical symbols for use on equipment — Index and synopsis*
- [2] ISO 7001, *Public information symbols*
- [3] ISO 4196, *Graphical symbols — Use of arrows*

BSI — British Standards Institution

BSI is the independent national body responsible for preparing British Standards. It presents the UK view on standards in Europe and at the international level. It is incorporated by Royal Charter.

Revisions

British Standards are updated by amendment or revision. Users of British Standards should make sure that they possess the latest amendments or editions.

It is the constant aim of BSI to improve the quality of our products and services. We would be grateful if anyone finding an inaccuracy or ambiguity while using this British Standard would inform the Secretary of the technical committee responsible, the identity of which can be found on the inside front cover.
Tel: +44 (0)20 8996 9000. Fax: +44 (0)20 8996 7400.

BSI offers members an individual updating service called PLUS which ensures that subscribers automatically receive the latest editions of standards.

Buying standards

Orders for all BSI, international and foreign standards publications should be addressed to Customer Services. Tel: +44 (0)20 8996 9001.
Fax: +44 (0)20 8996 7001. Email: orders@bsi-global.com. Standards are also available from the BSI website at <http://www.bsi-global.com>.

In response to orders for international standards, it is BSI policy to supply the BSI implementation of those that have been published as British Standards, unless otherwise requested.

Information on standards

BSI provides a wide range of information on national, European and international standards through its Library and its Technical Help to Exporters Service. Various BSI electronic information services are also available which give details on all its products and services. Contact the Information Centre.
Tel: +44 (0)20 8996 7111. Fax: +44 (0)20 8996 7048. Email: info@bsi-global.com.

Subscribing members of BSI are kept up to date with standards developments and receive substantial discounts on the purchase price of standards. For details of these and other benefits contact Membership Administration.
Tel: +44 (0)20 8996 7002. Fax: +44 (0)20 8996 7001.
Email: membership@bsi-global.com.

Information regarding online access to British Standards via British Standards Online can be found at <http://www.bsi-global.com/bsonline>.

Further information about BSI is available on the BSI website at <http://www.bsi-global.com>.

Copyright

Copyright subsists in all BSI publications. BSI also holds the copyright, in the UK, of the publications of the international standardization bodies. Except as permitted under the Copyright, Designs and Patents Act 1988 no extract may be reproduced, stored in a retrieval system or transmitted in any form or by any means – electronic, photocopying, recording or otherwise – without prior written permission from BSI.

This does not preclude the free use, in the course of implementing the standard, of necessary details such as symbols, and size, type or grade designations. If these details are to be used for any other purpose than implementation then the prior written permission of BSI must be obtained.

Details and advice can be obtained from the Copyright & Licensing Manager.
Tel: +44 (0)20 8996 7070. Fax: +44 (0)20 8996 7553.
Email: copyright@bsi-global.com.