

# Road vehicles — Multi-core connecting cables —

**Part 1: Test methods and requirements  
for basic performance sheathed cables**

ICS 43.040.10

## National foreword

This British Standard reproduces verbatim ISO 4141-1:2005 and implements it as the UK national standard. It supersedes BS AU 231:1989 which is withdrawn.

The UK participation in its preparation was entrusted to Technical Committee AUE/16, Electrical and electronic equipment, which has the responsibility to:

- aid enquirers to understand the text;
- present to the responsible international/European committee any enquiries on the interpretation, or proposals for change, and keep UK interests informed;
- monitor related international and European developments and promulgate them in the UK.

A list of organizations represented on this committee can be obtained on request to its secretary.

### Cross-references

The British Standards which implement international publications referred to in this document may be found in the *BSI Catalogue* under the section entitled “International Standards Correspondence Index”, or by using the “Search” facility of the *BSI Electronic Catalogue* or of British Standards Online.

This publication does not purport to include all the necessary provisions of a contract. Users are responsible for its correct application.

**Compliance with a British Standard does not of itself confer immunity from legal obligations.**

### Summary of pages

This document comprises a front cover, an inside front cover, the ISO title page, pages ii to iv, pages 1 to 12, an inside back cover and a back cover.

The BSI copyright notice displayed in this document indicates when the document was last issued.

### Amendments issued since publication

| Amd. No. | Date | Comments |
|----------|------|----------|
|          |      |          |
|          |      |          |
|          |      |          |
|          |      |          |

This British Standard was published under the authority of the Standards Policy and Strategy Committee on 12 January 2006

© BSI 12 January 2006

INTERNATIONAL  
STANDARD

**ISO**  
**4141-1**

Second edition  
2005-09-15

---

---

**Road vehicles — Multi-core connecting  
cables —**

Part 1:

**Test methods and requirements for basic  
performance sheathed cables**

*Véhicules routiers — Câbles de raccordement multiconducteurs —*

*Partie 1: Méthodes d'essai et exigences pour les câbles gainés à  
performance de base*



Reference number  
ISO 4141-1:2005(E)



**Contents**

Page

|  |    |
|--|----|
| Foreword.....                            | iv |
| 1 Scope .....                            | 1  |
| 2 Normative references .....             | 1  |
| 3 Terms and definitions.....             | 2  |
| 4 General.....                           | 2  |
| 5 Dimensions.....                        | 3  |
| 6 Electrical characteristics .....       | 5  |
| 7 Mechanical characteristics .....       | 6  |
| 8 Low temperature characteristics .....  | 8  |
| 9 Resistance to abrasion.....            | 9  |
| 10 Heat ageing.....                      | 9  |
| 11 Resistance to chemicals .....         | 9  |
| 12 Resistance to flame propagation ..... | 11 |
| 13 Artificial weathering.....            | 11 |
| Bibliography .....                       | 12 |

## **Foreword**

ISO (the International Organization for Standardization) is a worldwide federation of national standards bodies (ISO member bodies). The work of preparing International Standards is normally carried out through ISO technical committees. Each member body interested in a subject for which a technical committee has been established has the right to be represented on that committee. International organizations, governmental and non-governmental, in liaison with ISO, also take part in the work. ISO collaborates closely with the International Electrotechnical Commission (IEC) on all matters of electrotechnical standardization.

International Standards are drafted in accordance with the rules given in the ISO/IEC Directives, Part 2.

The main task of technical committees is to prepare International Standards. Draft International Standards adopted by the technical committees are circulated to the member bodies for voting. Publication as an International Standard requires approval by at least 75 % of the member bodies casting a vote.

Attention is drawn to the possibility that some of the elements of this document may be the subject of patent rights. ISO shall not be held responsible for identifying any or all such patent rights.

ISO 4141-1 was prepared by Technical Committee ISO/TC 22, *Road vehicles*, Subcommittee SC 3, *Electrical and electronic equipment*.

This second edition cancels and replaces the first edition (ISO 4141-1:1998), which has been technically revised.

ISO 4141 consists of the following parts, under the general title *Road vehicles — Multi-core connecting cables*:

- *Part 1: Test methods and requirements for basic performance sheathed cables*
- *Part 2: Test methods and requirements for high-performance sheathed cables*
- *Part 3: Construction, dimensions and marking of unscreened sheathed low-voltage cables*
- *Part 4: Articulation test method and requirements for coiled cable assemblies*

# Road vehicles — Multi-core connecting cables —

## Part 1: Test methods and requirements for basic performance sheathed cables

### 1 Scope

This part of ISO 4141 specifies the test methods and requirements of basic performance multi-core sheathed cables for the connection of towing and towed vehicles, suitable for a temperature range of  $-40\text{ }^{\circ}\text{C}$  to  $+85\text{ }^{\circ}\text{C}$ .

### 2 Normative references

The following referenced documents are indispensable for the application of this document. For dated references, only the edition cited applies. For undated references, the latest edition of the referenced document (including any amendments) applies.

ISO 1817, *Rubber, vulcanised — Determination of the effect of liquids*

ISO 4141-3 *Road vehicles — Multi-core connecting cables — Part 3: Construction, dimensions and marking of unscreened sheathed low-voltage cables*

ISO 4892-2, *Plastics — Methods of exposure to laboratory light sources — Part 2: Xenon-arc sources*

ISO 4892-4, *Plastics — Methods of exposure to laboratory light sources — Part 4: Open-flame carbon-arc lamps*

ISO 6722, *Road vehicles — 60 V and 600 V single-core cables — Dimensions, test methods and requirements*

ISO 7638-1, *Road vehicles — Connectors for the electrical connection of towing and towed vehicles — Part 1: Connectors for braking systems and running gear of vehicles with 24 V nominal supply voltage*

ISO 7638-2, *Road vehicles — Connectors for the electrical connection of towing and towed vehicles — Part 2: Connectors for braking systems and running gear of vehicles with 12 V nominal supply voltage*

ISO 12098, *Road vehicles — Connectors for the electrical connection of towing and towed vehicles — 15-pole connector for vehicles with 24 V nominal supply voltage*

ISO 14572, *Road vehicles — Round, screened and unscreened, 60 V and 600 V multi-core sheathed cables — Test methods and requirements for basic and high performance cables*

ISO/PAS 16553, *Road vehicles — Data cables — Test methods and requirements*

IEC 60811-1-1, *Common test methods for insulating and sheathing materials of electric cables and optical cables — Part 1-1: Methods for general application — Measurement of thickness and overall dimensions — Tests for determining the mechanical properties*

EN 14214, *Automotive fuels — Fatty acid methyl esters (FAME) for diesel engines — Requirements and test methods*

DIN V 70070, *Diesel engines — NO<sub>x</sub>-reduction additives AUS 32 — Requirements and test methods*

### **3 Terms and definitions**

For the purposes of this document, the terms and definitions given in ISO 6722 and the following apply.

#### **3.1 basic performance**

⟨cable⟩ meeting basic requirements for general automotive applications

#### **3.2 screen**

conductive material intended to reduce the penetration and/or radiation of a varying electromagnetic field into an assigned region

#### **3.3 unscreened**

absence of a screen

#### **3.4 core**

an assembly comprising a conductor with its own insulation (and screens, if there are any)

### **4 General**

Single core identification shall conform to ISO 4141-3. The single components of multi-core sheathed cables shall comply with ISO 6722 for single cores, and with ISO/PAS 16553 for data cables, with the exception of the capacitance test of unscreened twisted pair cores for which 6.3 shall apply.

The general test conditions and the ovens used shall be in accordance with ISO 6722.

If a visual examination is required, the sheath shall be smooth, even and free from surface imperfections, e.g. lumps, voids and particles.

The test sequence for each sample group shall be in accordance with Table 1. (Sequences are indicated with an "X", ordered from top to bottom.)



Table 1 — Test sequences and requirements

| Test                              | Test sample group / sequence |   |   |   |   |   |   |   |   |   |   |   |   |   |   |   |   |   |   |   |
|-----------------------------------|------------------------------|---|---|---|---|---|---|---|---|---|---|---|---|---|---|---|---|---|---|---|
|                                   | Subclause                    | A | B | C | D | E | F | G | H | I | J | K | L | M | N | O | P | Q | R |   |
| Visual examination                | 4                            | X | X | X | X | X | X | X | X | X | X | X | X | X | X | X | X | X | X | X |
| Outside cable diameter            | 5.1                          | X |   |   |   |   |   |   |   |   |   |   |   |   |   |   |   |   |   |   |
| Ovality                           | 5.2                          | X |   |   |   |   |   |   |   |   |   |   |   |   |   |   |   |   |   |   |
| Thickness of the sheath           | 5.3                          |   | X |   |   |   |   |   |   |   |   |   |   |   |   |   |   |   |   |   |
| Lay length                        | 5.4                          |   |   | X |   |   |   |   |   |   |   |   |   |   |   |   |   |   |   |   |
| Continuity                        | 6.1                          |   |   |   | X |   |   |   |   |   |   |   |   |   |   |   |   |   |   |   |
| Withstand voltage                 | 6.2                          |   |   |   |   | X |   |   |   | X |   |   | X | X |   |   |   |   |   |   |
| Cyclic bending                    | 7.3                          |   |   |   |   | X |   |   |   |   |   |   |   |   |   |   |   |   |   |   |
| Winding                           | 8.1                          |   |   |   |   |   |   |   |   | X |   |   |   |   |   |   |   |   |   |   |
| Impact                            | 8.2                          |   |   |   |   |   |   |   |   |   | X |   |   |   |   |   |   |   |   |   |
| Long-term ageing                  | 10.1                         |   |   |   |   |   |   |   |   |   |   |   | X |   |   |   |   |   |   |   |
| Short-term ageing                 | 10.2                         |   |   |   |   |   |   |   |   |   |   |   |   | X |   |   |   |   |   |   |
| Visual examination                | 4                            |   |   |   |   | X |   |   |   | X | X |   | X | X |   |   |   |   |   |   |
| Withstand voltage                 | 6.2                          |   |   |   |   | X |   |   |   | X |   |   | X | X |   |   |   |   |   |   |
| Capacitance                       | 6.3                          |   |   |   |   |   | X |   |   |   |   |   |   |   |   |   |   |   |   |   |
| Pressure at high temperature      | 7.1                          |   |   |   |   |   |   | X |   |   |   |   |   |   |   |   |   |   |   |   |
| Adhesion of the sheath            | 7.2                          |   |   |   |   |   |   |   | X |   |   |   |   |   |   |   |   |   |   |   |
| Resistance to abrasion            | 9                            |   |   |   |   |   |   |   |   |   |   | X |   |   |   |   |   |   |   |   |
| Fluid compatibility of the sheath | 11.1                         |   |   |   |   |   |   |   |   |   |   |   |   |   | X |   |   |   |   |   |
| Durability of sheath marking      | 11.2                         |   |   |   |   |   |   |   |   |   |   |   |   |   |   | X |   |   |   |   |
| Resistance to ozone               | 11.3                         |   |   |   |   |   |   |   |   |   |   |   |   |   |   |   | X |   |   |   |
| Resistance to flame propagation   | 12                           |   |   |   |   |   |   |   |   |   |   |   |   |   |   |   |   | X |   |   |
| Artificial weathering             | 13                           |   |   |   |   |   |   |   |   |   |   |   |   |   |   |   |   |   |   | X |
| Visual examination                | 4                            |   |   |   |   |   |   |   | X |   |   |   |   |   | X | X | X | X | X | X |

## 5 Dimensions

### 5.1 Outside cable diameter

#### 5.1.1 Test sample

Prepare a test sample of 600 mm length.

#### 5.1.2 Apparatus

See ISO 6722.

**5.1.3 Procedure**

Determine the maximum and minimum outside cable diameter by taking three sets of measurements separated by 200 mm and recording the highest ( $d_{\max}$ ) and lowest ( $d_{\min}$ ) values of the measurements at each of the three positions.

**5.1.4 Requirement**

Each diameter measured shall be between the limits agreed between customer and supplier for the cable under test, which shall be within the limits according to ISO 4141-3.

**5.2 Ovality**

**5.2.1 Test sample and apparatus**

Use the measurements of 5.1.

**5.2.2 Procedure**

Calculate the ovality, for each set of measurements, as follows:

$$\text{Ovality (\%)} = \frac{d_{\max} - d_{\min}}{0,5(d_{\max} + d_{\min})} \times 100$$

**5.2.3 Requirement**

Each ovality calculated shall be within the limits, as specified in ISO 4141-3.

**5.3 Thickness of the sheath**

**5.3.1 Test samples, apparatus, procedure**

See ISO 6722, insulation thickness.

**5.3.2 Requirement**

Each value measured shall not be less than the minimum wall thickness, as specified in ISO 4141-3.

**5.4 Lay length**

**5.4.1 General**

This test is intended for twisted pair cores only.

**5.4.2 Test samples**

Prepare a test sample of 1 000 mm length.

**5.4.3 Apparatus**

Use a measuring device with an accuracy of 1 mm.

#### 5.4.4 Procedure

Remove  $(500 \pm 25)$  mm of the sheath without allowing the ends to untwist. Fasten the test sample at its ends. Measure the length over five consecutive lays, where one lay is the axial length of one complete turn of the helix of a core in the twisted pair.

#### 5.4.5 Requirement

The length measured shall not exceed 250 mm for five lays.

## 6 Electrical characteristics

### 6.1 Continuity

See ISO 14572.

### 6.2 Withstand voltage

See ISO 14572.

### 6.3 Capacitance

#### 6.3.1 General

This test is intended for unshielded twisted pair cores used for data communication only.

#### 6.3.2 Test samples

Prepare a test sample of 5 m length, remove 50 mm of sheath from one end and remove 12 mm of insulation from each of the cores.

#### 6.3.3 Apparatus

Use a standard capacitance measuring device with alternating current and a frequency of 1 kHz.

#### 6.3.4 Procedure

Cores a and b are cores for data transmission of the connecting cable, e.g. cores 6 and 7 of a cable in accordance with ISO 7638-1 or ISO 7638-2, or cores 14 and 15 of a cable in accordance with ISO 12098.

Subject cores a and b to the two different capacitance measurements A and B, as described below (see also Figure 1).

##### Measurement A:

Short circuit cores a and b. Set the short-circuit bridge at that cable end, where the measuring device is connected. Measure the capacitance  $C_A$  between these cores and all other cores connected in parallel.

The measured value is:  $C_A = 2 C_i$  (1a)

$$C_i = \frac{1}{2} C_A \quad (1b)$$

##### Measurement B:

Remove the short circuit between core a and core b. Measure the capacitance  $C_B$  between core a and core b.

The measured value is:  $C_B = C_d + \frac{1}{2} C_i$  (2a)

$$C_d = C_B - \frac{1}{2} C_i \quad (2b)$$

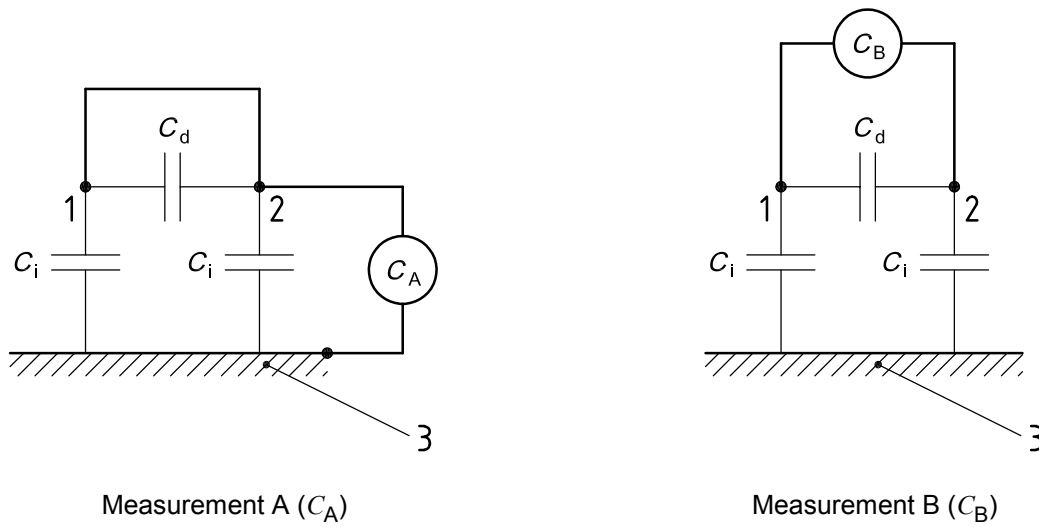

**Key**

- 1 Core a
- 2 Core b
- 3 all other cores connected in parallel

**Figure 1 — Capacitance measurement**

**6.3.5 Requirements**

The capacitance per length shall not exceed the values given in Table 2 for:

- $C_i$ : capacitance between each data core and all other cores connected in parallel;
- $C_d$ : capacitance between the data cores; and
- $C_{bus}$ : bus capacitance,  $C_{bus} = C_i + 2 C_d = 2 C_B$ .

**Table 2 — Maximum capacitance per length**

| Cable          | $C_i$    | $C_d$   | $C_{bus}$ |
|----------------|----------|---------|-----------|
| Uncoiled cable | 100 pF/m | 50 pF/m | 160 pF/m  |
| Coiled cable   | 170 pF/m | 85 pF/m | 270 pF/m  |

NOTE  $C_{bus}$  is the determinant value. For  $C_i$  and  $C_d$  separately, the maximum values given in the table are allowed. However, because  $C_{bus} = C_i + 2 C_d$ , the maximum value for  $C_{bus}$  restricts the allowed values for  $C_i$  and  $C_d$ .

**7 Mechanical characteristics**

**7.1 Pressure test at high temperature**

The requirements for basic performance cables in ISO 14572 shall apply.

**7.2 Adhesion of the sheath**

See ISO 14572.

### 7.3 Cyclic bending

#### 7.3.1 General

This test applies to uncoiled cables only.

#### 7.3.2 Test samples

Take two test samples of 600 mm length from points separated by at least 1 m.

#### 7.3.3 Apparatus

The apparatus shall be similar to the one shown in Figure 2. Any apparatus is acceptable as long as it meets the following requirements:

- $R = 40$  mm;
- a force  $F = 50$  N;
- a fixture that bends the test sample  $\pm 90^\circ$  at a rate of 15 cycles/min;
- if a mass is used, a guide may be applied to stop the mass from swinging; and
- conductor breakage shall be monitored by applying a current ( $5 \pm 0,5$ ) A to all conductors during the entire test phase. If breakage occurs, the test procedure shall stop automatically.

Dimensions in millimetres

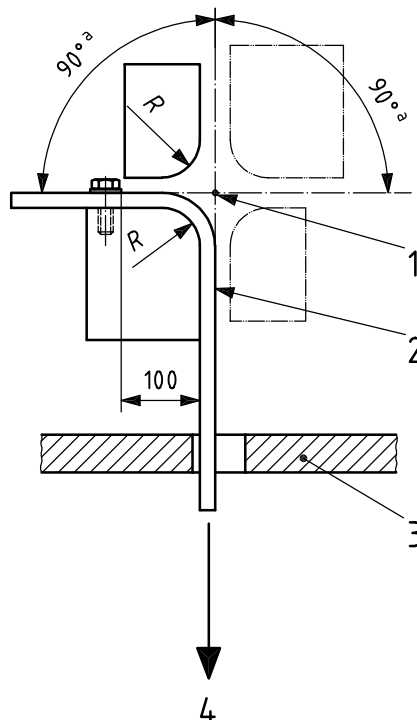

#### Key

- <sup>a</sup> cycle ( $90^\circ$  to each side)
- |   |       |   |                        |
|---|-------|---|------------------------|
| 1 | pivot | 3 | fixed guide (optional) |
| 2 | cable | 4 | force $F$              |

Figure 2 — Apparatus for cyclic bending

7.3.4 Procedure

Mount the test sample with one end attached to the flexing member and the other end loaded by the force  $F$ . Flex the test sample for 5 000 cycles at a speed of 15 cycles/min.

7.3.5 Requirement

No conductor shall break during the test. The samples shall show no cracks when inspected visually. If the samples meet this requirement, perform the tests specified in 6.2.

8 Low temperature characteristics

8.1 Winding

8.1.1 Test sample

See ISO 6722. Remove 100 mm of sheath from one end of the cable and remove 25 mm of insulation from each core.

8.1.2 Apparatus

See ISO 6722. A freezing chamber at  $(-40 \pm 2) ^\circ\text{C}$  shall be used. The mandrel shall have a diameter of 80 mm and the mass shall be 20 kg.

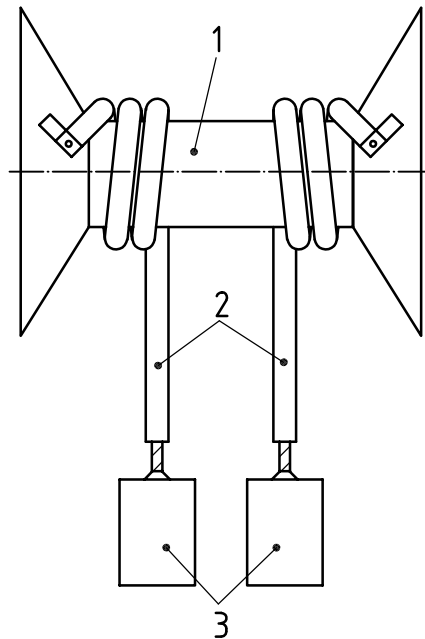

Key

- 1 mandrel
- 2 test sample(s)
- 3 mass(es)

Figure 3 — Apparatus for winding

### 8.1.3 Procedure

See ISO 6722.

After conditioning, bend the samples 180° around the mandrel. The bending shall take place within 5 s in the freezing chamber. After winding, allow the test samples to regain room temperature.

### 8.1.4 Requirements

The test samples, when visually examined, shall show no cracks. If the samples meet this requirement, perform the withstand voltage test as specified in 6.2.

## 8.2 Impact

### 8.2.1 Test samples

Prepare three samples of a minimum length of 150 mm.

### 8.2.2 Apparatus

See ISO 6722. The mass of the hammer is 500 g.

### 8.2.3 Procedure

See ISO 6722. After impact, allow the test samples to regain room temperature.

### 8.2.4 Requirement

The test samples, when visually examined, shall show no cracks.

## 9 Resistance to abrasion

See ISO 14572. The usage of this test will be established by agreement between customer and supplier.

## 10 Heat ageing

### 10.1 Long-term ageing, 3 000 h

See ISO 14572. This test is intended to confirm the temperature class of –40 °C to +85 °C. Apply the appropriate test temperature of class A according to ISO 6722.

### 10.2 Short-term ageing, 240 h

See ISO 14572, but use a mandrel of 60 mm diameter. This test is intended to simulate thermal excursions for –40 °C to +85 °C cables. Apply the appropriate test temperature of class A according to ISO 6722.

## 11 Resistance to chemicals

### 11.1 Fluid compatibility of the sheath

NOTE There is a separate International Standard in preparation concerning fluid testing. As long as this International Standard is not available, the tests described at this chapter are valid. It is intended to revise this International Standard as soon as a comprehensive International Standard concerning fluid testing which is applicable also to cables and connectors is available.

**11.1.1 Test samples**

See ISO 6722.

**11.1.2 Apparatus**

Use an apparatus as shown in Figure 3. The mandrel shall have a diameter of 80 mm and the mass shall be 20 kg. The minimum number of turns shall be 0,5.

**Table 3 — Test liquids for fluid compatibility of the sheath**

| Test liquid   | Liquid specification | Test Temperature<br>(°C) | Test duration<br>(h) |
|---|----------------------|--------------------------|----------------------|
| Gasoline  | ISO 1817, liquid B   | 23 ± 5                   | 20                   |
| Gasoline  | ISO 1817, liquid C   | 23 ± 5                   | 20                   |
| Gasoline  | ISO 1817, liquid D   | 23 ± 5                   | 20                   |
| Diesel  | ISO 1817, liquid F   | 23 ± 5                   | 20                   |
| Urea  | DIN V 70070          | 23 ± 5                   | 20                   |
| Lubricating oil   | ISO 1817, oil No. 1  | 50 ± 3                   | 20                   |
| Lubricating grease  | ISO 1817, liquid 101 | 50 ± 3                   | 20                   |
| Hydraulic oil <sup>a</sup>  | ISO 1817, liquid 102 | 23 ± 5                   | 20                   |
| Engine coolant <sup>a</sup>   | b                    | 50 ± 3                   | 20                   |
| Brake fluid <sup>a</sup>  | b                    | 23 ± 5                   | 20                   |
| Rape fuel Methyl Ester <sup>a</sup>   | EN 14214             | 23 ± 5                   | 20                   |
| <sup>a</sup> If agreed between customer and supplier.<br><sup>b</sup> As defined between customer and supplier. |                      |                          |                      |

**11.1.3 Procedure**

Immerse each test sample into the test liquid using the temperature and duration, as defined in Table 3. Remove the test sample from the fluid and wipe the surface to remove any remaining liquid and allow it to dry at room temperature for 30 minutes. Within 5 minutes after the drying period, wind the cable using the apparatus described in 11.1.2 The minimum number of turns shall be 0,5.

**11.1.4 Requirements**

After winding (whilst the sample is still on the mandrel), the sample shall show no cracks. Other requirements shall be by agreement between customer and supplier.

**11.2 Durability of sheath marking**

**11.2.1 General**

This test only applies if marking is required.

**11.2.2 Test Samples**

Prepare a test sample of at least 300 mm length for each test fluid, as specified in Table 3.



### **11.2.3 Apparatus**

See ISO 6722, durability of cable marking.

### **11.2.4 Procedure**

See ISO 6722, but apply the test for all the test fluids, as specified in Table 3.

### **11.2.5 Requirements**

See ISO 6722. Only the outer sheath shall be examined.

## **11.3 Resistance to ozone**

See ISO 14572. The usage of this test shall be established by agreement between the customer and supplier.

## **12 Resistance to flame propagation**

See ISO 14572.

## **13 Artificial weathering**

### **13.1 General**

The usage of this test shall be established by agreement between customer and supplier.

### **13.2 Test sample**

Take 10 tensile test samples according to IEC 60811-1-1 from the sheath of the cable to be tested.

### **13.3 Apparatus**

Use an ultraviolet radiation cabinet according to ISO 4892-2 with a Xenon arc lamp at  $(55 \pm 3)$  °C, water spray cycles (5 min water spray and 25 min dry interval, or 12 min and 180 min, respectively) and a relative humidity of  $(50 \pm 5)$  % for the dry intervals.

The preferred test device is the xenon arc test cabinet. Other cabinets using other light sources, e.g. open flame carbon arc (see ISO 4892-4), are acceptable by agreement between the cable manufacturer and the user. In case of any dispute, the referee method shall be the xenon arc lamp test.

### **13.4 Procedure**

Condition five of the samples in the test cabinet for 750 h. After removal from the test cabinet, allow the samples to attain room temperature and then subject them to the tensile test according to IEC 60811-1-1, together with the remaining five samples.

### **13.5 Requirement**

After exposure to the artificial weathering, the elongation shall not lose more than 20 % of the original measured value.

## Bibliography

- [1] ISO/IEC TR 10000-1, *Information technology — Framework and taxonomy of International Standardized Profiles — Part 1: General principles and documentation framework*
- [2] ISO/IEC Directives, Part 2, *Rules for the structure and drafting of International Standards, 2004*
- [3] ISO 31 (all parts), *Quantities and units*
- [4] ISO 690, *Documentation — Bibliographic references — Content, form and structure*
- [5] ISO 1000, *SI units and recommendations for the use of their multiples and of certain other units*
- [6] ISO 1431-1, *Rubber, vulcanized or thermoplastic — Resistance to ozone cracking — Part 1: Static strain testing*
- [7] ISO 4892-1, *Plastics — Methods of exposure to laboratory light sources — Part 1: General guidance*
- [8] ISO 10241, *International terminology standards — Preparation and layout*
- [9] IEC 60027 (all parts), *Letter symbols to be used in electrical technology*
- [10] IEC 60757, *Code for designation of colours*
- [11] IEC 60811-2-1, *Common test methods for insulating and sheathing materials of electric and optical cables — Part 2: Methods specific to elastomeric compounds — Section 1: Ozone resistance, hot set and mineral oil immersion tests*



---

---

## BSI — British Standards Institution

BSI is the independent national body responsible for preparing British Standards. It presents the UK view on standards in Europe and at the international level. It is incorporated by Royal Charter.

### Revisions

British Standards are updated by amendment or revision. Users of British Standards should make sure that they possess the latest amendments or editions.

It is the constant aim of BSI to improve the quality of our products and services. We would be grateful if anyone finding an inaccuracy or ambiguity while using this British Standard would inform the Secretary of the technical committee responsible, the identity of which can be found on the inside front cover.  
Tel: +44 (0)20 8996 9000. Fax: +44 (0)20 8996 7400.

BSI offers members an individual updating service called PLUS which ensures that subscribers automatically receive the latest editions of standards.

### Buying standards

Orders for all BSI, international and foreign standards publications should be addressed to Customer Services. Tel: +44 (0)20 8996 9001.  
Fax: +44 (0)20 8996 7001. Email: [orders@bsi-global.com](mailto:orders@bsi-global.com). Standards are also available from the BSI website at <http://www.bsi-global.com>.

In response to orders for international standards, it is BSI policy to supply the BSI implementation of those that have been published as British Standards, unless otherwise requested.

### Information on standards

BSI provides a wide range of information on national, European and international standards through its Library and its Technical Help to Exporters Service. Various BSI electronic information services are also available which give details on all its products and services. Contact the Information Centre.  
Tel: +44 (0)20 8996 7111. Fax: +44 (0)20 8996 7048. Email: [info@bsi-global.com](mailto:info@bsi-global.com).

Subscribing members of BSI are kept up to date with standards developments and receive substantial discounts on the purchase price of standards. For details of these and other benefits contact Membership Administration.  
Tel: +44 (0)20 8996 7002. Fax: +44 (0)20 8996 7001.  
Email: [membership@bsi-global.com](mailto:membership@bsi-global.com).

Information regarding online access to British Standards via British Standards Online can be found at <http://www.bsi-global.com/bsonline>.

Further information about BSI is available on the BSI website at <http://www.bsi-global.com>.

### Copyright

Copyright subsists in all BSI publications. BSI also holds the copyright, in the UK, of the publications of the international standardization bodies. Except as permitted under the Copyright, Designs and Patents Act 1988 no extract may be reproduced, stored in a retrieval system or transmitted in any form or by any means – electronic, photocopying, recording or otherwise – without prior written permission from BSI.

This does not preclude the free use, in the course of implementing the standard, of necessary details such as symbols, and size, type or grade designations. If these details are to be used for any other purpose than implementation then the prior written permission of BSI must be obtained.

Details and advice can be obtained from the Copyright & Licensing Manager.  
Tel: +44 (0)20 8996 7070. Fax: +44 (0)20 8996 7553.  
Email: [copyright@bsi-global.com](mailto:copyright@bsi-global.com).