

Safety devices for protection against excessive pressure

**Part 9: Application and installation of
safety devices excluding stand-alone
bursting disc safety devices**

ICS 13.240; 23.060.40

National foreword

This British Standard is the UK implementation of ISO 4126-9:2008.

The UK participation in its preparation was entrusted to Technical Committee PVE/12, Safety devices.

A list of organizations represented on this committee can be obtained on request to its secretary.

This publication does not purport to include all the necessary provisions of a contract. Users are responsible for its correct application.

Compliance with a British Standard cannot confer immunity from legal obligations.

This British Standard was published under the authority of the Standards Policy and Strategy Committee on 31 October 2008

© BSI 2008

ISBN 978 0 580 55250 2

Amendments/corrigenda issued since publication

Date	Comments

**Safety devices for protection against
excessive pressure —**

Part 9:

**Application and installation of safety
devices excluding stand-alone bursting
disc safety devices**

*Dispositifs de sécurité pour protection contre les pressions
excessives —*

*Partie 9: Application et installation des dispositifs de sécurité autres que
les dispositifs à disque de rupture installés seuls*



PDF disclaimer

This PDF file may contain embedded typefaces. In accordance with Adobe's licensing policy, this file may be printed or viewed but shall not be edited unless the typefaces which are embedded are licensed to and installed on the computer performing the editing. In downloading this file, parties accept therein the responsibility of not infringing Adobe's licensing policy. The ISO Central Secretariat accepts no liability in this area.

Adobe is a trademark of Adobe Systems Incorporated.

Details of the software products used to create this PDF file can be found in the General Info relative to the file; the PDF-creation parameters were optimized for printing. Every care has been taken to ensure that the file is suitable for use by ISO member bodies. In the unlikely event that a problem relating to it is found, please inform the Central Secretariat at the address given below.



COPYRIGHT PROTECTED DOCUMENT

© ISO 2008

All rights reserved. Unless otherwise specified, no part of this publication may be reproduced or utilized in any form or by any means, electronic or mechanical, including photocopying and microfilm, without permission in writing from either ISO at the address below or ISO's member body in the country of the requester.

ISO copyright office
Case postale 56 • CH-1211 Geneva 20
Tel. + 41 22 749 01 11
Fax + 41 22 749 09 47
E-mail copyright@iso.org
Web www.iso.org

Published in Switzerland

Contents

Page

Foreword.....	iv
Introduction	v
1 Scope	1
2 Normative references	1
3 Terms and definitions.....	1
4 Risk consideration.....	3
5 Pressure limitation.....	4
5.1 General.....	4
5.2 Setting of safety devices.....	5
6 Inlet line	6
7 Outlet line	6
8 Installation	8
8.1 General.....	8
8.2 Installation of safety valves or the main valve of a CSPRS or a POSV.....	8
8.3 Installation of safety valves and bursting disc safety devices in series or parallel	9
8.4 Isolation of safety devices	10
9 Lifting device.....	11
Annex A (informative) Safety device applications	12
Annex B (informative) Sizing of multiple safety devices.....	15
Annex C (informative) Sizing of inlet lines.....	17
Annex D (informative) Calculation of built-up back pressure.....	22
Annex E (informative) Calculation of reaction forces.....	29
Annex F (informative) Calculation of noise level	30
Bibliography	31

Foreword

ISO (the International Organization for Standardization) is a worldwide federation of national standards bodies (ISO member bodies). The work of preparing International Standards is normally carried out through ISO technical committees. Each member body interested in a subject for which a technical committee has been established has the right to be represented on that committee. International organizations, governmental and non-governmental, in liaison with ISO, also take part in the work. ISO collaborates closely with the International Electrotechnical Commission (IEC) on all matters of electrotechnical standardization.

International Standards are drafted in accordance with the rules given in the ISO/IEC Directives, Part 2.

The main task of technical committees is to prepare International Standards. Draft International Standards adopted by the technical committees are circulated to the member bodies for voting. Publication as an International Standard requires approval by at least 75 % of the member bodies casting a vote.

Attention is drawn to the possibility that some of the elements of this document may be the subject of patent rights. ISO shall not be held responsible for identifying any or all such patent rights.

ISO 4126-9 was prepared by Technical Committee ISO/TC 185, *Safety devices for protection against excessive pressure*.

ISO 4126 consists of the following parts, under the general title *Safety devices for protection against excessive pressure*:

- *Part 1: Safety valves*
- *Part 2: Bursting disc safety devices*
- *Part 3: Safety valves and bursting disc safety devices in combination*
- *Part 4: Pilot-operated safety valves*
- *Part 5: Controlled safety pressure relief systems (CSPRS)*
- *Part 6: Application, selection and installation of bursting disc safety devices*
- *Part 7: Common data*
- *Part 9: Application and installation of safety devices excluding stand-alone bursting disc safety devices*
- *Part 10: Sizing of safety valves and connected inlet and outlet lines for gas/liquid two-phase flow*

Introduction

A safety device or system is the final element to protect pressure equipment from exceeding its allowable limits. Regulating and/or monitoring devices are not ultimate safety devices in the meaning of this International Standard. They become active in advance of an ultimate safety device (see Figure 1).

It is important to consider not only the pressure-relieving device but also the whole of the equipment protected, so as not to reduce the relieving capacity or adversely affect the proper operation of the pressure-relieving devices, in order to ensure that the relieving pressure is not exceeded. The value of the relieving pressure is $1,x$ times the maximum allowable pressure, P_S , where x is defined by a directive or national regulation. Operating problems can occur in pressure relief because of the selection of an inappropriate device or because a correctly selected device is adversely affected by improper handling, wrong installation or lack of maintenance.

In some cases, it can be necessary to determine the basic details of the equipment protected so as to ensure that the maximum relieving pressure is not exceeded.

NOTE 1 There can be requirements in a number of regulations to be respected and it is the responsibility of the user of this part of ISO 4126 to ensure compliance with these requirements. This part of ISO 4126 is also intended to draw attention to subjects that are not within its scope, but which are relevant to safety devices.

NOTE 2 To cover the essential requirements of the various regulations, a safety device needs to incorporate a whole range of products. Many of these products are covered by International Standards, but there are others that will either never be standardized or that will not be standardized within the foreseeable future. Where standards have already been produced, where work is known to be proceeding or where there is the intention of producing an applicable standard, reference is made to the standard concerned. Where there is no standard to which to refer, this part of ISO 4126 merely specifies the essential requirements of the device.

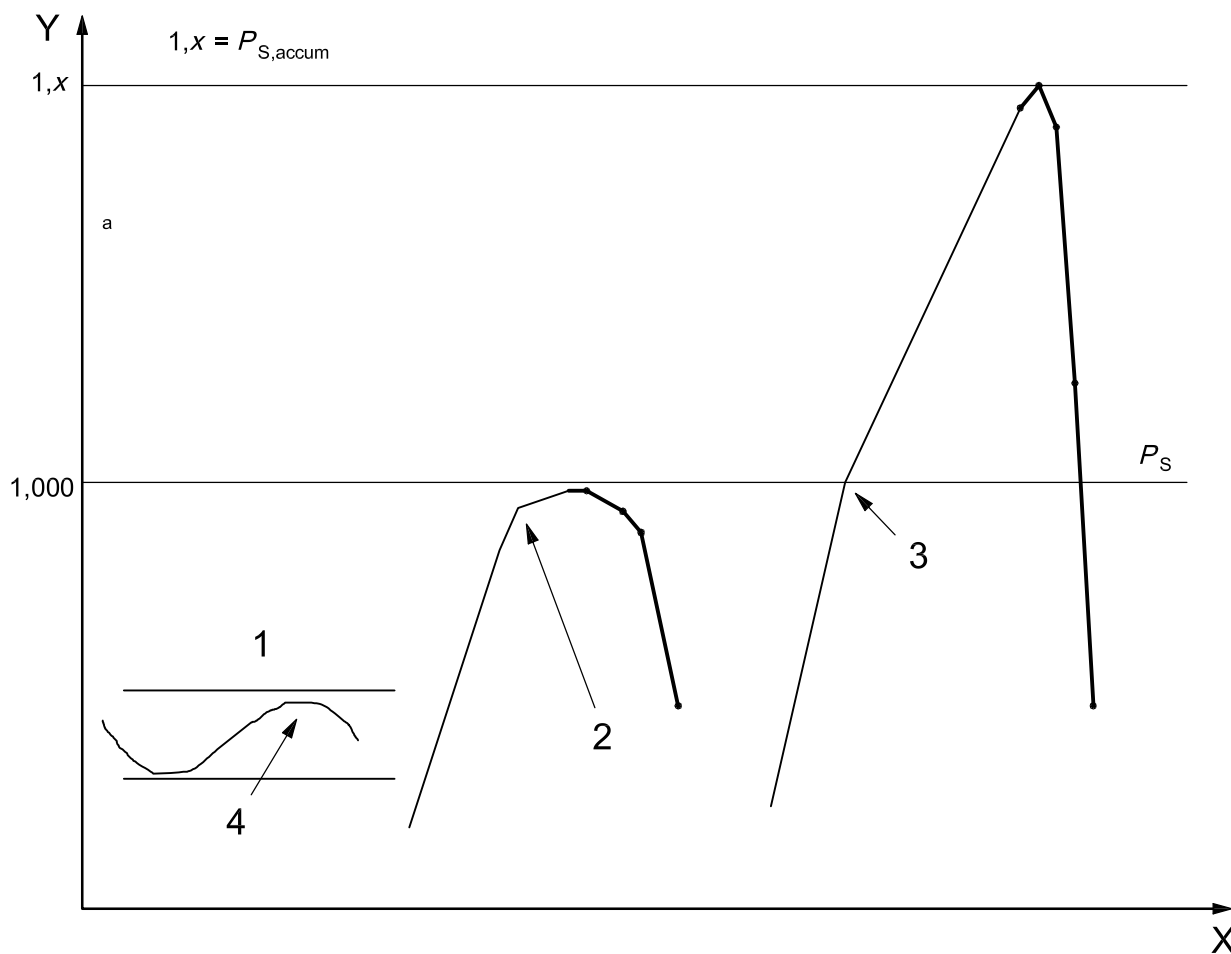

Key

X time
 Y pressure

- 1 reaction of regulating control system
- 2 reaction of monitoring system
- 3 reaction of safety system
- 4 normal operating range
- P_S maximum allowable pressure
- $P_{S,accum}$ maximum allowable accumulated pressure ($P_S \times 1,x$)

a No continuous operation in this zone.

Figure 1 — Diagram of typical system relationship

Safety devices for protection against excessive pressure —

Part 9:

Application and installation of safety devices excluding stand-alone bursting disc safety devices

1 Scope

This part of ISO 4126 covers the application and installations of safety devices such as safety valves, safety valves and bursting disc safety devices in combination, pilot-operated safety valves and controlled safety pressure-relief systems for the protection of pressure equipment. ISO 4126-6 covers the selection, application and installation of bursting disc safety devices.

This part of ISO 4126 describes the normative requirements for applications and installations of safety devices to protect static pressure equipment. The information contained in this part of ISO 4126 assumes single-phase flow of the fluid discharged from the safety device. ISO 4126-10 provides guidance specific to two-phase flow conditions.

Equipment connected together in a system by piping of adequate capacity, which is free from potential blockages and does not contain any valve that can isolate any part, can be considered to be a safety system for the application of pressure relief.

This part of ISO 4126 does not deal with other safety devices, such as safety related monitoring, control and regulation devices and other limiting devices allowed by some national regulations.

2 Normative references

The following referenced documents are indispensable for the application of this document. For dated references, only the edition cited applies. For undated references, the latest edition of the referenced document (including any amendments) applies.

ISO 4126-6, *Safety devices for protection against excessive pressure — Part 6: Application, selection and installation of bursting disc safety devices*

3 Terms and definitions

For the purposes of this document, the following terms and definitions apply.

3.1

safety device

device that serves as the ultimate protection to ensure that the maximum allowable accumulated pressure is not exceeded

EXAMPLE Safety valves, bursting disc safety devices, etc.

3.2
safety system

system including the safety devices and the interconnections between the equipment to be protected and any discharge connection to the nearest location of a safe disposal place

NOTE This location can either be an atmospheric outlet or the connection into a safe collecting system or flare.

3.3
fail-safe

status such that the pressure equipment remains in a safe condition in case of failure of any safety system component or energy source

3.4
self-diagnosis

regular and automatic determination that all chosen components of a safety system are capable of functioning as required

3.5
redundancy

provision of more than one device or system such that the necessary function will still be provided in case of failure of one or more of these devices

3.6
independence

ability to function as required without interference from other equipment

3.7
hazard

potential source of harm

NOTE 1 The term "hazard" can be qualified in order to define its origin or the nature of the expected harm (see ISO/IEC Guide 51).

NOTE 2 Harm is the physical injury or damage to the health of people, or damage to property or to the environment.

3.8
risk

combination of the probability of occurrence of harm and the severity of that harm

NOTE See ISO/IEC Guide 51.

3.9
risk analysis

use of available information to identify hazards and to estimate the risk

NOTE See ISO/IEC Guide 51.

3.10
risk evaluation

judgement on the basis of risk analysis as to whether a tolerable risk has been achieved

NOTE See ISO/IEC Guide 51.

3.11
risk assessment

overall process of risk analysis and risk evaluation

NOTE See ISO/IEC Guide 51.

3.12

reliability

ability to perform a required function under specified conditions and for a given period of time without failing

3.13

pressure limiter

device which ensures that the permitted maximum allowable pressure is not exceeded during continuous operation

NOTE It activates the means for correction, or provides for shutdown or shutdown and lockout.

3.14

safety

freedom from unacceptable risk

NOTE See ISO/IEC Guide 51.

3.15

maximum allowable pressure

P_S

maximum pressure for which the equipment is designed, as specified by the manufacturer

3.16

maximum/minimum allowable temperature

T_S

maximum/minimum temperatures for which the equipment is designed, as specified by the manufacturer

3.17

accumulated pressure

pressure in the equipment to be protected which can exceed maximum allowable pressure for a short duration during the operation of safety devices

3.18

maximum allowable accumulated pressure

$P_{S,accum}$

maximum allowable value of the accumulated pressure in the equipment being protected which is fixed by national codes, regulations or directives

4 Risk consideration

4.1 All service conditions shall be considered when selecting the most appropriate safety concept, in order to ensure safe operation of the pressure equipment. This requires a realistic assessment of risk by means of risk analysis and risk evaluation.

4.2 Risk analysis involves, for example:

a) determination of the boundaries of the pressure equipment, including:

- 1) maximum quantity of fluid to be discharged,
- 2) intended use,
- 3) reasonably foreseeable misuse,
- 4) influences of sizing and flow of the safety device on operational reliability and performance of the safety system;

b) identification of potential hazards and estimation of the risk.

4.3 In particular, the risk analysis shall take in consideration the following:

- a) equipment connected together by piping of adequate capacity, which is free from potential blockages and does not contain any valve that can isolate any part, may be considered as a system of pressurized components for the application of pressure relief;
- b) where a component failure during operation is foreseen and would cause the pressure of fluid in the vessel to exceed the maximum allowable pressure, this failure shall be considered when evaluating the total capacity of the safety device(s);
- c) vessels that are to operate completely filled with liquid and can be isolated shall be equipped with a safety device, unless otherwise protected against excessive pressure;
- d) in cases where excessive vacuum conditions can occur and the vessel is incapable of withstanding such conditions, a vacuum safety device shall be fitted to allow a suitable fluid to enter the vessel automatically, so as to prevent the allowable vacuum being exceeded.

4.4 Examples of foreseeable failure include

- a) failure of a heating coil, and
- b) tube failure in a shell and tube heat exchanger. The normal practice is to design the protective device, taking into account the breakage of one tube in a heat exchanger with flow occurring from both ends of the tube.

4.5 Risk evaluation involves the process in which, on the basis of risk analysis, judgement is made to achieve a tolerable risk.

NOTE It is advisable that the manufacturer and the user consider the most onerous conditions that can exist for pressure and temperature within the allowable limits.

4.6 Risk analysis and risk evaluation produce the basic information that is needed for the risk assessment to design correctly the pressure equipment and to select the most efficient safety device(s). The equipment shall be designed in order to:

- a) eliminate or reduce hazards;
- b) provide appropriate protection measures if the hazard cannot be eliminated;
- c) prevent the danger from misuse.

The manufacturer shall inform the user of residual hazards and indicate the appropriate special measures for the particular case.

5 Pressure limitation

5.1 General

5.1.1 Safety devices shall become operational such that during the period in which the devices operate, the pressure in the equipment shall not exceed the maximum allowable accumulated pressure.

5.1.2 During normal operation of the equipment, the pressure shall be limited to the maximum allowable pressure at the appropriate temperature.

5.1.3 Where, under reasonably foreseeable service conditions, the internal pressure can exceed the maximum allowable pressure, the pressure equipment shall be protected by means of at least one safety device of adequate capacity and capability.

5.1.4 The safety device(s) shall be sized to have the required discharge capacity at a pressure not higher than the maximum allowable accumulated pressure.

5.1.5 When calculating the capacity of a safety device, the actual pressure and temperature of the relieved fluid shall be used. The effect of back pressure on the discharge capacity shall also be taken into account.

5.1.6 Oversizing of a safety device could cause secondary problems (e.g. too much fluid released, instability). The selection of type, number, size or combination of safety devices shall be suitable and reliable for the process of pressure equipment to be protected. For the calculation of the pressure losses of the inlet and the outlet lines, see Clauses 6 and 7.

If more than one safety device is installed, a possible interaction shall be taken into account, i.e.:

- when connected to the same discharge system, back pressure may affect the opening of a safety device when others are already discharging;
- dynamic effects (e.g. mechanical forces, flow changes).

5.2 Setting of safety devices

5.2.1 Safety devices shall have a set pressure not exceeding the maximum allowable pressure (P_S) of the equipment to be protected, except as permitted in 5.2.2 and 5.2.3.

5.2.2 If the capacity is provided by more than one safety device, only one of the devices needs to be set at a pressure not exceeding P_S . The other device(s) may be set at a pressure not more than 5 % in excess of P_S (see example in Annex B). In these cases, it is necessary to use safety devices with certified overpressure lower than the maximum allowable accumulated pressure, in order to meet the requirements of 5.1.4. In some cases (e.g. fire), national codes may permit set pressures in excess of $1,05 \times P_S$.

5.2.3 If allowed by national regulations or directives, the safety device set pressure may be above P_S , but not exceeding $1,05 \times P_S$, provided that an additional pressure limiter is fitted to ensure that the permitted P_S is not exceeded during continuous operation. In these cases, it is necessary to use safety devices with certified overpressure lower than the maximum allowable accumulated pressure in order to meet the requirements of 5.1.4.

5.2.4 The pressure at which a safety device is set to operate shall take into account the effect of static head, of superimposed back pressure and whether this is constant or variable. The effect of static head shall not result in a set pressure above P_S .

5.2.5 In cases requiring safety devices certified for liquid service with an overpressure exceeding the difference between P_S and the maximum allowable accumulated pressure, the set pressure shall be set at a lower value than P_S in order to meet the requirements of 5.1.4.

NOTE Similar considerations can apply to vapour service at low pressure.

5.2.6 In the case of re-closing safety devices, the reseating pressure shall be above the normal operating pressure of the system (see Figures A.1 and A.2).

5.2.7 In the case of spring loaded valves, the operating pressure should be set as low as practical below the set pressure. Safety valves are normally leak tested at 10 % below set pressure and differentials between set and operating pressure should take this into account.

6 Inlet line

6.1 The inlet line shall be as short as practical in order to avoid the negative influence of dynamic effects and pressure losses.

The inlet line from the equipment to be protected to the safety device may affect the performance of the safety device (e.g. stability and capacity).

The nominal size of the inlet line shall not be less than that of the safety valve inlet, stand alone or in combination.

6.2 Unless otherwise specified by national codes or regulations, the inlet line shall be so designed that the total pressure drop to the valve inlet does not exceed 3 % of the set pressure of the safety device, or one third of the blowdown, whichever is less. For built up back pressure, see Clause 7.

NOTE This is based on the correlation of the settled pressure loss in the inlet line of 3 % relative to the standard blowdown of 10 %, which is approximately one third.

In all cases, the difference between blowdown and pressure drop to the valve inlet shall be at least 2 % of the set pressure.

6.3 Unless otherwise specified by national codes or regulations, the total inlet pressure drop (difference of stagnation pressures, i.e. non-recoverable losses) is calculated using the actual flowing capacity, which is the capacity of the safety device calculated using the certified coefficient of discharge, divided by the derating factor 0,9. The pressure drop shall include the effects of isolating valves, fittings and bursting disc safety devices.

The inlet pressure drop calculation shall not be done by using the required capacity of a safety valve.

NOTE It is advisable that isolating valves and fittings in the inlet piping to a safety device be of the full bore type. Pressure losses can be reduced by avoiding sharp edges in the pipe work or by enlarging the diameter.

6.4 In some installed configurations of pilot operated safety valves (POSV) and controlled safety pressure relief system (CSPRS), the pressure loss may exceed 3 %. Further analysis of the valve performance should be carried out to ensure the stable operation of the safety device. This analysis may result in the use of, for example, remote sensing lines, lowered closing sensing pressure.

If the pressure loss exceeds 3 %, it shall be taken into account in the calculation of mass flow or flow area.

For calculations of pressure loss, see Annex C.

7 Outlet line

7.1 Consideration shall be given to the possible effect of back pressure on the safety device set pressure, its discharge capacity and its operating characteristics. This back pressure may be built-up back pressure or superimposed back pressure, or created by a bursting disc safety device installed downstream from a safety valve.

The allowable back pressure, which is the sum of the built-up back pressure and the superimposed back pressure, is typically specified by the valve manufacturer or national code or regulation.

NOTE This allowable back pressure is usually given as a percentage of the difference between the set pressure and the superimposed back pressure. For example, if the built-up back pressure is to be limited to 15 %,

$$\frac{P_b - P_u}{P_{set} - P_u} = 0,15$$

where

P_b is the back pressure;

P_u is the superimposed back pressure;

P_{set} is the set pressure.

7.2 Unless otherwise specified by national codes or regulations, the outlet pressure is calculated using the flowing capacity, which is the capacity of the safety device calculated using the certified coefficient of discharge, divided by the derating factor 0,9. This calculation shall include the effects of isolating valves, fittings and bursting disc safety devices.

NOTE The flowing capacity is usually greater than the required capacity.

7.3 The influence of the back pressure may be reduced by the use of safety valves fitted with balanced bellows.

NOTE For further information on calculating built-up back pressures and a method for designing outlet pipe systems, see Annex D. Graphical solutions are provided for allowable built-up back pressures of 10 %, 15 %, 20 %, 30 % and 40 %.

If the superimposed back pressure on a conventional spring loaded safety valve is constant, the valve shall be set using the cold differential test pressure. If the superimposed back pressure is variable, its effects on the set pressure of the safety device may be minimized using balanced bellows.

7.4 The outlet line shall be as short as practicable and have a bore at least as large as the valve outlet.

Outlet lines should be designed to be free draining from the safety device to any collection system. For open or closed disposal systems, if the installation is such that liquid can collect on the discharge side of the valve disc, the valve or the outlet line shall be fitted with an adequate drain at the lowest point to prevent liquid accumulation, and precautions shall be taken (where necessary) to prevent freezing.

7.5 To prevent excessive reaction stresses being transmitted to the safety device, the outlet line shall be securely anchored and adequately supported. The system shall be sufficiently flexible to accommodate temperature changes.

NOTE 1 It is advisable that pipe forces do not induce stresses that can impair the operation or the leak tightness of the safety device.

NOTE 2 For the calculation of reaction forces, see Annex E.

7.6 Consideration shall be given to the possible effects of acoustic fatigue on the piping due to the noise level reached when the safety device discharges.

NOTE For the calculation of noise level, see Annex F.

The design of the outlet line (restrictions, bends, etc) should be such that the speed of the gas in the pipe is always less than sonic speed.

7.7 Safety devices shall discharge the fluid so that it will be safely disposed of. If this is directly into the atmosphere, it shall be clear of adjacent equipment and areas normally accessible to personnel.

If a silencer is provided, the effect of back pressure shall be taken into account. The silencer shall be so constructed as to prevent any blockage of flow passages due to, for example, corrosion deposits.

The outlets from individual safety devices may be combined in a manifold and into a common discharge pipe.

8 Installation

8.1 General

Safety devices shall be so installed as to preclude injury to personnel by the relieving process. The discharge shall be piped to a safe location. The effects of the discharge and noise on the environment shall be considered.

Where there is a possibility of a liquid head forming in the discharge pipe, a drain shall be provided and lead to a safe location.

If discharge pipes are fitted with components to prevent ingress of rainwater or foreign bodies, these components shall not obstruct the free and full discharge of the safety devices.

Due consideration shall be taken of climatic, process or other conditions which might adversely affect the performance of the safety device.

If the safety device discharges a flammable fluid, the danger of ignition shall be considered and appropriate measures taken to reduce the risk to an acceptable level.

8.2 Installation of safety valves or the main valve of a CSPRS or a POSV

8.2.1 General

Bolting and gaskets shall be in accordance with relevant standards. Gaskets shall be of the correct type, material and dimensions and shall not obstruct any part of the bore of inlet or outlet lines.

Consideration shall be given to the aspects listed below.

- a) **External loads:** the inlet and outlet piping shall be supported to ensure that no unacceptable external mechanical loads are transmitted to the safety valve or the main valve providing the safety function. Especially for spring loaded safety valves, the effects on seat tightness shall be considered. In addition, the inlet and outlet piping shall be sufficient to withstand the effects of the reaction forces when the valve discharges.
- b) **Thermal stresses:** provision shall be made to accommodate any thermal stresses induced in the inlet and outlet piping.
- c) **Vibration stresses:** vibration stresses, including those caused by poor flow geometry in the inlet and/or the outlet piping systems, shall be minimized to avoid leakage across the seat of the safety valve and fatigue failure of the valve and piping.

If valves are mounted in other than a vertical position, the valve manufacturer's recommendations shall be considered.

Sufficient access and workspace, including height, shall be provided for the servicing and removal of safety devices.

8.2.2 Location

If a vessel contains both liquid and gas/vapour, and gas/vapour is to be relieved, a safety device for use with gases shall be connected to the vessel in the gas space, or piping connected to this space, and located in a position chosen to minimize the entrainment of liquid when the valve discharges. Alternatively, if there is liquid to be relieved, a safety device for use with liquid shall be connected to the vessel or piping below the liquid level at a point chosen to prevent ingress of gas/vapour.

If either phase is to be relieved, a safety device suitable for either phase should be installed.

NOTE If two-phase flow is possible, see ISO 4126-10.

8.2.3 Sensing line

For safety devices incorporating sensing lines, the connection for the sensing line at the pressure source should be located at a suitable location where pulsation, vibrations and excessive inlet pressure losses are minimized. Within this constraint, care should be taken to minimize the length of the sensing line.

For the sizing and the configuration of the sensing line, the manufacturer of the safety device shall be consulted.

For flowing pilots, remote sensing lines shall be sized to limit the pressure losses to 3 % of the set pressure based on the maximum flow rate of the pilot.

Where applicable, the line may incorporate a siphon, stop valves and a test connection to enable checking of the pressure settings. At any time, whatever the configuration and the situation, it shall be possible to verify that the pilot is in operation. For stop valves in sensing lines, 8.4.2, 8.4.3 and 8.4.4 apply.

Whenever practical, the sensing line should be self-draining.

8.3 Installation of safety valves and bursting disc safety devices in series or parallel

8.3.1 A bursting disc safety device may be mounted in series with a safety valve, provided that:

- a) when applicable, the requirements in ISO 4126-3 are met;
- b) the opening provided through the disc after rupture is sufficient to prevent interference with the proper functioning of the safety device;
- c) non-fragmentable bursting discs are used as far as possible; if fragmentable bursting discs are used, it shall be ensured by appropriate provisions that fragments of the burst element cannot impair the functioning of the safety valve;
- d) the requirements of Clauses 6 and 7 are met.

8.3.2 Bursting disc safety devices may be installed on the outlet side of a safety valve provided that:

- a) the safety valve is so designed that it will open at its proper pressure setting regardless of any back pressure that can accumulate between the valve disc and the bursting disc safety device, or the space between the valve disc and the bursting disc safety device shall be vented or drained to prevent accumulation of pressure due to a small amount of leakage from the valve;
- b) the bursting pressure of the bursting disc safety device at the coincident disc temperature, plus any pressure in the outlet piping, shall not exceed the design pressure of the outlet portion of the safety valve and any pipe or fitting between the safety valve and the bursting disc safety device;
- c) the presence of the bursting disc safety device in the outlet side of a safety valve meets all the requirements of Clause 7.

8.3.3 When a bursting disc safety device is fitted in series with a safety valve, the space between them, whatever the distance, shall be fitted with a device to prevent a build up of pressure in the interspace or to provide a warning of pressurization, as appropriate.

8.3.4 For the installation of bursting disc safety devices installed in parallel with safety valves, see ISO 4126-6.

8.4 Isolation of safety devices

8.4.1 Basic requirement

The equipment shall be protected against excessive pressure at all times during operation.

There shall be no isolating valve in a pressure relief system, except for the cases in 8.4.2, 8.4.3 and 8.4.4.

8.4.2 Isolation of safety device(s) from the equipment to be protected

Isolation of safety device(s) from the equipment to be protected is permitted if the source of pressure, which could lead to an unsafe condition, is simultaneously isolated from the equipment to be protected. A typical arrangement is shown in Figure 2.

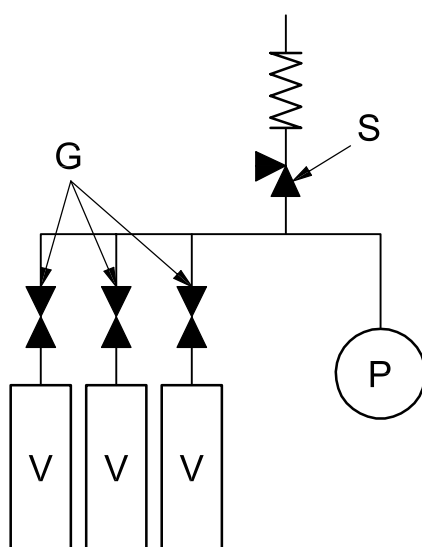

Key

- P pressure source
- V pressure vessel(s) to be protected
- S safety device(s)
- G isolating valves

Figure 2 — Illustration of one method of simultaneous isolation

Consideration shall be given to all other causes of pressure increase, such as solar radiation or fire.

Safety devices undergoing maintenance should be isolated from operating equipment. Operating equipment should continue to be fully protected against potential sources of overpressure.

8.4.3 Isolation of multiple safety devices

Any provision made for isolating any one safety device (e.g. for testing or servicing) shall ensure that the remaining safety device(s) connected to the equipment shall provide the full relief capacity required at any time.

Acceptable methods shall include:

- three-way valves;
- changeover valves;
- mechanical interlocks;
- captive sequential key interlocking.

8.4.4 Locking of isolating valve

All isolating valves in a pressure relief system (other than those in 8.4.2 and 8.4.3) shall be locked or sealed and regularly checked to ensure that they remain in the correct open or closed position.

8.4.5 Venting

A vent or bleed valve shall be fitted to the space between an isolating valve and the safety device, so that the space may be depressurized before commencing the removal of the device.

9 Lifting device

Safety valves for steam and compressed air duties may be provided with lifting (easing) gear, with the gear so arranged that the valves can be lifted positively off their seats when under operating pressure. In general, the lifting gear should be such that it cannot lock or hold the valve off its seat when the external lifting force is released.

For pressure equipment containing fluids which might create a hazard, lifting gear should not be provided.

Annex A (informative)

Safety device applications

% of maximum allowable pressure, P_S

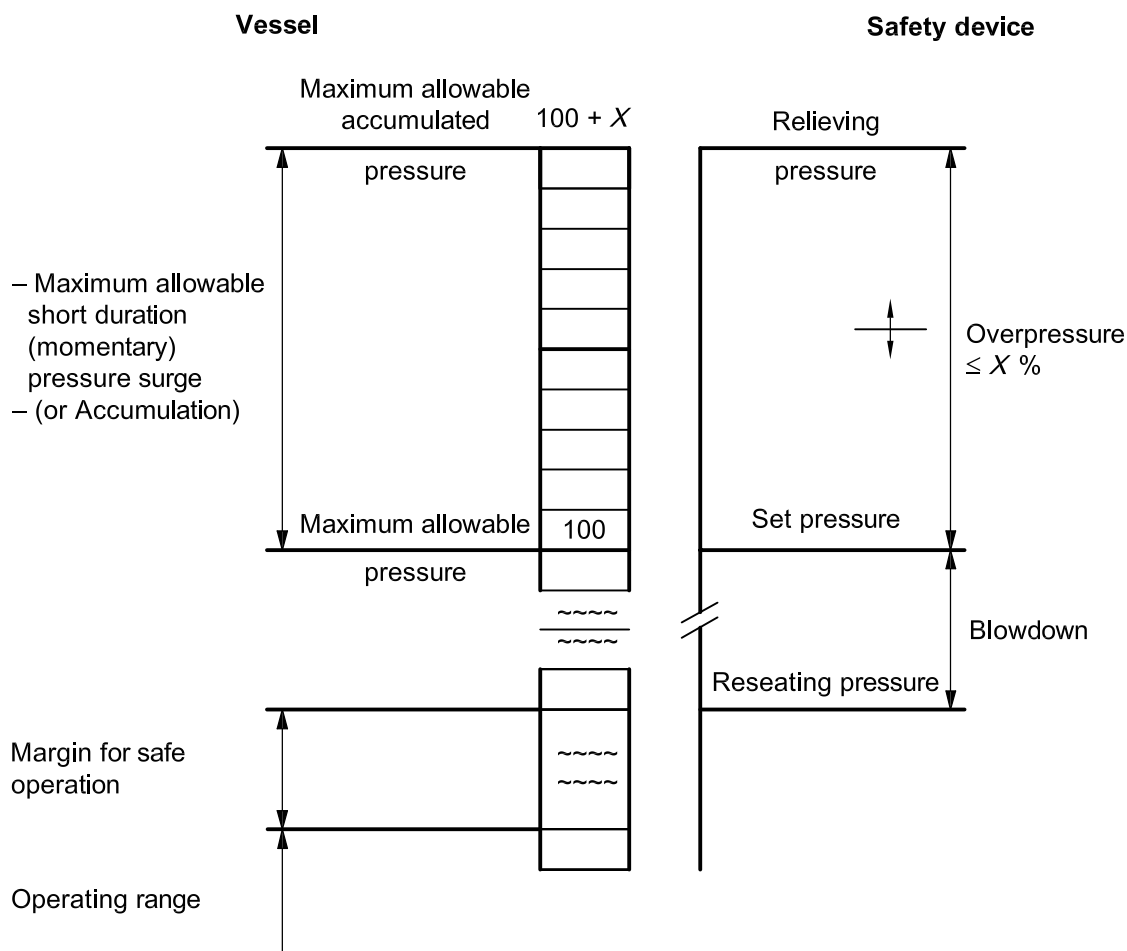
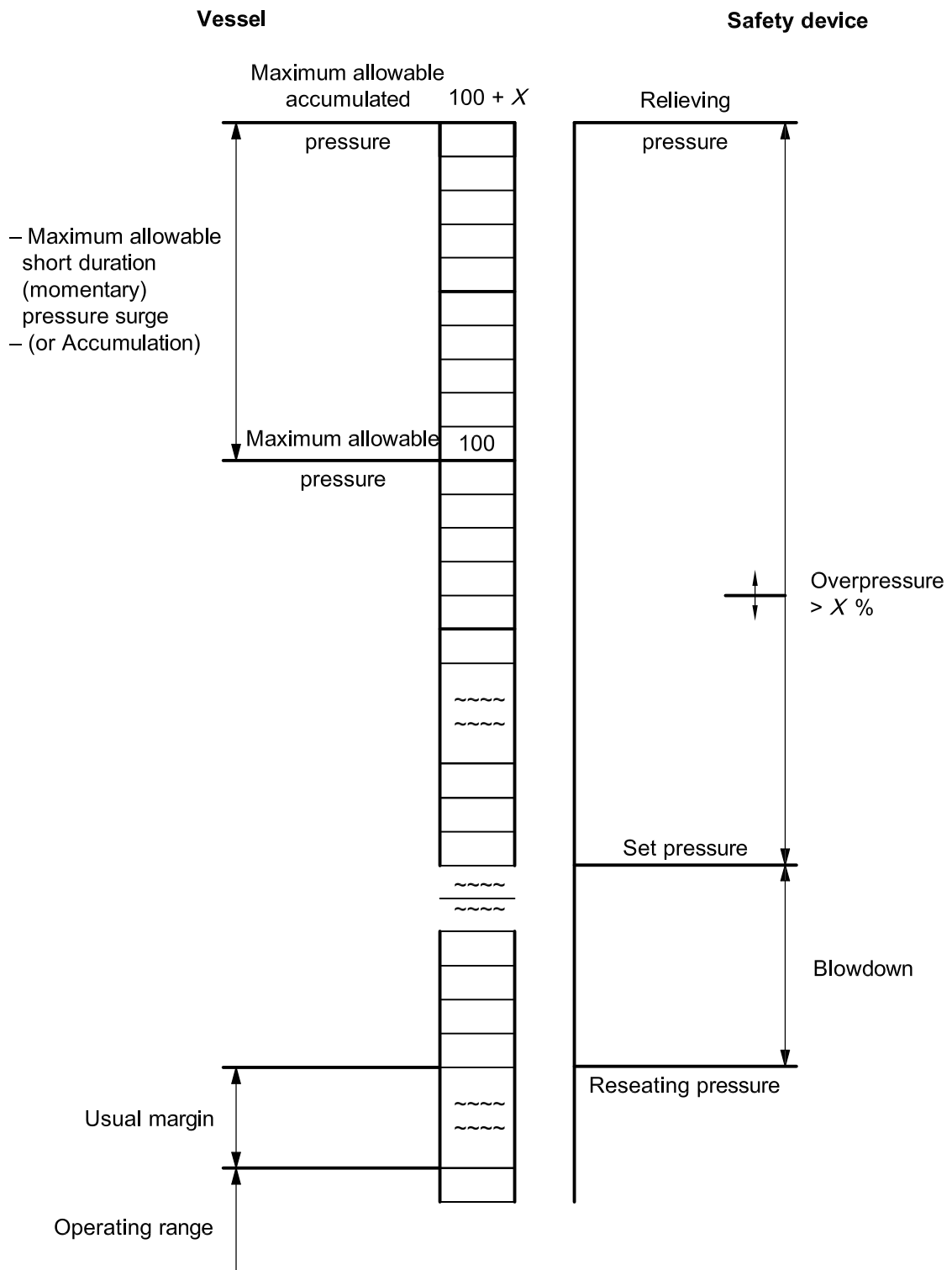
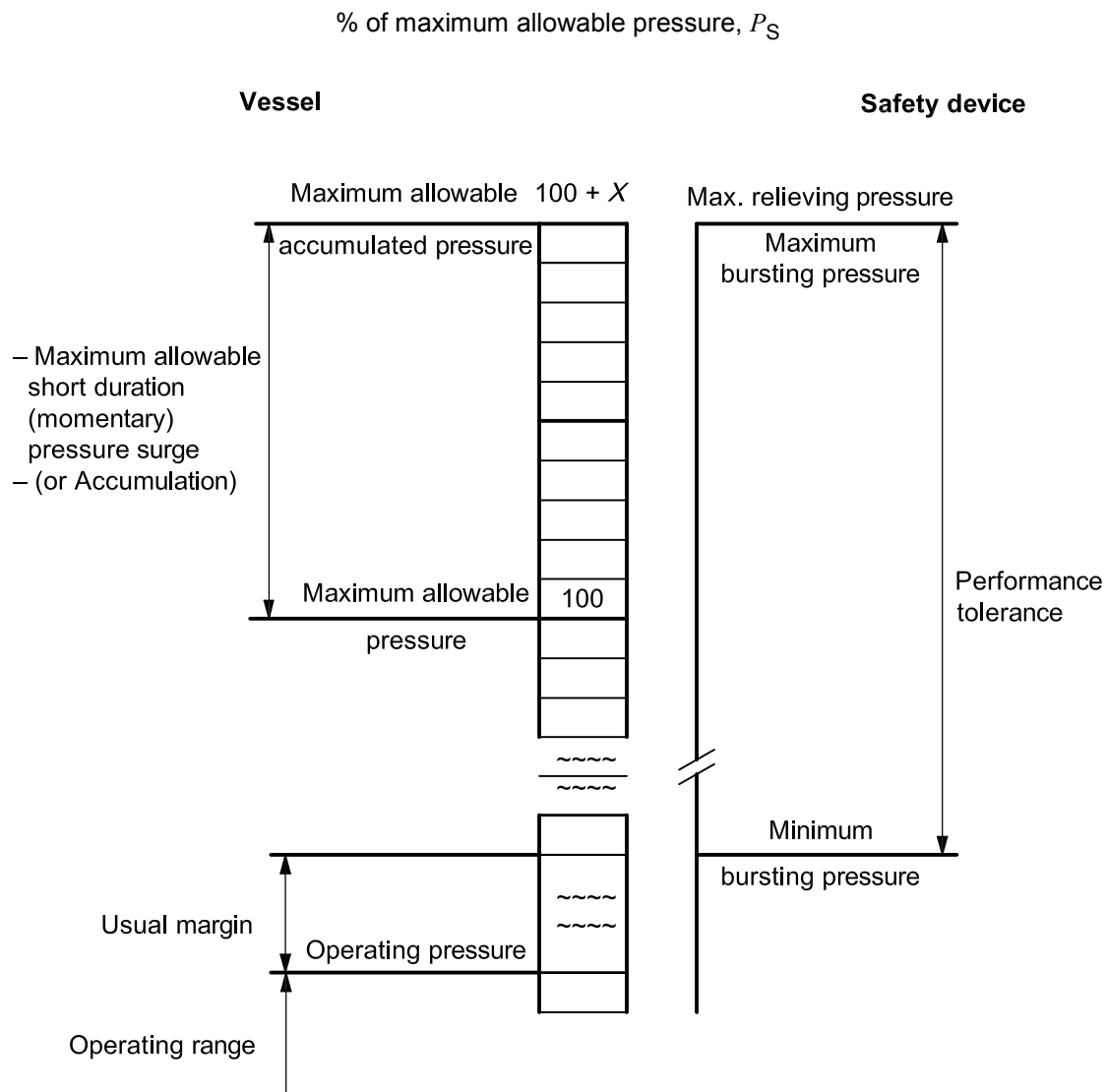

Figure A.1 — Safety valve applications — Safety valve certified at X % overpressure or less

% of maximum allowable pressure, P_S



**Figure A.2 — Safety valve applications —
 Safety valve attaining rated lift at more than X % overpressure**



Provision should be made to ensure that the operating pressure does not permanently exceed P_S

**Figure A.3 — Bursting disc safety device in combination with safety valves
 (less than or equal to X % overpressure)**

Annex B (informative)

Sizing of multiple safety devices

When more than one safety valve is fitted to a pressurized system, or part of a pressurized system, the relieving capacity of all of the safety valves should be calculated for the same relieving pressure, which is $(1 + x) \times P_S$. If all the valves are discharging, then the actual relieving pressure will be the same and will not be the individual set pressure plus some national regulated overpressure.

As an example, we can assume that the maximum allowable accumulated pressure is $1,10 \times P_S$.

NOTE The stability of safety valve performance in some multiple valve installations can depend on the storage capability (i.e. volume) of the equipment and can typically be improved by staggering the set pressures of the valves whenever practical. In some situations, calculation can be used to estimate an appropriate value by which the set pressures should be staggered.

The **maximum relieving pressure** to be used in the capacity calculations will therefore be the value of $1,1 \times P_S$.

The **maximum set pressure** will depend upon the overpressure that was adopted during the tests to determine the coefficient of discharge, K_d , of the valve. Valves can be used at a greater overpressure than that used during the test, but never at a lower overpressure.

Many existing valves have a coefficient of discharge which has been determined at an overpressure of 10 %, so these valves could never have a set pressure greater than P_S . In this "safety Systems" series of standards, there is a possibility of having a set pressure greater than P_S , providing that the valves can attain the certified capacity at significantly less than 10 % overpressure, and the relieving pressure remains within $1,1 \times P_S$. In other words, in order to be able to take advantage of this, the safety valves will have to be chosen before deciding the design pressure of the equipment, if the usual margin between the actual working pressure (including the normal deviations) and the lowest set pressure is to be maintained.

EXAMPLE 1 A vessel with a maximum allowable pressure of 10 MPa¹⁾ and a maximum allowable accumulated pressure of 11 MPa, fitted with three valves all having a K_d determined at 10 % overpressure, could have the valves set differently, as shown in Table B.1.

Table B.1 — Actual overpressures in a multi-valve installation — Example 1

Valve no.	Set pressure MPa	Relieving pressure MPa	Actual overpressure %
1	9,78	11	12,5
2	9,91	11	11,0
3	10	11	10,0

EXAMPLE 2 A vessel with a maximum allowable pressure of 10 MPa and a maximum allowable accumulated pressure of 11 MPa, fitted with three valves all having a K_d determined at 5 % overpressure, could have the valves set differently, as shown in Table B.2.

1) 1 bar = 100 kPa = 0,1 MPa.

Table B.2 — Actual overpressures in a multi-valve installation — Example 2

Valve no.	Set pressure MPa	Relieving pressure MPa	Actual overpressure %
1	10	11	10
2	10,2	11	8
3	10,48	11	5

In the above examples, the maximum relieving pressure is the same, i.e.

$$1,1 \times P_S$$

where

P_S is the maximum allowable pressure for the equipment.

The basic rule is as follows.

The relieving pressure used to calculate the minimum flow area through a safety pressure relief device shall always be $1,10 \times P_S$ given that the accumulation is specified at $1,1 \times P_S$.

Since the relieving devices will be available in discrete sizes, it is unlikely that there will be an exact match and, consequently, the flow area will be somewhat greater than the minimum. This means that the maximum pressure will not be greater than $1,10 \times P_S$.

The valve design and test conditions used to determine K_d will determine the maximum set pressure of any valve.

Annex C (informative)

Sizing of inlet lines

C.1 General

This annex presents a method for sizing inlet piping systems of safety devices to obtain acceptable inlet pressure losses. It is applicable to steam, gas and liquid.

C.2 Symbols and units

For the purposes of this annex and Annexes D, E and F, the symbols and units given in Table C.1 and Figure C.1 apply.

Table C.1 — Symbols and units

Symbol	Definition	Unit
A	Flow area of a safety valve (not curtain area)	mm ²
A_A	Flow area of outlet pipe	mm ²
A_E	Inlet pipe cross-section	mm ²
d	General internal pipe diameter	mm
d_A	Internal diameter of outlet pipe	mm
d_E	Internal diameter of inlet pipe	mm
F	Reaction force	N
k	Isentropic exponent	—
K_d	Coefficient of discharge	—
K_{dr}	Certified derated coefficient of discharge ($K_d \times 0,9$)	—
L_E	Developed length of inlet pipe	mm
P_0	Relieving pressure	MPa abs
P_b	Back pressure	MPa abs
P_{set}	Set pressure	MPa abs
P_u	Pressure at outlet of pipe end: superimposed back pressure, often atmospheric	MPa abs
ΔP_E	Pressure loss in inlet line	MPa
Q_m	Mass flow	kg/h
r	Pipe bend radius	mm
R_m	Equivalent roughness	mm
T	Temperature of fluid	K
u	Velocity of fluid in outlet pipe	m/s
v	Specific volume	m ³ /kg
λ	Pipe friction factor	—
ζ_l	Resistance coefficient for pipe and assembly parts	—
ζ_z	Allowable resistance coefficient	—

NOTE The unit used for set pressure in this annex and in Annexes D, E and F of this part of ISO 4126 is different from that specified in ISO 4126-1:2004, 3.2.1 (i.e. MPa abs instead of MPa gauge), for reasons of simplification in the formulae.

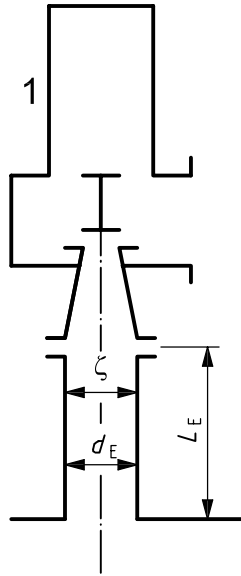

- Key**
- 1 safety device
 - d_E internal diameter of inlet pipe
 - L_E developed length of inlet pipe
 - ζ resistance coefficient

Figure C.1 — Safety device with inlet pipe

C.3 Sizing of inlet lines

By means of the diagram in Figure C.2, the allowable resistance coefficient, ζ_z , of the inlet pipe, and thus its maximum L_E , can be determined for a pressure loss of 3 % in safety device inlet pipes.

With the sum of the resistance coefficients ζ_1 (see Table C.3) of the individual pipe and assembly parts, as well as with the resistance coefficient of the straight pipe $\lambda \times \left(\frac{L_E}{d_E}\right)$, it is possible to calculate the allowable pipe length, L_E , with λ taken from Table C.2, as follows:

$$L_E = (\zeta_z - \sum \zeta_1) \times \frac{d_E}{\lambda}$$

With reference to Clause 6, the pressure drop in the inlet pipe shall not exceed 3 %. Where a longer length of pipe has to be used which increases the pressure drop to above 3 %, the effective pressure drop shall be determined and the size of the safety device shall be increased, if necessary, to ensure that the required mass flow can be achieved.

Table C.2 — Pipe friction factors λ for $R_m = 0,07$ mm (guide value)

Diameter, d mm	20	50	100	200	500
Pipe friction factor λ^a	0,027	0,021	0,018	0,015	0,013
$a \quad \lambda = \left(-2,0 \log \frac{R_m / d_E}{3,71} \right)^{-2}$					

Table C.3 — Resistance coefficients, ζ

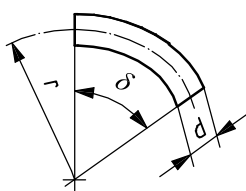
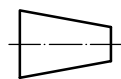
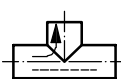
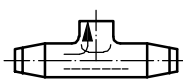
Pipe bend						
	$\frac{r}{d}$	Resistance coefficient ζ_1 for diameter d equal to				
		mm				
		20	50	100	200	500
For $\delta = 90^\circ$, $\zeta_{1,\delta=90}$ from table	1,0	0,42	0,33	0,27	0,24	0,19
	1,25	0,35	0,28	0,23	0,20	0,16
	1,6	0,29	0,23	0,19	0,17	0,14
	2	0,25	0,19	0,16	0,14	0,12
	2,5	0,22	0,17	0,15	0,13	0,10
	3,15	0,20	0,15	0,13	0,11	0,10
	4	0,18	0,14	0,12	0,10	0,10
	5	0,16	0,12	0,10	0,10	0,10
	6,3	0,14	0,11	0,10	0,10	0,10
	8	0,12	0,10	0,10	0,10	0,10
	10	0,14	0,11	0,10	0,10	0,10
For $\delta \neq 90^\circ$, $\zeta_{1,\delta \neq 90} = \zeta_{1,\delta=90} \sqrt{\frac{\delta}{90^\circ}}$						
Inlet pipe nozzle						
	Description	Resistance coefficient, ζ_1				
	well rounded	0,1				
	edge normally cut	0,25				
	sharp edge or set-through pipe	0,50				
Continuous reduction of cross-section						
	Description	Resistance coefficient, ζ_1				
	referred to reduced cross-section	0,1				
Right-angle tees						
	Description	Resistance coefficient, ζ_1				
	nozzle protruding in the run with sharp edges in the branch	0,35 ^b 1,28 ^b				
	nozzle extruded or set-on in the run	0,2 ^b				
	inlet rounded off ^a in the branch	0,75 ^b				
Change-over valves, locking devices						
	Determination of ζ value required.					
NOTE Guide values taken from AD 2000-Merkblatt A 2 ^[9] and TRD 421 ^[10] .						
^a For extended tees usual in high-pressure piping.						
^b Referred to stagnation pressure in inlet line of the safety device.						

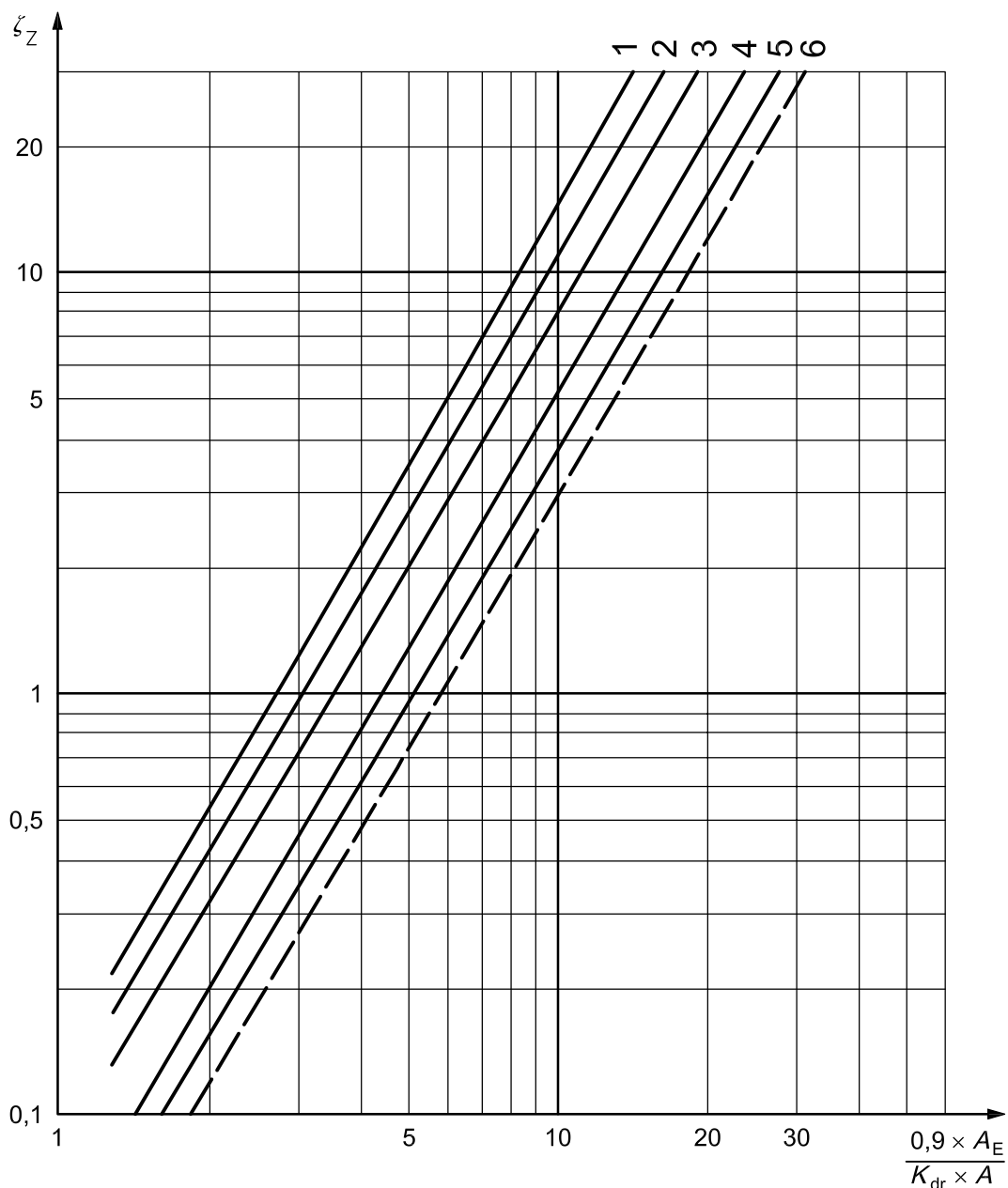

Key

- | | | | |
|---|-----------------|-----------|--|
| 1 | $P_b/P_0 = 0$ | P_b | back pressure |
| 2 | $P_b/P_0 = 0,2$ | P_0 | relieving pressure |
| 3 | $P_b/P_0 = 0,4$ | A | flow area of a safety valve |
| 4 | $P_b/P_0 = 0,6$ | A_E | inlet pipe cross-section |
| 5 | $P_b/P_0 = 0,8$ | K_{dr} | certified derated coefficient of discharge |
| 6 | $P_b/P_0 = 1,0$ | ζ_z | allowable resistance coefficient |

NOTE See AD 2000-Merkblatt A 2^[9].

**Figure C.2 — Allowable resistance coefficient (at $k = 1,3$)
 for inlet pressure loss equal to 3 % of set pressure**

In place of Figure C.2, the following formulae can be used.

— For **steam and gas**:

$$\zeta_z = \frac{1}{k} \times \left[C \times \left(\frac{0,9 A_E}{K_{dr} \times A} \right)^2 - 1 \right] \times \alpha \times \left(1 + \frac{3}{2} \alpha + 2\alpha^2 \right)$$

$$\alpha = 0,03 \times \left(1 - \frac{P_b}{P_0} \right)$$

$$C = 2 \times \left(\frac{k+1}{2} \right)^{\frac{k+1}{k-1}} \text{ for } \frac{\beta}{1-\alpha} \leq \left(\frac{2}{k+1} \right)^{\frac{k}{k-1}} \text{ (critical flow)}$$

or

$$C = \frac{k-1}{\left(\frac{\beta}{1-\alpha} \right)^{\frac{2}{k}} - \left(\frac{\beta}{1-\alpha} \right)^{\frac{k+1}{k}}} \text{ for } \frac{\beta}{1-\alpha} > \left(\frac{2}{k+1} \right)^{\frac{k}{k-1}} \text{ (sub-critical flow)}$$

where

$$\alpha = \frac{\Delta P_E}{P_0} \text{ is the ratio of inlet pressure loss to relieving pressure;}$$

$$\beta = \frac{P_b}{P_0} \text{ is the ratio of absolute back pressure to relieving pressure.}$$

— For **liquid**:

$$\zeta_z = \frac{0,03}{0,97} \times \left(\frac{0,9 A_E}{K_{dr} \times A} \right)^2$$

NOTE By means of the factor 0,9, account is taken of the fact that the K_{dr} value is derated by 10 %.

Annex D (informative)

Calculation of built-up back pressure

The built-up back pressure P_b in the valve outlet is generated during discharge as a result of the resistance ζ_A of the discharge pipe with elbows, silencer or other fittings.

For **liquids**, the built up gauge pressure at the safety valve outlet ($P_b - P_u$) with reference to the differential pressure ($P_0 - P_b$) at the safety valve is:

$$\frac{P_b - P_u}{P_0 - P_b} = \zeta_A \times \left(\frac{K_{dr} A}{0,9 A_A} \right)^2$$

With increasing built-up back pressure, the pressure difference ($P_0 - P_b$) decreases in the case of liquids, and the mass flow is thus reduced. See Figure D.1.

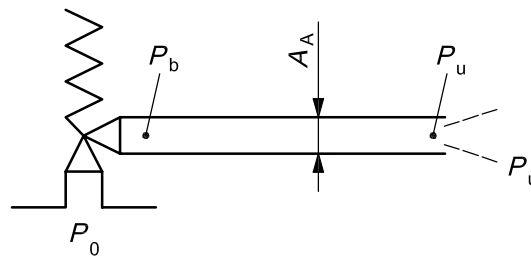

Key

- P_0 relieving pressure
- P_b back pressure
- P_u superimposed back pressure
- A_A flow area

NOTE The pressure at the end of the pipe is equal to the superimposed back pressure.

Figure D.1 — Case of liquids

As a condition for the admissible resistance coefficient of the discharge pipe, ζ_{AZ} , it follows that:

$$\zeta_{AZ} = \frac{P_b - P_u}{\frac{1}{2v} u^2}$$

For **gases and vapours**, with sufficiently strong expansion of the medium in the valve outlet, there will be a second critical flow condition at the end of the pipe with a “critical” outlet pressure, P_C , which is higher than the pressure at the outlet of the pipe, P_u . See Figure D.2.

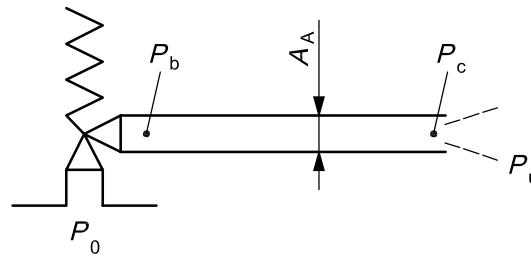

Key

- P_0 relieving pressure
- P_b back pressure
- P_c critical outlet pressure
- P_u superimposed back pressure
- A_A flow area

Figure D.2 — Case of steam, gases or vapours

The term “critical” condition means that the Mach number, Ma , is equal to 1, i.e. the flow velocity equals the sound velocity.

This is the case if the mass flow Q_m of the safety valve cannot be reached in the outlet area A_A at the density under ambient or superimposed back pressure P_u and with the maximum possible velocity, i.e. the sound velocity. The outlet pressure $P_c > P_u$ then generated is calculated as follows:

$$\frac{P_c}{P_0} = \left(\frac{2}{k+1} \right)^{\frac{k}{k-1}} \times \frac{K_{dr} \times A}{0,9 \times A_A}$$

Outlet pressure p_c and relieving pressure P_0 are absolute pressures.

A_A is the flow area of the discharge pipe which can be greater than or equal to the valve outlet area.

From the equation above, and with knowledge of the absolute relieving pressure, the absolute outlet pressure at the end of the pipe can be calculated.

If the calculated numerical value of the outlet pressure is smaller than P_u , there is no “critical” discharge and the outlet pressure is P_u .

The following diagrams give the allowable resistance coefficient ζ_A as a function of the ratio of the flow areas taking into account the discharge coefficient. Each curve in a diagram is valid for one ratio $\frac{P_u}{P_0}$.

Diagrams are given for allowable built-up back pressures of 10 %, 15 %, 20 %, 30 %, and 40 %. These diagrams have been developed for adiabatic compressible pipe flow of ideal gas with constant specific heat ratio (see for details Reference [11]).

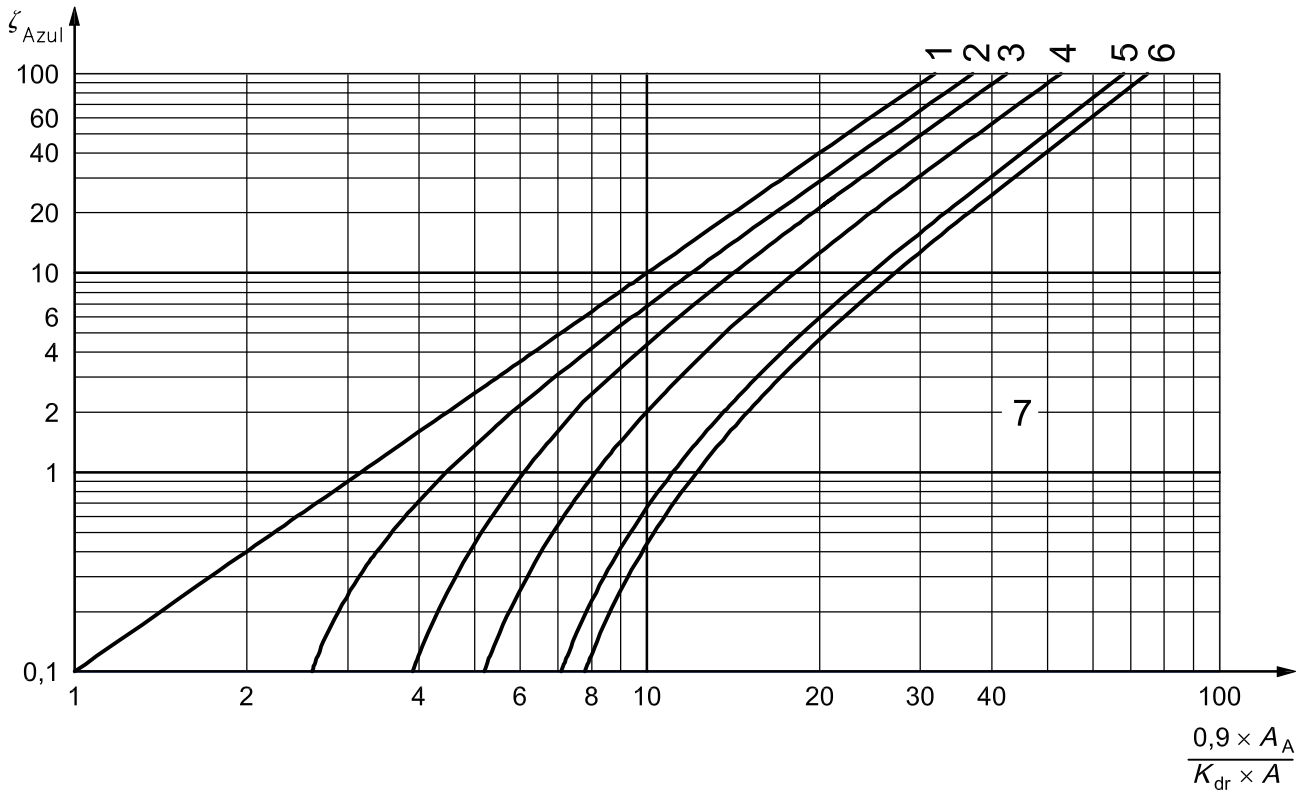

Key

- | | | | |
|---|--------------------------------|---|---|
| 1 | curve for liquids, limit value | $\frac{P_u}{P_0} = 1$ (100 kPa ^a) | A flow area of a safety valve |
| 2 | curve for compressible fluids | $\frac{P_u}{P_0} = 0,2$ (500 kPa ^a) | A_A flow area of outlet pipe |
| 3 | curve for compressible fluids | $\frac{P_u}{P_0} = 0,1$ (1 000 kPa ^a) | K_{dr} certified derated coefficient of discharge |
| 4 | curve for compressible fluids | $\frac{P_u}{P_0} = 0,05$ (2 000 kPa ^a) | P_u superimposed back pressure, usually atmospheric |
| 5 | curve for compressible fluids | $\frac{P_u}{P_0} = 0,01$ (10 000 kPa ^a) | P_0 vessel pressure abs ^a |
| 6 | curve for compressible fluids | $\frac{P_u}{P_0} = 0$ | ^a For $P_u = 0,1$ MPa abs. |
| 7 | compressible fluids | $\frac{P_u}{P_0} < 1$ | |

NOTE 1 The built-up back pressure, P_b , is equal to 10 % of the set pressure, P_{set} .

NOTE 2 The isentropic exponent, k , ranges between 1,2 and 1,6.

Figure D.3 — Allowable resistance coefficient, ζ_{Azul} , of the outlet line for 10 % built-up back pressure

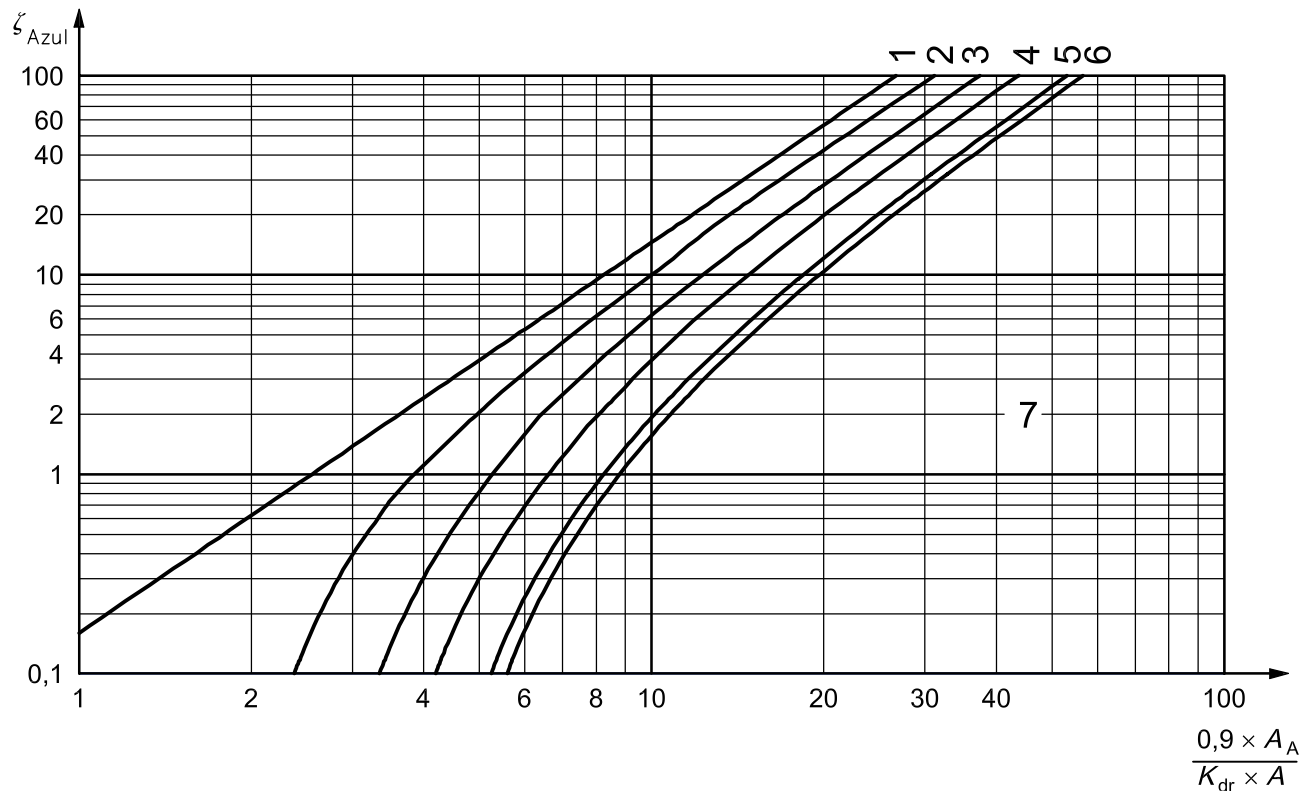

Key

- | | | | |
|---|--------------------------------|---|---|
| 1 | curve for liquids, limit value | $\frac{P_u}{P_0} = 1$ (100 kPa ^a) | A flow area of a safety valve |
| 2 | curve for compressible fluids | $\frac{P_u}{P_0} = 0,2$ (500 kPa ^a) | A_A flow area of outlet pipe |
| 3 | curve for compressible fluids | $\frac{P_u}{P_0} = 0,1$ (1 000 kPa ^a) | K_{dr} certified derated coefficient of discharge |
| 4 | curve for compressible fluids | $\frac{P_u}{P_0} = 0,05$ (2 000 kPa ^a) | P_u superimposed back pressure, usually atmospheric |
| 5 | curve for compressible fluids | $\frac{P_u}{P_0} = 0,01$ (10 000 kPa ^a) | P_0 vessel pressure abs ^a |
| 6 | curve for compressible fluids | $\frac{P_u}{P_0} = 0$ | ^a For $P_u = 0,1$ MPa abs. |
| 7 | compressible fluids | $\frac{P_u}{P_0} < 1$ | |

NOTE 1 The built-up back pressure, P_b , is equal to 15 % of the set pressure, P_{set} .

NOTE 2 The isentropic exponent, k , ranges between 1,2 and 1,6.

Figure D.4 — Allowable resistance coefficient, ζ_{Azul} , of the outlet line for 15 % built-up back pressure

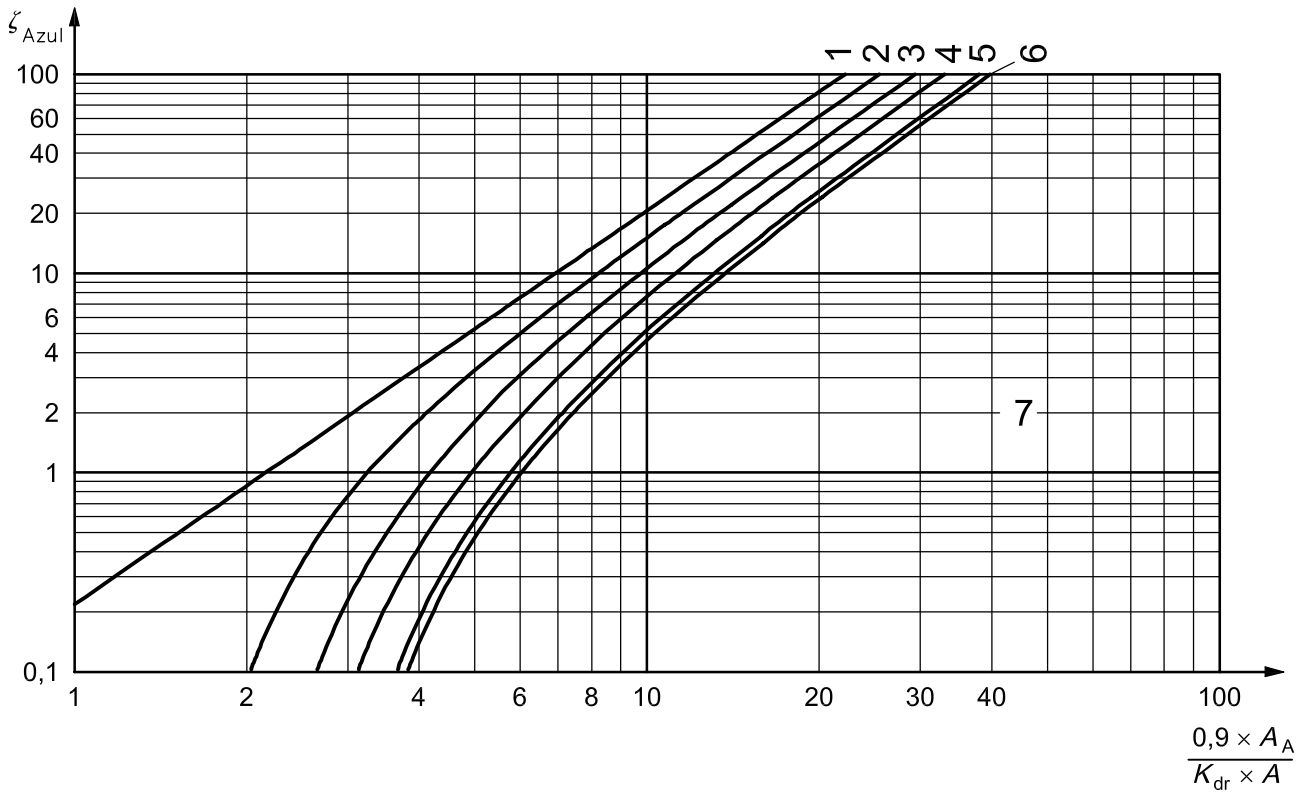

Key

- | | | | |
|---|--------------------------------|---|---|
| 1 | curve for liquids, limit value | $\frac{P_u}{P_0} = 1$ (100 kPa ^a) | A flow area of a safety valve |
| 2 | curve for compressible fluids | $\frac{P_u}{P_0} = 0,2$ (500 kPa ^a) | A_A flow area of outlet pipe |
| 3 | curve for compressible fluids | $\frac{P_u}{P_0} = 0,1$ (1 000 kPa ^a) | K_{dr} certified derated coefficient of discharge |
| 4 | curve for compressible fluids | $\frac{P_u}{P_0} = 0,05$ (2 000 kPa ^a) | P_u superimposed back pressure, usually atmospheric |
| 5 | curve for compressible fluids | $\frac{P_u}{P_0} = 0,01$ (10 000 kPa ^a) | P_0 vessel pressure abs ^a |
| 6 | curve for compressible fluids | $\frac{P_u}{P_0} = 0$ | ^a For $P_u = 0,1$ MPa abs. |
| 7 | compressible fluids | $\frac{P_u}{P_0} < 1$ | |

NOTE 1 The built-up back pressure, P_b , is equal to 20 % of the set pressure, P_{set} .

NOTE 2 The isentropic exponent, k , ranges between 1,2 and 1,6.

Figure D.5 — Allowable resistance coefficient, ζ_{AZUL} , of the outlet line for 20 % built-up back pressure

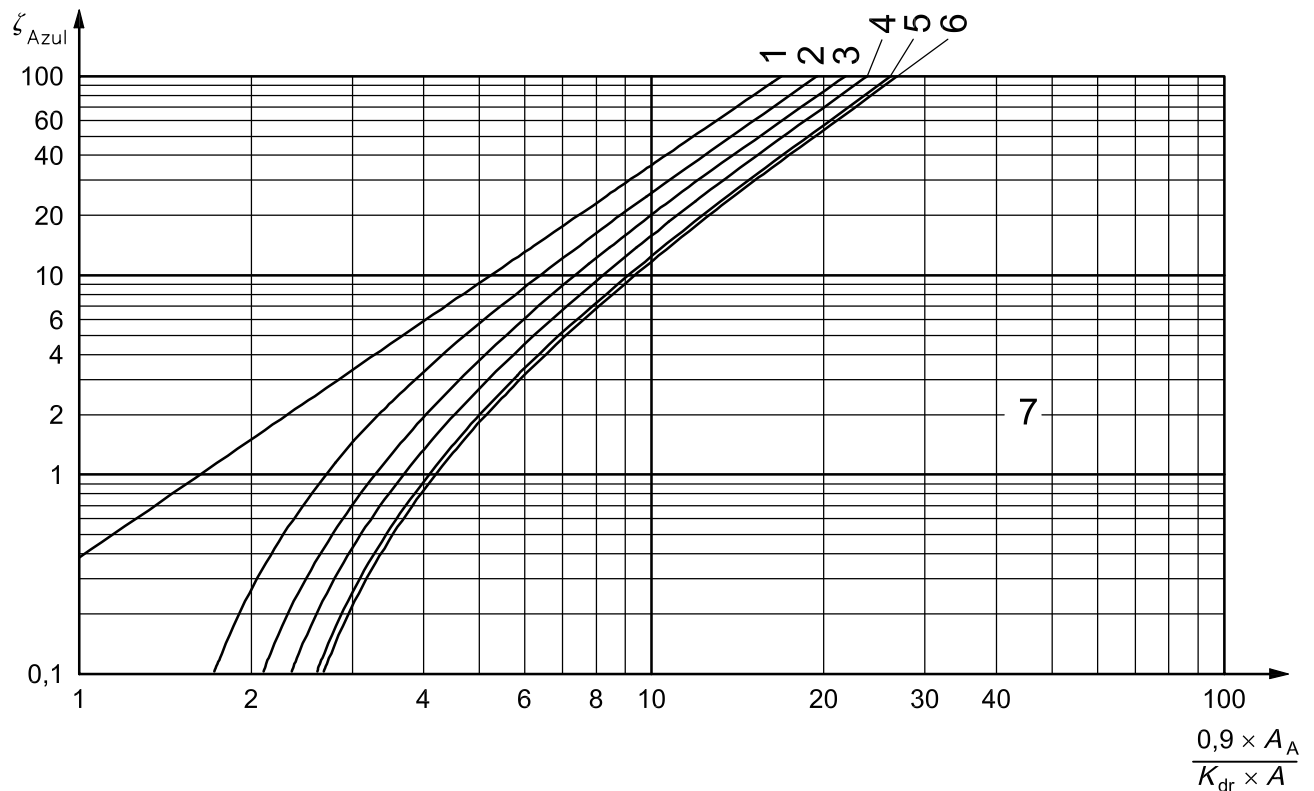

Key

- | | | | |
|---|--------------------------------|---|---|
| 1 | curve for liquids, limit value | $\frac{P_u}{P_0} = 1$ (100 kPa ^a) | A flow area of a safety valve |
| 2 | curve for compressible fluids | $\frac{P_u}{P_0} = 0,2$ (500 kPa ^a) | A_A flow area of outlet pipe |
| 3 | curve for compressible fluids | $\frac{P_u}{P_0} = 0,1$ (1 000 kPa ^a) | K_{dr} certified derated coefficient of discharge |
| 4 | curve for compressible fluids | $\frac{P_u}{P_0} = 0,05$ (2 000 kPa ^a) | P_u superimposed back pressure, usually atmospheric |
| 5 | curve for compressible fluids | $\frac{P_u}{P_0} = 0,01$ (10 000 kPa ^a) | P_0 vessel pressure abs ^a |
| 6 | curve for compressible fluids | $\frac{P_u}{P_0} = 0$ | ^a For $P_u = 0,1$ MPa abs. |
| 7 | compressible fluids | $\frac{P_u}{P_0} < 1$ | |

NOTE 1 The built-up back pressure, P_b , is equal to 30 % of the set pressure, P_{set} .

NOTE 2 The isentropic exponent, k , ranges between 1,2 and 1,6.

Figure D.6 — Allowable resistance coefficient, ζ_{AZUL} , of the outlet line for 30 % built-up back pressure at a safety valve with balanced bellows

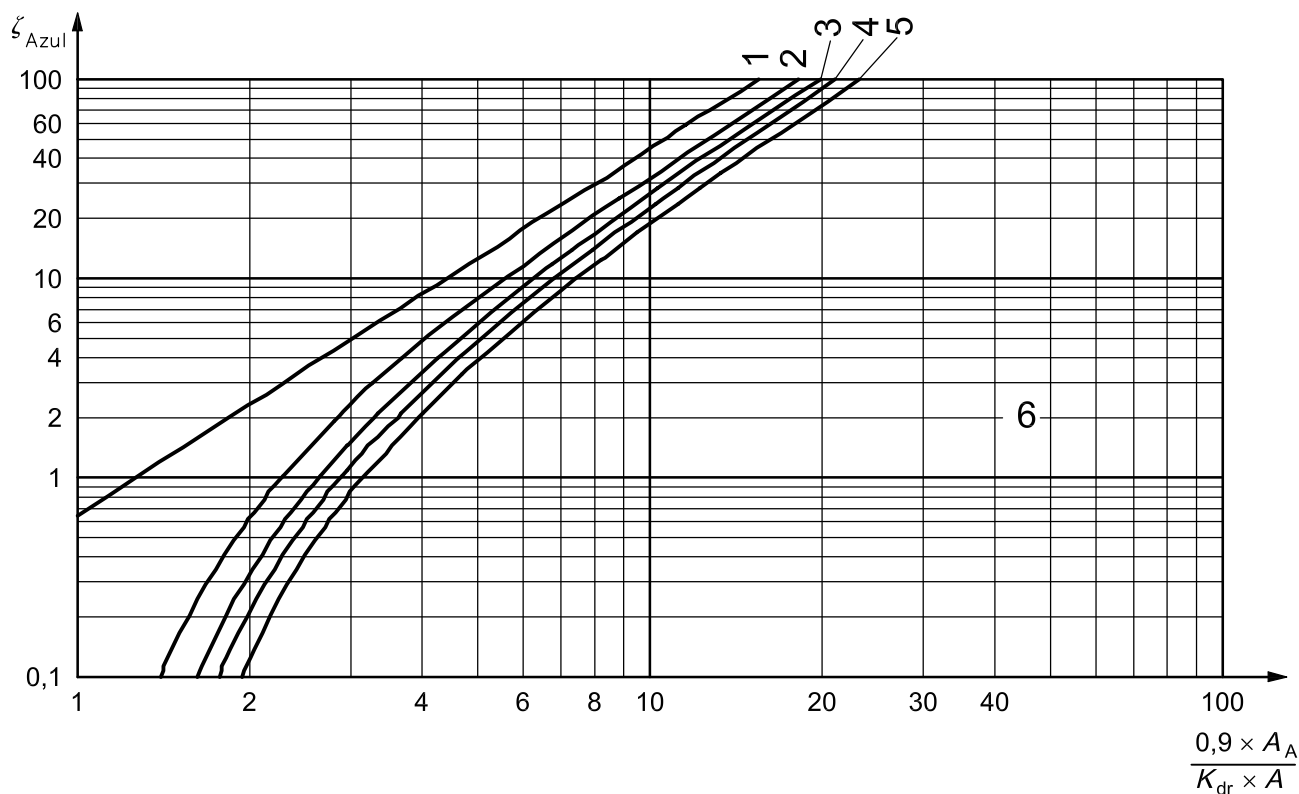

Key

- | | | | | | |
|---|--------------------------------|--------------------------|---------------------------|--------------|---|
| 1 | curve for liquids, limit value | $\frac{P_u}{P_0} = 1$ | (100 kPa ^a) | A | flow area of a safety valve |
| 2 | curve for compressible fluids | $\frac{P_u}{P_0} = 0,2$ | (500 kPa ^a) | A_A | flow area of outlet pipe |
| 3 | curve for compressible fluids | $\frac{P_u}{P_0} = 0,1$ | (1 000 kPa ^a) | K_{dr} | certified derated coefficient of discharge |
| 4 | curve for compressible fluids | $\frac{P_u}{P_0} = 0,05$ | (2 000 kPa ^a) | P_u | superimposed back pressure, usually atmospheric |
| 5 | curve for compressible fluids | $\frac{P_u}{P_0} = 0$ | | P_0 | vessel pressure abs ^a |
| 6 | compressible fluids | $\frac{P_u}{P_0} < 0$ | | ^a | For $P_u = 0,1$ MPa abs. |

NOTE 1 The built-up back pressure, P_b , is equal to 40 % of the set pressure, P_{set} .

NOTE 2 The isentropic exponent, k , ranges between 1,2 and 1,6.

Figure D.7 — Allowable resistance coefficient, ζ_{Azul} , of the outlet line for 40 % built-up back pressure at a safety valve with balanced bellow

Annex E (informative)

Calculation of reaction forces

When the safety device is closed, the loads resulting from the system pressure at the inlet and (if existing) superimposed back pressure are static and already taken into account when designing the pipework and selecting the safety device.

Reaction forces are forces generated when the valve is blowing. When the valve is open, the reaction forces are generated by the impulse of the flow and by built-up back pressure. At the inlet, the change of the forces is small. At the outlet, the reaction forces need to be considered, particularly for gaseous fluids, due to the high flow velocity and the increase of outlet pressure.

NOTE In many installations, the flow in the outlet is critical with speed of sound at a considerably higher back pressure than in the case of the closed valve.

When the safety valve is installed without a discharge pipe, the reaction force acts radial to the inlet axis. At steady flow, many forces will balance each other out. It should be noted that this balancing needs a certain time, depending on the opening time of the valve and the pressure wave propagation time. The transient forces can be reduced by minimizing the length of piping.

At steady flow, the reaction force, F , expressed in N, can be calculated, taking into account the conditions at the end of the piping, by the following equation:

$$F = \frac{Q_m \times u}{3\,600} + (P_b - P_u) \frac{A_A}{10}$$

where

Q_m is the mass flow, in kg/h;

u is the velocity of the fluid in the outlet pipe, in m/s;

P_b is the back pressure, in MPa abs;

P_u is the superimposed back pressure, in MPa abs;

A_A is the flow area of the outlet pipe, in mm².

Annex F (informative)

Calculation of noise level

The sound power level of the safety valve, P_{WL} , expressed in dB, can be estimated by the following equation:

$$P_{WL} = 20 \log(10^{-3} d_A) - 10 \log v + 80 \log u - 53$$

where

d_A is the internal diameter of outlet pipe, in mm;

v is the specific volume of the stream at relieving pressure and temperature, in m³/kg;

u is the velocity of fluid in outlet pipe, in m/s.

The sound pressure level, P_{SLr} , expressed in dB, at a distance r from the point of discharge to the atmosphere can be estimated by the following equation:

$$P_{SLr} = P_{WL} - 10 \log(2\pi r^2)$$

where r is the distance from noise source, in m.

Bibliography

- [1] ISO 4126-1:2004, *Safety devices for protection against excessive pressure — Part 1: Safety valves*
- [2] ISO 4126-2, *Safety devices for protection against excessive pressure — Part 2: Bursting disc safety devices*
- [3] ISO 4126-3, *Safety devices for protection against excessive pressure — Part 3: Safety valves and bursting disc safety devices in combination*
- [4] ISO 4126-4, *Safety devices for protection against excessive pressure — Part 4: Pilot-operated safety valves*
- [5] ISO 4126-5, *Safety devices for protection against excessive pressure — Part 5: Controlled safety pressure relief systems (CSPRS)*
- [6] ISO 4126-7, *Safety devices for protection against excessive pressure — Part 7: Common data*
- [7] ISO 4126-10, *Safety devices for protection against excessive pressure — Part 10: Sizing of safety valves and connected inlet and outlet lines for gas/liquid two-phase flow*
- [8] ISO/IEC Guide 51, *Safety aspects — Guidelines for their inclusion in standards*
- [9] AD 2000-Merkblatt A 2, *Safety devices against excess pressure — Safety valves*
- [10] TRD 421, *Safeguards against excessive pressure — Safety valves for steam boilers of groups I, III and IV*
- [11] ASCHER H. SHAPIRO, *The Dynamics and Thermodynamics of compressible Fluid Flow*, Vol. 1, The Ronald Press Company, New York, 1953

BSI - British Standards Institution

BSI is the independent national body responsible for preparing British Standards. It presents the UK view on standards in Europe and at the international level. It is incorporated by Royal Charter.

Revisions

British Standards are updated by amendment or revision. Users of British Standards should make sure that they possess the latest amendments or editions.

It is the constant aim of BSI to improve the quality of our products and services. We would be grateful if anyone finding an inaccuracy or ambiguity while using this British Standard would inform the Secretary of the technical committee responsible, the identity of which can be found on the inside front cover. Tel: +44 (0)20 8996 9000. Fax: +44 (0)20 8996 7400.

BSI offers members an individual updating service called PLUS which ensures that subscribers automatically receive the latest editions of standards.

Buying standards

Orders for all BSI, international and foreign standards publications should be addressed to Customer Services. Tel: +44 (0)20 8996 9001. Fax: +44 (0)20 8996 7001 Email: orders@bsigroup.com You may also buy directly using a debit/credit card from the BSI Shop on the Website <http://www.bsigroup.com/shop>

In response to orders for international standards, it is BSI policy to supply the BSI implementation of those that have been published as British Standards, unless otherwise requested.

Information on standards

BSI provides a wide range of information on national, European and international standards through its Library and its Technical Help to Exporters Service. Various BSI electronic information services are also available which give details on all its products and services. Contact Information Centre. Tel: +44 (0)20 8996 7111 Fax: +44 (0)20 8996 7048 Email: info@bsigroup.com

Subscribing members of BSI are kept up to date with standards developments and receive substantial discounts on the purchase price of standards. For details of these and other benefits contact Membership Administration. Tel: +44 (0)20 8996 7002 Fax: +44 (0)20 8996 7001 Email: membership@bsigroup.com

Information regarding online access to British Standards via British Standards Online can be found at <http://www.bsigroup.com/BSOL>

Further information about BSI is available on the BSI website at <http://www.bsigroup.com>

Copyright

Copyright subsists in all BSI publications. BSI also holds the copyright, in the UK, of the publications of the international standardization bodies. Except as permitted under the Copyright, Designs and Patents Act 1988 no extract may be reproduced, stored in a retrieval system or transmitted in any form or by any means – electronic, photocopying, recording or otherwise – without prior written permission from BSI.

This does not preclude the free use, in the course of implementing the standard, of necessary details such as symbols, and size, type or grade designations. If these details are to be used for any other purpose than implementation then the prior written permission of BSI must be obtained.

Details and advice can be obtained from the Copyright and Licensing Manager. Tel: +44 (0)20 8996 7070 Email: copyright@bsigroup.com