

BS ISO 4118:2016



BSI Standards Publication

Air cargo — Non-certified lower deck containers — Design and testing

National foreword

This British Standard is the UK implementation of ISO 4118:2016. It supersedes BS ISO 4118:2000 which is withdrawn.

The UK participation in its preparation was entrusted to Technical Committee ACE/57, Air cargo and ground support equipment.

A list of organizations represented on this committee can be obtained on request to its secretary.

This publication does not purport to include all the necessary provisions of a contract. Users are responsible for its correct application.

© The British Standards Institution 2016.
Published by BSI Standards Limited 2016

ISBN 978 0 580 81689 5

ICS 49.120; 55.180.30

Compliance with a British Standard cannot confer immunity from legal obligations.

This British Standard was published under the authority of the Standards Policy and Strategy Committee on 31 July 2016.

Amendments/corrigenda issued since publication

Date	Text affected
------	---------------

INTERNATIONAL
STANDARD

ISO
4118

Fourth edition
2016-07-01

**Air cargo — Non-certified lower deck
containers — Design and testing**

*Fret aérien — Conteneurs non-certifiés de pont inférieur —
Conception et essais*



Reference number
ISO 4118:2016(E)

© ISO 2016



COPYRIGHT PROTECTED DOCUMENT

© ISO 2016, Published in Switzerland

All rights reserved. Unless otherwise specified, no part of this publication may be reproduced or utilized otherwise in any form or by any means, electronic or mechanical, including photocopying, or posting on the internet or an intranet, without prior written permission. Permission can be requested from either ISO at the address below or ISO's member body in the country of the requester.

ISO copyright office
Ch. de Blandonnet 8 • CP 401
CH-1214 Vernier, Geneva, Switzerland
Tel. +41 22 749 01 11
Fax +41 22 749 09 47
copyright@iso.org
www.iso.org

Contents

Page

Foreword	v
Introduction	vi
1 Scope	1
2 Normative references	1
3 Terms and definitions	2
4 Dimensions and ratings	2
5 Design requirements	4
5.1 General.....	4
5.2 Base.....	5
5.3 Body.....	5
5.4 Doors.....	6
5.5 Internal tie-down.....	7
5.6 Placard holders.....	7
5.7 Design options.....	7
6 Flight conditions performance and testing	7
6.1 Pressure equalization and rapid decompression.....	7
6.2 Flight loads.....	7
7 Ground conditions performance and testing	9
7.1 General.....	9
7.2 Bridging and cresting.....	9
7.3 Impact test.....	9
7.4 Rain test.....	9
7.5 Racking test.....	10
8 Markings	10
9 Customs/security sealing (optional)	11
10 Manufacturer's instructions	11
11 Quality control	12
11.1 Design and production.....	12
11.2 Operations.....	12
Annex A (normative) Code DKC half-width contoured containers dimensions and design requirements	16
Annex B (normative) Code DKE/DKN half-width contoured containers dimensions and design requirements	18
Annex C (normative) Code DKP half-width rectangular containers dimensions and design requirements	20
Annex D (normative) Code DLF full-width contoured containers dimensions and design requirements	22
Annex E (normative) Code DLP full-width rectangular containers dimensions and design requirements	24
Annex F (normative) Code DPE/DPN half-width contoured containers dimensions and design requirements	26
Annex G (normative) Code DQF full-width contoured containers dimensions and design requirements	28
Annex H (normative) Code DQP full-width rectangular containers dimensions and design requirements	30

Annex I (normative) Code DAF full-width contoured containers dimensions and design requirements	32
Annex J (normative) Code DMF full-width contoured containers dimensions and design requirements	33
Annex K (normative) Code DKH low height full-width containers dimensions and design requirements	34
Annex L (normative) Code DKG low height half-width containers dimensions and design requirements	35
Bibliography	37

Foreword

ISO (the International Organization for Standardization) is a worldwide federation of national standards bodies (ISO member bodies). The work of preparing International Standards is normally carried out through ISO technical committees. Each member body interested in a subject for which a technical committee has been established has the right to be represented on that committee. International organizations, governmental and non-governmental, in liaison with ISO, also take part in the work. ISO collaborates closely with the International Electrotechnical Commission (IEC) on all matters of electrotechnical standardization.

The procedures used to develop this document and those intended for its further maintenance are described in the ISO/IEC Directives, Part 1. In particular the different approval criteria needed for the different types of ISO documents should be noted. This document was drafted in accordance with the editorial rules of the ISO/IEC Directives, Part 2 (see www.iso.org/directives).

Attention is drawn to the possibility that some of the elements of this document may be the subject of patent rights. ISO shall not be held responsible for identifying any or all such patent rights. Details of any patent rights identified during the development of the document will be in the Introduction and/or on the ISO list of patent declarations received (see www.iso.org/patents).

Any trade name used in this document is information given for the convenience of users and does not constitute an endorsement.

For an explanation on the meaning of ISO specific terms and expressions related to conformity assessment, as well as information about ISO's adherence to the World Trade Organization (WTO) principles in the Technical Barriers to Trade (TBT) see the following URL: www.iso.org/iso/foreword.html.

The committee responsible for this document is ISO/TC 20, *Aircraft and space vehicles*, Subcommittee SC 9, *Air cargo and ground equipment*.

This fourth edition cancels and replaces the third edition (ISO 4118:2005), of which it constitutes a complete technical revision.

Introduction

The basic functions of air cargo containers are

- a) the unitization of baggage, cargo or mail during ground handling and transportation, and
- b) the restraint in accordance with aircraft Weight and Balance Manual requirements of their contents against accelerations encountered in flight.

This revision introduces containers flight conditions testing in order to provide means to substantiate their ability to withstand maximum flight loads so that neither the container nor its contents can become a hazard or damage the aircraft structure.

Throughout this International Standard, the minimum essential criteria are identified by use of the key word "shall." Recommended criteria are identified by use of the key word "should" and, while not mandatory, are considered to be of primary importance in providing safe, economical and practical air transport containers. Deviation from recommended criteria should only occur after careful consideration and thorough service evaluation have shown alternate methods to provide an equivalent level of safety.

The requirements of this International Standard are expressed in the applicable SI units, with approximate inch-pound units conversion between brackets for convenience in those countries using that system. Where it is deemed necessary to use exact values, the SI unit ones are to be used, except for container base plan-view dimensions, whose exact values are those expressed in inches.

Air cargo — Non-certified lower deck containers — Design and testing

1 Scope

This International Standard covers the design, performance and testing requirements for lower deck containers for use in main line aircraft which do not require airworthiness approval/certification when loaded under the conditions of compartment restraint and/or where applicable according to the aircraft type's approved Weight and Balance Manual, ISO 8097 or ISO 21100 equivalent base plate restraint for these containers.

Aircraft Weight and Balance Manuals require non-certified containers be constructed then loaded in such a manner that neither the container nor its contents can become a hazard or damage the aircraft structure under flight conditions. Compliance with the present International Standard is one means of demonstrating compliance with these requirements.

Most sizes of containers covered by this International Standard (base sizes K, L, P and Q) cannot physically be loaded and latched on aircraft main deck cargo systems. Base size A and M containers can, but are not allowed on aircraft main decks, which in general do not accept non-certified units. Accordingly, all containers covered by this International Standard are intended to be used/installed exclusively in aircraft lower deck compartments

NOTE The metric equivalents for dimensions have been rounded up or down to the nearest millimetre, except in critical dimensions. Masses have been rounded up to the nearest kilogram and forces have been rounded up to the nearest 10 N. See introduction where it is deemed necessary to use exact values.

2 Normative references

The following documents, in whole or in part, are normatively referenced in this document and are indispensable for its application. For dated references, only the edition cited applies. For undated references, the latest edition of the referenced document (including any amendments) applies.

ISO 4116, *Air cargo equipment — Ground equipment requirements for compatibility with aircraft unit load devices*

ISO 7166, *Aircraft — Rail and stud configuration for passenger equipment and cargo restraint*

ISO 10046, *Aircraft — Methodology of calculating cargo compartment volumes*

ISO 10254, *Air cargo and ground equipment — Vocabulary*

ISO 11242, *Aircraft — Pressure equalization requirements for cargo containers*

ISO 21100, *Air cargo unit load devices — Performance requirements and test parameters*

CAAC CCAR-25, *Airworthiness Standards –Transport Category Airplanes, paragraph 25.855, Cargo or baggage compartments¹⁾*

U.S. Code of Federal Regulations 14 CFR Part 25, *Airworthiness Standards: Transport category airplanes, paragraph 25.855, Cargo or baggage compartments²⁾*

1) The Civil Aviation Administration of China (CAAC) CCAR-25 constitutes the Chinese government transport aircraft airworthiness Regulations.

2) 14 CFR Part 25 constitutes the U.S.A. Government transport aircraft airworthiness Regulations, and can be obtained from: US Government Printing Office, Mail Stop SSOP, Washington DC 20402-9328, U.S.A. or its web site at www.gpoaccess.gov. from: US Government Printing Office, Mail Stop SSOP, Washington DC 20402-9328, U.S.A. or its

European Aviation Safety Agency CS-25, *Certification Specifications for Large Aeroplanes, paragraph 25.855, Cargo or baggage compartments*³⁾

Japanese Airworthiness Standard Part 3 (Civil Aeronautics Law Article 10, paragraph 4)⁴⁾

3 Terms and definitions

For the purposes of this document, the definitions in ISO 10254 and the following apply.

3.1 aircraft container

completely enclosed unit load device which interfaces directly with the aircraft cargo handling and restraint system and alone performs all the functions of a unit load device

3.2 certification approval

approval by an airworthiness authority that a component or item of equipment meets the required performance for aircraft installation

3.3 non-certified container

container exclusively for the lower deck of wide-body aircraft, which is not subject to airworthiness approval (certification), but may be carried under conditions specified by the aircraft's Weight and Balance Manual

3.4 Weight and Balance Manual W&BM

manual published for each aircraft type by its manufacturer, which is approved by the airworthiness authority as part of the aircraft type's certification and defines the set of limits not to be exceeded by the operating carrier when loading

4 Dimensions and ratings

4.1 Containers complying with this International Standard are identified by a type code composed of three letters:⁵⁾

- a) the first letter **D** denoting a non-certified aircraft container;
- b) the second letter **A, K, L, M, P** or **Q** denoting the base size as defined in ISO 21100;
- c) the third letter denoting the contour determined in accordance with ISO 10046 (see NOTE).

website at www.gpoaccess.gov.

3) EASA CS-25 constitutes the European Governments transport aircraft airworthiness Regulations and can be obtained from: European Aviation Safety Agency (EASA), Postfach 101253, D-50452 Cologne, Germany, or its web site at www.easa.europa.eu.

4) Japanese Airworthiness Standard Part 3 (ISBN 4-89279-661-1) constitutes the Japanese government transport aircraft airworthiness Regulations, and can be obtained from the Civil Aviation Bureau (CAB) of the Ministry of Land, Infrastructure, Transportation and Tourism, Tokyo, Japan, or its website at www.mlit.go.jp/en.

5) The type code is, by industry consensus, under custody of and assigned by the International Air Transport Association (IATA), ULD Registrar, 800 Place Victoria, P.O. Box 113, Montréal, Québec H4Z 1M1, Canada, web site at www.iata.org.

The identification code shall be prominently marked on two opposite sides of the container (see [Clause 8](#)).

EXAMPLE

A non-certified aircraft container (D) of base size 3 175 mm x 1 534 mm (125 in x 60,4 in) (size L) and of nominal overall width 3 175 mm (125 in) (rectangular contour P) shall be designated as **DLP**.

NOTE The containers type code's third (contour) digit is subject to change to accommodate evolving airline needs. Check the latest yearly edition of IATA Unit Load Devices Regulations Standard Specifications 40/1 and 50/0 [Appendix E](#) (References [5] and [6]) for any code changes.

4.2 External contours, dimensions, and ratings of applicable containers are shown in [Table 1](#).

Table 1 — Ratings and contour dimensions of non-certified containers

Name of containers and nominal dimensions in mm (in)	Rating (Maximum operational gross mass) kg (lb) ^a	Contour and external dimensions	IATA Identification Code (IATA 40/1) ^b
Half-width contoured container, 2 337 mm (92 in) wide, with base dimensions 1 534 mm x 1 562 mm (60,4 in x 61,5 in)	1 588 kg (3 500 lb)	Annex A	DKC
Half-width contoured container, 2 007 mm (79 in) wide, with base dimensions 1 534 mm x 1 562 mm (60,4 in x 61,5 in)	1 588 kg (3 500 lb)	Annex B	DKE/DKN
Half-width rectangular container, 1 562 mm (61,5 in) wide, with base dimensions 1 534 mm x 1 562 mm (60,4 in x 61,5 in)	1 588 kg (3 500 lb)	Annex C	DKP
Full-width contoured container, 4 064 mm (160 in) wide, with base dimensions 1 534 mm x 3 175 mm (60,4 in x 125 in)	3 175 kg (7 000 lb)	Annex D	DLF
Full-width rectangular container, 3 175 mm (125 in) wide, with base dimensions 1 534 mm x 3 175 mm (60,4 in x 125 in)	3 175 kg (7 000 lb)	Annex E	DLP
Half-width contoured container, 1 562 mm (61,5 in) wide, with base dimensions 1 534 mm x 1 194 mm (60,4 in x 47 in)	1 225 kg (2 700 lb)	Annex F	DPE/DPN
Full-width contoured container, 3 175 mm (125 in) wide, with base dimensions 1 534 mm x 2 438 mm (60,4 in x 96 in)	2 449 kg (5 400 lb)	Annex G	DQF
Full-width rectangular container, 2 438 mm (96 in) wide, with base dimensions 1 534 mm x 2 438 mm (60,4 in x 96 in)	2 449 kg (5 400 lb)	Annex H	DQP
Full-width contoured container, 4 064 mm (160 in) wide, with base dimensions 2 235 mm x 3 175 mm (88 in x 125 in)	4 627 kg (10 200 lb)	Annex I	DAF
Full-width contoured container, 4 064 mm (160 in) wide, with base dimensions 2 438 mm x 3 175 mm (96 in x 125 in)	5 103 kg (11 250 lb)	Annex J	DMF
Low-height, full-width contoured container, 2 438 mm (96 in) wide, with base dimensions 1 534 mm x 1 562 mm (60,4 in x 61,5 in)	1 588 kg (3 500 lb) ^c	Annex K	DKH
Low-height, half-width contoured container, 2 007 mm (79 in) wide, with base dimensions 1 534 mm x 1 562 mm (60,4 in x 61,5 in)	1 588 kg (3 500 lb) ^c	Annex L	DKG
^a Actual maximum gross mass shall comply with the aircraft's Weight and Balance Manual.			
^b Carriage of non-certified containers in any cargo compartment must be allowed by the aircraft type's Weight and Balance Manual.			
^c Limited to 1 134 kg (2 500 lb) on the main aircraft types concerned.			

NOTE The maximum gross mass allowable for a non-certified container on any given position of an aircraft is determined by the aircraft type or sub-type's Authority-approved Weight and Balance Manual. Because this value is aircraft type dependent, airlines through IATA have agreed, principally for interlining purposes, to define for each ULD size a container maximum operational gross mass independent from the aircraft type, as shown in [Table 1](#), which is often higher or sometimes lower than the maximum allowable one on a given aircraft type.

5 Design requirements

5.1 General

5.1.1 Non-certified lower-deck containers shall meet the requirements of this International Standard and, in accordance with airworthiness Authority-approved aircraft Weight and Balance Manuals, be constructed then loaded in such a manner that neither the container nor its contents can become a hazard or damage the aircraft structure under flight conditions.

5.1.2 The container shall consist of a complete enclosure (base, top, four sides) with door.

5.1.3 The structure shall be designed to provide the maximum usable internal volume available within the limits of structural design and the space required for latching, including door(s).

5.1.4 Provisions shall be made for closing and sealing the container to meet customs clearance and security requirements (see [Clause 9](#)).

5.1.5 The tare weight of the container shall be kept to a minimum, consistent with the requirements and within the limits of sound design practice.

A direct environmental impact of containers use is that their weight results in additional fuel burn by aircraft. Therefore, apart from economic advantages, reducing containers weight as much as possible to still meet performance objectives is a highly effective environmental contribution and should be pursued.

5.1.6 If required (see [5.7](#)), means of fork-lifting the container shall be provided in accordance with the appropriate annexes.

5.1.7 Robustness, reliability and maintainability shall be major factors in the design, commensurate with planned service life.

5.1.8 The materials used shall be fire resistant, in accordance with the regulatory requirements of CS-25, CCAR-25, JAS Part 3 or 14 CFR Part 25 [Appendix F](#) Part I § (a)(2)(iv) and (a)(1)(v), i.e. may not have a burn rate greater than 100 mm (4 in) per minute when tested horizontally as specified in Part I § (b)(5).

5.1.9 During material selection, preference shall be given to recyclable materials and materials that minimize overall environmental impact, as well as carbon dioxide production, where this does not compromise container performance and weight. The container's components and materials should be selected in order to allow identified recycling methods when out of use. Instructions for recycling should be provided by the manufacturer (see 10.1).

5.1.10 No surfaces or edges shall present sharp or rough edges potentially injurious to personnel or cargo.

5.1.11 Insofar as atmospheric conditions may affect the performance of the container or any part thereof, it should be taken into account that during transportation, these conditions range from -40 °C (-40 °F) to 60 °C (140 °F) in temperature, with relative humidity from 20 % to 85 %. These are the mean temperature and humidity figures worldwide without taking into account extremes in temperature such as those experienced in arctic, sub-polar, or desert regions. This, however, is not a test requirement.

5.1.12 Component parts shall be replaceable by interchange with new or repaired ones. Panel assemblies should be replaceable by interchange with new or repaired ones.

5.2 Base

5.2.1 The base shall be smooth and free from rough or sharp edges which may be hazardous to personnel, cargo, aeroplane, ramp, and terminal handling equipment. The base shall be structurally attached to, and an integral part of, the container assembly. The construction shall be designed for strength and durability to withstand harsh treatment during its service life. It shall have a high resistance to impact and wear. Where attachment of the container body to the base is required, this should be accomplished by the use of normal hand tools.

5.2.2 Care shall be exercised in the design and construction of the base to ensure that flatness of the lower surface and edge members can be maintained in service and it is of adequate strength to minimize bowing and to provide for the ease of conveyance

5.2.3 The base's outer dimensions and tolerances shall be as defined for the relevant size in ISO 21100. All base edges, corners, and restraint space shall have dimensions as shown in [Figure 1](#) for sizes K, P and Q, or [Figure 2](#) for sizes A, L and M, and [Table 4](#). The recess over the base edge shall be maintained continuously all around the base periphery. The required minimum clearance shall be provided under the sloped (overhanging) panel on the outboard side(s).

5.2.4 The base design shall provide for support and ease of movement at the equally distributed rating on minimum conveyor systems as defined in ISO 4116. Its stiffness shall aim at not exceeding a maximum area load of 10 kPa (209 lbf/ft²) on the underlying conveying system. The minimum core stiffness of the base shall be

- 77 N.m²/m (680 lbf.in²/in) width/length of core for sizes K, P or Q,
- 330 N.m²/m (2 900 lbf.in²/in) width/length of core for all other sizes.

5.2.5 Where optional forklift capability is provided, the minimum forklift entry size should be 100 mm (4 in) high by 300 mm (12 in) wide, with chamfered protected edges.

5.2.6 Where provided, there shall be forklift entries at least on the two long sides, although three-way entry is preferred on K-size and P-size units.

5.2.7 On size L and size Q units, the distance between the inner edges of the optional forklift entries shall be not less than 815 mm (32 in), and on size K and size P units not less than 355 mm (14 in).

5.2.8 The optional base forklift tine entry and separation should be designed so that the base panel of the unit imparts no more than 10 kPa (209 lbf/ft²) to the supporting conveyor systems.

5.3 Body

5.3.1 It is essential that the container's integrity be maintained throughout its transportation because the container interfaces directly with the aircraft system. Imposed loads shall be sustained by the base and the body. The materials and methods of construction shall, therefore, be adequate for this task.

5.3.2 The sides, roof, and door(s) shall be of a minimum weight commensurate with maximum stability during both ground handling and air transportation.

5.3.3 Access for loading is generally required on one or both longer sides, although positions may vary to suit individual requirements.

5.3.4 The roof shall be flush, such that any protrusions do not cause damage in contact with the aircraft's cargo compartment ceiling. The top of the container shall be self-draining and designed for easy snow removal.

5.3.5 There shall be no intrusions between the base edges, as defined in [Figures 1](#) and [2](#) base details typical for all edges, and the container body within a depth of 28 mm (1,12 in) from the base edges.

5.3.6 In addition to those on the door (see 5.4.4), two non-protruding handles or straps shall be located on each side panel for manual handling of the container by one person. Each handle shall

provide 150 mm (6 in) wide by 75 mm (3 in) deep space for gripping with a gloved hand, and shall have a minimum capacity of 445 daN (1 000 lbf) pull in any direction.

5.3.7 To facilitate repair and assembly, component parts shall be readily removable with hand tools and shall be interchangeable.

5.3.8 The container's body shall not contain rough or sharp edges potentially dangerous to personnel, cargo, airplane or terminal handling equipment. Any gussets in the door opening shall be of minimum size, consistent with the strength and/or deflection requirements.

5.3.9 The minimum height dimension of the container is 1 600 mm (63 in) for standard height (contours C, E, F, N or P) containers and 1 118 mm (44 in) for low-height (contours G or H) containers.

5.4 Doors

5.4.1 Doors shall be designed to avoid finger-pinching hazards and be of sufficient strength to contain the load during air and ground transportation. It shall be possible for one person to open or close the door and any associated net or hardware in no more than 1 min for full-width units (base sizes A, L, M and Q), and no more than 15 s for half-width units (base sizes K and P).

It shall be possible to open any type of door without exceeding a height of 2,5 m (98 in), measured from the underside of the base. The door shall be capable of being opened with a 102 mm (4 in) high obstacle adjacent to the base.

The door shall be stowable on top of the unit. Means of retention in the open position shall be provided, which shall be able to maintain the door in the open and stowed position in wind and blast up to a minimum of 110 km/h (60 knots).

5.4.2 The door(s) shall have a minimum number of securing devices to sustain the handling loads at maximum gross mass without unlocking. These devices are required to positively secure the door(s) in the closed position. They should be so located that they cannot damage, or become damaged by, an adjacent container. No tools shall be required to operate the door(s) or the securing devices.

5.4.3 In general, containers have only one door situated on a long side of the unit. In some cases, for operational reasons, size K or P units may have a door on each long side.

Doors are generally rectangular, but may vary to suit the container contour, the choice of structural shape, or to provide enhanced or full-width door opening.

On contour G and H containers (see [Clause 4](#) and [Annexes K](#) and [L](#)), the door design shall provide a horizontal opening over half the depth of the roof panel in order to allow a person standing in the opening for container build-up and break-down. In the interest of ergonomic conditions improvement, it is recommended to also consider such an opening for all other contours covered by this International Standard.

5.4.4 Handles, straps or hand holds shall be provided on each door for handling the door and for manual movement of the container by one person. These devices shall be able to withstand a 445 daN (1 000 lbf) pull in any direction. They shall provide 150 mm (6 in) wide by 75 mm (3 in) deep space for gripping with a gloved hand. They shall be designed not to exceed the maximum outer contour, and so they can cause no damage to adjacent units.

5.5 Internal tie-down

Provision shall be made for internal restraint of the load, such as tie-down rings and/or tie-down track in accordance with ISO 7166 around the base edges, including at least the corners. Each fitting shall be capable of supporting a 2 225 daN (5 000 lbf) load in any direction, using an ISO 9788 double stud tie-down fitting in the case of track conforming to ISO 7166.

5.6 Placard holders

5.6.1 One or more placard holders to accept destination placards of standard size A5 [210 mm × 148 mm (8 1/4 in × 5 7/8 in)] shall be provided adjacent to the door(s). The upper edge of the holder shall not be more than 1 020 mm (40 in) from the bottom of the base.

5.6.2 It is suggested that the placard holder should have the alternative capability of being used as a board for chalk or grease pencil markings.

5.7 Design options

The following may be added as design options required by a purchaser:

- a) knock-down capability (knock-down and reassembly shall be carried out after [Clause 7](#) tests);
- b) components and sub-assemblies interchangeability;
- c) internal shelf capability (see ISO 6517, 4.4.4);
- d) fork-lifting capability (see 5.1.6 for applicable requirements);
- e) fork-lifting and stacking capability (see 5.1.7);
- f) customs and security sealing (see [Clause 9](#)).

6 Flight conditions performance and testing

6.1 Pressure equalization and rapid decompression

6.1.1 For a normal flight condition, a minimum venting area of 5 cm²/m⁻³ (0,02 in²/ft³) of container internal volume shall be provided in accordance with ISO 11242, if the door seals venting area is not sufficient.

6.1.2 For rapid decompression in the event of an aircraft emergency, the container shall, in accordance with ISO 11242, provide a minimum decompression venting area of 100 cm²/m³ (0,45 in²/ft³) of container internal volume to become open in a duration of less than 0,2 s when submitted to a maximum pressure differential from inside of 14 kPa (2,0 lb/in²) if the door seals area is not sufficient to fulfil this venting requirement

If the specific design requires a “blowout” device to achieve the required venting area, the “blowout” device shall remain attached to the container after activation.

6.1.3 These venting areas shall be adequately protected from cargo load shift to ensure that the minimum area is maintained during all normal flight conditions and during emergency operations. Refer to ISO 11242 for the pressure equalization requirements.

6.2 Flight loads

6.2.1 In order to demonstrate, as required by the aircraft Weight and Balance Manuals, that neither the container nor its contents can become a hazard or damage the aircraft structure under flight conditions, the container shall be submitted to tests under the maximum loads to be encountered in flight, per [Table 2](#).

Table 2 — Flight loads tests of non-certified containers

Container base size	Test loads N (lbf)					ISO 21100 test restraint configuration to be used	Restraint configurations notes
	Forward	Aft	Sides	Up	Down		
A	37 000 (8 300)	37 000 (8 300)	37 000 (8 300)	67 000 (15 000)	125 000 (28 000)	RC A2	—
K	15 500 (3 500)	15 500 (3 500)	15 500 (3 500)	29 000 (6 500)	53 000 (11 900)	RC K	Note 1 non-applicable (see Table 3)
L	31 000 (7 000)	31 000 (7 000)	31 000 (7 000)	58 000 (13 000)	106 000 (23 800)	RC L	Note 1 non-applicable (see Table 3)
M	40 000 (9 000)	40 000 (9 000)	40 000 (9 000)	75 000 (16 800)	133 300 (30 600)	RC A2	—
P	12 000 (2 700)	12 000 (2 700)	12 000 (2 700)	22 000 (5 000)	40 000 (9 000)	RC P	Note 1 non-applicable (see Table 3)
Q	24 000 (5 400)	24 000 (5 400)	24 000 (5 400)	44 000 (10 000)	80 000 (18 200)	RC Q	Note 1 non-applicable (see Table 3)

6.2.2 For sizes K, L, P and Q, the tests in 6.2.1 and [Table 2](#) shall be supplemented by the additional tests per [Table 3](#) in order to demonstrate the ability to withstand, without creating a hazard to the flight, the loads resulting from up to seven units stacked loading without intermediate restraints in certain aircraft types.

Table 3 — Additional load tests for sizes K, L, P and Q^a

Container base size	Nominal mass of tested container	Forward or aft test load on container base edge ^c	Restraint condition
K^b	1 585 kg (3 500 lb)	93 000 N (21 000 lbf)	2 forward or aft restraints
L	3 170 kg (7 000 lb)	186 000 N (42 000 lbf)	4 forward or aft restraints
P	1 225 kg (2 700 lb)	72 000 N (16 000 lbf)	2 forward or aft restraints
Q	2 450 kg (5 400 lb)	144 000 N (32 000 lbf)	3 forward or aft restraints

^a Test load equivalent to six additional units. Corresponds to ISO 21100:2014 RCs.

NOTE With modified restraint configuration.

^b Not applicable to DKG and DKH contours containers.

^c On base edge opposite to restraints.

6.2.3 The container shall be tested under the loads shown in [Table 2](#) with a centre of gravity (C.G.) located 864 mm (34 in) high and offset 10 % from the base's geometric centre in each horizontal direction (fore and aft, laterally).

6.2.4 The container shall be tested while exclusively restrained by its base, in the ISO 21100 restraint system's configuration shown in [Table 2](#) for the relevant base size. The load, including additional base edge load (note A of ISO 21100:2014 RC K, L, P, Q) where applicable, shall be applied for a minimum of 3 s.

6.2.5 Analysis or numeric simulation, if used instead of testing, shall use the same assumptions.

6.2.6 On completion of the tests, the tested container or parts thereof may exhibit damage or permanent deformation, but shall not deform or rupture to the extent of discharging its contents.

Analysis or numeric simulation, if used, shall confirm that the container would not deform or rupture to the extent its contents would be discharged under the test conditions.

NOTE For this purpose, typical content is defined as a rectangular cargo box with dimensions of 600 mm × 400 mm × 250 mm (24 in × 16 in × 10 in), loaded in any direction.

7 Ground conditions performance and testing

7.1 General

In order to demonstrate that the container can withstand ground operation conditions without damage detrimental to cargo or to the continuing ability to withstand the flight loads, the container shall be submitted to the tests hereafter.

7.2 Bridging and cresting

7.2.1 The container loaded to its maximum gross mass shall be capable of traversing from one item of handling equipment to another when there exists a height difference up to 150 mm (6 in) at the junction. At the point where the container balances on the end of the higher surface, the entire load shall be supported by one row of rollers per ISO 4116. Carry out the test 20 times.

7.2.2 Upon completion of the test, the container shall show neither permanent deformation nor abnormality that will render it unsuitable for use, and those dimensional requirements affecting handling and interchange shall be met. The door(s) shall open and close with no prevalent binding, and the locks shall engage and disengage with ease.

7.3 Impact test

7.3.1 The container loaded to its maximum gross mass with the minimum centre of gravity (C.G.) height of 635 mm (25 in) for low-height containers, i.e. DKH and DKG, 864 mm (34 in) for other container sizes, longitudinal eccentricity within 10 % of the base length, and lateral eccentricity within 10 % of the base width, shall be impacted at the base of the unit at a rate of 0,3 m.s⁻¹ (1 ft/s) against a vertical rigid solid bar 51 mm (2 in) high, on each side of the base of the unit to be tested.

7.3.2 The impact test shall consist of at least 50 test impacts on each side of the container base in accordance with 7.3.1. Twenty five percent of these impacts shall be initiated with the container at 15° offset to the leading edge in the direction of travel, and an additional 25 % of these would be on the other corner.

7.3.3 On completion of these tests, the container shall not discharge its contents, and any permanent set of the container contour shall not exceed 19 mm (0,75 in) at the top of the container, decreasing linearly to 3 mm (0,12 in) at the base level. The door(s) shall open and close with no prevalent binding, and the locks shall engage and disengage with ease.

7.4 Rain test

7.4.1 The container is to be designed to prevent the ingress of water such as might be experienced in heavy driving rain. It shall be demonstrated that in these conditions its contents will be undamaged by water ingress.

7.4.2 Apply a stream of water to all joints and seams of the container from a nozzle of 12,7 mm (0,5 in) inside diameter at a pressure of about 1 bar⁶⁾ [corresponding to a head of about 10 m (33 ft) of water] on the upstream side of the nozzle. Hold the nozzle at a distance of 1,5 m (5 ft) from the corner under test, and move the stream at a speed of 100 mm.s⁻¹ (4 in/s).

6) 1 bar = 100 kPa.

Procedures involving the use of several nozzles are acceptable providing that each joint or seam is subjected to a water loading no less than that which would be given by a single nozzle.

7.4.3 Upon completion of the test, the container shall be free from any penetration of water. Limited water ingress is allowable in the door area on containers with flexible doors.

7.5 Racking test

7.5.1 Secure the container to a restraint system equivalent to the applicable testing restraint configuration in ISO 21100 (see [Table 2](#)). Apply horizontally to one side of the container a test load equal to the maximum gross weight, less tare. Simultaneously apply an equal test load downwards to the top surface of the base.

Repeat the test with the test load applied to the side adjacent to the side previously tested. Should their structure not be identical, test the opposite sides in the same manner.

7.5.2 The deflection of the intersection of the top and side panel in relation to the base shall not exceed 38 mm (1,5 in) out of the maximum allowable contour, and the door(s) shall not be released.

7.5.3 Upon completion of the test, the container shall show neither detrimental permanent deformation nor abnormality which will render it unsuitable for use, and the dimensional requirements affecting handling, securing and interchange shall be satisfied.

8 Markings

8.1 All containers complying with this International Standard shall be marked with the following information:

- a) the mention "ISO 4118:2015", or designation of any other standard the container was built and tested to;
- b) the name and address of the manufacturer ;
- c) the nominal (production average) tare weight of the container to the nearest kilogram and even number of pounds in the format: "WEIGHT: kg (..... lb)";
- d) the maximum operational gross mass in kilograms and pounds in the format: "MGW: kg (..... lb)";
- e) the serial number or date of manufacture or both.

The lettering size shall be large enough to insure good readability and shall not be less than 25 mm (1 in) high for the maximum gross mass and tare weight.

8.2 The following additional markings shall also be included. The manufacturing part number and burn rate lettering sizes should be large enough to ensure good readability. The ID code marking shall be in contrasting colour, shall not be less than 100 mm (4 in) high and shall be located at the top of the outboard and inboard panels at a height of not less than 1 150 mm (45 in). For a low-height container, i.e. DKH or DKG, this minimum height may be reduced to 890 mm (35 in) on both sides of the container.

- a) ID Code
- b) Mfg. Part No.
- c) Burn rate

The burn rate shown, in mm (in) per minute, shall be the one determined for the container's primary material under 5.1.10.

NOTE The ID code is an international unit designation and marking system consisting of

- 1) three characters type and size code (see title of relevant Annex for applicable code),
- 2) four or five digits individual serial number, and
- 3) two characters owner code (airline or non-airline).

ID codes are assigned by the ULD Registrar, International Air Transport Association (IATA), 800 Place Victoria, P.O. Box 113, Montréal, Québec, Canada H4Z 1M1. For more details on the above markings, see IATA ULD Regulations Standard Specification 40/0.^[5]

8.3 In addition, the container shall be marked with a placard containing its serviceability/maximum allowable damage limits [see 10.2 (e)], preferably in the form of the IATA Operational Damage Limits Notice (ODLN) placard (see IATA ULD Regulations Standard Specification 40/3).^[7]

9 Customs/security sealing (optional)

The container shall be designed, constructed and equipped in such a manner that

- a) no goods can be removed from, or introduced into, the sealed container without leaving obvious traces of tampering or breaking the customs or security seal,
- b) customs and security seals can be simply and effectively affixed,
- c) the container contains no concealed space where goods may be hidden, and
- d) all spaces capable of holding goods are readily accessible for customs or security inspection.

10 Manufacturer's instructions

10.1 The manufacturer shall deliver to the purchaser together with the first batch of containers a set of written instructions including at least

- a) a certificate of compliance with the requirements of the present International Standard,
- b) appropriate instructions to the operators (see 10.2), and
- c) recycling instructions (see 5.1.11).

Document (a) shall be renewed at each subsequent delivery. No Authority approval is required.

10.2 Instructions to the operators under 10.1 (b) should include at least

- a) intended conditions of use, and any exclusions there from, if applicable,
- b) environmental assessment, health and safety precautions, known chemical incompatibilities,
- c) appropriate aircraft installation instructions,
- d) operational use recommendations referring to recognized applicable industry standards
- e) recommended serviceability limits in order to maintain the container's continuing ability to withstand the flight loads, and
- f) inspection and repair instructions with parts and materials procurement information [Component Maintenance Manual (CMM) or equivalent and Illustrated Parts List].

11 Quality control

11.1 Design and production

11.1.1 Though not subject to airworthiness authority oversight, design, testing and production of containers complying with this International Standard should be performed within the framework of an appropriate manufacturing quality control program.

11.1.2 Quality control programs meeting the requirements appropriate for aircraft containers of, for example, ISO 9001, or an equivalent pertinent industry standard, are recommended.

11.2 Operations

11.2.1 The air carrier the Air Operator Certificate (AOC) of whom covers the aircraft concerned is responsible for ensuring compliance with the requirements applicable to non-certified containers condition, loading and installation on board the aircraft. These requirements are contained in the aircraft type or subtype Weight and Balance Manual, and may include specific requirements, e.g. maximum weight of packages, minimum filling, etc., that shall be complied with. They always include maximum allowable centre of gravity (C.G.) limits, generally in line with those of ISO 21100 for corresponding size certified containers. In addition, the manufacturer's serviceability limits [see 10.2 (e)] shall be complied with.

11.2.2 Containers operations, installation on aircraft and in-service inspection processes shall be monitored and their quality and effectiveness be regularly assessed by an independent organization in the framework of the air carrier's internal evaluation and quality control program (see CCAR-121, 14 CFR Part 121 and AC 120-59, EU-OPS 1.035 and its AMC and IEM).

11.2.3 Accordingly, each container build-up site, including when it is located at a subcontractor's premises, should be subject to inspection, investigation or audit from the air carrier's quality control department.

11.2.4 It is also recommended that airports handling agencies facilities performing installation of containers on board air carriers aircraft maintain their own continuous quality control program meeting the requirements of ISO 9001, or an equivalent pertinent industry standard.

11.2.5 In addition, it is recommended that any significant incident, in flight or on the ground at aircraft loading or offloading, resulting from or related to improper performance, installation or inspection of (a) non-certified containers(s) be reported and subject to carrier's quality control department investigation, in order to be analysed and corrective action to be taken to avoid its reoccurrence.

11.2.6 Any occurrence of damage to an aircraft due to an improperly designed, maintained or operated non-certified container shall be reported to the air carrier's quality control department to be investigated as a flight safety occurrence. The container involved shall be kept aside for the investigation and shall not be returned to service prior to being inspected by qualified personnel and found in a safe condition.

Dimensions in millimetres

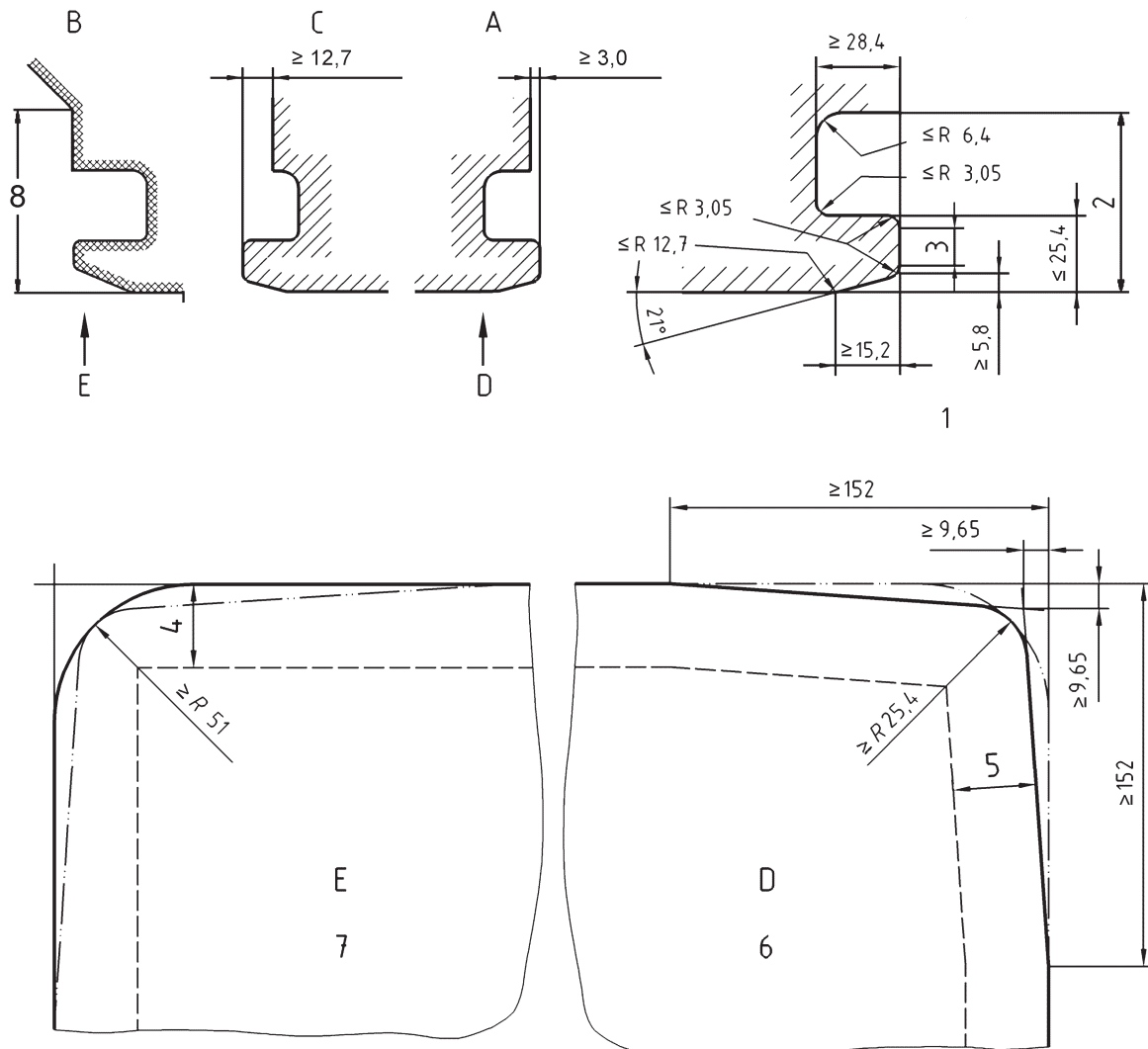

Key

- A inboard edge (detail)
- B outboard edge (detail)
- C forward and aft edges (detail)
- 1 base details typical for all edges
- 2 63,5 min. (see [Table 4](#))
- 3 10,2 min. flat
- 4 28,4 min. recess parallel to outer edge of base except at corner radius
- 5 28,4 min. recess parallel to outer edge of base shall be kept clear around complete periphery of base
- 6 showing tapered corner with radiused corner option shown chain dotted
- 7 showing radiused corner with tapered corner option shown chain dotted
- 8 89 min. (see [Table 4](#))

Figure 1 — Sizes K, P, Q container base dimensional requirements

Dimensions in millimetres

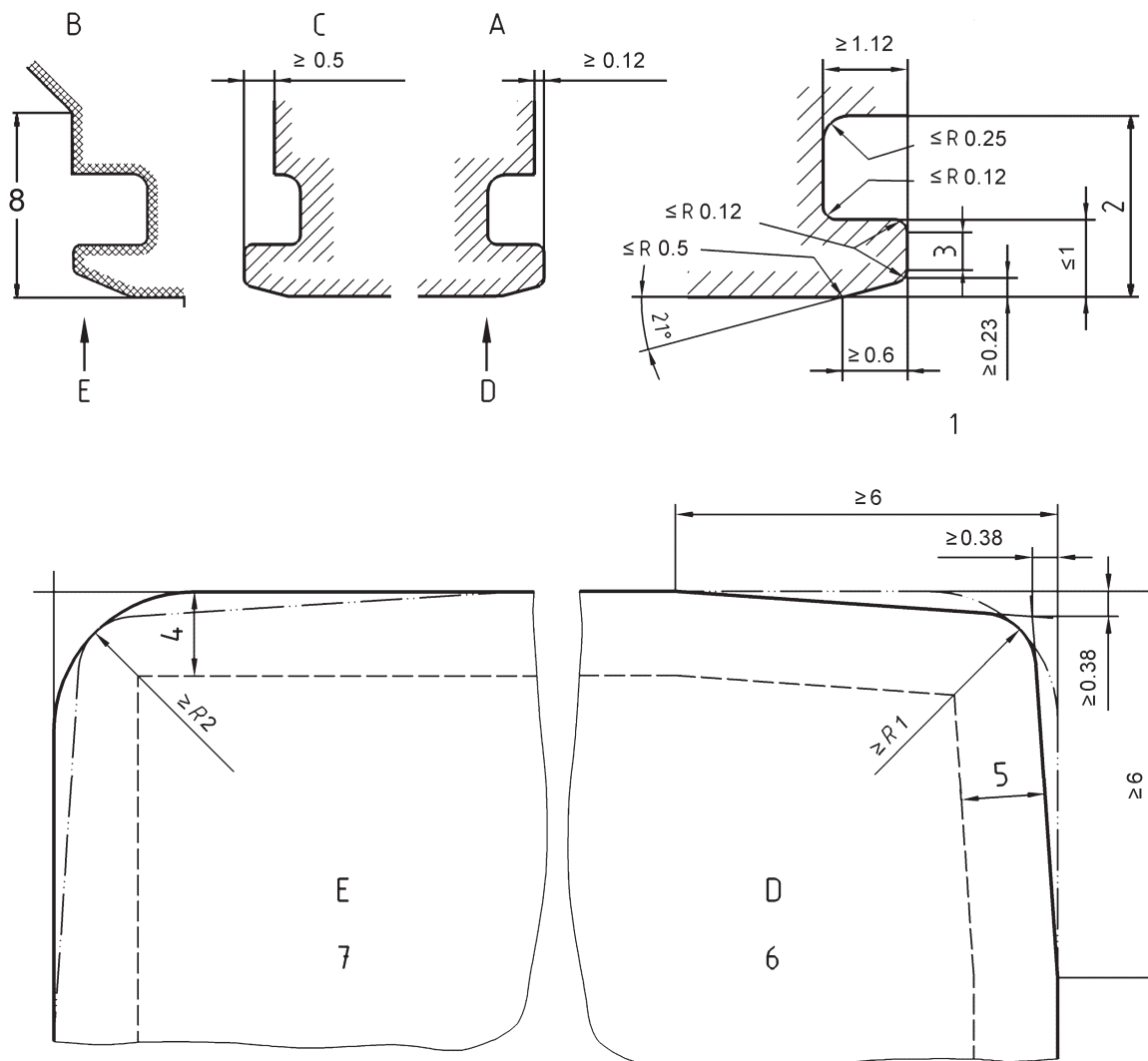

Key

- A inboard edge (detail)
- B outboard edge (detail)
- C forward and aft edges (detail)
- 1 base details typical for all edges
- 2 2,5 min. (see Table 4)
- 3 0,4 min. flat
- 4 1,12 min. recess parallel to outer edge of base except at corner radius
- 5 1,12 min. recess parallel to outer edge of base shall be kept clear around complete periphery of base
- 6 radiused corner only
- 7 radiused corner only
- 8 4,25 min. (see Table 4)

Figure 2 — Sizes A, L, M container base dimensional requirements

Table 4 — Base size and edges recess height

Dimensions in millimetres (inches)

Code	Base size	Minimum recess height	Minimum height under slope	Width	Contoured unit ID code	Rectangular unit ID code
K	1 534 × 1 562 (60,4 × 61,5)	63,5 (2,5) min.	89 (3,5) min.	Half width Full width	DKC, DKE, DKN, DKG DKH	DKP
L	1 534 × 3 175 (60,4 × 125)	63,5 (2,5) min.	108 (4,25) min.	Full width	DLF	DLP
P	1 534 × 1 194 (60,4 × 47,0)	63,5 (2,5) min.	89 (3,5) min.	Half width	DPE, DPN	
Q	1 534 × 2 438 (60,4 × 96,0)	63,5 (2,5) min.	89 (3,5) min.	Full width	DQF	DQP
A	2 235 × 3 175 (88,0 × 125)	63,5 (2,5) min.	108 (4,25) min.	Full width	DAF	DAP
M	2 438 × 3 175 (96,0 × 125)	63,5 (2,5) min.	108 (4,25) min.	Full width	DMF	DMP

Annex A (normative)

Code DKC half-width contoured containers dimensions and design requirements

A.1 Dimensions

Dimensions are given in [Figure A.1](#), in millimetres (inches).

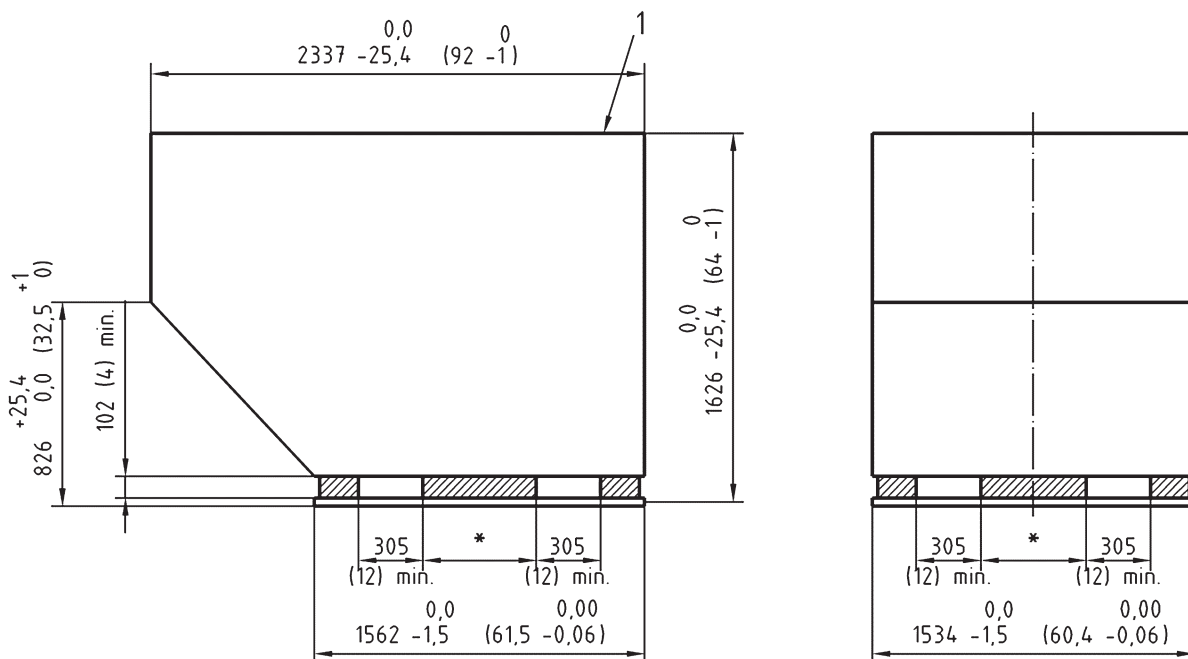

Key

1 Contour C

Figure A.1 — Dimensions of code DKC half-width contoured containers

Aircraft restraint space requirements are shown in [Figure 1](#). Contour dimensions and tolerances are theoretical: actual horizontal contour dimensions and base periphery recess all around shall meet [Figure 1](#) requirements.

A.1.1 Any dimensions denoted by * should be identical.

A.1.2 The centre line of the optional forklift entries should be located toward the outboard side by 156 mm (6,15 in) to accommodate the geometrical C.G. deviation.

A.2 Forklift entries (optional)

If required, forklift entries shall be provided on at least the two long sides, although three-way entry is preferred if possible. At least chamfers are recommended. See 4.2.5, 4.2.6 and 4.2.7.

A.3 Doors

A.3.1 It is suggested that the door(s) be provided on (a) long side(s) for maximum loadability.

A.3.2 The door(s) should have locking devices and customs and security sealing capability.

Annex B (normative)

Code DKE/DKN half-width contoured containers dimensions and design requirements

B.1 Dimensions

Dimensions are given in [Figure B.1](#), in millimetres (inches).

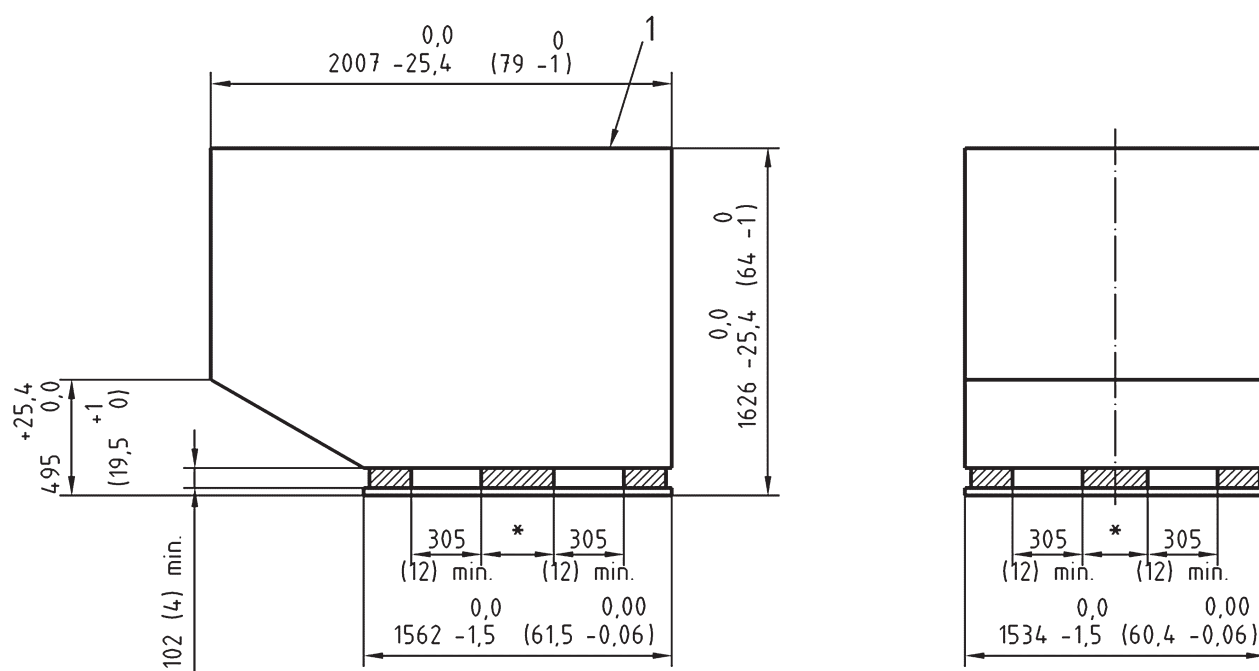

Key

1 Contour E (N)

Figure B.1 — Dimensions of code DKE or DKN half-width contoured containers

Aircraft restraint space requirements are shown in [Figure 1](#). Contour dimensions and tolerances are theoretical: actual horizontal contour dimensions and base periphery recess all around shall meet [Figure 1](#) requirements.

B.1.1 Any dimensions denoted by * should be identical.

B.1.2 The centre line of the optional forklift entries should be located toward the outboard side by 102 mm (4 in) to accommodate the geometrical C.G. deviation.

B.1.3 The DKE code applies to containers without forklift tineways and DKN to container with forklift tineways.

B.1.4 Forklift entries (optional)

If required, forklift entries shall be provided on at least the two long sides, although three-way entry is preferred if possible. At least chamfers are recommended. See 4.2.5, 4.2.6 and 4.2.7.

B.2 Doors

B.2.1 It is suggested that the door(s) be provided on (a) long side(s) for maximum loadability.

B.2.2 The door(s) should have locking devices and customs and security sealing capability.

Annex C (normative)

Code DKP half-width rectangular containers dimensions and design requirements

C.1 Dimensions

Dimensions are given in [Figure C.1](#), in millimetres (inches).

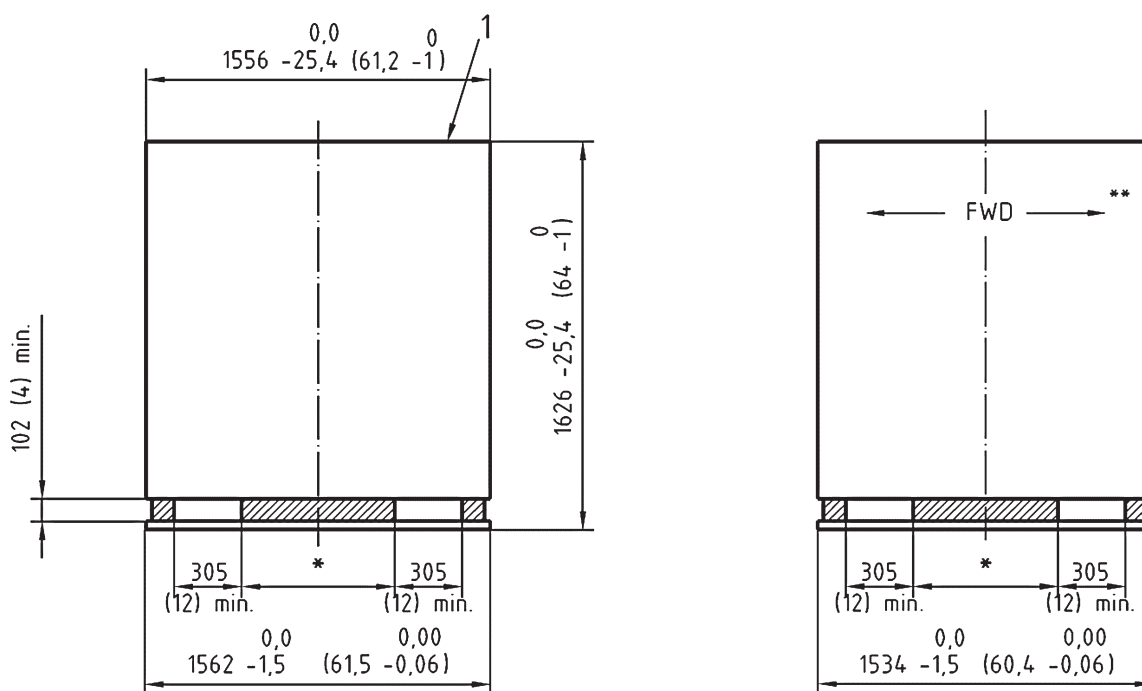

Key

1 Contour P

Figure C.1 — Dimensions of code DKP half-width rectangular containers

Aircraft restraint space requirements are shown in [Figure 1](#). Contour dimensions and tolerances are theoretical: actual horizontal contour dimensions and base periphery recess all around shall meet [Figure 1](#) requirements.

C.1.1 Any dimensions denoted by * should be identical.

C.1.2 **: Mark in accordance with [C.4](#).

C.2 Forklift entries (optional)

If required, forklift entries shall be provided on at least the two long sides, although four-way entry is preferred if possible. At least chamfers are recommended. See 4.2.5, 4.2.6 and 4.2.7.

C.3 Doors

C.3.1 It is suggested that the door(s) be provided on (a) long side(s) for maximum loadability.

C.3.2 The door(s) should have locking devices and customs and security sealing capability.

C.4 Markings

Both inboard and outboard panels shall be marked to clearly indicate the sides of the container that shall face forward or aft in the aircraft, as shown in [Figure C.1](#).

Annex D (normative)

Code DLF full-width contoured containers dimensions and design requirements

D.1 Dimensions

Dimensions are given in [Figure D.1](#), in millimetres (inches).

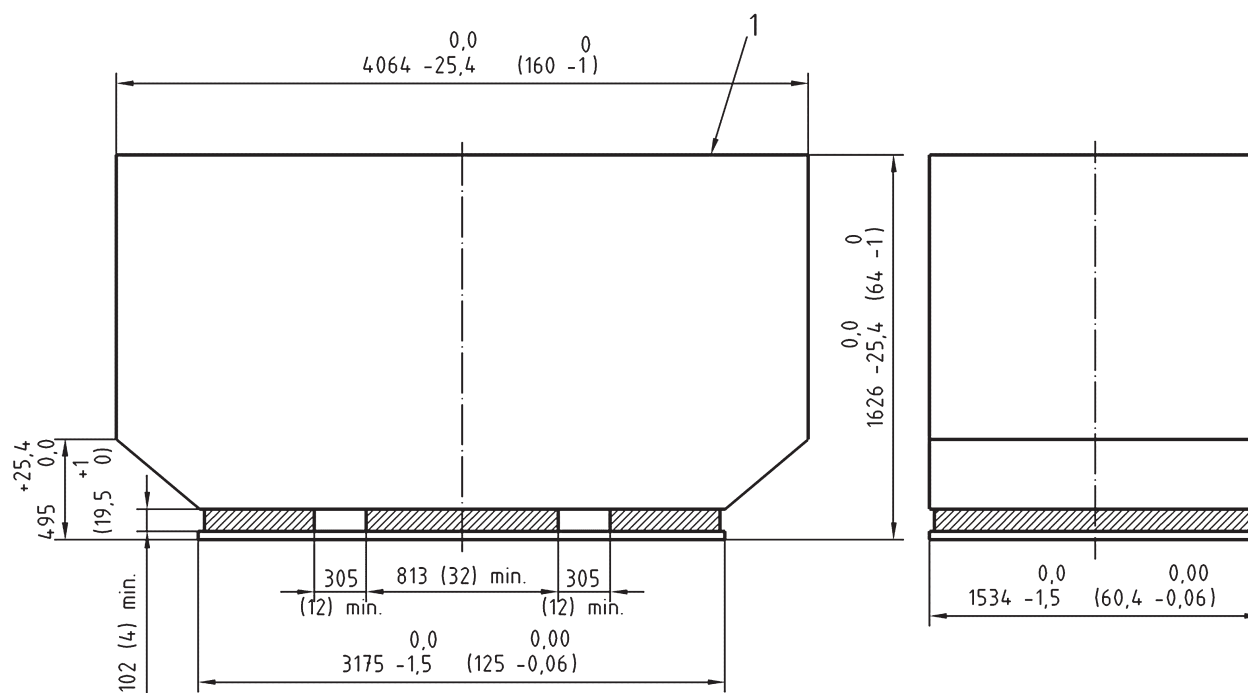

Key

1 Contour F

Figure D.1 — Dimensions of code DLF full-width contoured containers

Aircraft restraint space requirements are shown in [Figure 2](#). Contour dimensions and tolerances are theoretical: actual horizontal contour dimensions and base periphery recess all around shall meet [Figure 2](#) requirements.

D.2 Forklift entries (optional)

If required, forklift entries shall be provided on the two long sides. At least chamfers are recommended. See 4.2.5, 4.2.6 and 4.2.7.

D.3 Doors

D.3.1 It is suggested that the door(s) be provided on (a) long side(s) for maximum loadability.

D.3.2 The door(s) should have locking devices and customs and security sealing capability.

Annex E (normative)

Code DLP full-width rectangular containers dimensions and design requirements

E.1 Dimensions

Dimensions are given in [Figure E.1](#), in millimetres (inches).

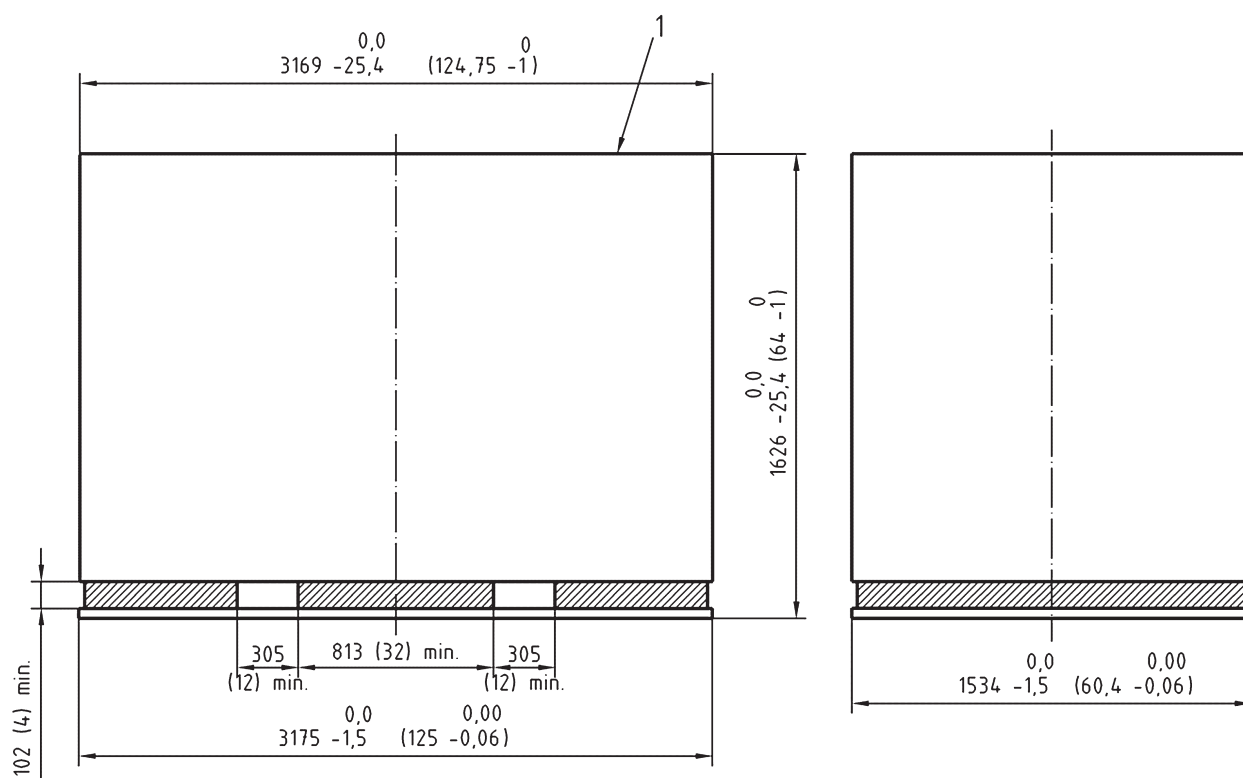

Key

1 Contour P

Figure E.1 — Dimensions of code DLP full-width rectangular containers

Aircraft restraint space requirements are shown in [Figure 2](#). Contour dimensions and tolerances are theoretical: actual horizontal contour dimensions and base periphery recess all around shall meet [Figure 2](#) requirements.

E.2 Forklift entries (optional)

If required, forklift entries shall be provided on the two long sides. At least chamfers are recommended. See 4.2.5, 4.2.6 and 4.2.7.

E.3 Doors

E.3.1 It is suggested that the door(s) be provided on (a) long side(s) for maximum loadability.

E.3.2 The door(s) should have locking devices and customs and security sealing capability.

Annex F (normative)

Code DPE/DPN half-width contoured containers dimensions and design requirements

F.1 Dimensions

Dimensions are given in [Figure F.1](#), in millimetres (inches).

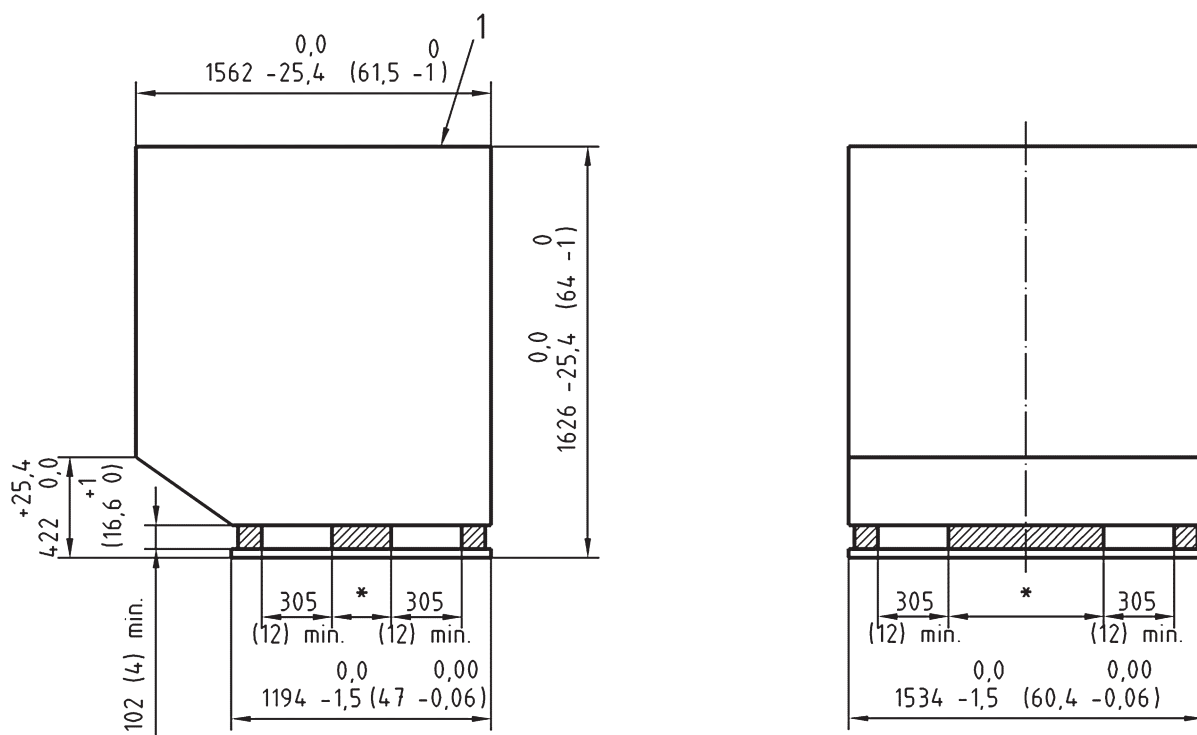

Key

1 Contour E (N)

Figure F.1 — Dimensions of code DPE or DPN half-width contoured containers

Aircraft restraint space requirements are shown in [Figure 1](#). Contour dimensions and tolerances are theoretical: actual horizontal contour dimensions and base periphery recess all around shall meet [Figure 1](#) requirements.

F.1.1 Any dimensions denoted by * should be identical.

F.1.2 The DPE code applies to containers without forklift tineways, and DPN to container with forklift tineways.

F.2 Forklift entries (optional)

If required, forklift entries shall be provided on at least the two long sides, although three-way entry is preferred if possible. At least chamfers are recommended. See 4.2.5, 4.2.6 and 4.2.7.

F.3 Doors

F.3.1 It is suggested that the door(s) be provided on (a) long side(s) for maximum loadability.

F.3.2 The door(s) should have locking devices and customs and security sealing capability.

Annex G (normative)

Code DQF full-width contoured containers dimensions and design requirements

G.1 Dimensions

Dimensions are given in [Figure G.1](#), in millimetres (inches).

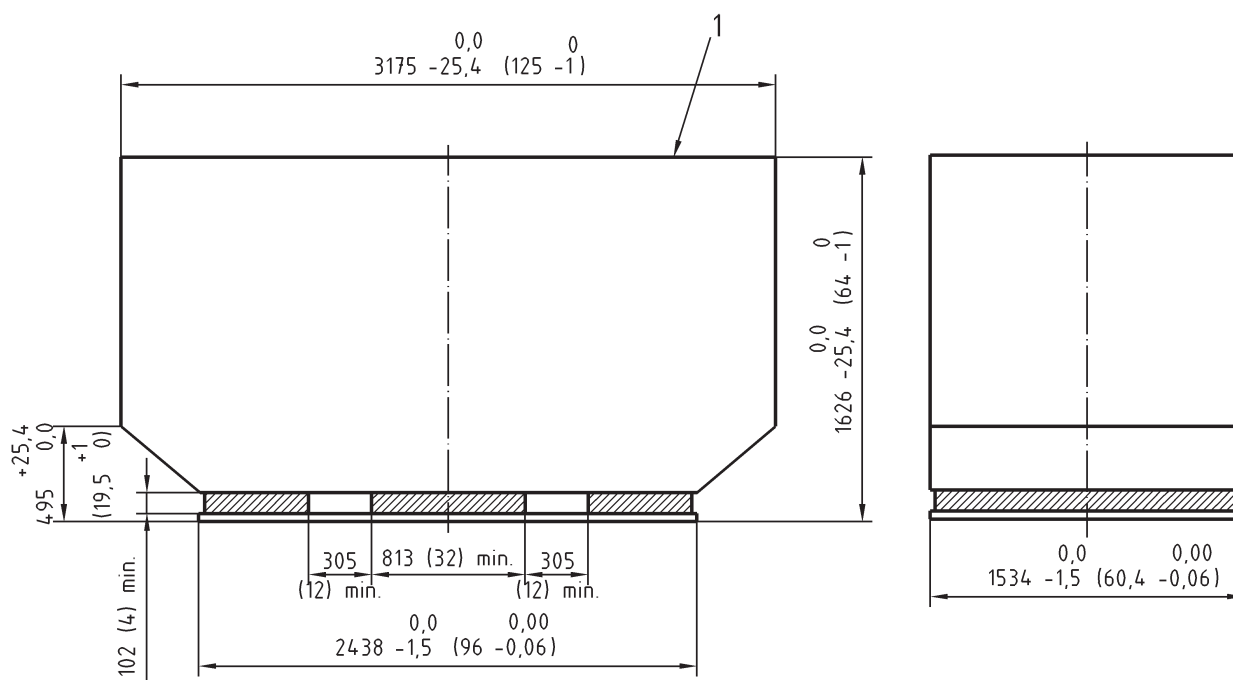

Key

1 Contour F

Figure G.1 — Dimensions of code DQF full-width contoured containers

Aircraft restraint space requirements are shown in [Figure 1](#). Contour dimensions and tolerances are theoretical: actual horizontal contour dimensions and base periphery recess all around shall meet [Figure 1](#) requirements.

G.2 Forklift entries (optional)

If required, forklift entries shall be provided on the two long sides. At least chamfers are recommended. See 4.2.5, 4.2.6 and 4.2.7.

G.3 Doors

G.3.1 It is suggested that the door(s) be provided on (a) long side(s) for maximum loadability.

G.3.2 The door(s) should have locking devices and customs and security sealing capability.

Annex H (normative)

Code DQP full-width rectangular containers dimensions and design requirements

H.1 Dimensions

Dimensions are given in [Figure H.1](#), in millimetres (inches).

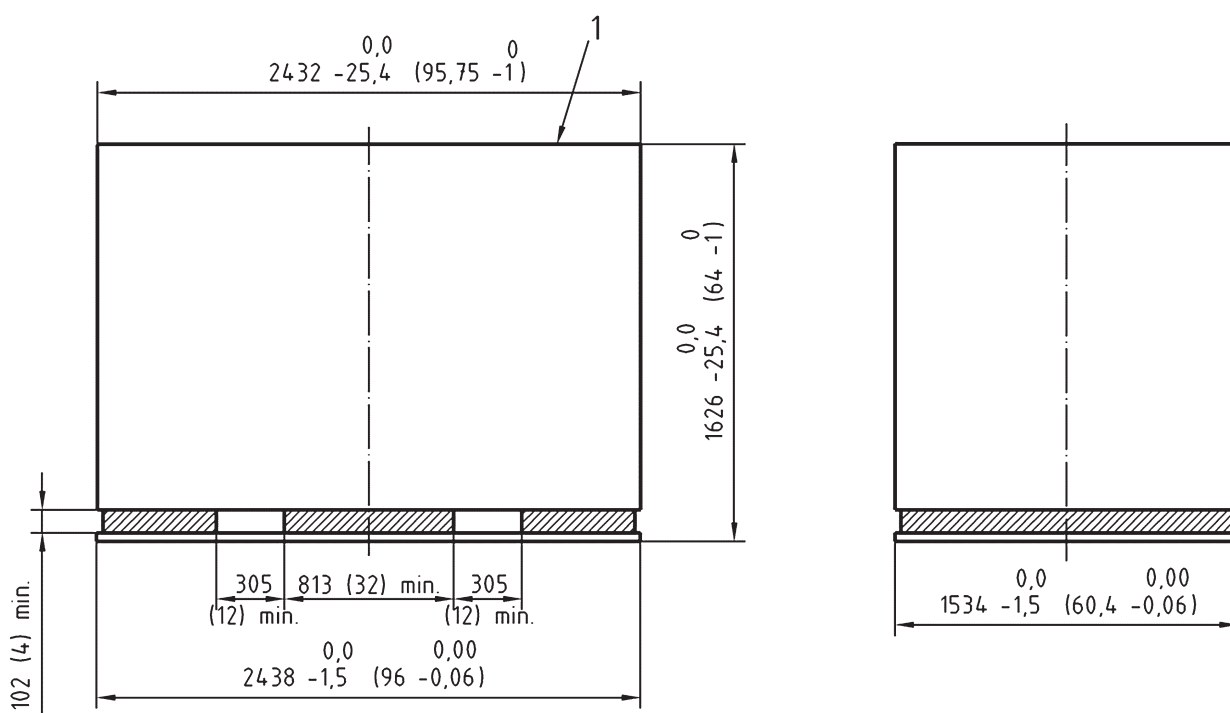

Key

1 Contour P

Figure H.1 — Dimensions of code DQP full-width rectangular containers

Aircraft restraint space requirements are shown in [Figure 1](#). Contour dimensions and tolerances are theoretical: actual horizontal contour dimensions and base periphery recess all around shall meet [Figure 1](#) requirements.

H.2 Forklift entries (optional)

If required, forklift entries shall be provided on the two long sides. At least chamfers are recommended. See 4.2.5, 4.2.6 and 4.2.7.

H.3 Doors

H.3.1 It is suggested that the door(s) be provided on (a) long side(s) for maximum loadability.

H.3.2 The door(s) should have locking devices and customs and security sealing capability.

Annex I (normative)

Code DAF full-width contoured containers dimensions and design requirements

I.1 Dimensions

Dimensions are given in [Figure I.1](#), in millimetres (inches).

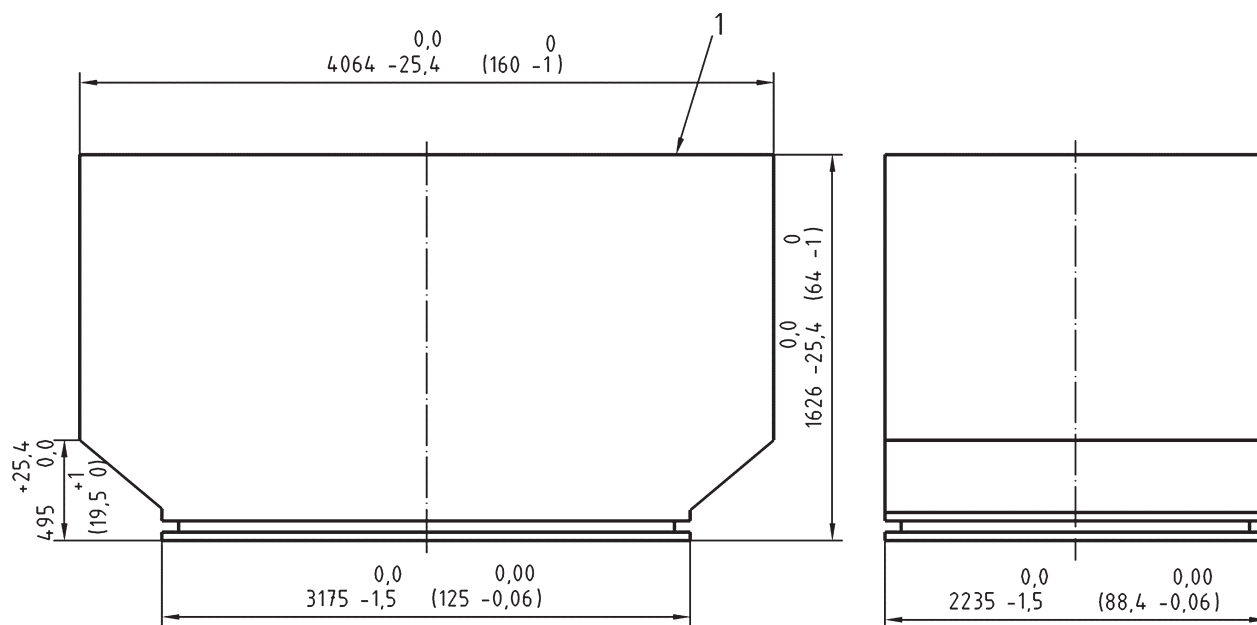

Key

1 Contour F

Figure I.1 — Dimensions of code DAF full-width contoured containers

Aircraft restraint space requirements are shown in [Figure 2](#). Contour dimensions and tolerances are theoretical: actual horizontal contour dimensions and base periphery recess all around shall meet [Figure 2](#) requirements.

I.2 Doors

I.2.1 It is suggested that the door(s) be provided on (a) long side(s) for maximum loadability.

I.2.2 The door(s) should have locking devices and customs and security sealing capability.

Annex J (normative)

Code DMF full-width contoured containers dimensions and design requirements

J.1 Dimensions

Dimensions are given in [Figure J.1](#), in millimetres (inches).

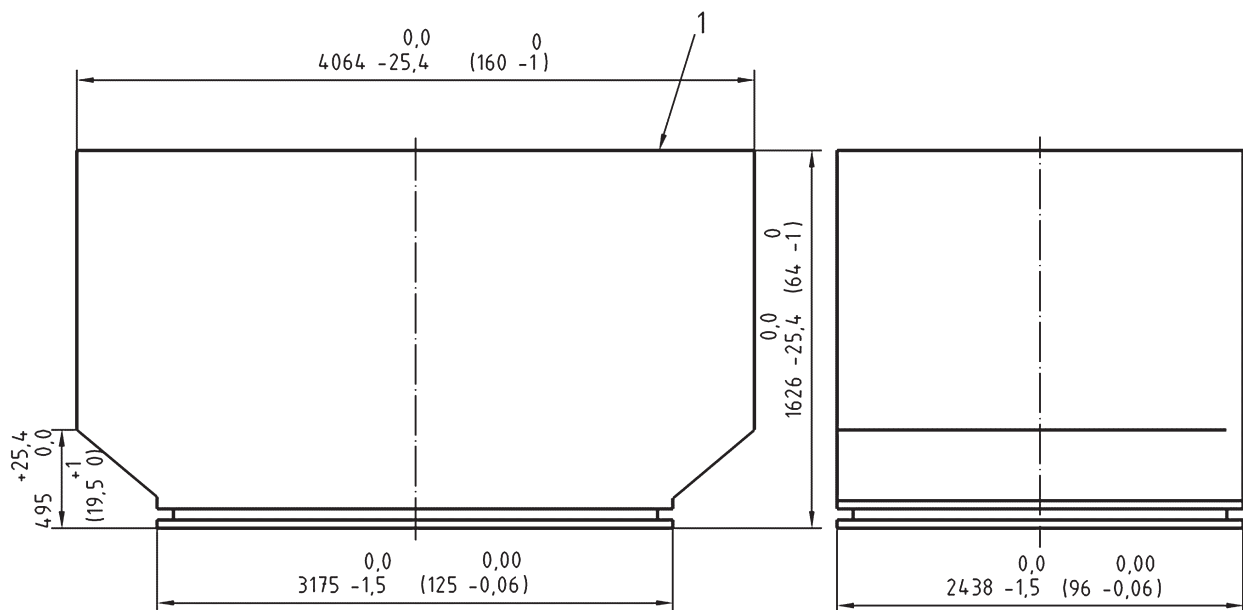

Key

1 Contour F

Figure J.1 — Dimensions of code DMF full-width contoured containers

Aircraft restraint space requirements are shown in [Figure 2](#). Contour dimensions and tolerances are theoretical: actual horizontal contour dimensions and base periphery recess all around shall meet [Figure 2](#) requirements.

J.2 Doors

J.2.1 It is suggested that the door(s) be provided on (a) long side(s) for maximum loadability.

J.2.2 The door(s) should have locking devices and customs and security sealing capability.

Annex K (normative)

Code DKH low height full-width containers dimensions and design requirements

K.1 Dimensions

Dimensions are given in [Figure K.1](#), in millimetres (inches).

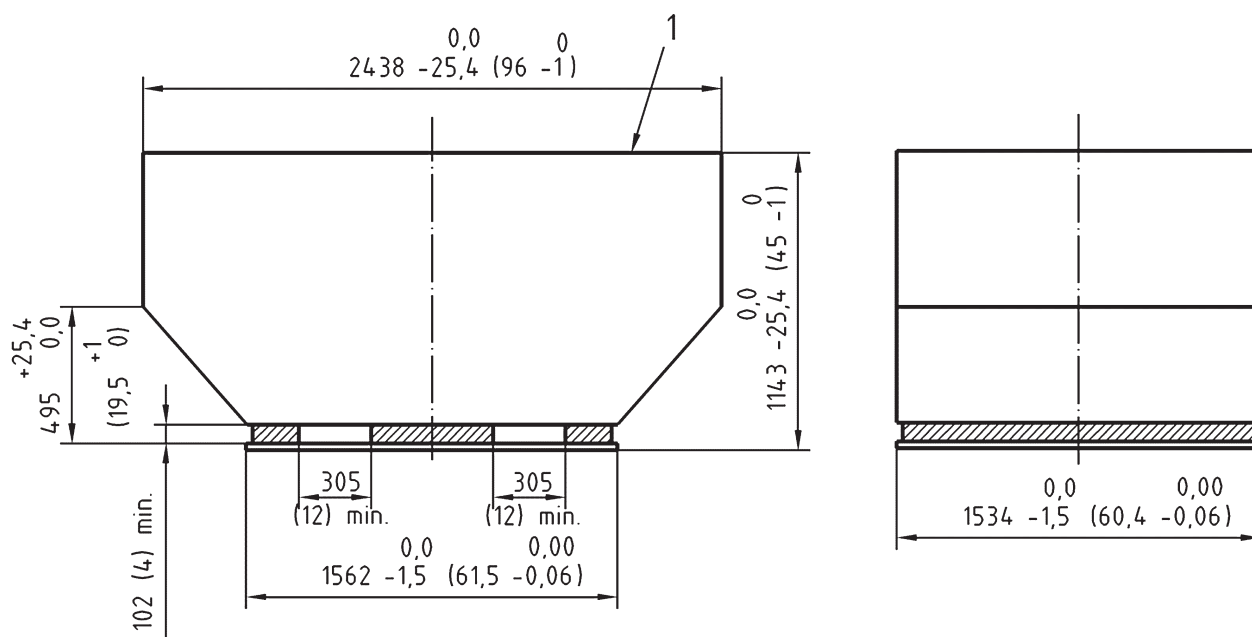

Key

1 Contour H

Figure K.1 — Dimensions of code DKH low height full-width contoured containers

Aircraft restraint space requirements are shown in [Figure 1](#). Contour dimensions and tolerances are theoretical: actual horizontal contour dimensions and base periphery recess all around shall meet [Figure 1](#) requirements.

K.2 Forklift entries (optional)

If required, forklift entries shall be provided on the two long sides. At least chamfers are recommended. See 4.2.5, 4.2.6 and 4.2.7.

K.3 Doors

K.3.1 It is suggested that the door(s) be provided on (a) long side(s) for maximum loadability.

K.3.2 The door(s) should have locking devices and customs and security sealing capability.

Annex L (normative)

Code DKG low height half-width containers dimensions and design requirements

L.1 Dimensions

Dimensions are given in [Figure L.1](#), in millimetres (inches).

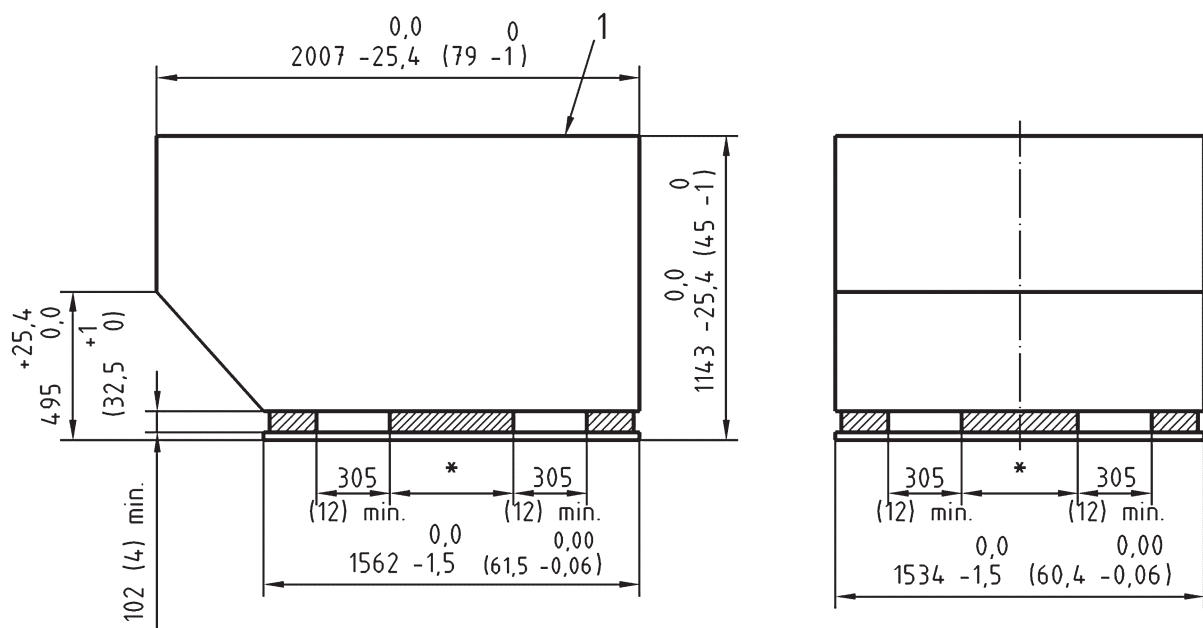

Key

1 Contour G

Figure L.1 — Dimensions of code DKG low height half-width contoured containers

Aircraft restraint space requirements are shown in [Figure 1](#). Contour dimensions and tolerances are theoretical: actual horizontal contour dimensions and base periphery recess all around shall meet [Figure 1](#) requirements.

L.1.1 Any dimensions denoted by * should be identical.

L.1.2 The centre line of the optional forklift entries should be located toward the outboard side by 102 mm (4 in) to accommodate the geometrical C.G. deviation.

L.2 Forklift entries (optional)

If required, forklift entries shall be provided on at least the two long sides, although three-way entry is preferred if possible. At least chamfers are recommended. See 4.2.5, 4.2.6 and 4.2.7.

L.3 Doors

L.3.1 It is suggested that the door(s) be provided on (a) long side(s) for maximum loadability.

L.3.2 The door(s) should have locking devices and customs and security sealing capability.

Bibliography

- [1] ISO 9001:2008, *Quality management systems — Requirements*
- [2] ISO 6517, *Air cargo — Certified lower deck containers — Design and testing*
- [3] SAE/ARP 1334,⁷⁾ *Ground equipment requirements for compatibility with aircraft unit load devices*
- [4] SAE AS 1677,⁷⁾⁸⁾ *General requirements for noncertified cargo/baggage containers*
- [5] IATA ULD Regulations Standard Specification 40/0,⁹⁾ *Marking of unit load devices*
- [6] IATA ULD Regulations Standard Specification 40/1,⁹⁾ *IATA identification code for unit load devices*
- [7] IATA ULD Regulations Standard Specification 40/3,⁹⁾ *Operational Damage Limits Notice (ODLN) for non-certified containers*
- [8] IATA ULD Regulations Standard Specification 50/0,⁹⁾ *ULD general technical requirements*
- [9] IATA ULD Regulations Standard Specification 50/7,⁸⁾ ⁹⁾ *Non-certified aircraft containers*
- [10] IATA ULD Regulations Standard Specification 80/2,⁹⁾ *Pressure equalization requirements for aircraft and shipping containers*

7) The SAE documents can be obtained from: Society of Automotive Engineers, 400 Commonwealth Drive, Warrendale PA 15096-0001, U.S.A.; or its web site www/sae.org.

8) Corresponding to this International Standard.

9) IATA publications can be obtained from: International Air Transport Association, Publications Assistant, 800 Place Victoria, P.O. Box 113, Montréal, Québec, Canada H4Z 1M1, or its web site www.iata.org.

British Standards Institution (BSI)

BSI is the national body responsible for preparing British Standards and other standards-related publications, information and services.

BSI is incorporated by Royal Charter. British Standards and other standardization products are published by BSI Standards Limited.

About us

We bring together business, industry, government, consumers, innovators and others to shape their combined experience and expertise into standards-based solutions.

The knowledge embodied in our standards has been carefully assembled in a dependable format and refined through our open consultation process. Organizations of all sizes and across all sectors choose standards to help them achieve their goals.

Information on standards

We can provide you with the knowledge that your organization needs to succeed. Find out more about British Standards by visiting our website at bsigroup.com/standards or contacting our Customer Services team or Knowledge Centre.

Buying standards

You can buy and download PDF versions of BSI publications, including British and adopted European and international standards, through our website at bsigroup.com/shop, where hard copies can also be purchased.

If you need international and foreign standards from other Standards Development Organizations, hard copies can be ordered from our Customer Services team.

Copyright in BSI publications

All the content in BSI publications, including British Standards, is the property of and copyrighted by BSI or some person or entity that owns copyright in the information used (such as the international standardization bodies) and has formally licensed such information to BSI for commercial publication and use.

Save for the provisions below, you may not transfer, share or disseminate any portion of the standard to any other person. You may not adapt, distribute, commercially exploit, or publicly display the standard or any portion thereof in any manner whatsoever without BSI's prior written consent.

Storing and using standards

Standards purchased in soft copy format:

- A British Standard purchased in soft copy format is licensed to a sole named user for personal or internal company use only.
- The standard may be stored on more than 1 device provided that it is accessible by the sole named user only and that only 1 copy is accessed at any one time.
- A single paper copy may be printed for personal or internal company use only.

Standards purchased in hard copy format:

- A British Standard purchased in hard copy format is for personal or internal company use only.
- It may not be further reproduced – in any format – to create an additional copy. This includes scanning of the document.

If you need more than 1 copy of the document, or if you wish to share the document on an internal network, you can save money by choosing a subscription product (see 'Subscriptions').

Reproducing extracts

For permission to reproduce content from BSI publications contact the BSI Copyright & Licensing team.

Subscriptions

Our range of subscription services are designed to make using standards easier for you. For further information on our subscription products go to bsigroup.com/subscriptions.

With **British Standards Online (BSOL)** you'll have instant access to over 55,000 British and adopted European and international standards from your desktop. It's available 24/7 and is refreshed daily so you'll always be up to date.

You can keep in touch with standards developments and receive substantial discounts on the purchase price of standards, both in single copy and subscription format, by becoming a **BSI Subscribing Member**.

PLUS is an updating service exclusive to BSI Subscribing Members. You will automatically receive the latest hard copy of your standards when they're revised or replaced.

To find out more about becoming a BSI Subscribing Member and the benefits of membership, please visit bsigroup.com/shop.

With a **Multi-User Network Licence (MUNL)** you are able to host standards publications on your intranet. Licences can cover as few or as many users as you wish. With updates supplied as soon as they're available, you can be sure your documentation is current. For further information, email subscriptions@bsigroup.com.

Revisions

Our British Standards and other publications are updated by amendment or revision.

We continually improve the quality of our products and services to benefit your business. If you find an inaccuracy or ambiguity within a British Standard or other BSI publication please inform the Knowledge Centre.

Useful Contacts

Customer Services

Tel: +44 345 086 9001

Email (orders): orders@bsigroup.com

Email (enquiries): cservices@bsigroup.com

Subscriptions

Tel: +44 345 086 9001

Email: subscriptions@bsigroup.com

Knowledge Centre

Tel: +44 20 8996 7004

Email: knowledgecentre@bsigroup.com

Copyright & Licensing

Tel: +44 20 8996 7070

Email: copyright@bsigroup.com

BSI Group Headquarters

389 Chiswick High Road London W4 4AL UK