

# Tractors and machinery for agriculture — Seat belts

## Part 3: Requirements for assemblies

ICS 65.060.10

## National foreword

This British Standard is the UK implementation of ISO 3776-3:2009.

The UK participation in its preparation was entrusted to Technical Committee AGE/6, Agricultural tractors and forestry machinery.

A list of organizations represented on this committee can be obtained on request to its secretary.

This publication does not purport to include all the necessary provisions of a contract. Users are responsible for its correct application.

**Compliance with a British Standard cannot confer immunity from legal obligations.**

This British Standard was published under the authority of the Standards Policy and Strategy Committee on 30 June 2009.

© BSI 2009

ISBN 978 0 580 59019 1

### Amendments/corrigenda issued since publication

Date	Comments

# INTERNATIONAL STANDARD

**ISO**  
**3776-3**

First edition  
2009-06-15

---

---

## **Tractors and machinery for agriculture — Seat belts —**

### **Part 3: Requirements for assemblies**

*Tracteurs et matériels agricoles — Ceintures de sécurité —*

*Partie 3: Exigences relatives aux assemblages*



Reference number  
ISO 3776-3:2009(E)

**PDF disclaimer**

This PDF file may contain embedded typefaces. In accordance with Adobe's licensing policy, this file may be printed or viewed but shall not be edited unless the typefaces which are embedded are licensed to and installed on the computer performing the editing. In downloading this file, parties accept therein the responsibility of not infringing Adobe's licensing policy. The ISO Central Secretariat accepts no liability in this area.

Adobe is a trademark of Adobe Systems Incorporated.

Details of the software products used to create this PDF file can be found in the General Info relative to the file; the PDF-creation parameters were optimized for printing. Every care has been taken to ensure that the file is suitable for use by ISO member bodies. In the unlikely event that a problem relating to it is found, please inform the Central Secretariat at the address given below.



**COPYRIGHT PROTECTED DOCUMENT**

© ISO 2009

All rights reserved. Unless otherwise specified, no part of this publication may be reproduced or utilized in any form or by any means, electronic or mechanical, including photocopying and microfilm, without permission in writing from either ISO at the address below or ISO's member body in the country of the requester.

ISO copyright office  
Case postale 56 • CH-1211 Geneva 20  
Tel. + 41 22 749 01 11  
Fax + 41 22 749 09 47  
E-mail [copyright@iso.org](mailto:copyright@iso.org)  
Web [www.iso.org](http://www.iso.org)

Published in Switzerland

## Contents

Page

Foreword.....	iv
<b>1</b> <b>Scope</b> .....	<b>1</b>
<b>2</b> <b>Normative references</b> .....	<b>1</b>
<b>3</b> <b>Terms and definitions</b> .....	<b>1</b>
<b>4</b> <b>Requirements</b> .....	<b>2</b>
<b>4.1</b> <b>General</b> .....	<b>2</b>
<b>4.2</b> <b>Strap material requirements</b> .....	<b>6</b>
<b>4.3</b> <b>Hardware requirements</b> .....	<b>8</b>
<b>4.4</b> <b>Additional requirements for buckles</b> .....	<b>9</b>
<b>Bibliography</b> .....	<b>13</b>

## Foreword

ISO (the International Organization for Standardization) is a worldwide federation of national standards bodies (ISO member bodies). The work of preparing International Standards is normally carried out through ISO technical committees. Each member body interested in a subject for which a technical committee has been established has the right to be represented on that committee. International organizations, governmental and non-governmental, in liaison with ISO, also take part in the work. ISO collaborates closely with the International Electrotechnical Commission (IEC) on all matters of electrotechnical standardization.

International Standards are drafted in accordance with the rules given in the ISO/IEC Directives, Part 2.

The main task of technical committees is to prepare International Standards. Draft International Standards adopted by the technical committees are circulated to the member bodies for voting. Publication as an International Standard requires approval by at least 75 % of the member bodies casting a vote.

Attention is drawn to the possibility that some of the elements of this document may be the subject of patent rights. ISO shall not be held responsible for identifying any or all such patent rights.

ISO 3776-3 was prepared by Technical Committee ISO/TC 23, *Tractors and machinery for agriculture and forestry*, Subcommittee SC 2, *Common tests*.

ISO 3776 consists of the following parts, under the general title *Tractors and machinery for agriculture — Seat belts*:

- *Part 1: Anchorage location requirements*
- *Part 2: Anchorage strength requirements*
- *Part 3: Requirements for assemblies*

# Tractors and machinery for agriculture — Seat belts —

## Part 3: Requirements for assemblies

### 1 Scope

This part of ISO 3776 specifies the requirements for pelvic restraint (seat) belt assemblies intended to be used by the operators of agricultural tractors and self-propelled machinery.

NOTE Seat belt assemblies that meet the requirements of UNECE R16:2000, Clause 6, but excluding 6.4 of that regulation, or seat belt assemblies complying with the requirements of SAE J386 are deemed to comply with the requirements of this part of ISO 3776.

### 2 Normative references

The following referenced documents are indispensable for the application of this document. For dated references, only the edition cited applies. For undated references, the latest edition of the referenced document (including any amendments) applies.

ISO 3411, *Earth-moving machinery — Physical dimensions of operators and minimum operator space envelope*

ISO 3776-1, *Tractors and machinery for agriculture — Seat belts — Part 1: Anchorage location requirements*

ISO 3776-2:2007, *Tractors and machinery for agriculture — Seat belts — Part 2: Anchorage strength requirements*

ASTM B117, *Standard Practice for Operating Salt Spray (Fog) Apparatus*

ASTM D756:1993, *Practice for Determination of Weight and Shape Changes of Plastics Under Accelerated Service Conditions*

### 3 Terms and definitions

For the purposes of this document, the following terms and definitions apply.

#### 3.1

##### **anchorage**

provision to transfer forces applied to the seat belt assembly to the structure of the tractor or the machine

[ISO 3776-2]

#### 3.2

##### **creep**

amount of unintentional lengthening of the seat belt assembly loop during use caused by motion of the machine, seat and seat-belted occupant

**3.3  
hardware**

any metal or rigid plastic part of the restraint system

**3.3.1  
buckle and latch plate**

quick release connector which fastens the belt assembly into a loop

**3.3.2  
attachment hardware**

all load-bearing devices designed for securing the webbing portion of a seat belt assembly to a tractor or agricultural machine structure or intermediate structural component including but not limited to retractors, end fittings, bolts, studs, nuts or other attachment means, but not including those components permanently fixed to the tractor or agricultural machine

NOTE If the seat belt is attached to the seat, the seat is not considered to be attachment hardware.

**3.3.3  
adjustment hardware**

mechanisms designed for adjusting the belt assembly to fit the user, including such devices that may be integral with a buckle, attachment mechanism, or retractor

**3.4  
loop**

complete seat belt assembly as it would be installed around the seat occupant

**3.5  
polyester yarn**

yarn spun from polyethylene terephthalate

**3.6  
retractor**

device for storing all or part of the strap material of a seat belt assembly

**3.7  
roping**

tendency of a piece of material to twist upon itself or roll up transversely, remaining in the form of a rope instead of staying in its original strap form

**3.8  
seat belt assembly**

belt, including any buckle, length adjustor, retractor, and means for securing to an anchorage, that fastens across the pelvic area to provide pelvic restraint during operation and roll-over conditions

[ISO 3776-2]

## **4 Requirements**

### **4.1 General**

#### **4.1.1 Single occupancy**

A seat belt assembly shall be designed for use by only one person and at any one time.

#### **4.1.2 Release**

A seat belt assembly shall be provided with a buckle or latch readily accessible to the occupant, and designed to provide easy and rapid release of the assembly with a single motion. It shall also be capable of being



released with either hand, bare or gloved. The buckle shall be designed to minimize the possibility of accidental release due to operator movement, inertia or external forces. Additionally, the buckle shall be in accordance with 4.3 and 4.4.

#### **4.1.3 Adjustment**

The seat belt shall be self-adjusting or readily adjustable by a means within easy reach of the seat occupant. Adjustment to a snug condition shall accommodate in all operating positions an operator in at least the 5<sup>th</sup> to 95<sup>th</sup> percentile as defined in ISO 3411.

#### **4.1.4 Creep**

##### **4.1.4.1 General**

Two seat belt assemblies of the same part number with adjusting devices shall be tested in accordance with 4.1.4.2 and 4.1.4.3.

The creep shall not exceed 25 mm for each adjusting device in the assembly.

The sum of creep amounts for all adjusting devices in the belt assembly shall not exceed 40 mm.

##### **4.1.4.2 Conditions**

Two seat belt assemblies of the same part number shall be conditioned for 24 h at a temperature of  $(20 \pm 5)$  °C and  $(65 \pm 5)$  % relative humidity. The test shall be conducted at a temperature between 15 °C and 30 °C. The test apparatus shall conform to that shown in Figure 1 for tests 1 and 2.

##### **4.1.4.3 Test procedure**

Before starting the tests, complete 20 cycles of the reciprocating motion described in c) to remove initial slack. Mark the force-bearing strap material at each adjuster in preparation for measuring creep.

- a) Mount the belts as shown in Figure 1 for tests 1 and 2.
- b) Apply a 5 kg mass to the lower end of each belt assembly. If there is a free end serving as a reserve strap, it shall not be fastened or clipped to the section subjected to the 5 kg mass.
- c) Apply a reciprocating-motion total amplitude of  $(300 \pm 20)$  mm to the top end of each belt assembly.
- d) Ensure that the strap in the slack position maintains contact with the full length of the body block on the test bench.
- e) Guide the 5 kg mass vertically so as to prevent swaying of the mass and twisting of the belt during testing. The attachment shall be fixed to the 5 kg mass in the same manner as in the tractor or agricultural machine.
- f) Complete 1 000 cycles at a frequency of 0,5 Hz at the reciprocation motion of  $(300 \pm 20)$  mm. The 5 kg mass shall be applied only during the time corresponding to a shift of  $(100 \pm 12)$  mm of each half cycle. See Figure 1.
- g) Measure the distance the strap material has moved at each adjusting device.

Dimensions in millimetres

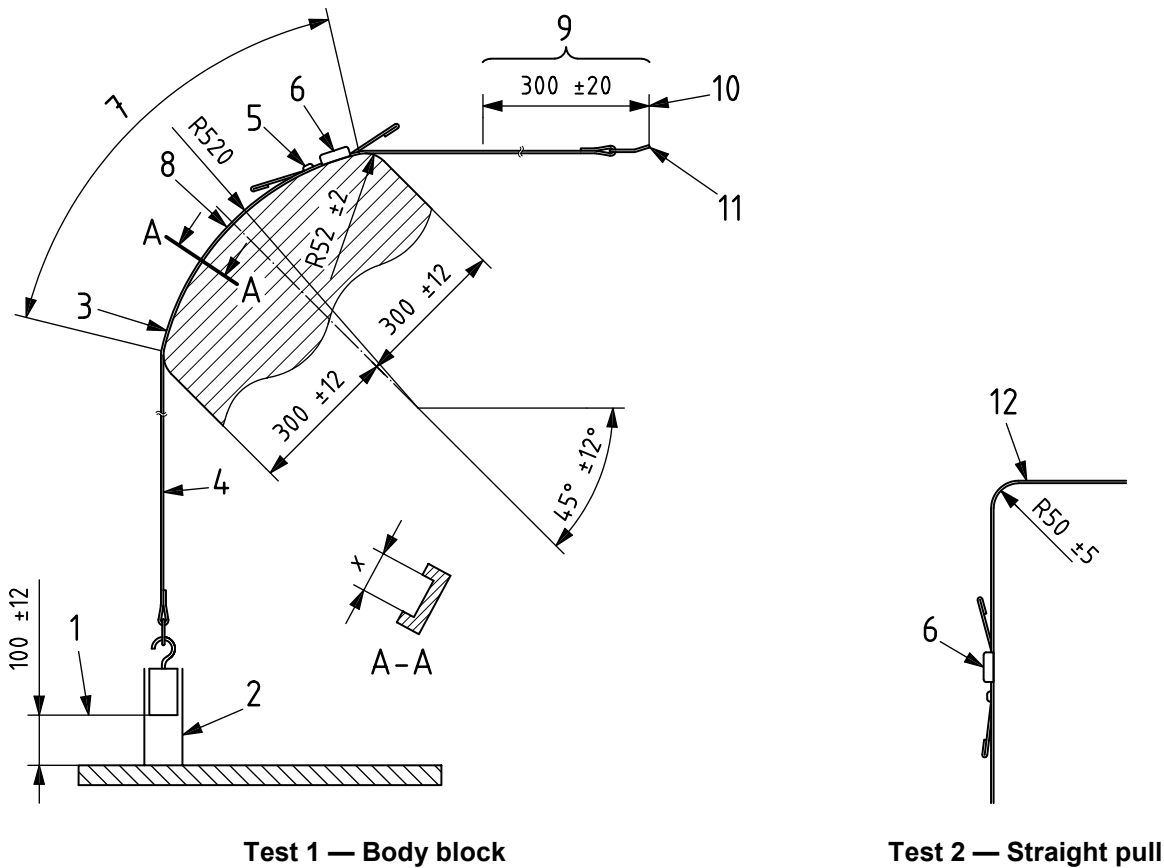

Test 1 — Body block

Test 2 — Straight pull

**Key**

- |   |                          |    |                                   |
|---|--------------------------|----|-----------------------------------|
| 1 | start position           | 7  | arc of travel — 30 cycles minimum |
| 2 | mass guide               | 8  | steel surface                     |
| 3 | maximum travel point 2   | 9  | travel of point 1                 |
| 4 | taut position            | 10 | point 1 (start position)          |
| 5 | point 2 (start position) | 11 | attachment to oscillating device  |
| 6 | buckle assembly          | 12 | fixed surface                     |

**Figure 1 — Creep test apparatus**

**4.1.5 Breaking strength**

**4.1.5.1 Test procedure**

All the components of three seat belt assemblies shall be tested.

- Adjust the pelvic restraint between seat belt anchorages to a length between 914 mm and 1 219 mm, or as near to this length as possible if the design of the pelvic restraint does not permit its adjustment to this length. An automatic locking or emergency locking retractor, when included in a seat belt assembly, shall be locked at the start of the test with a tension in the strapping slightly in excess of the retractile force, in order to keep the retractor locked.
- Orientate the attachment hardware to the strapping as specified in e) below and as shown in Figure 2.
- Apply a tensile force of  $(11,1 \pm 0,1)$  kN to the components in any convenient manner: the extension between anchorages under this force shall not increase by more than 500 mm.

- d) Reduce the tensile force. The buckle release force shall be in accordance with 4.4.3.
- e) Attach the attachment hardware furnished with the seat belt assembly to the anchorage bar. The attaching bolt, with the listed exceptions, shall be parallel to or at an angle of 45° or 90° to the strapping, whichever results in the greatest angle between strapping and attachment hardware. Eye bolts shall be vertical, and the attaching bolts of a seat belt assembly designed for use in specific models of machines shall be installed to produce the maximum angle in use indicated by the installation instructions.

#### 4.1.5.2 Acceptance condition

The complete seat belt assembly, including strapping, straps, buckles, adjustment and attachment hardware and retractors, shall withstand a tensile force of not less than 11,1 kN — i.e. each structural component of the assembly shall withstand a force of 11,1 kN when tested by the procedure of 4.1.5.1.

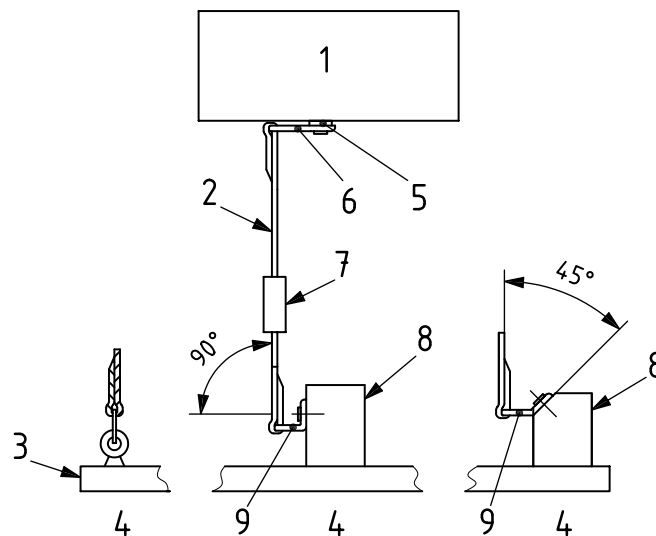

#### Key

1	testing machine	6	swivel plate
2	webbing	7	buckle
3	anchorage bar	8	rigid adapter
4	example attachment	9	angle bracket
5	space washer		

**Figure 2 — Loop force testing machine**

#### 4.1.6 Marking (labelling)

Each conformant seat belt assembly and/or section of the seat belt assembly shall be permanently and legibly labelled with the following:

- reference to this part of ISO 3776 (i.e. “ISO 3776-3:2009”);
- year of manufacture;
- model or style number;
- name or trademark of the manufacturer or importer.

#### 4.1.7 Usage and maintenance instructions

When packaged separately, seat belt assemblies shall be accompanied by written instructions for

- a) installation, including the proper manner of threading the strap into the attachment hardware when threadable hardware is supplied,
- b) correct wearing of the installed assembly, and
- c) proper maintenance (including cleaning procedures) and periodic inspection for wear or damage.

## 4.2 Strap material requirements

### 4.2.1 Material

The strap material shall have resistance to mild acids, alkalies, mildew, aging, moisture and sunlight equal to or better than that of untreated polyester yarn.

### 4.2.2 Stiffness

In order to minimize roping, the strap material shall be woven and/or treated to produce stiffness in the transverse direction. The stiffness shall be effective for the usable life of the strap. The strap shall be flexible in the longitudinal direction to permit adjustment at  $-40\text{ }^{\circ}\text{C}$ .

### 4.2.3 Colour

Preferred colours are those recommended by the strap material manufacturer as being less sensitive to ultraviolet rays.

### 4.2.4 Width

The strap material shall not be less than 46 mm in width when measured under a no-force condition.

### 4.2.5 Ends

The ends shall be protected or treated to prevent unravelling and shall not pull out of the adjustment hardware at maximum size adjustment.

### 4.2.6 Strength — Test procedure

Condition three specimens for at least 24 h in an atmosphere having a relative humidity between 48 % and 67 % and a temperature of  $(23 \pm 2)\text{ }^{\circ}\text{C}$ . After conditioning, the new material shall have a tensile breaking strength of not less than 26 700 N. The testing machine shall be verified to have an error of not more than 1 % in the range of the tensile strength of the strap material. The distance between centres of the grips of the machine at the start of the test shall be between 100 mm and 250 mm. After placing the specimen in the grips, stretch the strap material continuously at a uniform rate to failure. The rate of grip separation shall be 50 mm/min to 100 mm/min. Each failure force value shall be not less than the 26 700 N tensile breaking strength requirement.

### 4.2.7 Elongation

Elongation shall not exceed 20 % at 11 100 N when measured for strap material breaking strength in accordance with 4.2.6.

#### 4.2.8 Abrasion — Test procedure

The strap material from three seat belt assemblies shall be tested for resistance to abrasion by rubbing over the hexagon bar prescribed in Figure 3 as follows.

- a) Mount the strap material in the apparatus shown schematically in Figure 3.
- b) Attach one end of the strap material to a  $(2,3 \pm 0,05)$  kg mass. Pass the strap material over the new abrading edges of the hexagon bar and attach the other end to an oscillating drum having a stroke of 330 mm. Suitable guides shall be used to prevent movement of the strap material along the axis of the hexagonal bar.
- c) Cause the drum to oscillate for 5 000 strokes (or 2 500 cycles) at a rate of  $(60 \pm 2)$  strokes/min [or  $(30 \pm 1)$  cycles/min].
- d) Condition and test the abraded strap material for breaking strength in accordance with 4.2.6. The median value for the breaking strength determined on abraded specimens shall be not less than 20 000 N tensile strength.

Dimensions in millimetres

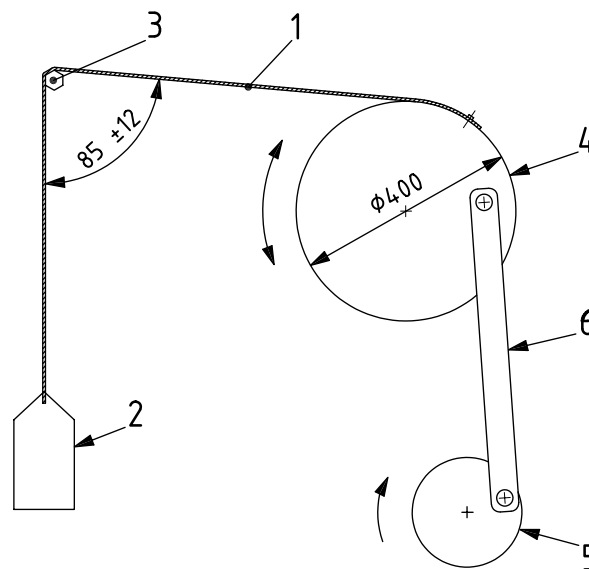

#### Key

- 1 strap material
- 2 mass
- 3 hex rod <sup>a</sup>
- 4 drum
- 5 crank
- 6 crank arm

<sup>a</sup> Steel, Rockwell hardness B-97 to B-101, cold drawn finish, size  $(6,35 \pm 0,1)$  mm, radius on edges  $0,5 \pm 0,1$ .

**Figure 3 — Abrasion test for strap material**

### 4.3 Hardware requirements

#### 4.3.1 General

##### 4.3.1.1 Hardware

All hardware which under normal usage will come into contact with an occupant, the occupant's clothing or the seat belt assembly webbing shall be free from burrs and sharp edges, and shall be designed and/or located in the assembly so that the possibility of injury to the occupant is minimized.

##### 4.3.1.2 Buckle release mechanism

The buckle release mechanism shall be designed to minimize the possibility of inadvertent release. A buckle with the release mechanism in the normal position shall have only one opening into which the latch plate can be inserted, located on the end of the buckle designed to receive and latch the latch plate.

#### 4.3.2 Corrosion resistance

##### 4.3.2.1 Test method

Three seat belt assemblies shall be submitted to the ASTM B117 salt spray test, for a duration of

- a) 50 h for all attachment hardware at or near the floor, consisting of two periods of 24 h exposure to salt spray each followed by 1 h drying,
- b) 25 h for all other hardware, consisting of one period of 24 h of exposure to salt spray followed by 1 h drying.

The test need not be performed on attachment hardware made from corrosion-resistant steel containing at least 11,5 % chromium.

In the salt spray chamber, orientate the parts from the three assemblies differently, at those orientations most likely to develop corrosion on the larger areas. At the end of the 1 h drying interval at the conclusion of the test, wash the seat belt assembly thoroughly with tap water to completely remove the salt.

After drying for at least 24 h under ambient laboratory conditions, examine:

- attachment hardware for ferrous corrosion on significant surfaces, i.e. surfaces that can be contacted by a sphere 19 mm in diameter;
- other hardware for ferrous and nonferrous corrosion that could be transferred either directly or by means of the webbing to a person or his or her clothing during use of a seat belt assembly that incorporated the hardware.

##### 4.3.2.2 Acceptance conditions

The attachment hardware of a seat belt assembly subjected to the test given in 4.3.2.1 shall be free of ferrous corrosion on significant surfaces, except for permissible ferrous corrosion at peripheral edges.

The surfaces of seat belt assembly buckles and metallic parts other than those of the attachment hardware shall be free of ferrous or nonferrous corrosion that can be transferred either directly or by means of webbing to the occupant or his or her clothing.

### 4.3.3 Temperature resistance

Subject three seat belt assemblies having plastic or non-metallic hardware to the conditions prescribed in ASTM D756:1993, procedure D. The dimension and weight measurements shall be omitted. Buckles shall be unlatched during conditioning. After conditioning, the hardware parts shall be used for all applicable assembly tests. When subjected to these conditions, the plastic or other non-metallic hardware parts of a seat belt assembly shall not deteriorate in any manner that could cause the seat belt assembly to operate improperly or fail to comply with the requirements of 4.1.2, 4.1.3, and 4.1.4.

### 4.3.4 Attachment hardware

#### 4.3.4.1 Design

The attachment hardware shall be designed to prevent attaching bolts and other parts from becoming inadvertently disengaged from the tractor or agricultural machine.

Attaching bolts shall be as specified in ISO 3776-1.

#### 4.3.4.2 Strength

Attaching (mounting) bolts shall be tested in accordance with ISO 3776-2 and shall withstand the forces specified therein.

End fittings (mounting brackets) shall be tested on equipment similar to that shown in Figure 3 and shall withstand a tensile force of 11 100 N. During testing, the attaching bolts shall be parallel to or at an angle of 45° or 90° to the strap material, whichever results in an angle nearest to 90° between the strap material and the end fitting, excepting eye bolts, which shall be mounted vertically.

### 4.3.5 Adjustment hardware

Any adjustment shall be capable of being made with gloved hands.

### 4.3.6 Retractors

Retractors shall meet the seat belt assembly strength requirements of 4.1.5. When a locking retractor is included in a seat belt assembly, it shall be locked at the start of the assembly strength test. A seat belt assembly utilizing a non-locking retractor shall have the strap material fully extended from the retractor at the start of the assembly strength test.

## 4.4 Additional requirements for buckles

### 4.4.1 Buckle compression

#### 4.4.1.1 Procedure

The buckle of the seat belt assembly shall be subjected to a compressive force of  $(1\ 780 \pm 90)$  N applied

- anywhere on the longitudinal centreline of the buckle, and
- anywhere along lines at approximately 60° to this centreline, with the point of intersection of these lines centred over the release mechanism.

Apply the force through a cylindrical bar 19 mm in diameter, at least 100 mm long, and curved to a radius of 150 mm (see Figure 4). Place the bar with its longitudinal centreline directly above the lines through the longitudinal centreline of the buckle and at 60° to it.

Buckles from these seat belt assemblies shall be tested as follows:

- a) assemble the buckle and latch plate and apply a tensile force of  $(333 \pm 22)$  N to the connected assembly during the application of the compressive force;
- b) disengage the latch plate from the buckle and again apply the compressive force to the buckle.

#### 4.4.1.2 Acceptance condition

After removal of the compressive force, the buckle shall be operable and meet the applicable acceptance criteria of 4.4.2 and 4.4.3.

Dimensions in millimetres

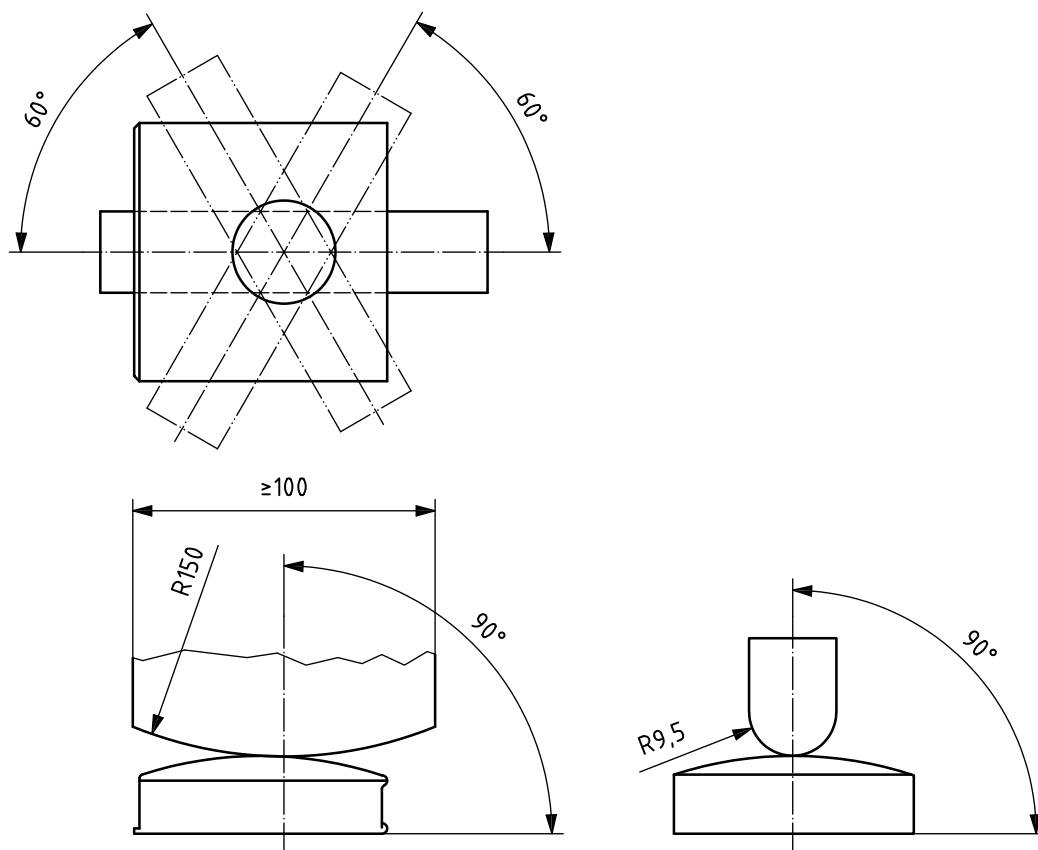

Figure 4 — Buckle compression

#### 4.4.2 Buckle latch operation

##### 4.4.2.1 Procedure

The buckles from three seat belt assemblies shall be fully latched with their latch plates and unlatched at least 10 times.

Then each buckle, with the latch plate withdrawn from the buckle, shall be clamped or firmly held against a solid surface so as to permit normal movement of the buckle parts without movement of the buckle assembly. Move the release mechanism 200 times through the maximum possible travel against its stop with a force of  $(133 \pm 13)$  N and at a rate not exceeding 30 cycles/min, while actuating the mechanism in a manner that simulates actual usage.



After completion of this portion of the test, the 133 N force shall be reduced to a force of magnitude just sufficient to assure full travel to the stop for an additional 10 000 cycles.

#### **4.4.2.2 Acceptance conditions**

The buckle-latch plate assembly shall not fail, gall, nor wear to an extent that normal latching and unlatching is impaired.

The buckle shall be examined to determine whether partial engagement is possible by means of any technique representative of actual use. If partial engagement is possible, the maximum force of separation shall not exceed 22 N.

#### **4.4.3 Release**

##### **4.4.3.1 Procedure**

Three samples of a given buckle shall be tested.

The buckle shall be located so that it does not touch the rollers of the test machine during the test; however, to facilitate testing, the buckle should be between the rollers or near a roller in one leg of the loop. Subject the buckle to the force specified 4.1.5, then reduce and maintain at a tensile force of 335 N. Measure the buckle release force by applying a force on the buckle in a manner and direction typical of that which would be employed by a seat belt user.

A buckle designed for lift lever application of buckle release shall at least permit the insertion of a cylinder 10 mm in diameter and 38 mm in length to at least the midpoint of the cylinder along the lift lever's entire length in the actuating portion of the buckle release. Apply the release force on the centreline of the buckle lever or finger tab in a direction that produces maximum releasing effect.

Buckles having other designs for release shall have adequate access to actuate release.

##### **4.4.3.2 Acceptance condition**

The buckle of the seat belt assembly shall release when a force of not more than 130 N is applied to the releasing mechanism.

#### **4.4.4 Padding**

If a buckle is used that is less than the width of the strap material, in an area that could be uncomfortable to the operator, a pad shall be provided under the buckle. This pad shall cover the entire buckle area and shall be the full width of the strap. It shall be permanently fastened to the assembly so that it is not injurious or uncomfortable to the operator, does not hinder operation of any part of the seat belt, and does not present any rough surfaces to the operator's clothing.

#### **4.4.5 Adjustment force**

##### **4.4.5.1 Procedure**

Three buckles or other manual adjusting devices normally used to adjust the length of the assembly shall be tested. The test shall be conducted within 1 h after conditioning under laboratory ambient conditions. Without load on the anchor end, draw the webbing through the adjusting device at a rate of  $(500 \pm 50)$  mm/min, and measure the maximum force to the nearest 1 N after the first 25 mm of webbing movement. The webbing shall be pre-cycled 10 times prior to measurement.

##### **4.4.5.2 Acceptance condition**

The maximum force shall not exceed 50 N.

#### 4.4.6 Tilt-lock adjustment

##### 4.4.6.1 Procedure

This test shall be conducted on buckles or other manual adjusting devices employing a tilt-lock feature to adjust the length of the assembly, using webbing intended for use in the adjusting device. Three buckles or devices shall be tested within 1 h after conditioning the webbing for 4 h at the laboratory ambient conditions. Orientate the base of the adjustment mechanism and the anchor end of the webbing in planes normal to one another with the webbing vertical as shown in Figure 5. The adjustment mechanism base shall be horizontal and downward at the start of test. Draw the webbing through the adjustment mechanism so as to increase belt length at a rate of  $(500 \pm 50)$  mm/min, while the plane of the base is rotated at a speed of  $(1,1 \pm 0,2)$  r/min in a direction so as to lock the webbing. Stop rotation when the webbing locks and subsequently supports a 9 kg mass, but continue the pull on the webbing until there is resistance to at least 89 N.

Measure the locking angle between the anchor end of the webbing and the base of the adjustment mechanism to the nearest degree. The webbing shall be pre-cycled 10 times prior to measurement.

##### 4.4.6.2 Acceptance condition

The webbing shall lock at an angle of not less than  $30^\circ$ .

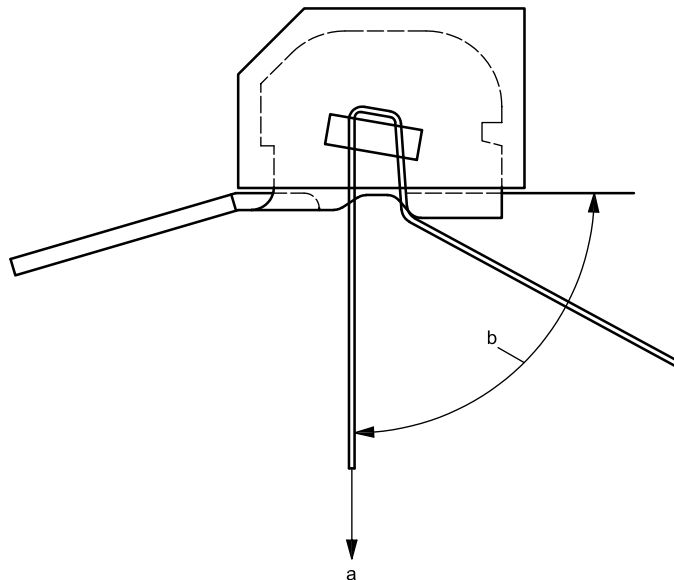

<sup>a</sup> Direction of webbing displacement and tensile load (normal to base of adjustment mechanism at its initial position).

<sup>b</sup> Angle of measurement of locking angle between anchor end of webbing and base of adjustment mechanism (initial position for test set-up is  $90^\circ$ ).

**Figure 5 — Tilt-lock adjustment**

## Bibliography

- [1] SAE J386:2006, *Operator Restraint System for Off-Road Work Machines*
- [2] UNECE R16:2000, *Uniform provisions concerning the approval of safety-belts and restraint systems for occupants of power-driven vehicles, vehicles equipped with safety-belts* <sup>1)</sup>

---

1) Regulation of the United Nations Economic Commission for Europe.





---

## BSI - British Standards Institution

BSI is the independent national body responsible for preparing British Standards. It presents the UK view on standards in Europe and at the international level. It is incorporated by Royal Charter.

### Revisions

British Standards are updated by amendment or revision. Users of British Standards should make sure that they possess the latest amendments or editions.

It is the constant aim of BSI to improve the quality of our products and services. We would be grateful if anyone finding an inaccuracy or ambiguity while using this British Standard would inform the Secretary of the technical committee responsible, the identity of which can be found on the inside front cover. Tel: +44 (0)20 8996 9000. Fax: +44 (0)20 8996 7400.

BSI offers members an individual updating service called PLUS which ensures that subscribers automatically receive the latest editions of standards.

### Buying standards

Orders for all BSI, international and foreign standards publications should be addressed to Customer Services. Tel: +44 (0)20 8996 9001. Fax: +44 (0)20 8996 7001 Email: [orders@bsigroup.com](mailto:orders@bsigroup.com) You may also buy directly using a debit/credit card from the BSI Shop on the Website <http://www.bsigroup.com/shop>

In response to orders for international standards, it is BSI policy to supply the BSI implementation of those that have been published as British Standards, unless otherwise requested.

### Information on standards

BSI provides a wide range of information on national, European and international standards through its Library and its Technical Help to Exporters Service. Various BSI electronic information services are also available which give details on all its products and services. Contact Information Centre. Tel: +44 (0)20 8996 7111 Fax: +44 (0)20 8996 7048 Email: [info@bsigroup.com](mailto:info@bsigroup.com)

Subscribing members of BSI are kept up to date with standards developments and receive substantial discounts on the purchase price of standards. For details of these and other benefits contact Membership Administration. Tel: +44 (0)20 8996 7002 Fax: +44 (0)20 8996 7001 Email: [membership@bsigroup.com](mailto:membership@bsigroup.com)

Information regarding online access to British Standards via British Standards Online can be found at <http://www.bsigroup.com/BSOL>

Further information about BSI is available on the BSI website at <http://www.bsigroup.com>

### Copyright

Copyright subsists in all BSI publications. BSI also holds the copyright, in the UK, of the publications of the international standardization bodies. Except as permitted under the Copyright, Designs and Patents Act 1988 no extract may be reproduced, stored in a retrieval system or transmitted in any form or by any means – electronic, photocopying, recording or otherwise – without prior written permission from BSI.

This does not preclude the free use, in the course of implementing the standard, of necessary details such as symbols, and size, type or grade designations. If these details are to be used for any other purpose than implementation then the prior written permission of BSI must be obtained.

Details and advice can be obtained from the Copyright and Licensing Manager. Tel: +44 (0)20 8996 7070 Email: [copyright@bsigroup.com](mailto:copyright@bsigroup.com)