

BS ISO 3467:2016



BSI Standards Publication

Machine taper pin reamers with Morse taper shanks

bsi.

...making excellence a habit.™

National foreword

This British Standard is the UK implementation of ISO 3467:2016.

The UK participation in its preparation was entrusted to Technical Committee MTE/18, Tools tips and inserts for cutting applications.

A list of organizations represented on this committee can be obtained on request to its secretary.

This publication does not purport to include all the necessary provisions of a contract. Users are responsible for its correct application.

© The British Standards Institution 2016.
Published by BSI Standards Limited 2016

ISBN 978 0 580 90182 9

ICS 25.100.30

Compliance with a British Standard cannot confer immunity from legal obligations.

This British Standard was published under the authority of the Standards Policy and Strategy Committee on 31 March 2016.

Amendments/corrigenda issued since publication

Date	Text affected
------	---------------

INTERNATIONAL
STANDARD

BS ISO 3467:2016

ISO
3467

Second edition
2016-03-01

**Machine taper pin reamers with
Morse taper shanks**

*Alésoirs à machine pour trous de goupilles coniques, à queue cône
Morse*



Reference number
ISO 3467:2016(E)

© ISO 2016



COPYRIGHT PROTECTED DOCUMENT

© ISO 2016, Published in Switzerland

All rights reserved. Unless otherwise specified, no part of this publication may be reproduced or utilized otherwise in any form or by any means, electronic or mechanical, including photocopying, or posting on the internet or an intranet, without prior written permission. Permission can be requested from either ISO at the address below or ISO's member body in the country of the requester.

ISO copyright office
Ch. de Blandonnet 8 • CP 401
CH-1214 Vernier, Geneva, Switzerland
Tel. +41 22 749 01 11
Fax +41 22 749 09 47
copyright@iso.org
www.iso.org

Contents

	Page
Foreword	iv
1 Scope	1
2 Dimensions	1
Annex A (informative) Relationship between designations in this International Standard and ISO 13399	3
Bibliography	4

Foreword

ISO (the International Organization for Standardization) is a worldwide federation of national standards bodies (ISO member bodies). The work of preparing International Standards is normally carried out through ISO technical committees. Each member body interested in a subject for which a technical committee has been established has the right to be represented on that committee. International organizations, governmental and non-governmental, in liaison with ISO, also take part in the work. ISO collaborates closely with the International Electrotechnical Commission (IEC) on all matters of electrotechnical standardization.

The procedures used to develop this document and those intended for its further maintenance are described in the ISO/IEC Directives, Part 1. In particular the different approval criteria needed for the different types of ISO documents should be noted. This document was drafted in accordance with the editorial rules of the ISO/IEC Directives, Part 2 (see www.iso.org/directives).

Attention is drawn to the possibility that some of the elements of this document may be the subject of patent rights. ISO shall not be held responsible for identifying any or all such patent rights. Details of any patent rights identified during the development of the document will be in the Introduction and/or on the ISO list of patent declarations received (see www.iso.org/patents).

Any trade name used in this document is information given for the convenience of users and does not constitute an endorsement.

For an explanation on the meaning of ISO specific terms and expressions related to conformity assessment, as well as information about ISO's adherence to the WTO principles in the Technical Barriers to Trade (TBT) see the following URL: [Foreword - Supplementary information](#).

The committee responsible for this document is ISO/TC 29, *Small tools*, Subcommittee SC 9, *Cutting tools with defined cutting edges, cutting items*.

This second edition cancels and replaces the first edition (ISO 3467:1975), of which it constitutes a minor revision.

Machine taper pin reamers with Morse taper shanks

1 Scope

This International Standard lays down the dimensions of machine taper pin reamers with Morse taper shanks.

It covers only metric dimensions, which are the only recommended dimensions in the future for these types of reamers.

The reamers have been designed to produce holes for taper pins manufactured to ISO 2339, in the range 5 mm to 50 mm nominal diameter.

Unless otherwise stated, these reamers will be right-hand cutting.

The flutes may be straight or left-hand spiral, at the option of the manufacturer.

Hand taper pin reamers are dealt with in ISO 3465, and machine taper pin reamers with parallel shanks in ISO 3466.

2 Dimensions

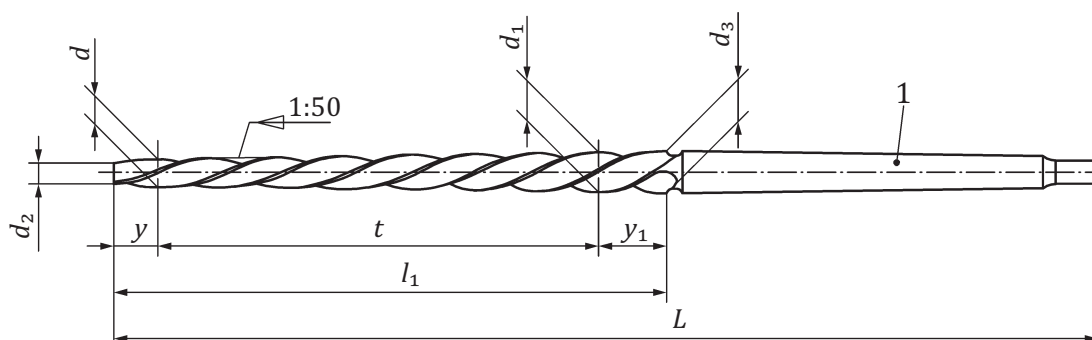

Key

1 Morse taper

Figure 1

Table 1

Dimensions in millimetres

<i>d</i> nominal	<i>d</i> ₁	<i>t</i>	<i>y</i>	<i>y</i> ₁	<i>d</i> ₂	<i>d</i> ₃	<i>l</i> ₁	<i>L</i>	Morse taper no.
5	6,2	60	5	8	4,9	6,36	73	155	1
6	7,8	90	5	10	5,9	8,00	105	187	1
8	10,6	130	5	10	7,9	10,80	145	227	1
10	13,2	160	5	10	9,9	13,40	175	257	1
12	15,6	180	10	20	11,8	16,00	210	315	2
16	20,0	200	10	20	15,8	20,40	230	335	2
20	24,4	220	10	20	19,8	24,80	250	377	3
25	29,8	240	15	45	24,7	30,70	300	427	3
30	35,2	260	15	45	29,7	36,10	320	475	4
40	45,6	280	15	45	39,7	46,50	340	495	4
50	56,0	300	15	45	49,7	56,90	360	550	5

Annex A (informative)

Relationship between designations in this International Standard and ISO 13399

For relationship between designations in this International Standard and preferred symbols according to ISO 13399, see [Table A.1](#).

Table A.1 — Relationship between designations in this International Standard and ISO 13399 series

Symbol in ISO 3467	Reference in ISO 3467	Property name in ISO 13399	Symbol in ISO 13399	Reference in ISO 13399
d	Figure 1 and Table 1	cutting diameter	DC	ISO/TS 13399-3 71CE7A96D9F7D
d_1	Figure 1 and Table 1	taper diameter largest	DTAX	ISO/TS 13399-3 726E3AA6C4A1C
d_2	Figure 1 and Table 1	interference cutting diameter	DCINTF	ISO/TS 13399-3 726E2FCC0EC78
d_3	Figure 1 and Table 1	cutting diameter maximum	DCX	ISO/TS 13399-3 71D084656CE32
L	Figure 1 and Table 1	overall length	OAL	ISO/TS 13399-3 71D078EB7C086
l_1	Figure 1 and Table 1	usable length	LU	ISO/TS 13399-3 71EBB33490FDA
t	Figure 1 and Table 1	taper length	—	—
y	Figure 1 and Table 1	distance reference point PK	LDC	ISO/TS 13399-3 726E3AAAF99A3
y_1	Figure 1 and Table 1	—	—	—
Morse taper no.	Table 1	connection size code machine side	CZCMS	ISO/TS 13399-3 727C2BCCC5596
1:50	Figure 1	taper gradient	TG	ISO/TS 13399-3 71CEAEC02FEBD

Bibliography

- [1] ISO 286, *Geometrical product specifications (GPS) — ISO code system for tolerances on linear sizes*
- [2] ISO 296, *Machine tools — Self-holding tapers for tool shanks*
- [3] ISO 2339, *Taper pins, unhardened*
- [4] ISO 3465, *Hand taper pin reamers*
- [5] ISO 3466, *Machine taper pin reamers with Morse taper shanks*
- [6] ISO/TS 13399-3:2014, *Cutting tool data representation and exchange — Part 3: Reference dictionary for tool items*

British Standards Institution (BSI)

BSI is the national body responsible for preparing British Standards and other standards-related publications, information and services.

BSI is incorporated by Royal Charter. British Standards and other standardization products are published by BSI Standards Limited.

About us

We bring together business, industry, government, consumers, innovators and others to shape their combined experience and expertise into standards-based solutions.

The knowledge embodied in our standards has been carefully assembled in a dependable format and refined through our open consultation process. Organizations of all sizes and across all sectors choose standards to help them achieve their goals.

Information on standards

We can provide you with the knowledge that your organization needs to succeed. Find out more about British Standards by visiting our website at bsigroup.com/standards or contacting our Customer Services team or Knowledge Centre.

Buying standards

You can buy and download PDF versions of BSI publications, including British and adopted European and international standards, through our website at bsigroup.com/shop, where hard copies can also be purchased.

If you need international and foreign standards from other Standards Development Organizations, hard copies can be ordered from our Customer Services team.

Subscriptions

Our range of subscription services are designed to make using standards easier for you. For further information on our subscription products go to bsigroup.com/subscriptions.

With **British Standards Online (BSOL)** you'll have instant access to over 55,000 British and adopted European and international standards from your desktop. It's available 24/7 and is refreshed daily so you'll always be up to date.

You can keep in touch with standards developments and receive substantial discounts on the purchase price of standards, both in single copy and subscription format, by becoming a **BSI Subscribing Member**.

PLUS is an updating service exclusive to BSI Subscribing Members. You will automatically receive the latest hard copy of your standards when they're revised or replaced.

To find out more about becoming a BSI Subscribing Member and the benefits of membership, please visit bsigroup.com/shop.

With a **Multi-User Network Licence (MUNL)** you are able to host standards publications on your intranet. Licences can cover as few or as many users as you wish. With updates supplied as soon as they're available, you can be sure your documentation is current. For further information, email bsmusales@bsigroup.com.

Revisions

Our British Standards and other publications are updated by amendment or revision.

We continually improve the quality of our products and services to benefit your business. If you find an inaccuracy or ambiguity within a British Standard or other BSI publication please inform the Knowledge Centre.

Copyright

All the data, software and documentation set out in all British Standards and other BSI publications are the property of and copyrighted by BSI, or some person or entity that owns copyright in the information used (such as the international standardization bodies) and has formally licensed such information to BSI for commercial publication and use. Except as permitted under the Copyright, Designs and Patents Act 1988 no extract may be reproduced, stored in a retrieval system or transmitted in any form or by any means – electronic, photocopying, recording or otherwise – without prior written permission from BSI. Details and advice can be obtained from the Copyright & Licensing Department.

Useful Contacts:

Customer Services

Tel: +44 845 086 9001

Email (orders): orders@bsigroup.com

Email (enquiries): cservices@bsigroup.com

Subscriptions

Tel: +44 845 086 9001

Email: subscriptions@bsigroup.com

Knowledge Centre

Tel: +44 20 8996 7004

Email: knowledgecentre@bsigroup.com

Copyright & Licensing

Tel: +44 20 8996 7070

Email: copyright@bsigroup.com

BSI Group Headquarters

389 Chiswick High Road London W4 4AL UK

