

BS ISO 3338-2:2013



BSI Standards Publication

Cylindrical shanks for milling cutters

Part 2: Dimensional characteristics of flatted cylindrical shanks

bsi.

...making excellence a habit.™

National foreword

This British Standard is the UK implementation of ISO 3338-2:2013. It supersedes BS ISO 3338-2:2007 which is withdrawn.

The UK participation in its preparation was entrusted to Technical Committee MTE/18, Tools tips and inserts for cutting applications.

A list of organizations represented on this committee can be obtained on request to its secretary.

This publication does not purport to include all the necessary provisions of a contract. Users are responsible for its correct application.

© The British Standards Institution 2013. Published by BSI Standards Limited 2013

ISBN 978 0 580 77000 5

ICS 25.100.20

Compliance with a British Standard cannot confer immunity from legal obligations.

This British Standard was published under the authority of the Standards Policy and Strategy Committee on 31 August 2013.

Amendments issued since publication

Date	Text affected
------	---------------

INTERNATIONAL
STANDARD

ISO
3338-2

Seventh edition
2013-08-15

Cylindrical shanks for milling cutters —
Part 2:
Dimensional characteristics of flatted
cylindrical shanks

Queues cylindriques d'outils à fraiser —

Partie 2: Caractéristiques dimensionnelles des queues cylindriques à méplat



Reference number
ISO 3338-2:2013(E)

© ISO 2013



COPYRIGHT PROTECTED DOCUMENT

© ISO 2013

All rights reserved. Unless otherwise specified, no part of this publication may be reproduced or utilized otherwise in any form or by any means, electronic or mechanical, including photocopying, or posting on the internet or an intranet, without prior written permission. Permission can be requested from either ISO at the address below or ISO's member body in the country of the requester.

ISO copyright office
Case postale 56 • CH-1211 Geneva 20
Tel. + 41 22 749 01 11
Fax + 41 22 749 09 47
E-mail copyright@iso.org
Web www.iso.org

Published in Switzerland

Contents

	Page
Foreword	iv
1 Scope	1
2 Normative references	1
3 Dimensions	1
3.1 General.....	1
3.2 WE form — Flatted cylindrical shanks with single flat for diameter, d_1 , of 6 mm to 20 mm..	1
3.3 WE form — Flatted cylindrical shanks with double flat for diameter, d_1 , of 25 mm to 63 mm.....	2
3.4 WN form — Flatted cylindrical shanks with inclined clamping surface.....	3
Annex A (informative) Relationship between the symbols of this part of ISO 3388 and ISO 13399 (all parts)	5
Bibliography	6

Foreword

ISO (the International Organization for Standardization) is a worldwide federation of national standards bodies (ISO member bodies). The work of preparing International Standards is normally carried out through ISO technical committees. Each member body interested in a subject for which a technical committee has been established has the right to be represented on that committee. International organizations, governmental and non-governmental, in liaison with ISO, also take part in the work. ISO collaborates closely with the International Electrotechnical Commission (IEC) on all matters of electrotechnical standardization.

The procedures used to develop this document and those intended for its further maintenance are described in the ISO/IEC Directives, Part 1. In particular the different approval criteria needed for the different types of ISO documents should be noted. This document was drafted in accordance with the editorial rules of the ISO/IEC Directives, Part 2. www.iso.org/directives

Attention is drawn to the possibility that some of the elements of this document may be the subject of patent rights. ISO shall not be held responsible for identifying any or all such patent rights. Details of any patent rights identified during the development of the document will be in the Introduction and/or on the ISO list of patent declarations received. www.iso.org/patents

Any trade name used in this document is information given for the convenience of users and does not constitute an endorsement.

The committee responsible for this document is ISO/TC 29, Subcommittee SC 2, *High speed steel cutting tools and their attachments*.

This seventh edition cancels and replaces the sixth edition (ISO 3338-2:2007), of which it constitutes a minor revision. In particular, an annex giving the relationship between the symbols of this part of ISO 3338 and the symbols according to ISO 13399 (all parts) has been added.

ISO 3338 consists of the following parts, under the general title *Cylindrical shanks for milling cutters*:

- *Part 1: Dimensional characteristics of plain cylindrical shanks*
- *Part 2: Dimensional characteristics of flatted cylindrical shanks*
- *Part 3: Dimensional characteristics of threaded shanks*

Cylindrical shanks for milling cutters —

Part 2:

Dimensional characteristics of flatted cylindrical shanks

1 Scope

This part of ISO 3338 specifies the dimensions of flatted cylindrical shanks for milling cutters, of diameters 6 mm to 20 mm for single-flatted shanks, of 25 mm to 63 mm for double-flatted shanks and of 6 mm to 32 mm for shank with inclined clamping surface. In the case of single-flatted shanks, it is applicable to both single-ended cutters and double-ended cutters, as double-flatted shanks cannot admit single-ended cutters.

The dimensions of plain cylindrical shanks and threaded shanks are given in ISO 3338-1 and ISO 3338-3, respectively.

The two shank types covered by ISO 3338-1 and this part of ISO 3338 have the same dimensional characteristics (diameters and lengths), but different tolerances on diameters, namely:

- h8 for plain cylindrical shanks, commonly used for tools mounted in collets;
- h6 for flatted cylindrical shanks, intended to be mounted in chucks and secured with a clamping screw, and requiring an accuracy adjustment.

2 Normative references

The following documents, in whole or in part, are normatively referenced in this document and are indispensable for its application. For undated references, the latest edition of the referenced document (including any amendments) applies.

ISO 2768-1, *General tolerances — Part 1: Tolerances for linear and angular dimensions without individual tolerance indications*

3 Dimensions

3.1 General

All dimensions and tolerances are given in millimetres. Tolerances not specified shall be of tolerance class “m” in accordance with ISO 2768-1.

3.2 WE form — Flatted cylindrical shanks with single flat for diameter, d_1 , of 6 mm to 20 mm

The dimensions of flatted cylindrical shanks with single flat shall be in accordance with the dimensions shown in [Figure 1](#) and given in [Table 1](#).

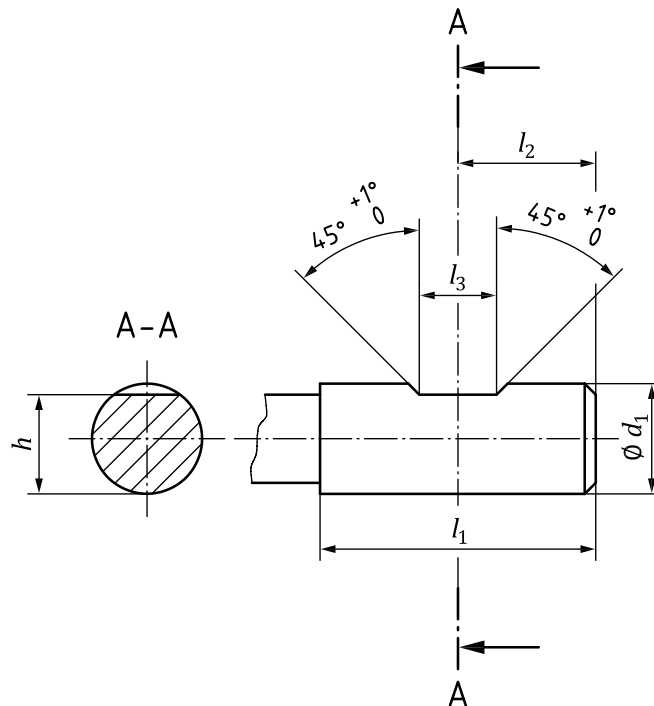

Figure 1 — WE Form — Flatted cylindrical shanks with single flat

3.3 WE form — Flatted cylindrical shanks with double flat for diameter, d_1 , of 25 mm to 63 mm

The dimensions of flatted cylindrical shanks with double flat shall be in accordance with the dimensions shown in [Figure 2](#) and [Table 1](#).

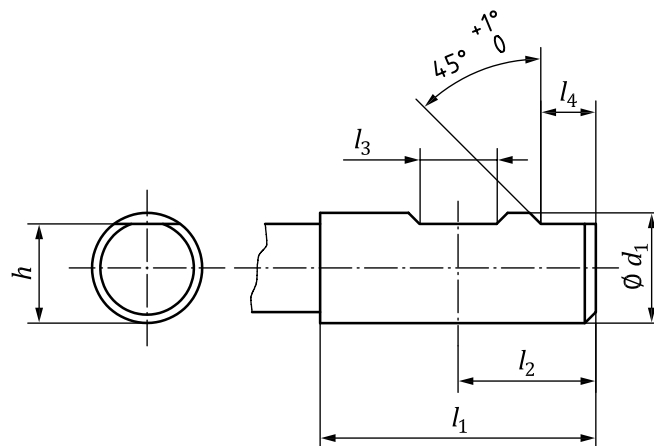

Figure 2 — WE form — Flatted cylindrical shanks with double flat

Table 1 — WE form — Flatted cylindrical shanks with single or double flat

d_1 h6	l_1 $+2$ 0	l_2 0 -1	l_3 $+0,05$ 0	l_4 $+1$ 0	h h11
6	36	18	4,2	-	4,8
8			5,5		6,6
10	40	20	7		8,4
12	45	22,5	8		10,4
14					12,7
16	48	24	10		14,2
18					16,2
20	50	25	11	18,2	
25	56	32	12	17	23
32	60	36	14	19	30
40	70	40			38
50	80	45	18	23	47,8
63	90	50			60,8

3.4 WN form — Flatted cylindrical shanks with inclined clamping surface

The dimensions of flatted cylindrical shanks with inclined clamping surface shall be in accordance with the dimensions shown in in [Figure 3](#) and [Table 2](#).

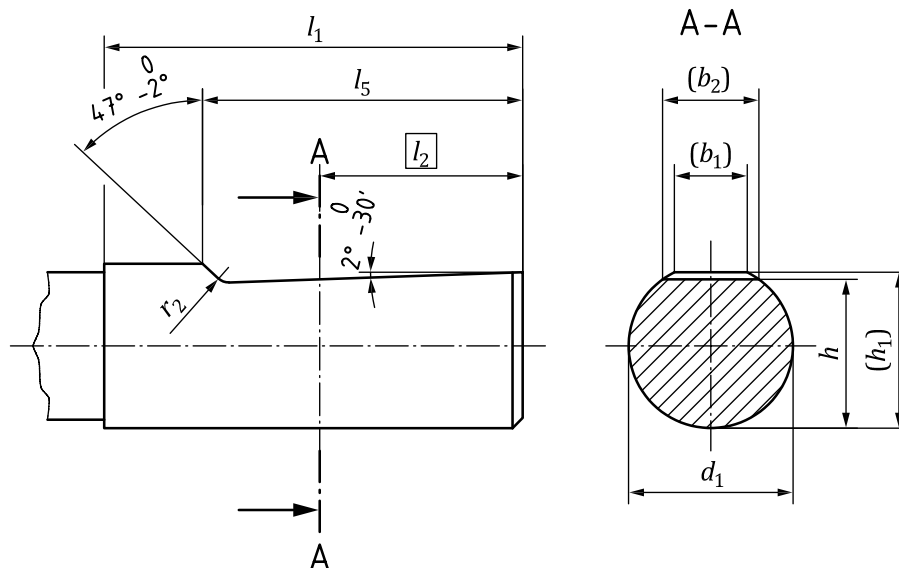

Figure 3 — WN form — Flatted cylindrical shanks with inclined clamping surface

Table 2 — WN form — Flatted cylindrical shanks with inclined clamping surface

d_1 h6	l_1 $+2$ 0	l_2	l_5 0 -1	h h11	h_1	b_1	b_2	r_2
6	36	18	25	4,8	5,4	3,5	4,8	1,2
8				6,6	7,2	4,7	6,1	
10	40	20	28	8,4	9,1	5,7	7,3	
12	45	22,5	33	10,4	11,2	6	8,2	
14				12,7	-	-	8,1	
16	48	24	36	14,2	15	7,6	10,1	
18				16,2	-	-	10,8	
20	50	25	38	18,2	19,1	8,4	11,5	
25	56	32	44	23	24,1	9,3	13,6	
32	60	36	48	30	31,2	9,9	15,5	

Annex A (informative)

Relationship between the symbols of this part of ISO 3388 and ISO 13399 (all parts)

For the relationship between the symbols of this part of ISO 3388 and symbols according to the ISO 13399 series, see [Table A.1](#).

Table A.1 — Relationship between symbols in this part of ISO 3388 and ISO 13399 (all parts)

Symbol in this part of ISO 3338 (ISO 3338-2)	Reference in this part of ISO 3338 (ISO 3338-2)	Property name in the ISO 13399 series	Symbol in the ISO 13399 series	Reference in the ISO 13399 series BSU code
b_1	Not specified	Not specified	Not specified	Not specified
b_2	Not specified	Not specified	Not specified	Not specified
d_1	Figure 1 , Figure 2 and Figure 3	Shank diameter	DMM	ISO/TS 13399-3 71CF29862B277
h	Not specified	Not specified	Not specified	Not specified
h_1	Not specified	Not specified	Not specified	Not specified
l_1	Figure 1 , Figure 2 and Figure 3	Shank length	LS	ISO/TS 13399-3 71CF298870946
l_2	Not specified	Not specified	Not specified	Not specified
l_3	Not specified	Not specified	Not specified	Not specified
l_4	Not specified	Not specified	Not specified	Not specified
r_2	Not specified	Not specified	Not specified	Not specified

Bibliography

- [1] ISO 3338-1, *Cylindrical shanks for milling cutters — Part 1: Dimensional characteristics of plain cylindrical shanks*
- [2] ISO 3338-3, *Cylindrical shanks for milling cutters — Part 3: Dimensional characteristics of threaded shanks*

British Standards Institution (BSI)

BSI is the national body responsible for preparing British Standards and other standards-related publications, information and services.

BSI is incorporated by Royal Charter. British Standards and other standardization products are published by BSI Standards Limited.

About us

We bring together business, industry, government, consumers, innovators and others to shape their combined experience and expertise into standards-based solutions.

The knowledge embodied in our standards has been carefully assembled in a dependable format and refined through our open consultation process. Organizations of all sizes and across all sectors choose standards to help them achieve their goals.

Information on standards

We can provide you with the knowledge that your organization needs to succeed. Find out more about British Standards by visiting our website at bsigroup.com/standards or contacting our Customer Services team or Knowledge Centre.

Buying standards

You can buy and download PDF versions of BSI publications, including British and adopted European and international standards, through our website at bsigroup.com/shop, where hard copies can also be purchased.

If you need international and foreign standards from other Standards Development Organizations, hard copies can be ordered from our Customer Services team.

Subscriptions

Our range of subscription services are designed to make using standards easier for you. For further information on our subscription products go to bsigroup.com/subscriptions.

With **British Standards Online (BSOL)** you'll have instant access to over 55,000 British and adopted European and international standards from your desktop. It's available 24/7 and is refreshed daily so you'll always be up to date.

You can keep in touch with standards developments and receive substantial discounts on the purchase price of standards, both in single copy and subscription format, by becoming a **BSI Subscribing Member**.

PLUS is an updating service exclusive to BSI Subscribing Members. You will automatically receive the latest hard copy of your standards when they're revised or replaced.

To find out more about becoming a BSI Subscribing Member and the benefits of membership, please visit bsigroup.com/shop.

With a **Multi-User Network Licence (MUNL)** you are able to host standards publications on your intranet. Licences can cover as few or as many users as you wish. With updates supplied as soon as they're available, you can be sure your documentation is current. For further information, email bsmusales@bsigroup.com.

BSI Group Headquarters

389 Chiswick High Road London W4 4AL UK

Revisions

Our British Standards and other publications are updated by amendment or revision.

We continually improve the quality of our products and services to benefit your business. If you find an inaccuracy or ambiguity within a British Standard or other BSI publication please inform the Knowledge Centre.

Copyright

All the data, software and documentation set out in all British Standards and other BSI publications are the property of and copyrighted by BSI, or some person or entity that owns copyright in the information used (such as the international standardization bodies) and has formally licensed such information to BSI for commercial publication and use. Except as permitted under the Copyright, Designs and Patents Act 1988 no extract may be reproduced, stored in a retrieval system or transmitted in any form or by any means – electronic, photocopying, recording or otherwise – without prior written permission from BSI. Details and advice can be obtained from the Copyright & Licensing Department.

Useful Contacts:

Customer Services

Tel: +44 845 086 9001

Email (orders): orders@bsigroup.com

Email (enquiries): cservices@bsigroup.com

Subscriptions

Tel: +44 845 086 9001

Email: subscriptions@bsigroup.com

Knowledge Centre

Tel: +44 20 8996 7004

Email: knowledgecentre@bsigroup.com

Copyright & Licensing

Tel: +44 20 8996 7070

Email: copyright@bsigroup.com



...making excellence a habit.™