

BS ISO 3303-2:2012



BSI Standards Publication

# Rubber- or plastics-coated fabrics — Determination of bursting strength

Part 2: Hydraulic method

**bsi.**

...making excellence a habit.™

**National foreword**

This British Standard is the UK implementation of ISO 3303-2:2012.

The UK participation in its preparation was entrusted to Technical Committee TCI/69, Footwear, leather and coated fabrics.

A list of organizations represented on this committee can be obtained on request to its secretary.

This publication does not purport to include all the necessary provisions of a contract. Users are responsible for its correct application.

© The British Standards Institution 2012. Published by BSI Standards Limited 2012

ISBN 978 0 580 76966 5

ICS 59.080.40

**Compliance with a British Standard cannot confer immunity from legal obligations.**

This British Standard was published under the authority of the Standards Policy and Strategy Committee on 30 September 2012.

**Amendments issued since publication**

Date	Text affected
------	---------------

---

---

---

**Rubber- or plastics-coated fabrics —  
Determination of bursting strength —**

**Part 2:  
Hydraulic method**

*Supports textiles revêtus de caoutchouc ou de plastique —  
Détermination de la résistance à l'éclatement —*

*Partie 2: Méthode hydraulique*





**COPYRIGHT PROTECTED DOCUMENT**

© ISO 2012

All rights reserved. Unless otherwise specified, no part of this publication may be reproduced or utilized in any form or by any means, electronic or mechanical, including photocopying and microfilm, without permission in writing from either ISO at the address below or ISO's member body in the country of the requester.

ISO copyright office  
Case postale 56 • CH-1211 Geneva 20  
Tel. + 41 22 749 01 11  
Fax + 41 22 749 09 47  
E-mail [copyright@iso.org](mailto:copyright@iso.org)  
Web [www.iso.org](http://www.iso.org)

Published in Switzerland

# Contents

Page

Foreword .....	iv
Introduction .....	v
1 Scope .....	1
2 Normative references .....	1
3 Principle .....	1
4 Apparatus .....	1
5 Calibration .....	4
6 Sampling .....	4
7 Preparation of test pieces .....	4
8 Time-interval between manufacture and testing .....	4
9 Conditioning of test pieces .....	4
10 Procedure .....	5
11 Test report .....	5
Bibliography .....	6

## Foreword

ISO (the International Organization for Standardization) is a worldwide federation of national standards bodies (ISO member bodies). The work of preparing International Standards is normally carried out through ISO technical committees. Each member body interested in a subject for which a technical committee has been established has the right to be represented on that committee. International organizations, governmental and non-governmental, in liaison with ISO, also take part in the work. ISO collaborates closely with the International Electrotechnical Commission (IEC) on all matters of electrotechnical standardization.

International Standards are drafted in accordance with the rules given in the ISO/IEC Directives, Part 2.

The main task of technical committees is to prepare International Standards. Draft International Standards adopted by the technical committees are circulated to the member bodies for voting. Publication as an International Standard requires approval by at least 75 % of the member bodies casting a vote.

Attention is drawn to the possibility that some of the elements of this document may be the subject of patent rights. ISO shall not be held responsible for identifying any or all such patent rights.

ISO 3303-2 was prepared by Technical Committee ISO/TC 45, *Rubber and rubber products*, Subcommittee SC 4, *Products other than hoses*.

Together with Part 1, it cancels and replaces ISO 3303:1990, which has been split into two parts and technically revised.

ISO 3303 consists of the following parts, under the general title *Rubber- or plastic-coated fabrics — Determination of bursting strength*:

- *Part 1: Steel-ball method*
- *Part 2: Hydraulic method*

## Introduction

The bursting strength of coated fabrics is often used as a measure of the multidirectional modulus of the material, as opposed to tensile properties which only provide guidance to the coated-fabric strength in one plane. In addition, bursting strength is more appropriate for testing materials prone to necking, such as coated fabrics with knitted substrates.

The method described in this part of ISO 3303, which employs an elastic diaphragm, is the more common method used in burst testing and is more suitable for the testing of lighter and medium-weight coated fabrics. Two aperture sizes are specified to allow the use of commercially available instruments, although results from the different machines might not be comparable





# Rubber- or plastics-coated fabrics — Determination of bursting strength —

## Part 2: Hydraulic method

### 1 Scope

This part of ISO 3303 specifies a method for the determination of the bursting strength of rubber- or plastics-coated fabrics, using one of two types of diaphragm bursting tester, designated type A and B, both operated by hydraulic pressure. The type A test machine is applicable to materials having bursting strengths ranging from 350 kPa to 5 500 kPa and the type B test machine is applicable to materials of bursting strengths ranging from 70 kPa to 1 400 kPa.

### 2 Normative references

The following referenced documents are indispensable for the application of this document. For dated references, only the edition cited applies. For undated references, the latest edition of the referenced document (including any amendments) applies.

ISO 2231, *Rubber- or plastics-coated fabrics — Standard atmospheres for conditioning and testing*

### 3 Principle

A test piece is securely clamped around its edges between an upper and lower clamp. A diaphragm fitted beneath the lower clamp is gradually stretched into a dome by forcing fluid at a constant rate into a chamber under the diaphragm, thus causing it to make contact with, and apply pressure to, the test piece. The pressure of the fluid and the height of the dome at failure of the test piece are recorded.

### 4 Apparatus

**4.1 Test machine**<sup>1)</sup>, of type A (see 4.1.1) or type B (see 4.1.2). In the case of materials for which the bursting-strength specification allows either type of test machine to be used, it is recommended that the customer and supplier mutually agree upon the test machine to be employed, as the test result from one type of test machine is not necessarily comparable with that from the other type.

**4.1.1 Type A test machine** (see Figure 1), measurement range between 350 kPa and 5 500 kPa, comprising the elements specified in 4.1.1.1 to 4.1.1.3.

**4.1.1.1 Clamping system**, for clamping the test piece firmly and with uniform loading between two plane, parallel, annular surfaces which are smooth (but not polished) and include grooves as shown in Figure 1, which also specifies the dimensions of the clamping system. One clamping plate is held in a swivel joint or similar device so as to ensure that the clamping pressure is distributed evenly. Under the load used for testing, the circular openings in the two clamping faces shall be concentric to within 0,25 mm and the clamping surfaces shall be flat and parallel.

**4.1.1.2 Diaphragm**, circular in shape, made of natural or synthetic rubber clamped securely, before the test begins, with its upper surface recessed about 5,5 mm relative to the upper surface of the lower clamp. The

1) Test machines of this type are often called Mullen burst testers. Such a tester is described in detail in ISO 2759.

material and construction of the diaphragm shall be such that the pressure required to cause the diaphragm to bulge beyond the upper surface of the lower clamp is as follows:

- bulge height 10 mm ± 0,2 mm, pressure range: 170 kPa to 220 kPa;
- bulge height 18 mm ± 0,2 mm, pressure range: 250 kPa to 350 kPa.

Diaphragms in use shall be regularly checked and changed should the bulge-height requirement be no longer met.

**4.1.1.3 Hydraulic system**, to apply an increasing hydraulic pressure to the inside of the diaphragm until the test piece bursts. The pressure shall be generated by a motor-driven piston forcing a suitable liquid (e.g. pure glycerol, low-viscosity silicone oil or ethylene glycol containing corrosion inhibitor) which is compatible with the diaphragm material against the inner surface of the diaphragm. The hydraulic system and the fluid used shall be free from air bubbles. The pumping rate shall be 170 ml/min ± 20 ml/min.

Dimensions in millimetres

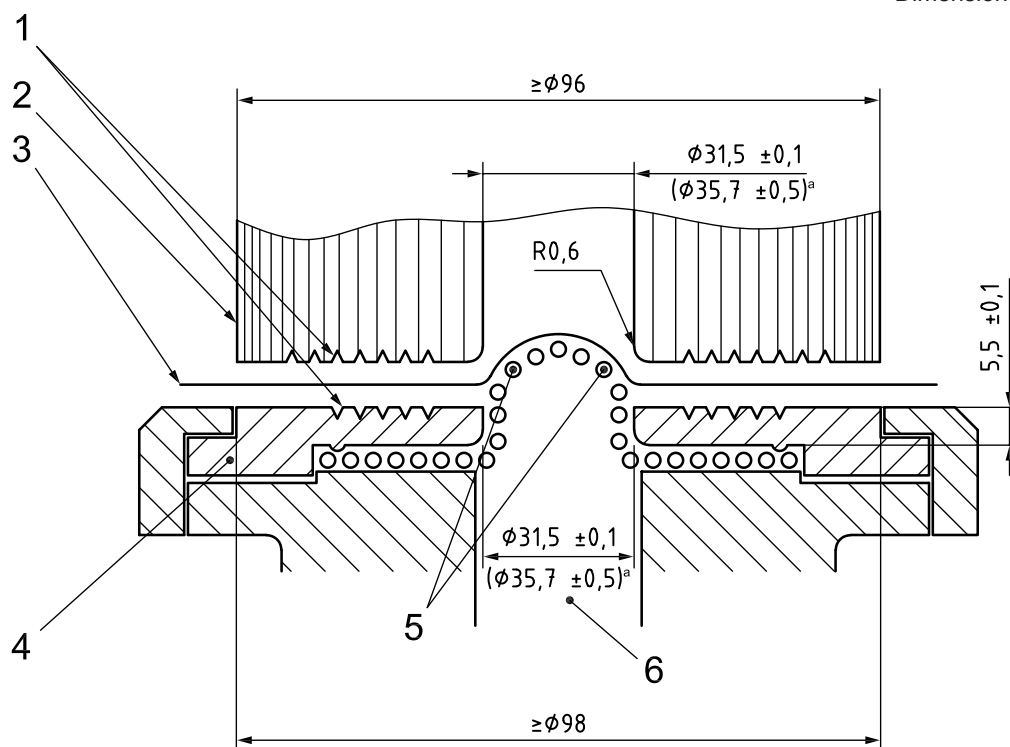

**Key**

- 1 continuous-spiral 60° V-groove or series of concentric 60° V-grooves
- 2 upper clamp
- 3 test piece
- 4 lower clamp
- 5 rubber diaphragm
- 6 pressure chamber

<sup>a</sup> In EN 12332-2, the diameter of the cylindrical bore through the upper and lower clamps is 35,7 mm, giving a clamped area of 10 cm<sup>2</sup>.

**Figure 1 — Type A test machine**

**4.1.2 Type B test machine** (see Figure 2), measurement range between 70 kPa and 1 400 kPa, comprising the elements specified in 4.1.2.1 to 4.1.2.3.

**4.1.2.1 Clamping system**, for clamping the test piece firmly and uniformly between two annular, plane, parallel surfaces which shall be smooth (but not polished) and grooved as described in Figure 2, which also gives the dimensions of the clamping system. One clamping plate shall be held in a swivel joint or similar device so as to ensure that the clamping pressure is distributed evenly. Under the load used for testing, the circular openings in the two clamping faces shall be concentric to within 0,25 mm and the clamping surfaces shall be flat and parallel.

**4.1.2.2 Diaphragm**, circular in shape, made of natural or synthetic rubber and  $0,86 \text{ mm} \pm 0,06 \text{ mm}$  thick, clamped securely, before the test begins, with its upper surface recessed about 3,5 mm relative to the upper surface of the lower clamp. The material and construction of the diaphragm shall be such that the pressure required to cause the diaphragm to bulge  $9,0 \text{ mm} \pm 0,2 \text{ mm}$  beyond the upper surface of the lower clamp is  $30 \text{ kPa} \pm 5 \text{ kPa}$ .

Diaphragms in use shall be regularly checked and changed should the bulge-height requirement be no longer met.

Dimensions in millimetres

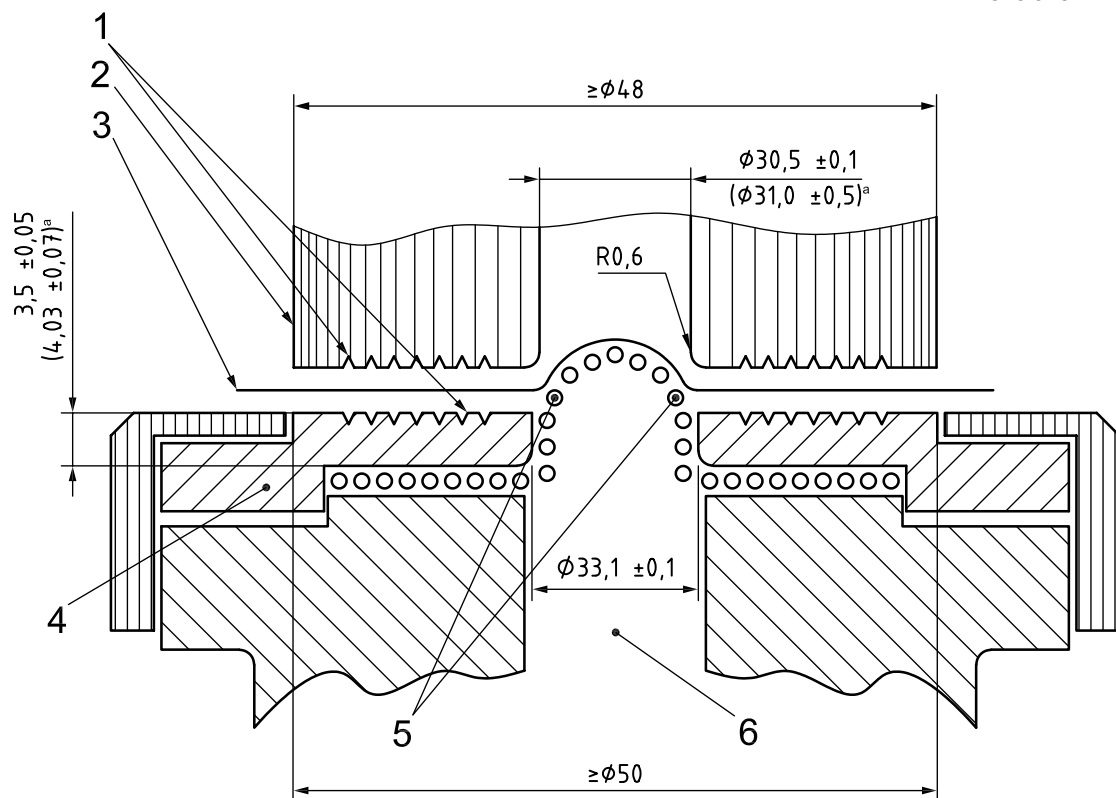

**Key**

- 1 continuous-spiral 60° V-groove or series of concentric 60° V-grooves
- 2 upper clamp
- 3 test piece
- 4 lower clamp
- 5 rubber diaphragm
- 6 pressure chamber

<sup>a</sup> The dimensions given in brackets are those of alternative test machines available commercially (see the introduction, second paragraph).

**Figure 2 — Type B test machine**

**4.1.2.3 Hydraulic system**, to apply an increasing hydraulic pressure to the inside of the diaphragm until the test piece bursts. The pressure shall be generated by a motor-driven piston forcing a suitable liquid (e.g. pure glycerol, low-viscosity silicone oil or ethylene glycol containing corrosion inhibitor) which is compatible with the diaphragm material against the inner surface of the diaphragm. The hydraulic system and the fluid used shall be free from air bubbles. The pumping rate shall be  $95 \text{ ml/min} \pm 5 \text{ ml/min}$ .

**4.2 Pressure-measuring system to measure bursting strength**, giving a rate of response to the rising hydraulic pressure which is such that the indicated maximum pressure is within  $\pm 3 \%$  of the true peak pressure.

## 5 Calibration

Calibration shall be carried out in accordance with the test machine manufacturer's manual before initial use and subsequently at sufficiently frequent intervals to maintain the specified accuracy.

## 6 Sampling

The sample shall be taken so that it is as representative as possible of the whole consignment.

## 7 Preparation of test pieces

**7.1** Take five test pieces across the usable width of the sample (see the note), at least 1 m from the extremity of the sample, and of sufficient size so that each test piece can be clamped firmly in the clamping system of the test machine. The smaller dimension of each test piece shall be at least 12 mm greater than the outside diameter of the clamping surfaces. Alternatively, the sample may be tested at the requisite locations across its width, avoiding areas that have already been used for a test by at least 20 mm.

**NOTE** The usable width is defined in ISO 2286-1 as that width, excluding the selvedge, which is consistent in its properties, uniformly finished, and free of unacceptable flaws.

**7.2** The face of the coated fabric to be tested shall be defined and agreed between the interested parties. The results might not be the same if the opposite face is tested.

## 8 Time-interval between manufacture and testing

**8.1** For all test purposes, the minimum time between manufacture and testing shall be 16 h.

**8.2** For non-product tests, the maximum time between manufacture and testing shall be four weeks and, for evaluations intended to be comparable, the tests, as far as possible, shall be carried out after the same time-interval.

**8.3** For products, whenever possible, the time between manufacture and testing shall not exceed three months. In other cases, tests shall be made within two months of the date of receipt by the customer.

## 9 Conditioning of test pieces

Condition the test pieces in one of the standard atmospheres for testing as defined in ISO 2231.

When it is required to determine the properties of wet material, immerse the test pieces for 24 h in distilled water containing 1 % of ethanol at the chosen standard temperature. Immediately after removal from the water, blot the test piece between two sheets of absorbent paper and test at once.

## 10 Procedure

**10.1** Increase the pressure on the rubber diaphragm by introducing liquid into the pressure chamber until the test piece bursts. Note the maximum pressure as indicated by the pointer of the pressure-measuring system, as well as the maximum distension of the diaphragm, and return the pointer to zero. Record, in addition, the type of burst obtained (i.e. cross or slit).

**10.2** Repeat this procedure for each test piece, ignoring any burst which occurs at or near the edge of the clamp and repeating, in such cases, the test on another test piece.

**10.3** Calculate the mean of the five results obtained for the bursting pressure and then apply the diaphragm correction factor determined as described in 10.4.

**10.4** With the same rate of liquid flow as that employed in the test, distend the diaphragm, without the presence of the test piece, but with the upper clamp in position, and note the pressure required to distend it by an amount equal to the average distension of the test piece at burst. This pressure is the “diaphragm correction factor” and is the value by which the mean bursting pressure shall be reduced.

**10.5** Report the corrected mean bursting pressure as the bursting strength.

## 11 Test report

The test report shall indicate the following particulars:

- a) a reference to this part of ISO 3303;
- b) all details necessary for the identification of the sample;
- c) the type of test machine used (A or B);
- d) the conditioning method, atmosphere and time of exposure or a statement to the effect that the test pieces were conditioned in the wet state;
- e) the conditions under which the test was conducted;
- f) each bursting pressure, expressed in kilopascals, the type of burst and the distension, in millimetres;
- g) the corrected mean bursting pressure;
- h) the date of the test.

## Bibliography

- [1] ISO 2286-1, *Rubber- or plastics-coated fabrics — Determination of roll characteristics — Part 1: Methods for determination of length, width and net mass*
- [2] ISO 2758, *Paper — Determination of bursting strength*
- [3] ISO 2759, *Board — Determination of bursting strength*
- [4] EN 12332-2, *Rubber- or plastics-coated fabrics — Determination of bursting strength — Part 2: Hydraulic method*



---

---

**ICS 59.080.40**

Price based on 6 pages





# British Standards Institution (BSI)

BSI is the national body responsible for preparing British Standards and other standards-related publications, information and services.

BSI is incorporated by Royal Charter. British Standards and other standardization products are published by BSI Standards Limited.

## About us

We bring together business, industry, government, consumers, innovators and others to shape their combined experience and expertise into standards-based solutions.

The knowledge embodied in our standards has been carefully assembled in a dependable format and refined through our open consultation process. Organizations of all sizes and across all sectors choose standards to help them achieve their goals.

## Information on standards

We can provide you with the knowledge that your organization needs to succeed. Find out more about British Standards by visiting our website at [bsigroup.com/standards](http://bsigroup.com/standards) or contacting our Customer Services team or Knowledge Centre.

## Buying standards

You can buy and download PDF versions of BSI publications, including British and adopted European and international standards, through our website at [bsigroup.com/shop](http://bsigroup.com/shop), where hard copies can also be purchased.

If you need international and foreign standards from other Standards Development Organizations, hard copies can be ordered from our Customer Services team.

## Subscriptions

Our range of subscription services are designed to make using standards easier for you. For further information on our subscription products go to [bsigroup.com/subscriptions](http://bsigroup.com/subscriptions).

With **British Standards Online (BSOL)** you'll have instant access to over 55,000 British and adopted European and international standards from your desktop. It's available 24/7 and is refreshed daily so you'll always be up to date.

You can keep in touch with standards developments and receive substantial discounts on the purchase price of standards, both in single copy and subscription format, by becoming a **BSI Subscribing Member**.

**PLUS** is an updating service exclusive to BSI Subscribing Members. You will automatically receive the latest hard copy of your standards when they're revised or replaced.

To find out more about becoming a BSI Subscribing Member and the benefits of membership, please visit [bsigroup.com/shop](http://bsigroup.com/shop).

With a **Multi-User Network Licence (MUNL)** you are able to host standards publications on your intranet. Licences can cover as few or as many users as you wish. With updates supplied as soon as they're available, you can be sure your documentation is current. For further information, email [bsmusales@bsigroup.com](mailto:bsmusales@bsigroup.com).

## BSI Group Headquarters

389 Chiswick High Road London W4 4AL UK

## Revisions

Our British Standards and other publications are updated by amendment or revision.

We continually improve the quality of our products and services to benefit your business. If you find an inaccuracy or ambiguity within a British Standard or other BSI publication please inform the Knowledge Centre.

## Copyright

All the data, software and documentation set out in all British Standards and other BSI publications are the property of and copyrighted by BSI, or some person or entity that owns copyright in the information used (such as the international standardization bodies) and has formally licensed such information to BSI for commercial publication and use. Except as permitted under the Copyright, Designs and Patents Act 1988 no extract may be reproduced, stored in a retrieval system or transmitted in any form or by any means – electronic, photocopying, recording or otherwise – without prior written permission from BSI. Details and advice can be obtained from the Copyright & Licensing Department.

## Useful Contacts:

### Customer Services

**Tel:** +44 845 086 9001

**Email (orders):** [orders@bsigroup.com](mailto:orders@bsigroup.com)

**Email (enquiries):** [cservices@bsigroup.com](mailto:cservices@bsigroup.com)

### Subscriptions

**Tel:** +44 845 086 9001

**Email:** [subscriptions@bsigroup.com](mailto:subscriptions@bsigroup.com)

### Knowledge Centre

**Tel:** +44 20 8996 7004

**Email:** [knowledgecentre@bsigroup.com](mailto:knowledgecentre@bsigroup.com)

### Copyright & Licensing

**Tel:** +44 20 8996 7070

**Email:** [copyright@bsigroup.com](mailto:copyright@bsigroup.com)



...making excellence a habit.™